

TECHNICAL MANUAL
VOLUME 3 OF 3
PART 1 OF 4
MAINTENANCE
ORGANIZATIONAL LEVEL
2 ½-TON, 6X6, M44A1 AND M44A2 SERIES TRUCKS
(MULTIFUEL)

TRUCK, CARGO: M35A1,
M35A2, M35A2C, M36A2; TRUCK,
TANK, FUEL: M49A1C, M49A2C; TRUCK, TANK,
WATER: M50A1, M50A2, M50A3; TRUCK, VAN,
SHOP: M109A2, M109A3; TRUCK, REPAIR SHOP:
M185A2, M185A3; TRUCK, TRACTOR: M275A1,
M275A2; TRUCK, DUMP: M342A2; TRUCK,
MAINTENANCE, PIPELINE CONSTRUCTION:
M756A2; TRUCK, MAINTENANCE,
EARTH BORING AND POLESETTING: M764

NOTE:
THE STYLE OF THIS TM IS
EXPERIMENTAL. IT IS BEING TRIED
BY THE ARMY ONLY ON
A LIMITED BASIS

Chapter 1
General Maintenance Information

Chapter 2
Engine System

Chapter 3
Clutch System

Chapter 4
Fuel System

Chapter 5
Exhaust System

Chapter 6
Cooling System

Chapter 7
Electrical System

Chapter 8
Transmission System

Chapter 9
Transmission Transfer System

Chapter 10
Propeller Shafts

Chapter 11
Front Axle

Chapter 12
Rear Axle

DEPARTMENTS OF THE ARMY AND THE AIR FORCE

MAY 1981

TECHNICAL MANUAL

NO. 9-2320 -209-20-3-1

TM 9-2320-209-20-3-1

C1

TECHNICAL ORDER

NO. 36A12-1B-1092-1-3

CHANGE

No. 1

HEADQUARTERS
DEPARTMENT OF THE ARMY
WASHINGTON D.C., 16 April 1990

T E C H N I C A L M A N U A L
V O L U M E 3 O F 3
P A R T 1 O F 4
M A I N T E N A N C E
O R G A N I Z A T I O N A L L E V E L
2-½ TON, 6X6, M44A1 AND M44A2 SERIES TRUCKS
(M U L T I F U E L)

TRUCK, CARGO: M35A1
M35A2, M35A2C, M36A2C; TRUCK,
M35A2, M35A2C, M36A2C; TRUCK,
TANK, FUEL: M49A1C; TRUCK, TANK,
WATER, M50A1, M5012, M50A3; TRUCK, VAN,
SHOP: M109A2, M109A3; TRUCK, REPAIR, SHOP:
M185A2, M185A3; TRUCK, TRACTOR: M275A1,
M275A2; TRUCK, DUMP: M342A2; TRUCK,
MAINTENANCE, PIPELINE CONSTRUCTION:
M756A2; TRUCK, MAINTENANCE,
EARTH BORING AND POLSETTING: M764

TM 9-2320-209-20-3-1, 27 May 1981, is changed as follows:

1. Remove old pages and insert new pages as indicated below.
2. New or changed information is indicated by a vertical bar in the margin of the page.

Remove Page

iii and iv
None

Insert Page

iii and iv
4-50.1 through 4-50.6

3. File this changed sheet in front of this publication for reference purposes.

By Order of the Secretary of the Army:

Official: CARL E. VUONO
General , United States Army
Chief of Staff

WILLIAM J. MEEHAN II
Brigadier General, United States Army
The Adjutant General

By Order of the Secretary of the Air Force:

LARRY D. WELCH
General, United States Air Force
Chief of Staff

CHARLES C. McDONALD
General , United States Air Force
Commander, Air Force Logistics Command

DISTRIBUTION:

To be distributed in accordance with DA form 12-38 (Block Nos. 0201, 0202), Operator and Unit maintenance requirements for Truck, Multifuel, 2½-ton, 6x6, M44A1 and M44A2 series.

WARNING

EXHAUST GASES CAN BE DEADLY

Exposure to exhaust gases produces symptoms of headache, dizziness, loss of muscular control, apparent drowsiness, and coma. Permanent brain damage or death can result from severe exposure.

Carbon monoxide occurs in the exhaust fumes of fuel burning heaters and internal combustion engines, and becomes dangerously concentrated under conditions of inadequate ventilation. The following precautions must be observed to insure the safety of personnel whenever fuel burning heater(s) or engine of any vehicle is operated for maintenance purposes or tactical use.

Do not operate heater or engine of vehicle in an enclosed area unless it is adequately ventilated.

Do not idle engine for long periods without maintaining adequate ventilation in personnel compartments.

Be alert at all times during vehicle operation for exhaust odors and exposure symptoms. If either are present, immediately ventilate personnel compartments. If symptoms persist, remove affected personnel from vehicle and treat as follows: expose to fresh air; keep warm; do not permit physical exercise; if necessary, administer artificial respiration.

If exposed, seek prompt medical attention for possible delayed onset of acute lung congestion. Administer oxygen if available.

The best defense against exhaust gas poisoning is adequate ventilation.

WARNING

Serious or fatal injury to personnel may result if the following instructions are not complied with.

When removing or replacing engine mounts do not put fingers between front mounting support and bracket. Jack could slip, causing severe injury to personnel.

Smoking, flames, sparks and glowing or hot objects are not allowed within 50 feet of work area during maintenance of fuel system components. Fuel can explode, causing injury to personnel and damage to equipment.

Dry cleaning solvent is flammable. Do not use near an open flame. Keep a fire extinguisher nearby when solvent is used. Use only in well-ventilated places. Failure to do this may result in injury to personnel and damage to equipment.

Make sure that fuel pump replacement fuse is 2 amperes. Higher ampere fuse could cause fuel to explode if pump overheats.

Voltage output of manifold heater ignition unit can cause a dangerous electrical shock. Do not touch any uninsulated or live connections until you make sure manifold heater switch is in OFF position. Read warning notice on ignition unit.

Do not work on hot exhaust systems. Personnel can be badly burned.

Exhaust pipe flange is slotted. Aline flange correctly so exhaust does not leak. Leaking exhaust can cause serious injury or death to personnel.

WARNING - Cont

Use rubber gloves when working with cleaning compound. Do not spill cleaning compound on skin, clothing or truck. Cleaning compound contains strong acid and will cause serious burns to personnel and damage to equipment.

Do not take off radiator filler cap before pressure has been let out. Pressure will blow out scalding fluid and vapor. Personnel can be badly burned.

Be very careful when using jumper wires. Shorting wire to ground can burn connector pins or wiring and cause injury to personnel and damage to equipment.

Be careful when lifting alternator. It is heavy and could injure personnel or damage equipment if dropped.

Retaining springs (1) may snap out and cause injury. Cover spring with free hand when prying them loose.

Do not get electrolyte on personnel or equipment. Battery electrolyte will burn wood, clothing, and skin. Wash spills immediately with flowing water. Use paste solution of sodium bicarbonate and water to apply to affected area.

Personnel may be badly burned, and equipment may be damaged.

Wear rubber gloves and eye shields while working with electrolyte to avoid serious injury from battery acid.

Be very careful not to short positive and negative battery posts against battery box retainer. This could cause retainer to melt and battery to explode. Explosion could cause injury to personnel.

Do not let tools touch positive terminal on batteries and truck or there will be a direct short and arcing and tool will heat. This could cause equipment damage and injury to personnel.

When compressing spring on reverse shift rod, use vise or clamp to hold spring compressed. Be careful spring does not slip out of vise or clamp, causing injury to personnel.

Never work under truck with only one jack supporting truck. Truck may slip off jack. Weight of truck must be supported by trestles or support stands, with capacity for weight of truck.

Always jack up one wheel of the axle driven by propeller shaft being removed. This is to keep personnel from being hurt by windup of shaft.

Keep hands away from front wheels when jacking truck. Wheels may turn as they clear the ground and cause injury to personnel.

* **TM 9-2320-209-20-3-1**
T.O. 36A12-1B-1092-1-3
DEPARTMENTS OF THE ARMY
AND
THE AIR FORCE
Washington, D. C., 27 May 1981

TECHNICAL MANUAL
NO. 9-2320-209-20-3-1
TECHNICAL ORDER
NO. 36A12-1B-1092-1-3

TECHNICAL MANUAL
VOLUME 3 OF 3
PART 1 OF 4
MAINTENANCE
ORGANIZATIONAL LEVEL
2½-TON, 6X6, M44A1 AND M4A2 SERIES TRUCKS
(MULTIFUEL)

Model		NSN without Winch	NSN with Winch
Truck, Cargo	M35A1	2320-00-542-5633	2320-00-542-5634
	M35A2	2320-00-077-1616	2320-00-077-1617
	M35A2C	2320-00-926-0873	2320-00-926-0875
	M36A2	2320-00-077-1618	2320-00-077-1619
Truck, Tank, Fuel	M49A1C	2320-00-440-3349	2320-00-440-3346
	M49A2C	2320-00-077-1631	2320-00-077-1632
Truck, Tank, Water	M50A1	2320-00-440-8307	2320-00-440-8305
	M50A2	2320-00-077-1633	2320-00-077-1634
	M50A3	2320-00-937-4036	2320-00-937-5264
Truck, Van, Shop	M109A2	2320-00-440-8313	2320-00-440-8308
	M109A3	2320-00-077-1636	2320-00-077-1637
Truck, Repair Shop	M185A2	4940-00-987-8799	
	M185A3	4940-00-077-1638	4940-00-077-1639
Truck, Tractor	M275A1	2320-00-446-2479	
	M275A2	2320-00-077-1640	2320-00-077-1641
Truck, Dump	M342A2	2320-00-077-1643	2320-00-077-1644
Truck, Maintenance, Pipeline Construction	M756A2		2320-00-904-3277
Truck, Maintenance, Earth Boring and Polesetting	M764		2320-00-937-5980

*This manual, together with TM 9-2320-209-20-1, 27 May 1981; TM 9-2320-20-2-1, 27 May 1981; TM 9-2320-209-20-2-2, 27 May 1981; TM 9-2320-209-20-3-2, 27 May 1981; TM 9-2320-209-20-3-3, 27 May 1981; and TM 9-2320-209-20-3-4, 27 May 1981, supersedes TM 9-2320-209-20-1, 31 August 1978.

REPORTING OF ERRORS AND RECOMMENDING IMPROVEMENTS

You can help improve this manual. If you find any mistake or if you know of a way to improve the procedure, please let us know. Mail your letter, DA Form 2028 (Recommended Changes to Publication and Blank Forms) , or DA Form 2028-2 located in the back of this manual direct to: Commander, U.S. Army Tank Automotive Materiel Readiness Command, ATTN: DRSTA-MB , Warren, Michigan 48090. A reply will be furnished to you.

TABLE OF CONTENTS

	Paragraph	Page
CHAPTER 1. GENERAL MAINTENANCE INFORMATION		
Scope	1-1	1-1
General Maintenance	1-2	1-1
Cleaning	1-3	1-1
Painting	1-4	1-2
Air System Leakage Test....	1-5	1-2
Torque Values	1-6	1-2
Special Tools and Equipment	1-7	1-2
Common Tools	1-8	1-2
Safety Inspection and Testing of Lifting Device . . .	1-9	1-2
Forms and Records	1-10	1-2
Equipment Improvement Report and Maintenance Digest (EIR MD) and Equipment Improvement Report and Maintenance Summary (EIR MS)	1-11	1-2
Reporting Improvement Recommendations	1-12	1-5
Metric System	1-13	1-5
Destruction to Prevent Enemy Use	1-14	1-5
Vehicle Description	1-15	1-5
Tabulated Data	1-16	1-5
Service Upon. Receipt of Materiel	1-17	1-10
Tools and Equipment	1-18	1-11
Maintenance Repair Parts	1-19	1-11
General Lubrication Instructions	1-20	1-11
Administrative Storage	1-21	1-11
CHAPTER 2. ENGINE SYSTEM GROUP MAINTENANCE		
Section I . Scope		2-1
Equipment Items Covered	2-1	2-1
Equipment Items Not Covered	2-2	2-1
Section II . Engine Assembly		2-1
Front Engine Mounts Removal and Replacement . . .	2-3	2-1
Preliminary Procedure	2-3a	2-1
Identification of Engine Mounts	2-3b	2-2
Removal (Basic Type)	2-3c	2-3
Replacement (Basic Type)	2-3d	2-5
Removal (Revised Type)	2-3e	2-6
Replacement (Revised Type)	2-3f	2-8

TABLE OF CONTENTS-CONT

		Paragraph	Page
	Rear Engine Mounts Removal and Replacement	2-4	2-10
	Preliminary Procedure	2-4a	2-10
	Removal	2-4b	2-10
	Replacement	2-4C	2-12
Section III.	Engine Lubrication System		2-13
	Oil Filter Element Removal and Replacement	2-5	2-13
	Preliminary Procedure	2-5a	2-13
	Removal	2-5b	2-13
	Replacement	2-5C	2-16
	Crankcase Breather Tube Removal and Replacement	2-6	2-19
	Preliminary Procedure	2-6a	2-19
	Removal	2-6b	2-19
	Replacement	2-6C	2-24
CHAPTER 3.	CLUTCH SYSTEM GROUP MAINTENANCE		
Section 1.	Scope		3-1
	Equipment Items Covered	3-1	3-1
	Equipment Items Not Covered	3-2	3-1
Section II.	Clutch Linkage Assembly		3-1
	Clutch Control and Linkage Removal, Repair, Replacement, and Adjustment	3-3	3-1
	Preliminary Procedures	3-3a	3-1
	Removal	3-3b	3-2
	Repair	3-3C	3-7
	Replacement	3-3d	3-7
	Adjustment	3-3e	3-15
CHAPTER 4.	FUEL SYSTEM GROUP MAINTENANCE		
Section 1.	Scope		4-1
	Equipment Items Covered	4-1	4-1
	Equipment Items Not Covered	4-2	4-1
Section 11.	Air Cleaner		4-1
	Intake Air Cleaner Removal, Repair, and Replacement	4-3	4-1
	Preliminary Procedure	4-3a	4-1
	Removal	4-3b	4-2
	Repair	4-3C	4-4
	Replacement	4-3d	4-4
	Air Cleaner Indicator Removal and Replacement	4-4	4-6
	Removal	4-4a	4-6
	Replacement	4-4b	4-7
Section III.	Fuel Tanks and Fuel Lines		4-8
	Fuel Lines and Fittings Removal and Replacement	4-5	4-8
	Removal	4-5a	4-9
	Replacement	4-5b	4-19

TABLE OF CONTENTS-CONT

		Paragraph	Page
	Fuel Tank Removal and Replacement (All Trucks Except Trucks M275A1 and M275A2)	4-6	4-29
	Preliminary Procedures	4-6a	4-29
	Removal	4-6b	4-29
	Replacement	4-6c	4-31
	Fuel Tank Removal and Replacement (Trucks M275A1 and M275A2)	4-7	4-33
	Preliminary Procedures	4-7a	4-33
	Removal	4-7b	4-33
	Replacement	4-7c	4-39
	Fuel Pump (In-Tank) Removal and Replacement	4-8	4-46
	Preliminary Procedures	4-8a	4-46
	Removal	4-8b	4-46
	Replacement	4-8c	4-48
	Fuel Pump (In-Tank) Bracket and Pump Assemblies	4-8.1	4-50.1
	Preliminary Procedures	4-8.1a	4-50.1
	Removal	4-8.1b	4-50.3
	Replacement	4-8.1c	4-50.5
	Fuel Pump (In-Tank) Fuse Removal and Replacement	4-9	4-51
	Removal	4-9a	4-51
	Replacement	4-9b	4-53
Section IV.	Fuel Filter		4-55
	Fuel Filter Assemblies Removal, Replacement, and Air Bleeding	4-10	4-55
	Preliminary Procedures	4-10a	4-55
	Removal of Primary Fuel Filter Assembly	4-10b	4-55
	Removal of Secondary and Final Fuel Filter Assemblies	4-10c	4-57
	Replacement of Primary Fuel Filter	4-10d	4-58
	Replacement of Secondary and Final Fuel Filter Assemblies	4-10e	4-60
	Air Bleeding of Low Pressure Fuel System	4-10f	4-61
	Fuel Filters Repair	4-11	4-63
	Preliminary Procedures	4-11a	4-63
	Disassembly of Primary Fuel Filter	4-11b	4-63
	Disassembly of Secondary and Final Fuel Filters	4-11c	4-65
	Cleaning, Inspection, and Repair	4-11d	4-67
	Assembly of Primary Fuel Filter	4-11e	4-67
	Assembly of Secondary and Final Fuel Filters	4-11f	4-69
Section V.	Engine Starting Aids		4-71
	Manifold Heater (Top-Mounted, Uncovered) Nozzle and Valve Assembly, Removal and Replacement (Trucks with Engines LDS 427-2 and LDS 465-1)	4-12	4-71
	Preliminary Procedure	4-12a	4-71
	Removal	4-12b	4-71
	Replacement	4-12c	4-72

TABLE OF CONTENTS-CONT

	Paragraph	Page
Manifold Heater (Top-Mounted, Uncovered)		
Ignition Unit Removal and Replacement	4-13	4-73
Preliminary Procedures	4-13a	4-73
Removal	4-13b	4-73
Replacement	4-13c	4-74
Manifold Heater (Top-Mounted, Uncovered)		
Spark Plug Removal and Replacement		
(Trucks with Engines LDS 427-2 and		
LDS 465-1)	4-14	4-75
Preliminary Procedure	4-14a	4-75
Removal	4-14b	4-75
Replacement	4-14c	4-76
Manifold Heater (Side-Mounted) Fuel		
Filter Removal and Replacement	4-15	4-77
Preliminary Procedure	4-15a	4-77
Removal	4-15b	4-78
Replacement	4-15c	4-82
Manifold Heater (Side-Mounted) Spark Plug		
and Nozzle Removal and Replacement	4-16	4-86
Preliminary Procedures	4-16a	4-86
Removal	4-16b	4-86
Replacement	4-16c	4-87
Engine Manifold Heater Removal and		
Replacement (Trucks with Engines		
LDS 427-2 and LDS 465-1)	4-17	4-88
Preliminary Procedure	4-17a	4-88
Removal	4-17b	4-89
Replacement	4-17c	4-91
Manifold Heater Fuel Pump Removal and		
Replacement (Trucks with Engines		
LDS 427-2 and LDS 465-1)	4-18	4-94
Preliminary Procedure	4-18a	4-94
Removal	4-18b	4-94
Replacement	4-18c	4-96
Manifold Heater Electric Fuel Supply Pump		
and Fuel Filter Removal and Replacement	4-19	4-98
Preliminary Procedures	4-19a	4-98
Removal	4-19b	4-98
Replacement	4-19c	4-100
Engine Manifold Heater Pump Lines and		
Fittings Removal and Replacement (Trucks		
with Engines LDS 427-2 and LDS 465-1)	4-20	4-102
Preliminary Procedures	4-20a	4-102
Removal	4-20b	4-102
Replacement	4-20c	4-111
Manifold Heater Nozzle and Valve Assembly		
Removal and Replacement	4-21	4-121
Preliminary Procedure	4-21a	4-121
Removal	4-21b	4-121
Replacement	4-21c	4-122

TABLE OF CONTENTS-CONT

Paragraph Page

Manifold Heater Ignition Unit		
Removal and Replacement (Trucks with Engines LDS 427-2 and LDS 465-1)	4-22	4-123
Preliminary Procedure	4-22a	4-123
Removal	4-22b	4-123
Replacement	4-22C	4-125
Manifold Heater (Top-Mounted, Covered)		
Spark Plug Removal and Replacement	4-23	4-127
Preliminary Procedure	4-23a	4-127
Removal	4-23b	4-127
Replacement	4-23C	4-128
Manifold Heater (Top-Mounted, Covered)		
Fuel Filter Removal and Replacement	4-24	4-129
Preliminary Procedure	4-24a	4-129
Removal	4-24b	4-129
Replacement	4-24c	4-130
Intake Manifold (Top-Mounted, Covered)		
Flame Heater and Elbow Removal and Replacement (Trucks with Engines LD 465-1, LD 465-1C, and LDT 465-1C)	4-25	4-131
Preliminary Procedures	4-25a	4-131
Removal	4-25b	4-132
Replacement	4-25C	4-138
Manifold Flame Heater (Top-Mounted, Covered) Fuel Pump and Ignition Unit		
Removal and Replacement (Trucks with Engines LD 465-1, LD 465-1C and LDT 465-1C)	4-26	4-143
Preliminary Procedures	4-26a	4-143
Removal	4-26b	4-144
Replacement	4-26c	4-147
Manifold Heater (Top-Mounted, Covered) Ignition Coil and Fuel Pump Removal and Replacement (Trucks with Engine LD 65-1C)	4-27	4-150
Preliminary Procedures	4-27a	4-150
Removal	4-27b	4-151
Replacement	4-27C	4-154
Section VI. Accelerator, Throttle, and Engine Stop Controls		4-157
Throttle Control and Linkage Removal, Repair, Replacement and Adjustment.	4-28	4-157
Preliminary Procedure	4-28a	4-157
Removal	4-28b	4-157
Repair	4-28c	4-160
Replacement	4-28d	4-160
Adjustment	4-28e	4-163
Accelerator Controls and Linkages, Removal, Repair, Replacement, and Adjustment.	4-29	4-166
Preliminary Procedure	4-29a	4-166
Removal	4-29b	4-166

TABLE OF CONTENTS-CONT

		Paragraph	Page
	Repair	4-29C	4-169
	Replacement	4-29d	4-169
	Adjustment	4-29e	4-174
	Engine Stop Controls and Linkages		
	Removal, Repair, Replacement, and		
	Adjustment	4-30	4-175
	Preliminary Procedures	4-30a	4-175
	Removal	4-30b	4-175
	Repair	4-30C	4-177
	Replacement	4-30d	4-177
	Adjustment	4-30e	4-179
CHAPTER 5.	EXHAUST SYSTEM GROUP MAINTENANCE		
Section I.	Scope		5-1
	Equipment Items Covered	5-1	5-1
	Equipment Items Not Covered	5-2	5-1
Section II.	Exhaust Pipes and Mufflers		5-1
	Exhaust System (Horizontal) Removal and		
	Replacement (Trucks with Engine LD 465)	5-3	5-1
	Preliminary Procedure	5-3a	5-1
	Removal	5-3b	5-2
	Replacement	5-3C	5-10
	Exhaust System (Horizontal) Removal and		
	Replacement (Trucks M50A1, M50A2,		
	and M50A3)	5-4	5-17
	Preliminary Procedure	5-4a	5-17
	Removal	5-4b	5-18
	Replacement	5-4C	5-30
	Exhaust System (Horizontal) Removal and		
	Replacement (Trucks with Engine LD 427)	5-5	5-45
	Preliminary Procedures	5-5a	5-45
	Removal	5-5b	5-45
	Replacement	5-5C	5-50
	Exhaust System (Vertical Stack) Removal		
	and Replacement (Trucks with Engines		
	LD 465-1, LD 465-1C , and LDT 465-IC		
	Except Truck M50A2 and M50A3)	5-6	5-55
	Preliminary Procedure	5-6a	5-55
	Removal	5-6b	5-55
	Replacement	5-6C	5-64
	Exhaust System (Clean Air) Removal and		
	Replacement	5-7	5-76
	Preliminary Procedure	5-7a	5-76
	Removal	5-7b	5-76
	Replacement	5-7C	5-83
CHAPTER 6.	COOLING SYSTEM GROUP MAINTENANCE		
Section I.	Scope		6-1
	Equipment Items Covered	6-1	6-1
	Equipment Items Not Covered	6-2	6-1

TABLE OF CONTENTS-CONT

		Paragraph	Page
Section II.	Radiator Assembly		6-1
	Radiator Removal and Replacement	6-3	6-1
	Preliminary Procedures	6-3a	6-1
	Removal	6-3b	6-1
	Replacement	6-3C	6-8
	Radiator Stone Shield Removal and Replacement	6-4	6-16
	Preliminary Procedure	6-4a	6-16
	Removal	6-4b	6-16
	Replacement	6-4C	6-18
	Hoses and Clamps Removal and Replacement . . .	6-5	6-20
	Cooling System Hoses and Clamps	6-5a	6-20
	Turbocharger System Hoses and Clamps	6-5b	6-27
Section III.	Thermostat		6-31
	Thermostat Removal and Replacement	6-6	6-31
	Preliminary Procedures	6-6a	6-31
	Removal	6-6b	6-31
	Replacement	6-6C	6-34
Section IV.	Water Pump		6-39
	Water Pump Removal and Replacement	6-7	6-39
	Preliminary Procedures	6-7a	6-39
	Removal	6-7b	6-39
	Replacement	6-7C	6-40
Section V.	Fan Assembly and Related Parts		6-42
	Engine Cooling Fan Removal and Replacement . .	6-8	6-42
	Preliminary Procedures	6-8a	6-42
	Removal	6-8b	6-42
	Replacement	6-8C	6-43
	Fan Drive Belts Removal, Replacement, and Adjustment	6-9	6-44
	Preliminary Procedure	6-9a	6-44
	Removal	6-9b	6-44
	Replacement and Adjustment	6-9C	6-46
Section VI.	Cooling System Service		6-49
	Cooling System Service	6-10	6-49
	Preliminary Procedure	6-10a	6-49
	Draining	6-10b	6-50
	Cleaning	6-10C	6-51
	Flushing	6-10d	6-54
	Neutralization	6-10e	6-67
	Filling	6-10f	6-73
CHAPTER 7.	ELECTRICAL SYSTEM GROUP MAINTENANCE		
Section I.	Scope		7-1
	Equipment Items Covered	7-1	7-1
	Equipment Items Not Covered	7-2	7-1
Section II.	Charging System		7-1
	Generator and Pulley Removal and Replacement.	7-3	7-1
	Preliminary Procedures	7-3a	7-1
	Removal	7-3b	7-2

TABLE OF CONTENTS-CONT

		Paragraph	Page
	Replacement	7-3C	7-6
	Polarization	7-3d	7-11
	Alternator and Pulley Removal and Replacement	7-4	7-14
	Preliminary Procedures	7-4a	7-14
	Removal	7-4b	7-14
	Replacement	7-4C	7-20
	Generator Regulator Removal and Replacement	7-5	7-27
	Preliminary Procedures	7-5a	7-27
	Removal	7-5b	7-27
	Replacement	7-5C	7-28
Section III.	Starting System		7-29
	Starter Pedal and Linkage Assembly Removal, Repair, and Replacement	7-6	7-29
	Preliminary Procedures	7-6a	7-29
	Removal	7-6b	7-29
	Repair	7-6C	7-31
	Replacement	7-6d	7-31
	Magnetic Starter Switch Removal and Replacement	7-7	7-35
	Preliminary Procedures	7-7a	7-35
	Removal	7-7b	7-36
	Replacement	7-7C	7-38
	Starter Switch Removal, Replacement and Adjustment (Trucks with Pedal Starter)	7-8	7-41
	Preliminary Procedures	7-8a	7-41
	Removal	7-8b	7-41
	Replacement	7-8C	7-42
	Adjustment	7-8d	7-44
	Starter Button Removal and Replacement	7-9	7-46
	Preliminary Procedure	7-9a	7-46
	Removal	7-9b	7-46
	Replacement	7-9C	7-47
	Engine Starter Removal and Replacement (Trucks with Floor Pedal Starter Switch)	7-10	7-48
	Preliminary Procedures	7-10a	7-48
	Removal	7-10b	7-48
	Replacement	7-10C	7-51
	Engine Starter Removal and Replacement (Trucks with Pushbutton Starter Switch)	7-11	7-54
	Preliminary Procedures	7- 11a	7-54
	Removal	7-11b	7-54
	Replacement	7-11C	7-59
Section IV.	Instrument Panel Components		7-64
	Instrument Cluster Removal and Replacement	7-12	7-64
	Preliminary Procedure	7-12a	7-64
	Removal	7-12b	7-64
	Replacement	7-12c	7-69

TABLE OF CONTENTS-CONT

	Paragraph	Page
Instrument Cluster Components (Except Speedometer and Tachometer) Removal and Replacement	7-13	7-74
Preliminary Procedures	7-13a	7-74
Removal	7-13b	7-74
Replacement	7-13C	7-76
Light Switch Removal and Replacement	7-14	7-78
Preliminary Procedure	7-14a	7-78
Removal	7-14b	7-78
Replacement	7-14C	7-80
Accessory Switch Removal and Replacement . . .	7-15	7-82
Preliminary Procedure	7-15a	7-82
Removal	7-15b	7-82
Replacement	7-15C	7-84
Circuit Breaker Removal and Replacement	7-16	7-86
Preliminary Procedures	7-16a	7-86
Removal	7-16b	7-86
Replacement	7-16c	7-87
Section V. Lighting System		7-88
Front Service Headlight Assembly Removal and Replacement	7-17	7-88
Preliminary Procedure	7-17a	7-88
Removal	7-17b	7-88
Replacement	7-17C	7-89
Front Service Headlight Assembly Repair	7-18	7-90
Preliminary Procedures	7-18a	7-90
Disassembly	7-18b	7-90
Cleaning, Inspection, and Repair	7-18C	7-92
Assembly	7-18d	7-93
Front Service Headlight Assembly Adjustment . .	7-19	7-95
Front Service Sealed Beam Removal and Replacement	7-20	7-102
Removal	7-20a	7-102
Replacement	7-20b	7-103
Blackout Drive Light Assembly and Bracket Removal and Replacement (Trucks with Winch)	7-21	7-104
Preliminary Procedure	7-21a	7-104
Removal	7-21b	7-104
Replacement	7-21c	7-106
Blackout Drive Light Assembly and Bracket Removal and Replacement (Trucks Without Winch)	7-22	7-109
Preliminary Procedure	7-22a	7-109
Removal	7-22b	7-109
Replacement	7-22C	7-111
Blackout Drive Light Sealed Beam Unit Removal and Replacement	7-23	7-113
Removal	7-23a	7-113
Replacement	7-23b	7-115

TABLE OF CONTENTS-CONT

	Paragraph	Page
Blackout Drive Light Assembly Repair	7-24	7-117
Preliminary Procedures	7-24a	7-117
Cleaning, Inspection and Repair	7-24b	7-118
Taillight and Stoplight Assembly (Right Side Only) Removal and Replacement (Early Model Trucks with Turn Signals)	7-25	7-119
Preliminary Procedure	7-25a	7-119
Removal	7-25b	7-119
Replacement	7- 25c	7-120
Taillight and Stoplight Assembly (Right Side Only) Repair (Truck M756A2).	7-26	7-121
Preliminary Procedures	7-26a	7-121
Disassembly	7-26b	7-121
Cleaning, Inspection, and Repair	7-26c	7-122
Assembly	7-26d	7-123
Taillight and Stoplight Lamps (Right Side Only) Removal and Replacement	7-27	7-124
Removal	7-27a	7-124
Replacement	7-27b	7-124
Taillight and Stoplight Assembly (Left Side Only) Removal and Replacement	7-28	7-126
Removal	7-28a	7-126
Replacement	7-28b	7-127
Taillight and Stoplight Lamp (Left Side Only) Removal and Replacement	7-29	7-128
Removal	7-29a	7-128
Replacement	7-29b	7-129
Taillight and Stoplight Assembly (Left Side Only) Repair	7-30	7-130
Preliminary Procedures	7-30a	7-130
Disassembly	7-30b	7-130
Cleaning, Inspection, and Repair	7-30c	7-131
Assembly	7-30d	7-132
Blackout Stoplight Assembly (Right Side Only) Removal and Replacement (Early Model Trucks with Turn Signals)	7-31	7-133
Removal	7-31a	7-133
Replacement	7-31b	7-134
Blackout Stoplight Lamp (Right Side Only) Removal and Replacement (Early Model Trucks with Turn Signals)	7-32	7-135
Removal	7-32a	7-135"
Replacement	7-32b	7-136
Blackout Stoplight Assembly (Right Side Only) Repair	7-33	7-137
Preliminary Procedure	7-33a	7-137
Disassembly	7-33b	7-137
Repair	7-33c	7-138
Assembly	7-33d	7-138

TABLE OF CONTENTS-CONT

	Paragraph	Page
Front Marker Light and Bracket Assembly		
Removal and Replacement	7-34	7-139
Removal	7-34a	7-139
Replacement	7-34b	7-141
Front Marker Lamps Removal and Replacement..	7-35	7-144
Removal	7-35a	7-144
Replacement	7-35b	7-145
Front Marker Light Repair	7-36	7-146
Preliminary Procedures	7-36a	7-146
Disassembly	7-36b	7-146
Cleaning, Inspection, and Repair	7-36c	7-147
Assembly	7-36d	7-148
Floodlight and Bracket Assembly Removal,		
Repair, and Replacement (Truck M756A2)	7-37	7-149
Removal	7-37a	7-149
Cleaning, Inspection, and Repair	7-37b	7-150
Replacement	7-37C	7-150
Floodlight Housing Removal, Repair, and		
Replacement (Truck M756A2)	7-38	7-151
Preliminary Procedure	7-38a	7-151
Removal	7-38b	7-151
Cleaning, Inspection and Repair	7-38c	7-152
Replacement	7-38d	7-153
Floodlight Sealed B earn Removal, Repair,		
and Replacement	7-39	7-154
Removal	7-39a	7-154
Cleaning, Inspection, and Repair.	7-39b	7-156
Replacement	7-39C	7-156
Front Composite Light and Bracket Assembly		
Removal and Replacement	7-40	7-158
Removal	7-40a	7-158
Replacement	7-40b	7-160
Front Composite Lamps Removal and		
Replacement	7-41	7-163
Removal	7-41a	7-163
Replacement	7-41b	7-164
Front Composite Light Repair	7-42	7-165
Preliminary Procedures	7-42a	7-165
Cleaning, Inspection and Repair	7-42b	7-166
Rear Composite Light and Bracket Assembly		
Removal and Replacement	7-43	7-167
Preliminary Procedure	7-43a	7-167
Removal	7-43b	7-167
Replacement	7-43C	7-169
Rear Composite Light Repair	7-44	7-171
Preliminary Procedures	7-44a	7-171
Cleaning, Inspection, and Repair	7-44b	7-172

TABLE OF CONTENTS-CONT

		Paragraph	Page
	Rear Composite Lamps Removal and Replacement	7-45	7-173
	Removal	7-45a	7-173
	Replacement	7-45b	7-174
	Service and Blackout Clearance Lights Removal and Replacement (Truck M756A2)	7-46	7-175
	Removal	7-46a	7-175
	Replacement	7-46b	7-177
	Service and Blackout Clearance Lamps Removal and Replacement.	7-47	7-179
	Removal	7-47a	7-179
	Replacement	7-47b	7-180
Section VI.	Sending Unit Gages and Warning Buzzers		7-181
	Water Temperature Transmitter Removal and Replacement	7-48	7-181
	Preliminary Procedures	7-48a	7-181
	Removal	7-48b	7-181
	Replacement	7-48c	7-182
	Oil Pressure Transmitter Removal and Replacement	7-49	7-183
	Preliminary Procedure	7-49a	7-183
	Removal	7-49b	7-183
	Replacement	7-49c	7-184
	Fuel Gage Sending Unit Removal and Replacement	7-50	7-185
	Preliminary Procedures	7-50a	7-185
	Removal	7-50b	7-185
	Replacement	7-50c	7-186
	Low Air Pressure Buzzer Removal and Replacement	7-51	7-188
	Removal	7-51a	7-188
	Replacement	7-51b	7-189
Section VII.	Horn Assembly		7-190
	Horn Button Removal, Repair, and Replacement	7-52	7-190
	Preliminary Procedures.	7-52a	7-190
	Removal	7-52b	7-190
	Repair	7-52c	7-193
	Cleaning	7-52d	7-193
	Replacement	7-52e	7-193
	Air Horn and Solenoid Removal and Replacement	7-53	7-197
	Preliminary Procedures.	7-53a	7-197
	Removal	7-53b	7-197
	Replacement	7-53c	7-199
	Electric Horn Removal and Replacement	7-54	7-202
	Preliminary Procedure	7-54a	7-202
	Removal	7-54b	7-202
	Replacement	7-54c	7-203

TABLE OF CONTENTS-CONT

		Paragraph	Page
Section VIII.	Battery System		7-205
	Servicing the Batteries	7-55	7-205
	Preliminary Procedures	7-55a	7-205
	Specific Gravity Check	7-55b	7-205
	Cleaning the Batteries	7-55C	7-207
	Storage Batteries Removal and Replacement	7-56	7-209
	Removal	7-56a	7-209
	Replacement	7-56b	7-212
	Ground Straps Removal and Replacement	7-57	7-217
	Removal	7-57a	7-217
	Replacement	7-57b	7-220
	Battery Ground Cable	7-58	7-223
	Disconnect	7-58a	7-223
	Reconnect	7-58b	7-225
Section IX.	Chassis Harness		7-227
	Generator-to-Regulator Harness Removal, Repair, and Replacement (Trucks with Engines LDS 427-2, LD 465-1, and LDT 465-1C)	7-59	7-227
	Preliminary Procedure	7-59a	7-227
	Removal .-.	7-59b	7-227
	Repair	7-59C	7-228
	Replacement	7-59d	7-229
	Trailer Connector Electrical Cable Removal and Replacement	7-60	7-230
	Removal	7-60a	7-230
	Replacement	7-60b	7-231
	Trailer Electrical Coupling Receptacle Removal and Replacement	7-61	7-232
	Removal	7-61a	7-232
	Replacement	7-61b	7-234
	Trailer Electrical Receptacle Removal and Replacement (Trucks M275A1 and M275A2)	7-62	7-236
	Removal	7-62a	7-236
	Replacement	7-62b	7-239
Section X.	Miscellaneous Items		7-242
	Directional Signal and Solid State Flasher Removal, Repair, and Replacement	7-63	7-242
	Preliminary Procedures	7-63a	7-242
	Removal	7-63b	7-242
	Repair	7-63c	7-244
	Replacement	7-63d	7-246
	Manifold Heater Switch Removal and Replacement	7-64	7-248
	Preliminary Procedure	7-64a	7-248
	Removal	7-64b	7-248
	Replacement	7-64c	7-249

TABLE OF CONTENTS-CONT

		Paragraph	Page
	Headlight Dimmer Switch Removal and Replacement	7-65	7-250
	Preliminary Procedures	7-65a	7-250
	Removal	7-65b	7-250
	Replacement	7-65c	7-252
	Floodlight Housing Switch Removal, Repair, and Replacement (Trucks M756A2 and M764).	7-66	7-254
	Preliminary Procedure	7-66a	7-254
	Removal	7-66b	7-254
	Cleaning, Inspection, and Repair	7-66c	7-255
	Replacement	7-66d	7-256
	Hydraulic Stoplight Switch Removal and Replacement (All Trucks Except Models M275A1 and M275A2)	7-67	7-257
	Removal	7-67a	7-257
	Replacement of Switch pn 7064588	7-67b	7-260
	Replacement of Switch pn 7760414 with Switch pn 7064588	7-67c	7-261
	Air Stoplight Switch Removal and Replacement (Trucks M275A1 and M275A2)	7-68	7-263
	Preliminary Procedures	7-68a	7-263
	Removal	7-68b	7-264
	Replacement	7-68c	7-265
	Low Air Pressure Buzzer Switch Removal and Replacement	7-69	7-266
	Preliminary Procedures	7-69a	7-266
	Removal	7-69b	7-266
	Type A Replacement	7-69c	7-269
	Type B Replacement	7-69d	7-270
CHAPTER 8.	TRANSMISSION SYSTEM GROUP MAINTENANCE		
Section I.	Scope		8-1
	Equipment Items Covered	8-1	8-1
	Equipment Items Not Covered	8-2	8-1
Section II.	Transmission Breather Removal and Replacement		8-1
	Transmission Breather	8-3	8-1
	Preliminary Procedure	8-3a	8-1
	Removal	8-3b	8-2
	Replacement	8-3c	8-3
CHAPTER 9.	TRANSMISSION TRANSFER SYSTEM GROUP MAINTENANCE		
Section I.	Scope		9-1
	Equipment Items Covered	9-1	9-1
	Equipment Items Not Covered.	9-2	9-1
Section II.	Transmission Transfer Control and Linkage Assembly		9-1
	Transmission Transfer Controls and Linkage With Power Takeoff Removal and Replacement (Trucks M49A1C, M49A2C, M50A1, M50A2, M50A3, M756A2, and M764)	9-3	

TABLE OF CONTENTS-CONT

	Paragraph	Page
Preliminary Procedure	9-3a	9-1
Removal of Transmission Transfer Shift Lever and Linkage (Trucks M756A2 and M764)	9-3b	9-1
Removal of Transmission Transfer Shift Lever and Linkage (Trucks M49A1C , M49A2C, M50A1, M50A2, and M50A3)	9-3C	9-2
Removal of Transmission Transfer Reverse Shift Linkage (Transfers Without Air Actuated Positive Lockup)	9-3d	9-4
Removal of Power Takeoff Shift Controls and Linkage	9-3e	9-4
Removal of Transmission Transfer Power Takeoff Shifting Lever Lockout Linkage (Trucks M49A1C, M49A2C, M50A1, M50A2, and M50A3)	9-3f	9-5
Repair of Transmission Transfer Controls and Linkage	9-3g	9-8
Replacement of Transmission Transfer Shift Lever and Linkage (Trucks M49A1C , M49A2C, M50A1, M50A2, and M50A3)	9-3h	
Replacement of Transmission Transfer Shift Lever and Linkage (Trucks M756A2 and M764)	9-3i	
Replacement of Transmission Transfer Power Takeoff Shift Controls and Linkage . . .	9-3j	9-14
Replacement of Transmission Transfer Power Takeoff Shifting Lever Lockout Linkage (Trucks M49A1C , M49A2C , M50A1, M50A2, and M50A3)	9-3k	9-16
Transmission Transfer Controls and Linkage (Without Power Takeoff) Removal, Repair, and Replacement	9-4	9-24
Preliminary Procedure	9-4a	9-24
Removal of Transmission Transfer Shift Lever and Linkage	9-4b	9-25
Removal of Transmission Transfer Reverse Shift Lever and Linkage (Transmission Transfers Without Air Actuated Positive Lockup)	9-4C	9-27
Disassembly of Transmission Transfer Reverse Shift Rod (Transmission Transfers Without Air Actuated Positive Lockup)	9-4d	
Assembly of Transmission Transfer Reverse Shift Rod (Transmission Transfers Without Air Actuated Positive Lockup)	9-4e	9-33
Repair of Transmission Transfer Controls and Linkage	9-4f	9-35

TABLE OF CONTENTS-CONT

		Paragraph	Page
	Replacement of Transmission Transfer Shift Lever and Linkage	9-4g	9-35
	Replacement of Transmission Transfer Reverse Shift Levers and Linkage (Transmission Transfers Without Air Actuated Positive Lockup)	9-4h	9-41
	Transmission Transfer Reverse Shift Linkage Check	9-5	9-45
	Preliminary Procedure	9-5a	9-45
	Transmission Transfer Reverse Shift Linkage Check	9-5b	9-45
	Transmission Transfer Reverse Shift Linkage Adjustment	9-6	9-46
	Preliminary Procedure	9-6a	9-46
	Adjustment (Forward Speed)	9-6b	9-46
	Adjustment (Reverse Speed)	9-6c	9-49
	Transmission Transfer Output Cover Seal and Air Vent Removal and Replacement	9-7	9-51
	Preliminary Procedure	9-7a	9-51
	Removal	9-7b	9-51
	Replacement	9-7c	9-52
CHAPTER 10.	PROPELLER SHAFTS GROUP MAINTENANCE		
Section I.	Scope		10-1
	Equipment Items Covered	10-1	10-1
	Equipment Items Not Covered	10-2	10-1
Section II.	Propeller Shaft Assemblies		10-1
	Propeller Shaft and Universal Joint (Intermediate Propeller Shaft) Removal and Replacement (Truck 36A2)	10-3	10-1
	Removal	10-3a	10-2
	Replacement	10-3b	10-5
	Propeller Shaft and Universal Joints Removal and Replacement (All Except Intermediate Propeller Shaft On Truck M36A2)	10-4	10-9
	Removal	10-4a	10-9
	Replacement	10-4b	10-10
	Universal Joint (Snapping, C-Ring, and Bearing Cap Type) Repair	10-5	10-12
	Disassembly (Snapping and C-Ring Type)	10-5a	10-12
	Disassembly (Bearing Cap Type)	10-5b	10-15
	Cleaning (All Types)	10-5c	10-20
	Inspection and Repair (All Types)	10-5d	10-20
	Assembly (Snapping and C-Ring Type)	10-5e	10-21
	Assembly (Bearing Cap Type)	10-5f	10-24
CHAPTER 11.	FRONT AXLE GROUP MAINTENANCE		
Section I.	Scope		11-1
	Equipment Items Covered	11-1	11-1
	Equipment Items Not Covered	11-2	11-1

TABLE OF CONTENTS-CONT

	Paragraph	Page
Section II. Front Axle Assembly		
Jacking and Supporting Axle Housing	11-3	
Jacking and Supporting Front Axle Housing	11-3a	11-2
Removal of Front Axle Housing Supports.	11-3b	11-3
Jacking and Supporting Rear Axle Housing	11-3c	11-4
Removal of Rear Axle Housing Supports	11-3d	11-5
Jacking and Supporting Truck Chassis	11-4	11-6
Raising Front Chassis	11-4a	11-6
Lowering Front Chassis	11-4b	11-7
Raising Rear of Chassis (One Side).	11-4c	11-8
Lowering Rear of Chassis (One Side)	11-4d	11-9
Raising Rear of Chassis (Both Sides)	11-4e	11-10
Lowering Rear of Chassis (Both Sides).	11-4f	11-11
Front Axle Shaft Assembly Removal and Replacement	11-5	11-12
Preliminary Procedures	11-5a	11-12
Removal	11-5b	11-12
Replacement	11-5c	11-14
Section III. Steering Mechanism		
Steering Knuckle Boot Removal and Replacement	11-6	
Removal	11-6a	
Replacement	11-6b	11-22
CHAPTER 12. REAR AXLE GROUP MAINTENANCE		
Section I. Scope		12-1
Equipment Items Covered	12-1	12-1
Equipment Items Not Covered	12-2	12-1
Section II. Rear Axle Assembly		12-1
Rear Axle Shaft Removal and Replacement.	12-3	12-1
Removal	12-3a	12-1
Replacement	12-3b	12-3
Rear Axle Breather Valve Removal and Replacement	12-4	12-4
Removal	12-4a	12-4
Replacement	12-4b	12-5

TABLE OF CONTENTS-CONT

PART 2 OF 4		Paragraph	Page
(TM 9-2320 -209-20-3-2)			
CHAPTER 13.	BRAKE SYSTEM GROUP MAINTENANCE		13-1
Section I.	Scope		13-1
Section II.	Handbrake Assembly and Related Parts		13-1
Section III.	Service Brake		13-49
Section IV.	Hydraulic Brake System		13-73
Section V.	Mechanical Brake System		13-134
Section VI.	Air Brake System		13-148
Section VII.	Compressed Air System		13-237
Section VIII.	Trailer Brake Connections		13-267
CHAPTER 14.	WHEEL GROUP MAINTENANCE.		14-1
Section I.	Scope		14-1
Section II.	Front Wheel Assembly		14-1
Section III.	Rear Wheel Assembly		14-46
Section IV.	Tires		14-78
CHAPTER 15.	STEERING SYSTEM GROUP MAINTENANCE		15-1
Section I.	Scope		15-1
Section II.	Mechanical Steering Gear Assembly		15-1
CHAPTER 16.	FRAME AND TOWING ATTACHMENTS GROUP MAINTENANCE		16-1
Section I.	Scope		16-1
Section II.	Pintle and Towing Attachments		16-1
Section III.	Spare Wheel Carrier		16-17
Section IV.	Fifth Wheel Assembly		16-48
CHAPTER 17.	SPRINGS AND SHOCK ABSORBERS GROUP MAINTENANCE		17-1
Section I.	Scope		17-1
Section II.	Springs		17-1
Section III.	Shock Absorbers		17-11
Section IV.	Torque Rods		17-12
PART 3 OF 4			
(TM 9-2320 -209-20-3-3)			
CHAPTER 18.	BODY , CAB , HOOD, AND HULL GROUP MAINTENANCE		18-1
Section I.	Scope		18-1
Section II.	Cab Components		18-1
Section III.	Windshield Assembly		18-14
Section IV.	Seats		18-18
Section V.	Brackets and Straps		18-46
Section VI.	Cargo Body Components		18-48
Section VII.	Tank Body Components		18-67
Section VIII.	Special Purpose Bodies		18-359

TABLE OF CONTENTS-CONT

Paragraph Page

PART 4 OF 4
(TM 9-2320-209-20-3-4)

CHAPTER 19.	WINCH AND HOIST ASSEMBLIES AND POWER TAKEOFF CONTROLS AND LINKAGE GROUP MAINTENANCE	19-1
Section I.	Scope	19-1
Section II.	Winch and Hoist Assemblies.....	19-1
Section III.	Power Takeoff Controls and Linkage	19-129
CHAPTER 20.	BUMPER GUARDS GROUP MAINTENANCE	20-1
Section I.	Scope	20-1
Section II.	Bumper Brackets, Guards, and Protective Devices	20-1
CHAPTER 21.	BODY ACCESSORY ITEMS GROUP MAINTENANCE	21-1
Section I.	Scope	21-1
Section II.	Canvas Accessory Items	21-1
Section III.	Cab Accessory Items	21-4
Section IV.	Data Plates	21-24
CHAPTER 22.	NONELECTRICAL GAGES GROUP MAINTENANCE	22-1
Section I.	Scope	22-1
Section II.	Nonelectrical Gages	22-1
CHAPTER 23.	MAINTENANCE OF MATERIAL USED IN CONJUNCTION WITH MAJOR ITEMS	23-1
Section I.	Scope	23-1
Section II.	Winterization Kits	23-1
Section III.	Deep Water Fording Kit	23-103
Section IV.	Special Purpose Kits	23-120
APPENDIX A.	REFERENCES	A-1
INDEX	Index 1

CHAPTER 1

GENERAL MAINTENANCE INFORMATION

1-1. SCOPE . This manual contains the organizational maintenance instructions for the trucks listed below. This manual includes procedures for disassembly, cleaning, inspection, repair, test and adjustment as authorized by the maintenance allocation chart.

Truck, Cargo: 2 1/2 ton, 6x6, M35A1, M35A2, M35A2C, and M36A2
 Truck, Dump: 2 1/2 ton, 6x6, M342A2
 Truck, Tractor: 2 1/2 ton, 6x6, M275A1 and M275A2
 Truck, Tank, Fuel: 2 1/2 ton, 6x6, M49A1C and M49A2C
 Truck, Tank, Water: 2 1/2 ton, 6x6, M50A1, M50A2, and M50A3
 Truck, Repair Shop: 2 1/2 ton, 6x6, M185A2 and M185A3
 Truck, Van, Shop: 2 1/2 ton, 6x6, M109A2 and M109A3
 Truck, Maintenance, Earth Boring and Polesetter: 2 1/2 ton, 6x6, M764
 Truck, Maintenance, Pipeline Construction: 2 1/2 ton, 6x6, M756A2

Information is provided on maintenance of trucks which is beyond the scope of tools, equipment, **personnel, or supplies normally available to the operator or using organization.**

1-2. GENERAL MAINTENANCE . The general maintenance and repair covered by other manuals and called out in this manual are as follows:

TM 9-214 Inspection, Care and Maintenance of Antifriction Bearings.
 TM 9-237 Operator's Manual: Welding Theory and Application (TO 34W4-1-5).
 FM 43-3 General Repair for Canvas and Webbing.
 TM 9-247 Materials Used for Cleaning, Preserving, Abrading and Cementing
 Ordnance Materiel and Related Materials Including Chemicals.
 FM 43-2 Metal Body Repair and Related Operations.
 TB 750-254 Cooling Systems: Tactical Vehicles Changes 1, 2.
 TB 43-0212 Purging, Cleaning and Coating Interior Ferrous and Terne
 Sheet Vehicle Fuel Tanks
 TM 43-0139 Painting Instructions for Field Use.
 TB 43-0209 Color, Marking and Camouflage Painting of Military Vehicles,
 Construction Equipment, and Materials Handling Equipment.
 TB 43-0213 (Rustproofing)
 TM 9-2300-422-20 Security-of Tactical Wheeled Vehicles.

1-3. CLEANING . All parts must be cleaned before inspection and assembly and after repair.

WARNING

Dry cleaning solvent is flammable. Do not use near an open flame. Keep a fire extinguisher nearby when solvent is used. Use only in well-ventilated places. Failure to do this may result in injury to personnel and damage to equipment.

Clean inner and outer surfaces of metallic parts and all areas subject to oil or grease with dry cleaning solvent, type II (SD-2), Fed. Spec P-D-680. Clean out sludge and gum with a stiff brush. Use steam cleaning to take off accumulated grease and dirt after dry cleaning solvent has been applied. Dry with clean rags. To clean bearings,

refer to TM 9-214. The general cleaning covered by other manuals and references called out in this manual are as follows:

TM 9-247 Materials Used for Cleaning, Preserving, Abrading and Cementing Ordnance Materiel and Related Materials Including Chemicals.

TM 9-214 Inspection, Care and Maintenance of Antifriction Bearings.

1-4. PAINTING. Instructions for the preparation of the material for painting, how to paint, and material to be used are in TM 43-0139. Instructions for camouflage painting are contained in TB 43-0209. Stenciling and marking must be done periodically due to weathering or repainting. Instructions for marking military trucks is called out in TB 43-0209.

1-5. AIR SYSTEM LEAKAGE TEST . The following procedures give instructions for checking the compressed air system for leaks. These instructions are of a general nature and are given here so that they do not have to be repeated throughout chapter 12.

a. With compressed air system filled, brush each air line and fitting with soapy water.

b. If air bubbles appear, line or fitting is leaking.

c. Tighten fitting just enough to stop leak and do steps a and b again.

d. If you still have a leak, remove and replace line or fitting.

1-6. TORQUE VALUES . Critical torque values for a particular component are given in the maintenance procedures. When torque values are not given, bolts, screws, and nuts are to be tightened as given in table 1- 1.

1-7. SPECIAL TOOLS AND EQUIPMENT . Special tools and equipment are provided to make it easier to do particular maintenance tasks and to keep the truck in good repair. Table 1-2 lists the special tools and equipment and gives a reference to the maintenance paragraph where they are used and what they are used for.

1-8. COMMON TOOLS. In the maintenance procedures covered in this manual, specific wrench sizes have been given, However, due to modifications made to equipment in the field or in production at the factory, you may need different wrench sizes.

1-9. SAFETY INSPECTION AND TESTING OF LIFTING DEVICES. Refer to TB 43-0142 for safety inspection and testing of lifting devices used in this manual.

1-10. FORMS AND RECORDS . Maintenance forms, records, and reports which are to be used by maintenance personnel at all levels are listed in and prescribed by TM 38-750.

1-11. EQUIPMENT IMPROVEMENT REPORT AND MAINTENANCE DIGEST (EIR MD) AND EQUIPMENT IMPROVEMENT REPORT AND MAINTENANCE SUMMARY (EIR MS). The quarterly Equipment Improvement Report and Maintenance Digest, TB 43-0001-39 series, contains valuable field information on the equipment covered in this manual. The information in the TB 43-0001-39 series is compiled from some of the Equipment Improvement Reports that you prepared on the vehicles covered in this manual. Many of these articles result from comments, suggestions, and improvement recommendations that you submitted to the EIR program. The TB 43-0001-39 series contains information on equipment improvements, minor alterations, proposed Modification Work Orders (MWO' s) , warranties (if applicable) , actions taken on some of your DA Form 2028's (Recommended Changes to Publications) , and advance information on proposed changes

Table 1-1. Standard Torque Specifications

USAGE	MUCH USED	MUCH USED	USED AT TIMES	USED AT TIMES
CAPSCREW DIAMETER AND MINIMUM TENSILE STRENGTH PSI [KG/SQ CM]	To 1/2-69,000 [4850.7000]	To 3/4-120,000 [8436.0000]	To 5/8- 140,000 [9842.0000]	150,000 [10545.0000]
	To 3/4-64,000 [499.2000]	To 1 -115,000 [8084.5000]	To 3/4-133,000 [9349.9000]	
	To 1 -55,000 [3866.5000]			
QUALITY OF MATERIAL	INDETERMINATE	MINIMUM COMMERCIAL	MEDIUM COMMERCIAL	BEST COMMERCIAL
SAE GRADE NUMBER	1 or 2	5	6 or 7	8

CAPSCREW HEAD MARKINGS

Manufacturer's marks may vary
These are all SAE Grade 5
(3-line)

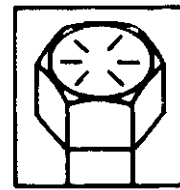
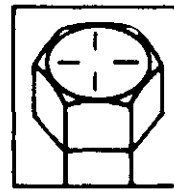
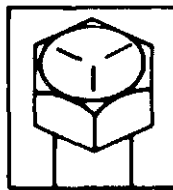
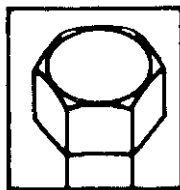

CAPSCREW BODY SIZE (INCHES)-(THREAD)	TORQUE FT.LB [KG M]		TORQUE FT.LB [KG M]		TORQUE FT.LB [KG M]		TORQUE FT-LB [KG M]	
1/4-20	5	[0.6915]	8	[1.1064]	10	[1.38301]	12	[1.6596]
-28	6	[0.8293]	10	[1.3830]			14	[1.9362]
5/16-18	11	[1.5213]	17	[2.3511]	19	[2.6277]	24	[3.3192]
-24	13	[1.7979]	19	[2.6277]			27	[3.7341]
3/8-16	18	[2.4894]	31	[4.2873]	34	[4.7022]	44	[6.0852]
-24	20	[2.7660]	35	[4.8405]			49	[6.7767]
7/16-14	28	[3.8132]	49	[6.7767]	55	[7.6065]	70	[9.6810]
-20	30	[4.1490]	55	[7.6065]			78	[10.7874]
1/2-13	39	[5.3937]	75	[10.3725]	85	[11.7555]	105	[14.5215]
-20	41	[5.6703]	85	[11.7555]			120	[16.5960]
9/16-12	51	[7.0533]	110	[15.2130]	120	[16.5960]	155	[21.4365]
-18	55	[7.6065]	120	[16.5960]			170	[23.5110]
5/8-11	83	[11.4769]	150	[20.7450]	167	[23.0961]	210	[29.0430]
-18	95	[13.1385]	170	[23.5110]			240	[33.1920]
3/4-10	105	[14.5215]	270	[37.3410]	280	[38.7240]	375	[51.8625]
-16	115	[15.9045]	295	[40.7985]			420	[58.0860]
7/8-9	160	[22.1280]	395	[54.6285]	440	[60.8520]	605	[83.67151]
-14	175	[24.2025]	435	[60.1605]			675	[93.3525]
1-8	235	[32.5005]	590	[81.5970]	660	[91.2780]	910	[125.8530]
-14	250	[34.5750]	660	[91.2780]			990	[136.9170]

1. Always use the torque values listed above when specific specifications are not available

Note: Do not use above values in place of those specified in the engine groups of this manual, special attention should be observed in case of SAE Grade 6, 7 and 8 capscrews

- 2 The above is based on use of clean and dry threads
- 3 Reduce torque by 10% when engine oil is used as a lubricant.
- 4 Reduce torque by 20% if new plated capscrews are used

Caution: Capscrews threaded into aluminum may require reductions in torque of 30% or more, unless inserts are used.

TA 113439

Table 1-2. Special Tools and Equipment

Item	Part No.	National Stock No.	Reference Paragraph	Used
PULLER, STEERING wheel	7083305	5120-00-708-3305	15-10	Used to take off steering wheel.
REMOVER AND REPLACER: (Wheel Bearing Cup or Rear Seat Bearing cup)	7082863	5120-00-473-7372	14-6 17-9 17-10	Used to put on wheel bearing. Used to put on and take off rear spring seat cup.
REPLACER , OIL SEAL	C-10937827	5120-00-947-2232	14-10 14-11 17-8 17-10	Used to put back wheel hub inner oil seal. Used to put back rear spring seat cross shaft oil seal.
SCREW , REMOVER AND REPLACER	7083216	5120-00-708-3216	17-9	Used with remover and replacer 5120-00-473-7372 to take off rear spring seat cup.
WRENCH , PULLEY ADJUSTING: (Air Compressor Pulley)	10935288	5120-00-070-7809	13-34	Used for adjusting air compressor pulley.
WRENCH , WHEEL BEARING NUT	7076869	5120-00-104-4076	14-3 14-4 14-8 14-9 17-8	Used to take off and put on wheel bearing nut and rear spring seat locknut.

that may affect this manual. In addition, the more maintenance significant articles, including minor alterations, field-fixes, etc, that have a more permanent and continuing need in the field are republished in the Equipment Improvement Report and Maintenance Summary (EIR MS) for TARCOM Equipment (TM 43-0143). Refer to both of these publications (TB 43-0001-39 series and TM 43-0143) periodically, especially the TB 43-0001-39 series, for the most current and authoritative information on your equipment. The information will help you in doing your job better and will help in keeping you advised of the latest changes to this manual. Also refer to DA Pam 310-4, Index of Technical Publications, and Appendix A , References, of this manual.

1-12. REPORTING IMPROVEMENT RECOMMENDATIONS . If your truck needs improvement, let us know. Send us an EIR. You, the user, are the only one who can tell us what you don't like about your equipment. Let us know why you don't like the design. Tell us why a procedure is hard to perform. Put it on an SF 368 (Quality Deficiency Report). Mail it to us at: Commander, U.S. Army Tank Automotive Material Readiness Command, ATTN : DRSTA-MT , Warren, Michigan 48090. We'll send you a reply.

1-13. METRIC SYSTEM. The equipment /system described herein is nonmetric and does not require common or special tools. Therefore, metric units are not supplied. Tactical instructions, for sake of clarity, will also remain nonmetric.

1-14. DESTRUCTION TO PREVENT ENEMY USE. Follow procedures given in TM 750- 244-6 for destruction of Army material to prevent enemy use.

1-15. VEHICLE DESCRIPTION . For vehicle description refer to TM 9-2320-209-10.

1-16. TABULATED DATA . Data is detailed in subparagraphs a through j below for the 2 1/2 ton, 6x6, series trucks. Detailed data is the same for all models, except as noted.

a. Engine and Cooling System.

Models	U.S. Army (LD-465-1, LD-465-1C , LDT-465-1C)
Cylinders (in-line).....	6
Brake horsepower (gross @ 2,600 rpm)	140
Torque (gross, minimum, pound-feet):	
LD-465-1, LD-465-1C and	
LDT-465-1C at 1,500 rpm)	305
Ignition system	Compression
Firing order	1-5-3 -6-2-4
Idle speed:	
Except LDT-465-1C	650-700rpm
LDT-465-1C	800-850 rpm
Cooling	Liquid
Radiator:	
Ord No.	10876110
Radiator filler cap:	
Ord No.	MS35840-1
Opening pressure	6 1/2 to 8 psi
Opening vacuum	0 to 1/4 psi
Coolant capacity (quarts)	28-32
Thermostat	
Ord No.	10911114
Starts to open	180°F
Fully opened	200°F
Compression ratio	22:1
Piston stroke	4.87 in.
Fan and water pump drive belt (set of two matched belts) :	
Ord No.	5702650
Type	Notched V
Length	46 in.
Oil filters: 2	
Ord No.	8748329

Water pump:
 Ord no. 10951101
 Type Centrifugal
 Displacement (cu. in) 478
 Weight (dry, with accessories):
 Except LDT-465-1C 1,500 lbs
 LDT-465-1C 1,600 lbs

b. Electrical System.

Alternator (Generator) (60 ampere):
 Ord no. 10929868
 Regulator Built-in (solid-state)
 Voltage (adjustable) 27-31 volts
 Recoverability after load deviation 0.6 sec
 Temperature variables (at rated output) -65° to +250°F
 Output, minimum (hot) 23 amp at 1000 rpm

Generator:
 Ord no. 10950808
 Capacity 25 amp

Generator-regulator:
 Ord no. 11631857
 Operating voltage 24-28 v dc
 Type vibrating
 Voltage (rated) 24
 Ground polarity negative

Voltage regulator:
 Operating range (hot) 27-29 v

Current regulator:
 Operating range (hot) 22-25 amp

Cutout relay:
 Closing range (hot) 24.5 -26.5 v

Batteries (2 in series) :
 Ord no. MS35000-3
 Voltage (each) 12
 Ground negative
 Plates per cell 23
 Capacity 20 hr rate, 100 amp hr
 Specific gravity at full charge at 80°F 1.275 to 1.280

Starter:
 Ord no. (Delco-Remy) 10911018-1
 Voltage 24 v dc
 Torque (lock min) 16 lb-ft (at 500 amps,
 3.5 volts) Pinion rotation (facing
 drive-end) clockwise

Number of teeth on clutch assembly (pinion)
 (one tooth blank) 12
 Number of mounting holes... 3
 Diameter of mounting holes 0.6592 in.
 Mounting hole circle diameter 5.75 in.
 Length 19.96 + 0.12 in.
 Diameter (field frame) 5.56+ 0.04 in.
 Weight (approx.) 65 lbs.

Ord no. (Leece-Neville) 10935376
 Voltage 24 dc
 Current at rated load (rated max) 500 amps
 Horsepower (rated) 8.5 hp at 2550 rpm
 Stall torque 106 lb-ft
 Pinion rotation (facing drive end) clockwise
 Number of pinion teeth (one tooth blank) 12
 Mounting data:
 Number of mounting holes 3
 Diameter of mounting holes 0.656 in.
 Mounting holes circle dia. 5.75 in.
 Length 18.72 in.
 Height 9.34 in.
 Diameter (field ring) 5.12 in.
 Weight 63 lbs
 Lamps:
 Ord no. (headlamp) MS18008-4863
 Ord no. (blackout) MS15570-1251
 Ord no. (turn signal) MS35478-1683
 Ord no. (parking) MS15570-623

c. Clutch, Transmission, Transfer, Propeller Shaft and Axles.

Axle, front:
 Ord no. 7521734
 Type Double reduction
 Axle, rear:
 Ord no. 7368511
 Type Double reduction
 Clutch :
 Ord no. 7748995
 Type dry, single plate
 Power transfer:
 Ord no. 11609226
 Model T-136-21
 Type 2-speed synchromesh
 Lubricant capacity 7 qts
 Power transfer w /air actuated positive lock-up :
 Ord no. 11609224
 Model T-136-27
 Type 2-speed synchromesh
 Lubricant capacity 7 qts
 Propeller shafts:
 Forward rear to rear-rear:
 Ord no. 7521035
 Transfer to front axle:
 Ord no. 7521043
 Transfer to forward rear axle (except on M275A1 and M275A2) :
 Ord no. 7061097
 Transfer to forward rear axle:
 Ord no. 7521013

Transmission to transfer assembly:
 Ord no. 7521000
 Transmission:
 Ord no. (Spicer) 10872096
 Type synchromesh
 Speeds
 Forward 5
 Reverse 1
 Transfer power takeoff Rockwell-Standard P-136-C
 Transmission power takeoff (single-ended) :
 Make Spicer
 Model WN-7-28
 Transmission power takeoff w/accessory drive
 (double-ended):
 Make Spicer
 Model WND-7-28

d. Suspension.

Springs, front:
 Ord no. 7368628
 Type, leaf Semielliptic
 Springs, rear:
 Ord no. 7521792
 Type, leaf Semielliptic
 Shock absorbers:
 Ord no. 7539007
 Location Front only
 Type Direct, double acting

e. Braking system.

Air compressor:
 Air-cooled:
 Ord no. (Midland-Ross) MS51322-1
 Type 5400B
 Displacement per minute at 1250 rpm 7¼ cu ft
 Number of cylinders 2
 Lubrication engine lubricated
 Air governor:
 Ord no. (Bendix-Westinghouse) 10900525
 Service brakes:
 Type Air over hydraulic
 Parking brake:
 Model Timken Duo-Grip mounted on transfer

f. Steering.

Model Ross TA-66
 Ord no. 7521481
 Type Cam and twin lever

g. Winch.

Front winch:
 Ord no. 7538687
 Model CA 514
 Make Gar Wood
 Capacity 10,000 lbs

Rear winch:
 Ord no. (M764) 11623130
 Make Gar Wood
 Capacity 15,000 lbs

h. Fuel System and Grades.

Air cleaner filter element:
 Ord no. 10912373

Fuel filter element:
 Ord no. 11610298

Fuel system:
 Type of system American Bosch PSB fuel injection system
 Model PSB6A85GH-5250B

i. Fuel System and Grades.

Air cleaner filter element:
 Ord no. 10912373

Fuel filter element:
 Ord no. 11610298

Fuel system:
 Type of system American Bosch PSB fuel injection system
 Model PSB6A85GH-5250B

Fuel:
 Type of fuel specification
 Compression-ignition MIL-F-4512A

Diesel fuel (Grade DFA)
 (Spec. VV-F-800) All temperatures

Diesel fuel (Grade DF1) Spec
 VV-F-800) Do not use below -10°F

Diesel fuel (Grade DF2) (Spec
 VV-F-800) Do not use below +32°F

Marine fuel oil
 (MIL-F-16884) Above 10°F

Jet fuel
 (MIL-J-5624)
 Commercial aviation
 (Jet A and Jet A1)
 Combat gasoline
 (MIL-G-3056) Emergency fuel

NOTE

Mixing fuels is allowed but, do not use aviation grade gasoline.

j. Tire inflation (9: 00 x 20).

Conditions:

Highway (psi)	50
Cross-country (psi)	35
Mud, snow, and sand (psi).....	15

NOTE

In areas where temperatures reach - 50°F or colder, put air in truck tires, 20 pounds above normal. This should be done if there are long standby periods or when parked overnight. Lower tire pressures to normal before moving truck again.

1-17. SERVICE UPON RECEIPT OF MATERIEL.

a. General.

(1) Upon receipt of a new, used or reconditioned truck, the receiving organization must see if the truck has been properly prepared for service and in good condition. Inspect all assemblies, subassemblies and accessories to be sure they are in proper working order. Secure, clean, and correctly adjust and /or lubricate as needed. Check all tools and equipment to be sure every item is there, in good condition, clean and properly mounted or stowed. Refer to TM 9-2320-209-10-1. Follow general procedure for all services and inspections given in TM 9-2320-209-10-1.

(2) The operator will help do these services.

(3) Refer to TM 9-2320- 209-10-1 for operating instructions.

b. Inspection and Servicing Equipment.

(1) General Procedures.

(a) When a truck is received, inspect all items for damage that may have occurred during shipping and unloading operations. Pay close attention to any loose or missing nuts, bolts, screws, access plates, drainplugs, draincocks, oil plugs, assemblies, subassemblies, or components that may be easily lost or broken in transit. Check basic issue items against check list to make sure all items are there and are in good condition and carefully list all discrepancies. Refer to TM 9-2320-209-10.

WARNING

Dry cleaning solvent is flammable. Do not use near an open flame. Keep a fire extinguisher nearby when solvent is used. Use only in well-ventilated places. Failure to do this may result in injury to personnel and damage to equipment.

(b) Clean all exterior surfaces coated with rust-preventive compound. Use dry cleaning solvent or mineral spirits paint thinner.

(c) Read "Processing and Reprocessing Record of Shipping, Storage, and Vehicles and Spare Engines. " tag (DD Form 1397) : and follow all precautions checked on it. This tag should be attached to the steering wheel, shifting levers or battery switch.

NOTE

If the truck has been driven to the using organization, most or all of the above work should have been done.

(2) Specific Procedures.

(a) Do the S (six-month or 6,000 mile) preventive maintenance service. Refer to TM 9-2320-209-20-1.

(b) Lubricate those points shown in LO 9-2320-209-12/1 regardless of interval. Do not lubricate gear cases and engine. Check processing tag for gear case and engine oil. If the tag states that the oil is good for 500 miles of operation and is of the proper grade for local climatic operation, do not change the oil. Just check level.

(c) Schedule an S service on DD Form 314 (Preventive Maintenance Schedule and Record Card.) Arrange for an oil change at 500 miles.

(d) If the truck is delivered with a dry charged battery, activate it. (Refer to TM 9-6140 -200-12.)

(e) Check radiator coolant. Check if solution is good for climatic conditions. Refer to table 1-3 for preparation of antifreeze solutions.

NOTE

Put a tag near filler cap. Write type of anti-freeze and degree of protection on tag.

1-18. TOOLS AND EQUIPMENT . Basic tools and repair parts issued or authorized for tools covered by this manual are listed in the Basic Issue Items List, appendix B of TM 9-2320-209-10-1.

1-19. MAINTENANCE REPAIR PARTS . Repair parts are supplied to Organizational Maintenance for the replacement of parts that are worn , broken , defective, or otherwise not usable. These parts are listed in TM 9-2320-209-20P.

1-20. GENERAL LUBRICATION INSTRUCTIONS . LO 9-2320-209-12/1 gives cleaning and lubrication procedures for trucks covered in this manual. The instructions include types and grades of lubricants used, lube points or locations and frequency of lubrication as given in with the maintenance allocation chart and lubrication order. If any of the petroleum fuels, lubricants or preserving materials are not giving proper service, report the items as given in TM 38-750.

1-21. ADMINISTRATIVE STORAGE. Refer to TM 740- 90-1 for truck storage procedures.

Table 1-3. Guide for Preparation of Antifreeze Solution

Lowest expected ambient temperature (°F)	Ethylene-glycol (-60°F) inhibited (O-A-548, type 1)		Arctic grade anti-freeze (-90°F) MIL-A-11755
	Pints per gallon of coolant capacity (Notes 1, 2)	Specific gravity (68°F)	
+20	0.750	1.022	Freezing point of -90°F Issued ready for use and must not be mixed with any other liquid
+10	1.000	1.036	
0	1.375	1.047	
-10	1.625	1.055	
-20	1.750	1.062	
-30	2.000	1.067	
-40	2.125	1.073	
-50	2.250		
-60	2.375		
Below -60	Use arctic grade antifreeze (-90°F)		

NOTES :

- Includes heaters.
- Proportions are in terms of ethylene-glycol per gallon and not pints of ethylene-glycol added to each gallon of water. For example, at -30°F a gallon of coolant contains two pints of ethylene-glycol and six pints of water (2 pints + 6 pints = 8 pints = 1 gallon).

CHAPTER 2

ENGINE SYSTEM GROUP MAINTENANCE

Section I. SCOPE

2-1. EQUIPMENT ITEMS COVERED . This chapter gives equipment maintenance procedures for the engine assembly and engine lubrication system for which there are authorized corrective maintenance tasks at the organizational maintenance level.

2-2. EQUIPMENT ITEMS NOT COVERED . All equipment items for which corrective maintenance is authorized at the organizational maintenance level are covered in this chapter.

Section II. ENGINE ASSEMBLY

2-3. FRONT ENGINE MOUNTS REMOVAL AND REPLACEMENT.

NOTE

The following tasks are the same for the left and right front engine mounts.

TOOLS : Hydraulic jack
15/16-inch socket wrench
3/4-inch open end wrench (2)
Lead or bronze hammer
Flat-tip screwdriver

SUPPLIES : Wood block (2)

PERSONNEL : One

EQUIPMENT CONDITION : Truck parked, engine off, handbrake set, wheels chocked.

Preliminary Procedure. Open hood and both side panels. Refer to TM 9-2320-209-10.

b. Identification of Engine Mounts.

FRAME 1

1. Look at engine mounts from under truck. There are two types of engine mounts (1 or 2) as shown.
2. If truck has basic engine mount (1) , refer to para 2- 3c for removal and para 2- 3d for replacement. If truck has revised engine mount (2) , refer to para 2- 3e for removal and para 2-3f for replacement.

END OF TASK

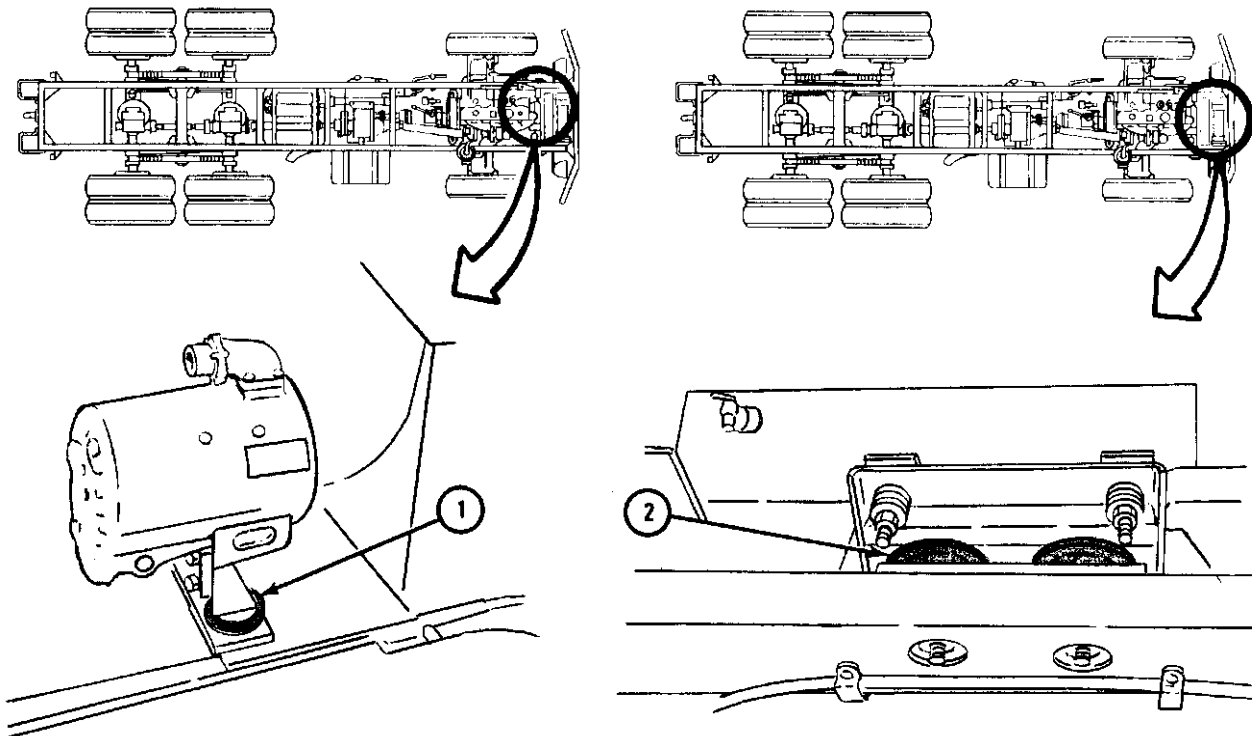

TA 047286

c. Removal (Basic Type).

FRAME 1

1. Using 3/4-inch wrenches, unscrew and take off locknut (1) from bolt (2) . Take off washer (3) and resilient mount (4) .
2. Using bronze hammer, tap bolt (2) up through bracket (5). Take out bolt and washer (6).

GO TO FRAME 2

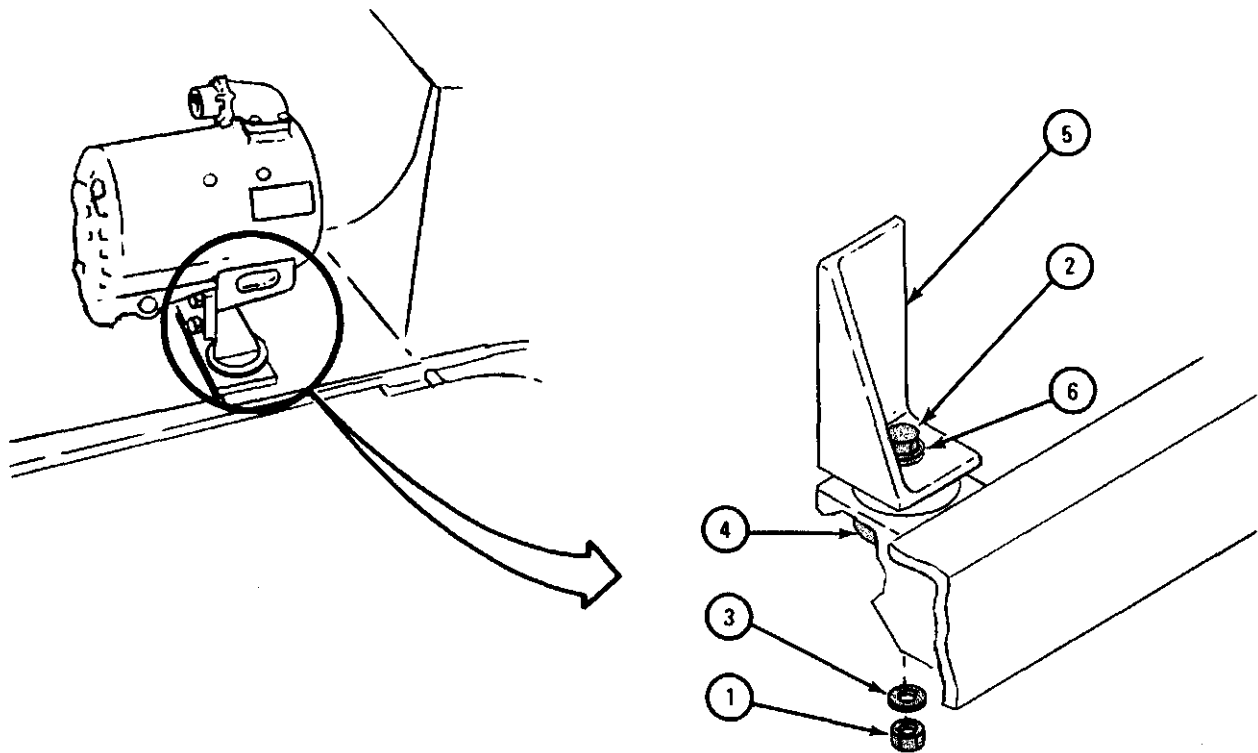

TA 047287

FRAME 2

WARNING

Do not put fingers between front mounting support (1) and bracket (2). Jack could slip, causing severe injury to personnel.

1. Set up jack (3) between two wood blocks (4) as shown.
2. Using jack, carefully raise front of engine just enough to push out upper resilient mount (5) .
3. Using screwdriver, push out upper resilient mount (5).

END OF TASK

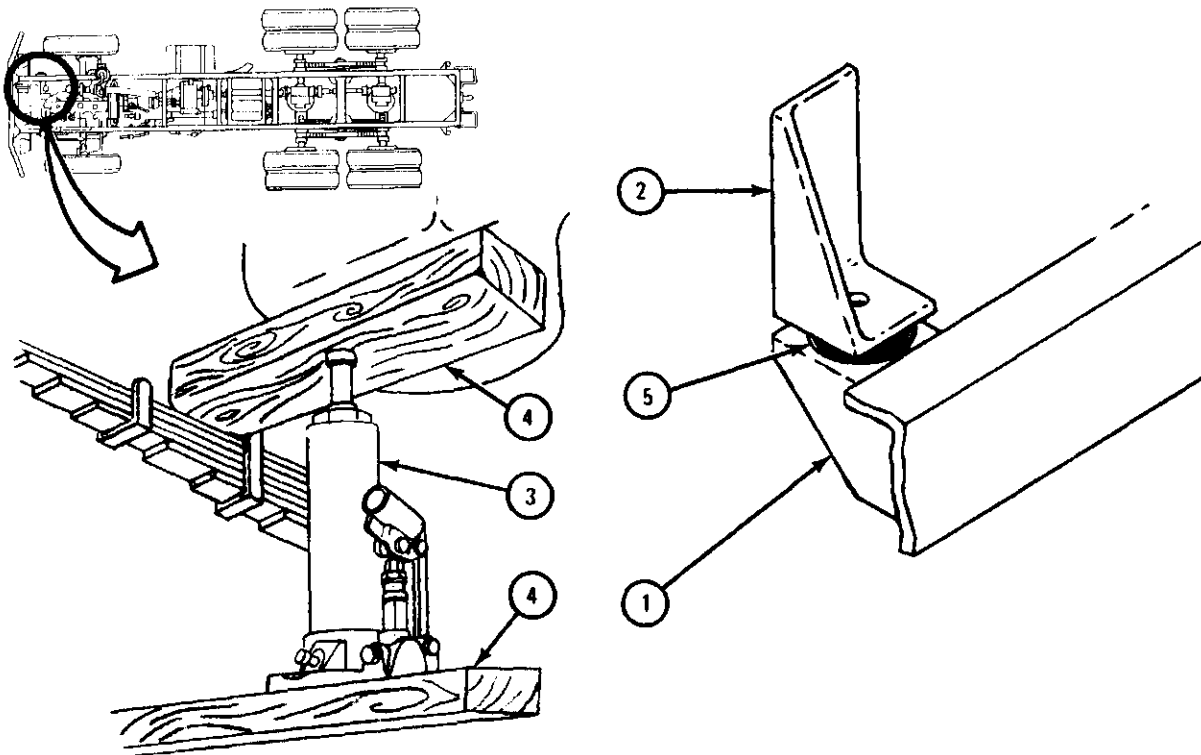

TA 047288

d. Replacement (Basic Type) .

FRAME 1

WARNING

Do not put fingers between front mounting support (1) and bracket (2) . Jack may slip , causing severe injury to personnel.

1. Put upper resilient mount (3) between front mounting support (1) and bracket (2) and aline holes.
2. Put flat washer and bolt (4) through front mounting support (1) , upper resilient mount (3) , and bracket (2) as shown.
3. Using jack, carefully lower front of engine.
4. Put lower resilient mount (5) and flat washer (6) on bolt (4).
5. Using' 3/4-inch wrenches, screw on and tighten locknut (7).

NOTE

Follow-on Maintenance Action Required:

Close hood and both side panels. Refer to TM 9-2320-209-10.

END OF TASK

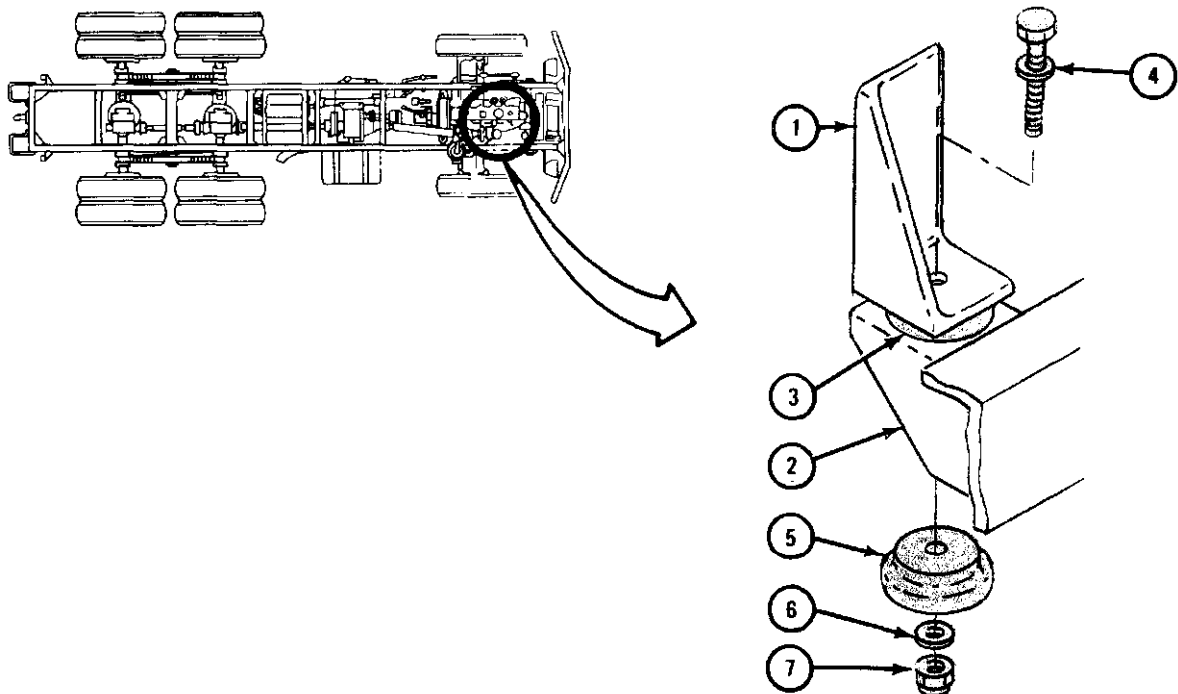

TA 047289

e. Removal (Revised Type).

FRAME 1

1. Using 3/4-inch wrench and 15/16-inch socket wrench, unscrew and take off two locknuts (1) from bolts (2). Take off two flat washers (3).
2. Using bronze hammer, tap two mounting bolts (2) up through engine and radiator mounting plate (4). Bolts will not come all the way out.

GO TO FRAME 2

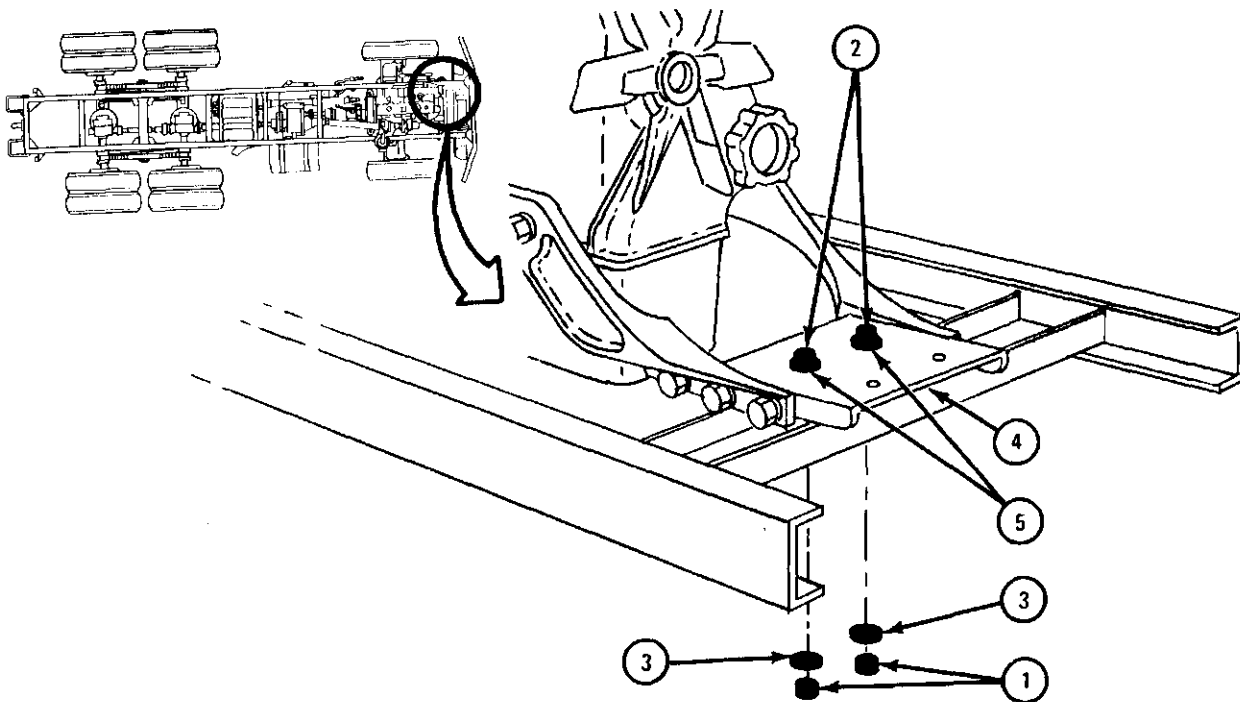

TA 047290

FRAME 2

WARNING

Do not put fingers between engine and radiator mounting plate (1) and top of crossmember (2). Jack may slip, causing severe injury to personnel.

1. Set up jack (3) between two wood blocks (4) as shown.
2. Using jack (3), carefully raise front of engine just enough to push out two upper resilient mounts (5).
3. Using screwdriver, push two upper resilient mounts (5) off top of crossmember (2).
4. Using screwdriver, push two lower resilient mounts (6) out from under crossmember (2).

END OF TASK

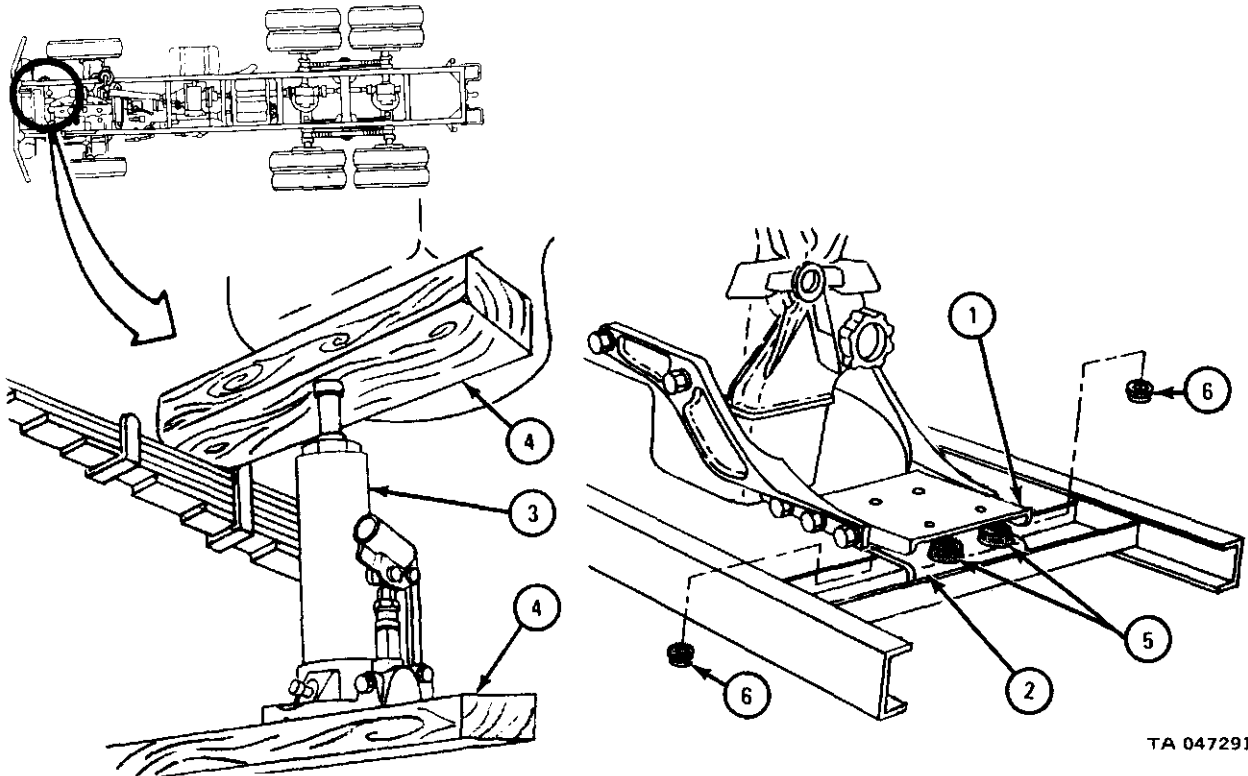

f. Replacement (Revised Type).

FRAME 1

WARNING

Do not put fingers between engine and radiator mounting plate (1) and crossmember (2). Jack may slip, causing severe injury to personnel.

1. Put two upper resilient mounts (3) between engine and radiator mounting plate (1) and crossmember (2). Aline holes in mounts with holes in crossmember.
2. Slide two lower resilient mounts (4) under crossmember (2). Use screwdriver to push mounts in place. Aline holes in mounts with holes in crossmember.
3. Reach up from behind mounting plate (1) and put two bolts with flat washers (5) through holes in engine and radiator mounting plate. Bolts must pass through upper resilient mounts (3), crossmember (2), and lower resilient mounts (4).
4. Using jack, carefully lower front of engine. Check upper resilient mounts (3) and lower resilient mounts (4) to make sure they are in place.

GO TO FRAME 2

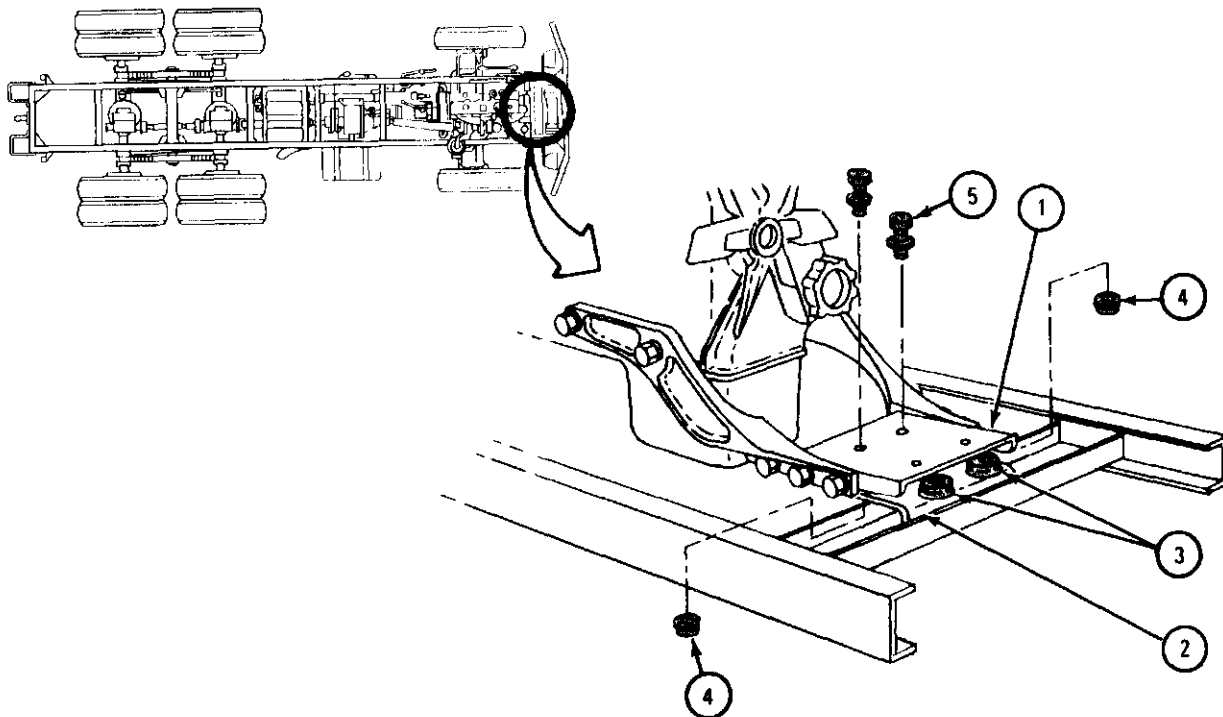

TA 047292

FRAME 2

1. Using $3/4$ -inch wrench and $15/16$ -inch socket wrench, screw on and tighten two locknuts (1) with two flat washers (2) on bolts (3).

NOTE

Follow-on Maintenance Action Required:

Close hood and both side panels. Refer to TM 9-2320-209-10.

END OF TASK

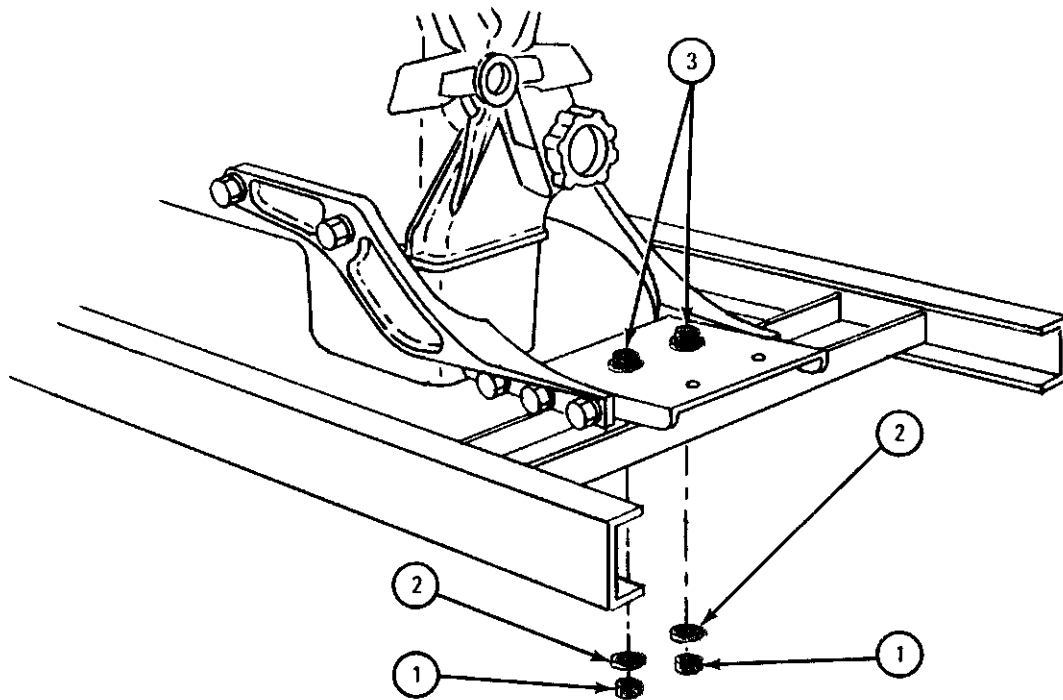

TA 047293

2-4. REAR ENGINE MOUNTS REMOVAL AND REPLACEMENT.

NOTE

This task is shown for the left rear engine mount. This task is the same for the right rear engine mount.

TOOLS : Hydraulic jack
15/16-inch socket wrench
3/4-inch open end wrench
1/2-inch open end wrench (2)
Bronze hammer

SUPPLIES : Wood block (2)

PERSONNEL : One

EQUIPMENT CONDITION : Truck parked, engine off, handbrake set, wheels chocked.

Preliminary Procedure. Open hood and both side panels. Refer to TM 9-2320-209-10.

b. Removal.

FRAME 1

1. Using 1/2-inch wrenches, unscrew and take off nut (1). Push out accelerator linkage (2).
2. Using 3/4-inch wrench, unscrew locknut (3) from bolt (4). Hold bolt using 15/16-inch wrench. Take off washer (5) and resilient mount (6).
3. Using bronze hammer, tap bolt (4) up through engine mounting bracket (7). Take out bolt and washer (8).

GO TO FRAME 2

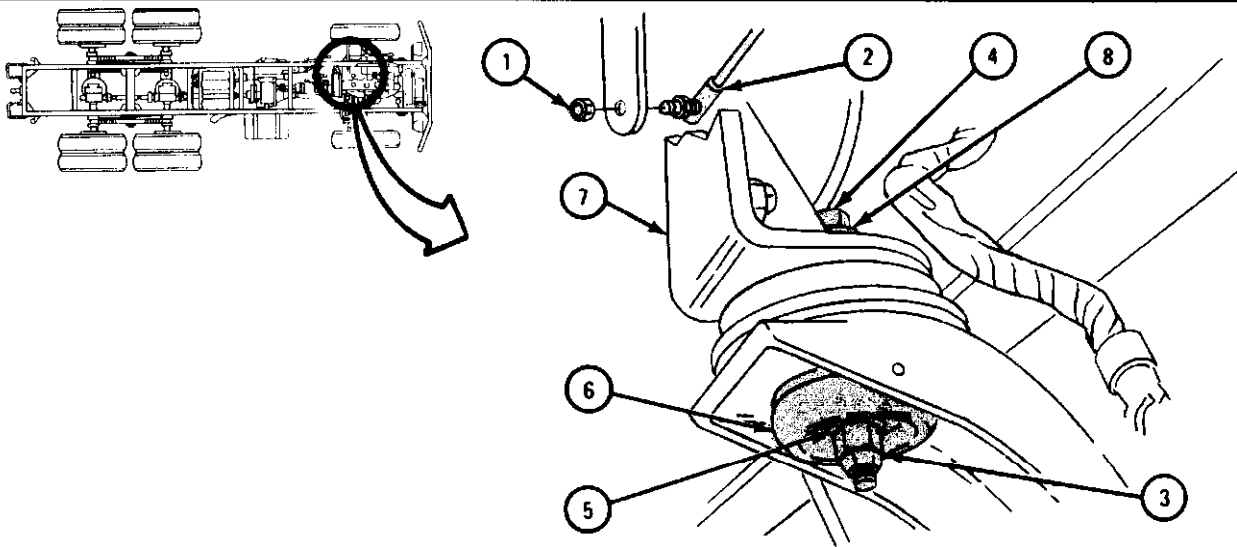

TA 047283

FRAME 2

WARNING

Do not put fingers between rear mounting support (1) and bracket (2). Jack may slip, causing severe injury to personnel.

1. Place jack (3) on large block of wood and put a block of wood between top of jack and jack point (4).
2. Place jack (3) under transmission jack point (4) as shown.
3. Using jack (3) carefully raise rear of engine just enough to push out upper resilient mount (5).
4. Using screwdriver, push out upper resilient mount (5).

END OF TASK

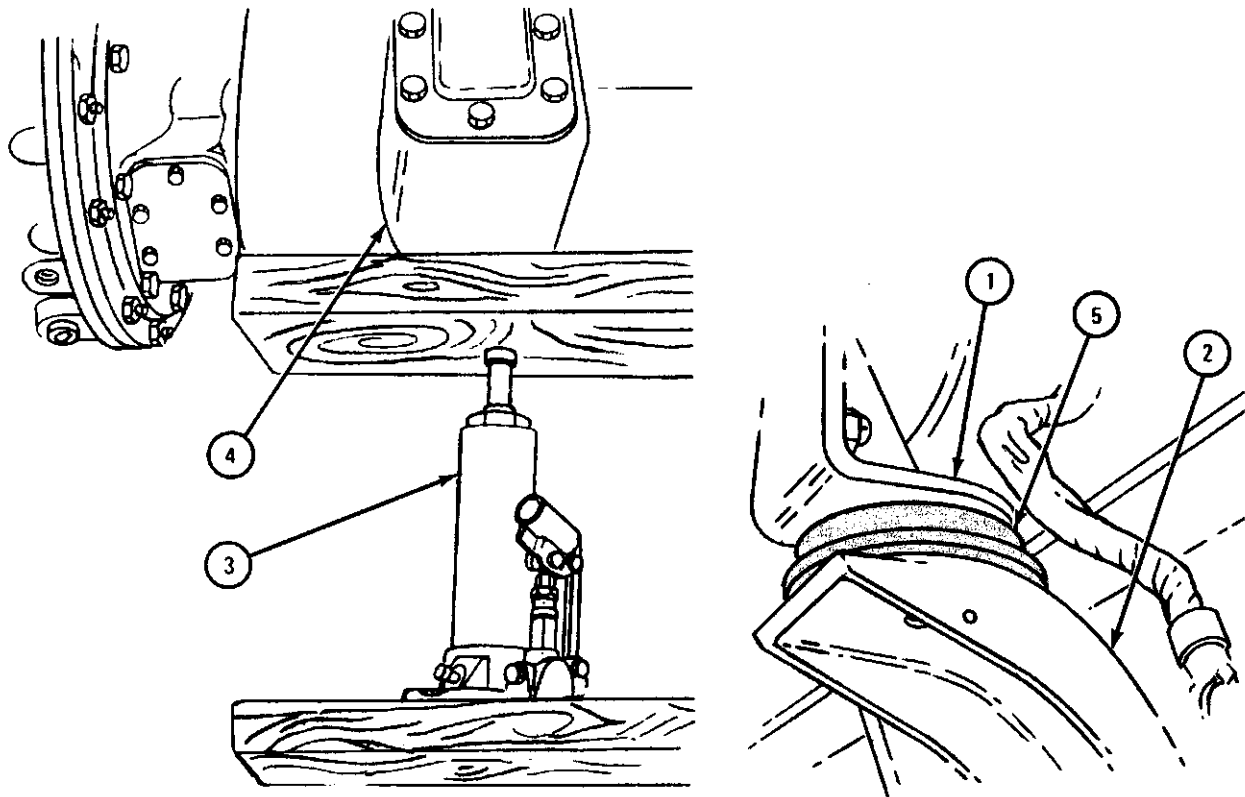

TA 047284

c. Replacement.

FRAME 1

WARNING

Do not put fingers between rear mounting support (1) and bracket (2). Jack may slip, causing severe injury to personnel.

1. Put upper resilient mount (3) between rear mounting support (1) and bracket (2) and align holes.
2. Using jack, carefully lower rear of engine.
3. Put flat washer and bolt (4) through rear mounting support (1), upper resilient mount (3), and bracket (2) as shown.
4. Put lower resilient mount (5) and flat washer (6) on bolt (4). Using 15/16-inch and 3/4-inch wrenches, screw on and tighten locknut (7).
5. Put accelerator linkage (8) through hole in bracket (9). Using 1/2-inch wrenches, screw on and tighten nut (10).

NOTE

Follow-on Maintenance Action Required:

Close hood and both side panels. Refer to TM 9-2320-209-10.

END OF TASK

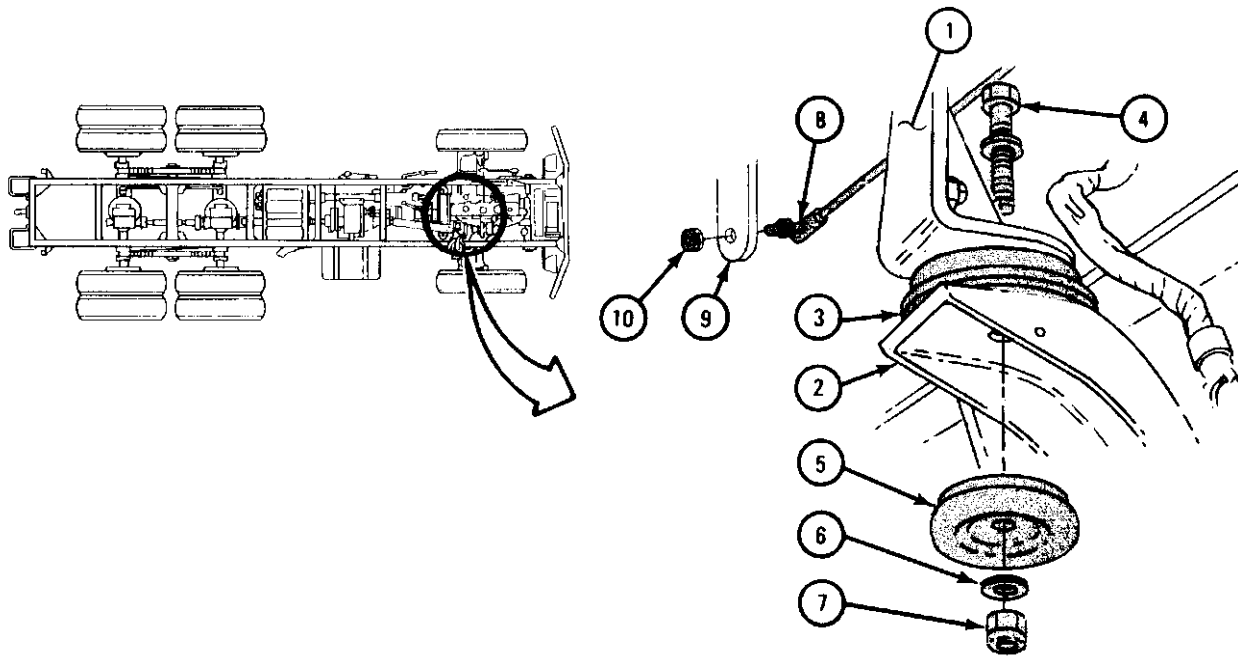

TA 047285

Section III. ENGINE LUBRICATION SYSTEM

2-5. OIL FILTER ELEMENT REMOVAL AND REPLACEMENT.

NOTE

The following tasks are the same for both oil filters.

TOOLS : 7/16-inch open end wrench Drain pan
 7/8-inch wrench 7/8-inch socket
 Torque wrench, 150 pound-feet capacity 6-inch long round nose pliers

SUPPLIES : Oil filter kit, NSN 2940-00-884-4801
 Lubricating oil, ICE, OE/HDO 10, MIL-L-2104

PERSONNEL : One

EQUIPMENT CONDITION : Truck parked, engine off, handbrake set.

Preliminary Procedure. Open hood and left side panel. Refer to TM 9-2320-209-10.

b. Removal.

FRAME 1

1. Place drain pan under engine to catch oil from oil fitting drain plug (1).
2. Using 7/16-inch wrench, unscrew and take out drain plug (1) and wait until oil stops draining.
3. Check drained oil for water, dirt or pieces of metal. If any of these are found, tell direct support maintenance.

GO TO FRAME 2

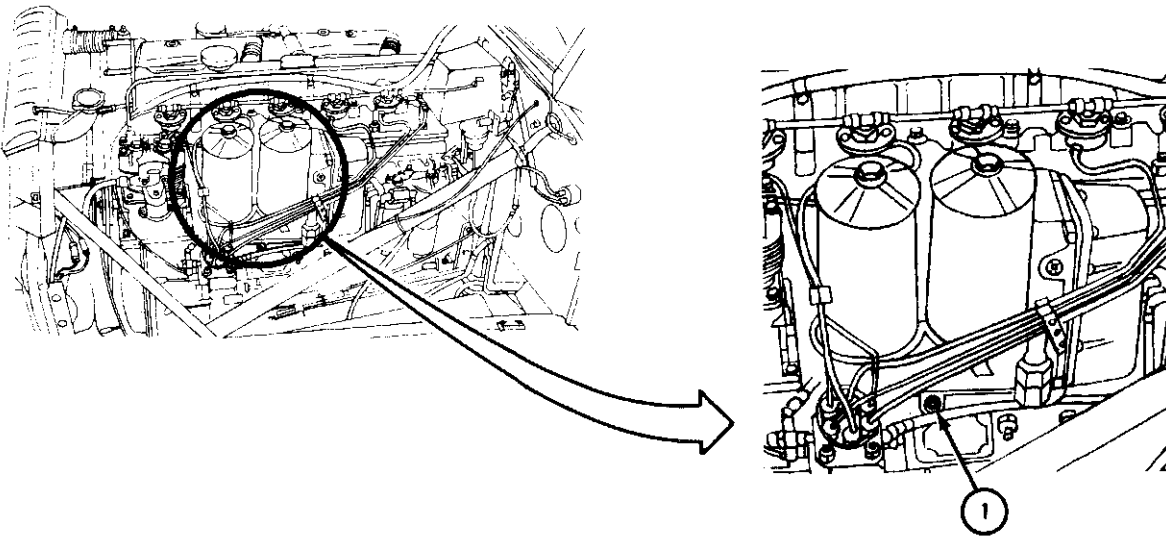

TA 047001

FRAME 2

1. Using 7/8-inch wrench, loosen center post (1) and unscrew center post from base (2).
2. Lift filter assembly (3) from base (2).

GO TO FRAME 3

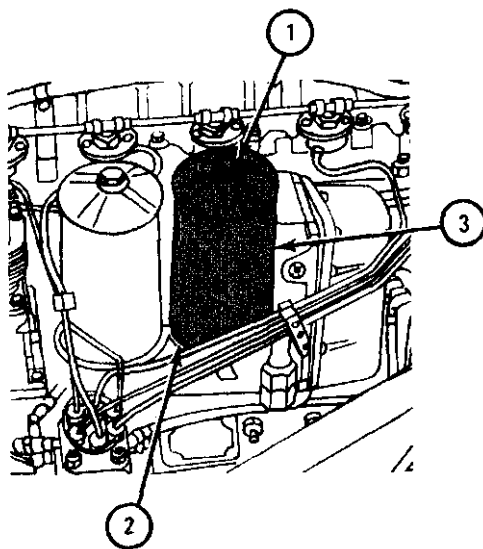

TA 047002

FRAME 3

1. Using pliers, pull out and throw away cotter pin (1).
2. Pull centermost (2) out of body (3).
3. Slide small gasket (4) off post (2) and throw gasket away.
4. Take large gasket (5) off bottom of filter element (6) .

NOTE

Large gasket (5) may stick in filter base on engine.

5. Take cup (7) and spring (8) out of filter element (6) .
6. Throw away large gasket (5) and filter element (6) .

END OF TASK

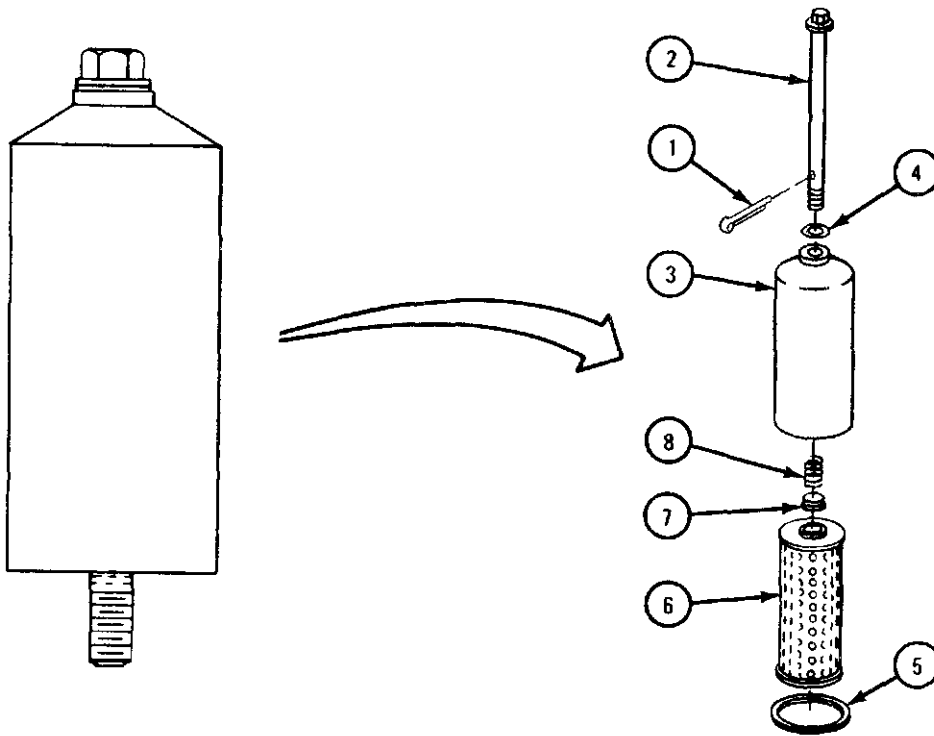

TA 047003

FRAME 1

NOTE

Make sure all surfaces to which gaskets mate are clean.
Coat both gaskets with a thin coat of engine oil before putting them back.

1. Check oil filter repair kit for one small gasket, one large gasket, and one filter element.
2. Put small gasket (1) on center post (2) and slide gasket to top end of center post .
3. Put center post (2) through hole at top of filter body (3).
4. Put spring (4) in cup (5) and set cup into recessed hole at top end of filter element (6). Be sure cup is properly seated in filter element.
5. Put threaded end of center post (2) through assembled spring (4) , cup (5), and filter element (6) .
6. Slide filter element (6) up center post (2) into filter body (3) until it seats against top of filter body. Large gasket (7) will be used when the filter assembly is put back on engine.
7. Put in cotter pin (8) and bend open ends.

GO TO FRAME 2

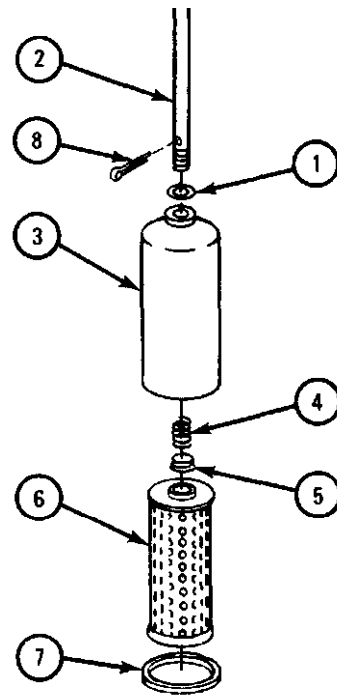
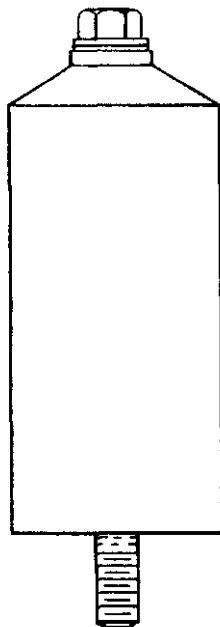

TA 047004

FRAME 2

1. Make sure that inside of base (1) and large gasket (2) are clean. Put large gasket in base.
2. Place filter assembly (3) over base (1) so that threaded end of center post (4) goes into hole. Make sure large gasket (2) is centered.
3. Hand tighten center post (4).
4. Using torque wrench, tighten center post (4) to 60 pound-feet.

GO TO FRAME 3

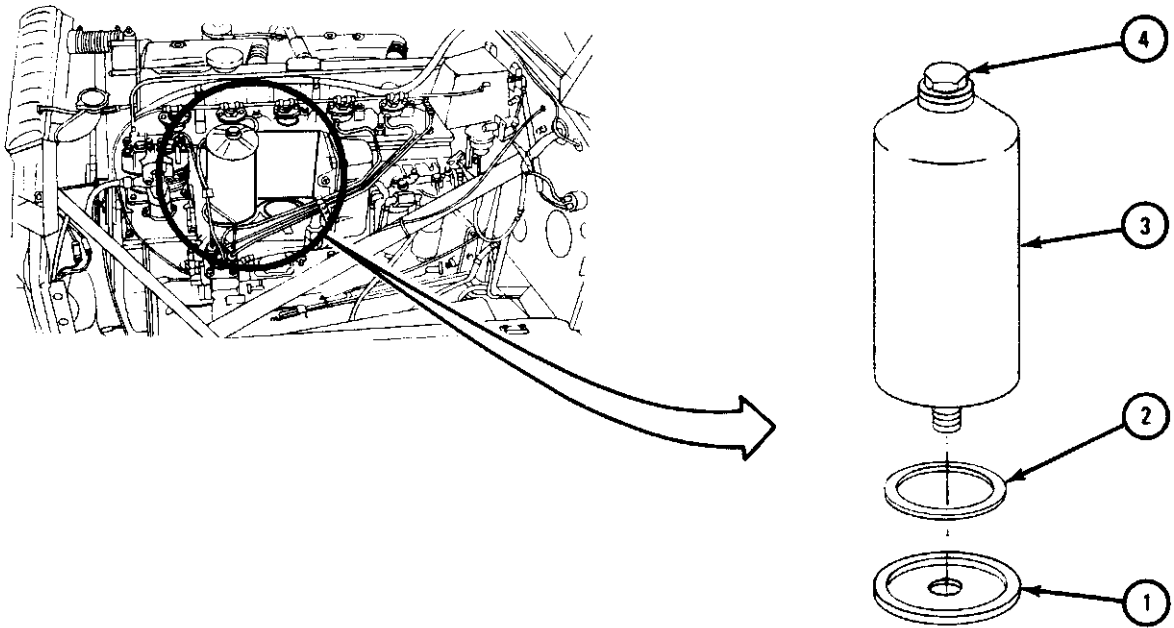

TA 047005

FRAME 3

1. Using 7/16-inch wrench, screw in and tighten drain plug (1) in place.
2. Add engine oil to proper level. Refer to LO 9-2320-209-12/1.
3. Start engine. Refer to TM 9-2320-209-10.
4. Run engine at normal engine temperature and check oil filter (2) for leaks at top and bottom.

NOTE

Follow-on Maintenance Action Required:

Close hood and left side panel. Refer to TM 9-2320-209-10.

END OF TASK

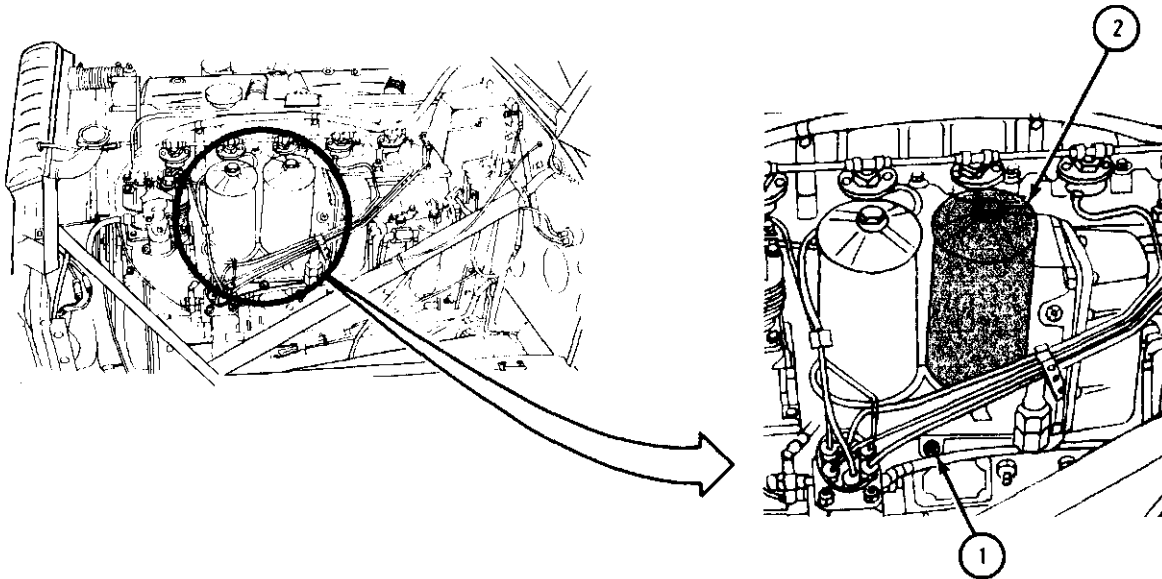

TA 087559

2-6. CRANKCASE BREATHER TUBE REMOVAL AND REPLACEMENT.

- TOOLS :
- | | |
|---|-----------------------------|
| 7/16-inch combination box and open end box wrench | 6-inch extension |
| 3/4-inch combination box and open end box wrench | Ratchet |
| 7/16-inch open end wrench (2) | Flat-tip screwdriver |
| 3/4-inch open end wrench | 5/8-inch open end wrench |
| 9/16-inch socket wrench | 1 3/16-inch open end wrench |
| | 3/8-inch open end wrench |

SUPPLIES : None

PERSONNEL: One

EQUIPMENT CONDITION : Truck parked, engine off and cool, handbrake set.

Preliminary Procedure. Open hood and right side panel. Refer to TM 9-2320-209-10.

b. Removal.

- (1) Breather tube (trucks with engines LD 465-1 and LD 465-1C) .

FRAME 1

1. Using 5/8-inch open end wrench and 3/4-inch combination box and open end box wrench, hold adapter fitting (1) and unscrew and take off tube nut (2) . Unscrew and take off adapter fitting.
 2. Using 7/16-inch wrenches, unscrew and take off capscrew (3) and nut (4) . Spread open and take off clamp (5) .
 3. Using screwdriver, loosen two hose clamps (6) . Pull off hose (7) with crankcase breather tube (8) from breather tube adapter (9) .
 4. Take off two hose clamps (6) and hose (7) from crankcase breather tube (8) .
- END OF TASK

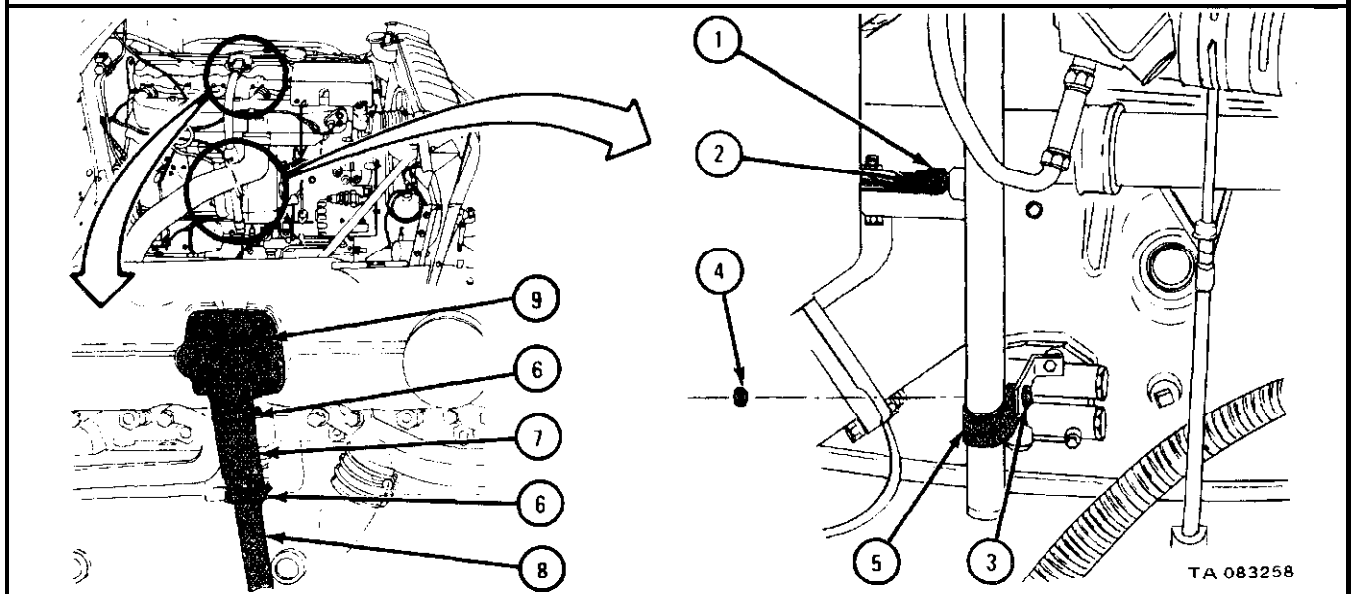

(2) Breather tube (trucks with engine LDS 427-2).

FRAME 1

1. Working under hood using 7/16-inch wrenches, unscrew and take off capscrew (1) and nut (2). Spread open and take off clamp (3).
2. Using 3/8-inch wrench and 7/16-inch combination box and open end box wrench, hold adapter fitting (4) and unscrew and take off tube nut (5).
3. Using 7/16-inch wrench, unscrew and take off adapter fitting (4).
4. Using 5/8-inch open end wrench, unscrew and take off tube nut (6).
5. Using 13/16-inch wrench, unscrew and take off adapter fitting (7).

GO TO FRAME 2

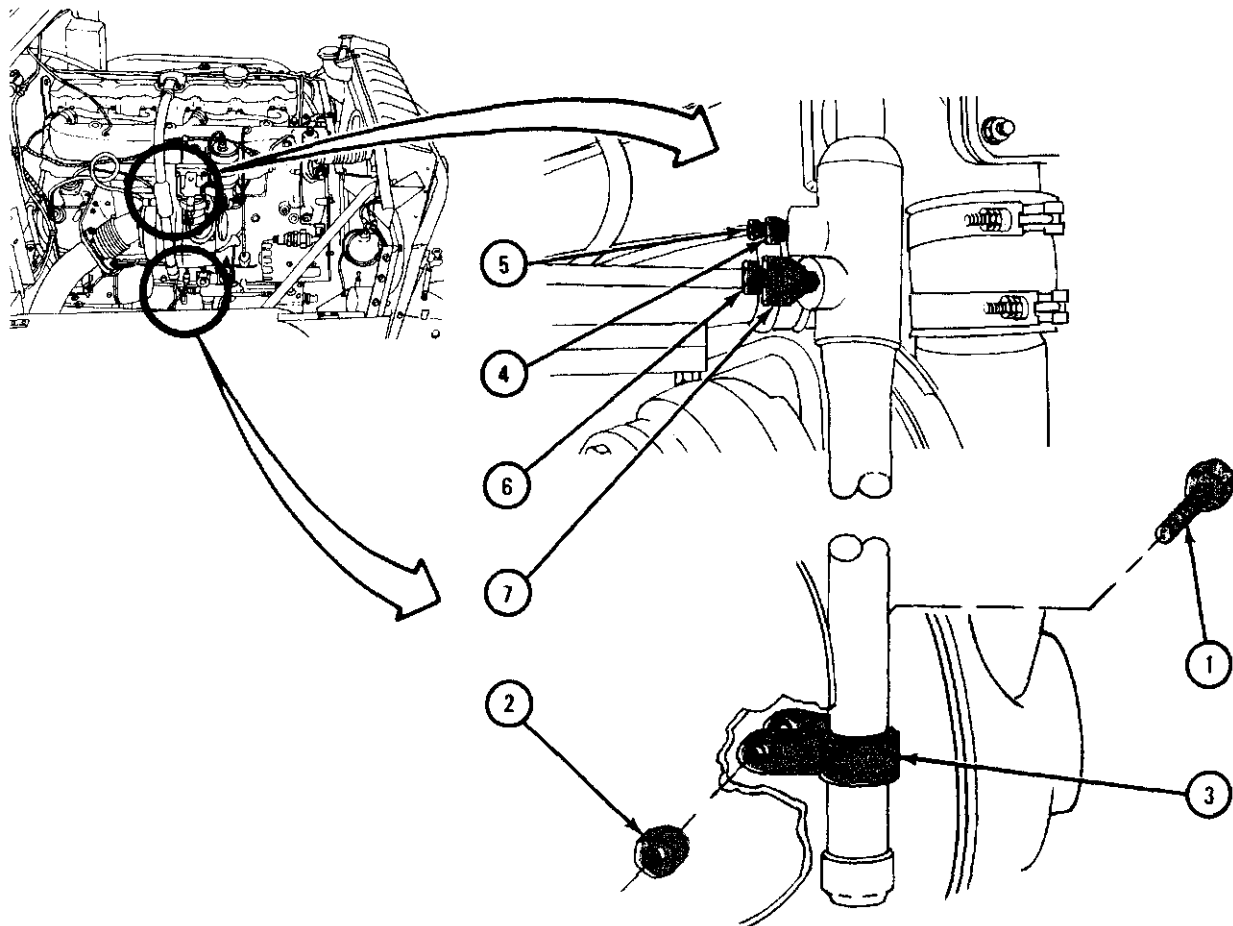

TA 084087

FRAME 2

1. Using screwdriver, loosen two hose clamps (1). Take hose (2) and crankcase breather tube (3) off breather tube adapter (4).
2. Take two hose clamps (1) and hose (2) off crankcase breather tube (3).

END OF TASK

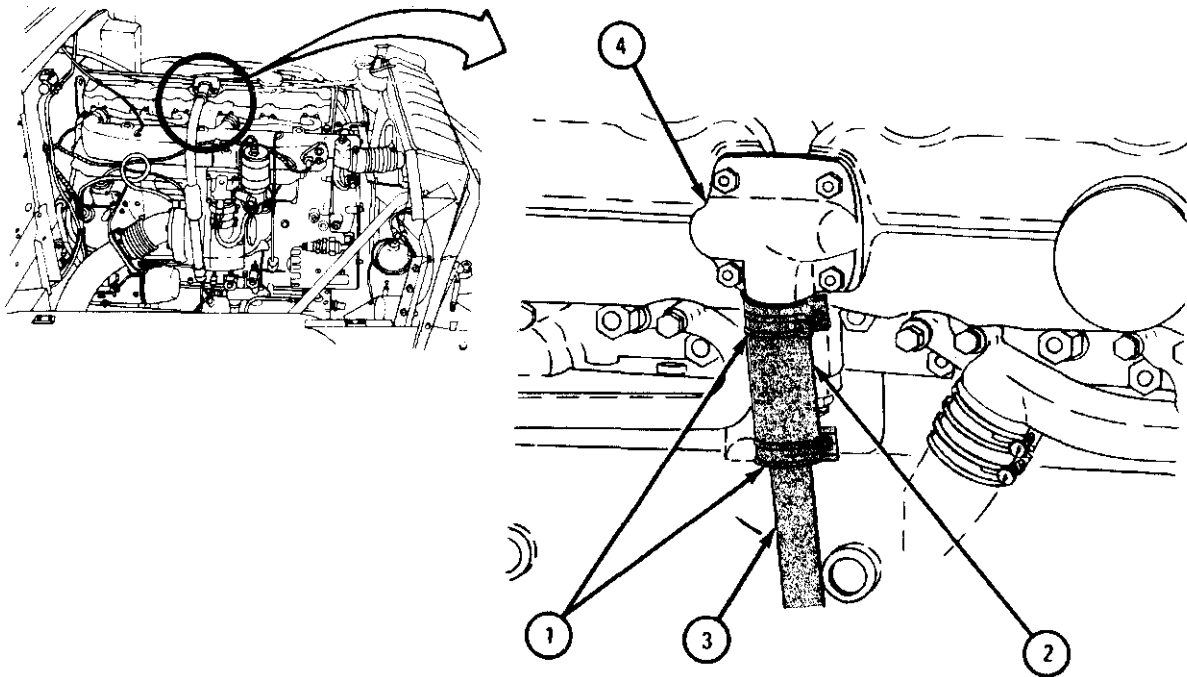

TA 084088

(3) Breather tube (trucks with engine LDT 427-2).

FRAME 1

1. Working under truck using ratchet, extension, and 9/16-inch socket wrench, unscrew and take out capscrew and washer (1).
2. Working under hood using 5/8-inch open end wrench and 3/4-inch wrench, hold adapter fitting (2) and unscrew and take off tube nut (3).
3. Using 3/4-inch wrench, unscrew and take off adapter fitting (2).

GO TO FRAME 2

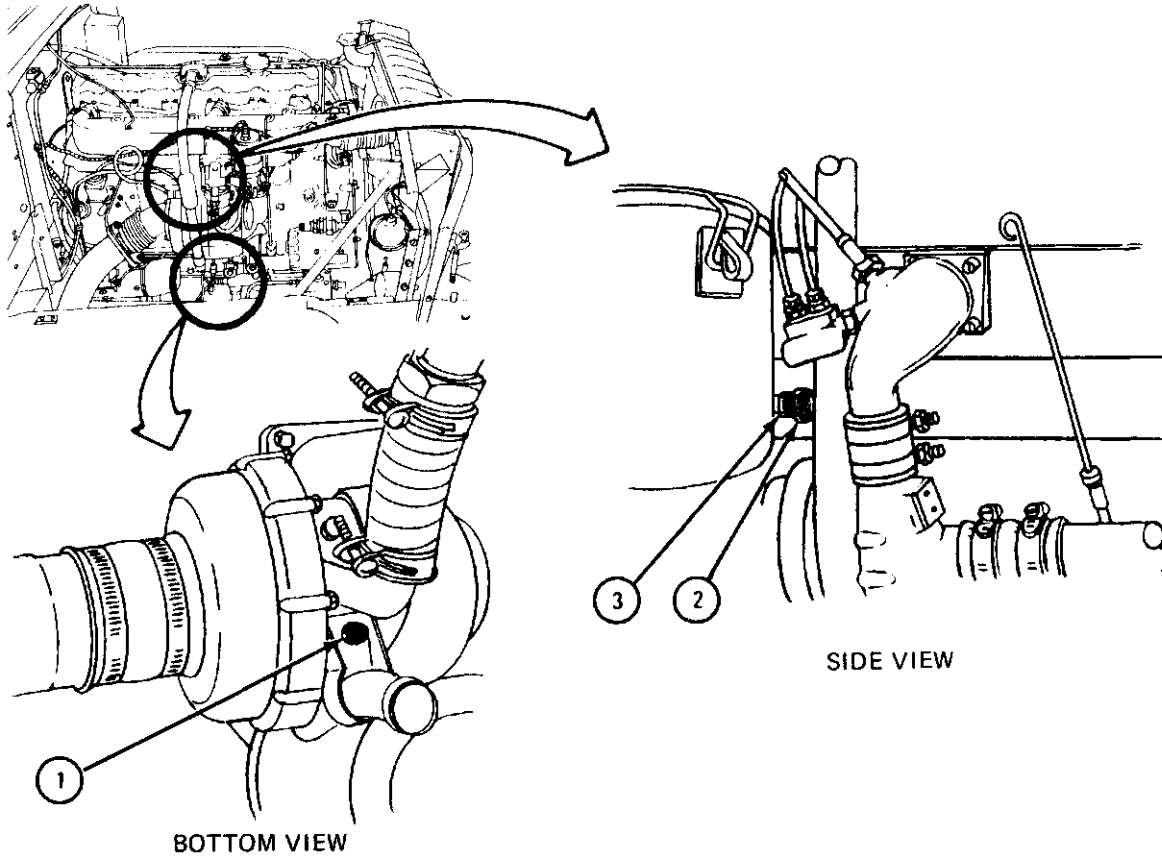

TA 084091

FRAME 2

1. Working under hood using screwdriver, loosen two hose clamps (1).
2. Take crankcase breather tube (2) and hose (3) off breather tube adapter (4). Take off hose and two hose clamps (1) from crankcase breather tube.

END OF TASK

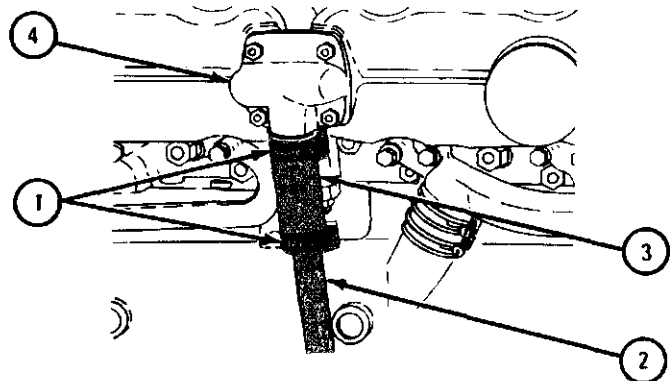
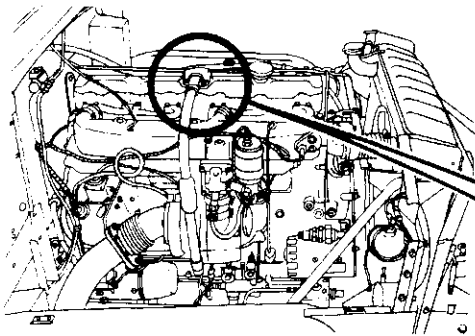

TA 089474

c. Replacement.

(1) Breather tube (trucks with engines LD 465-1 and LD 465-1C).

FRAME 1

1. Put hose (1) on breather tube adapter (2). Slide two hose clamps (3) on hose.
2. Put crankcase breather tube (4) in hose (1). Using screwdriver, tighten two hose clamps (3) in place as shown.
3. Put clamp (5) over crankcase breather tube (4) and align screw hole in clamp with screw hole in bracket (6).
4. Using 7/16-inch wrenches, screw on and tighten capscrew (7) and nut (8).
5. Using 3/4-inch combination box and open end box wrench, screw in and tighten adapter fitting (9).
6. Using 5/8-inch open end wrench, screw in and tighten tube nut (10).

NOTE

Follow-on Maintenance Action Required:

Close hood and right side panel. Refer to TM 9-2320-209-10.

END OF TASK

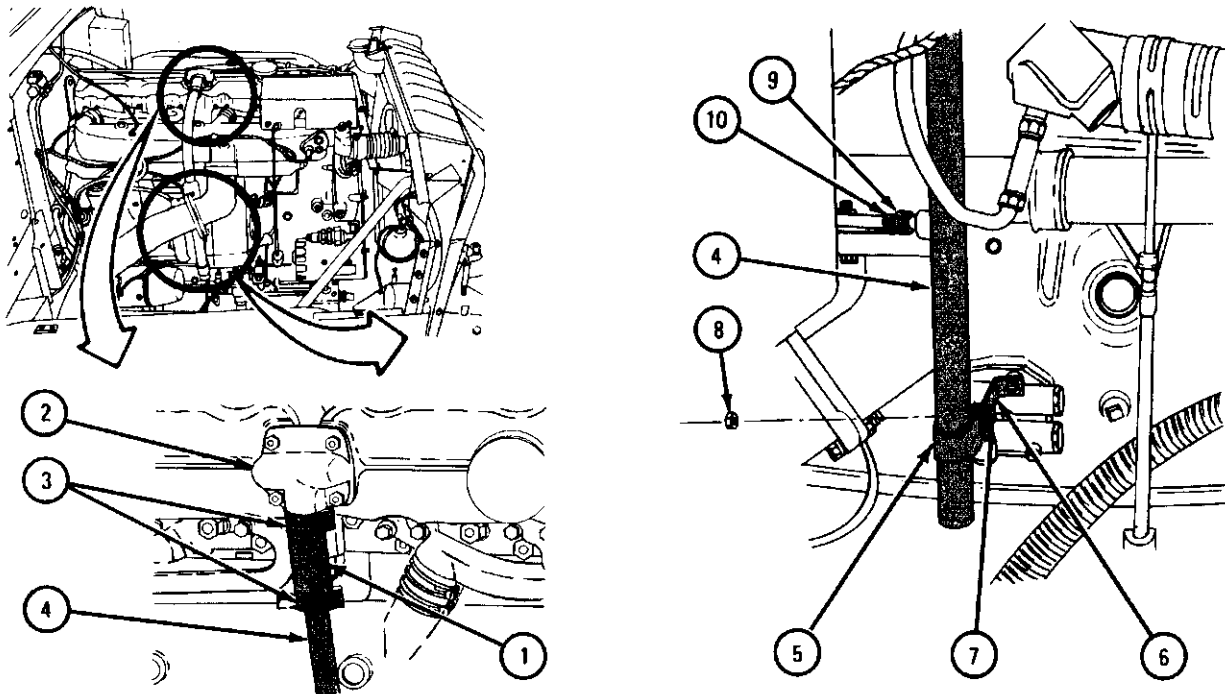

TA 083259

(2) Breather tube (trucks with engine LDS 427-2).

FRAME 1

1. Put hose (1) on breather tube adapter (2). Slide two hose clamps (3) on hose.
2. Put crankcase breather tube (4) into hose (1). Using screwdriver, tighten two hose clamps (3) in place as shown.

GO TO FRAME 2

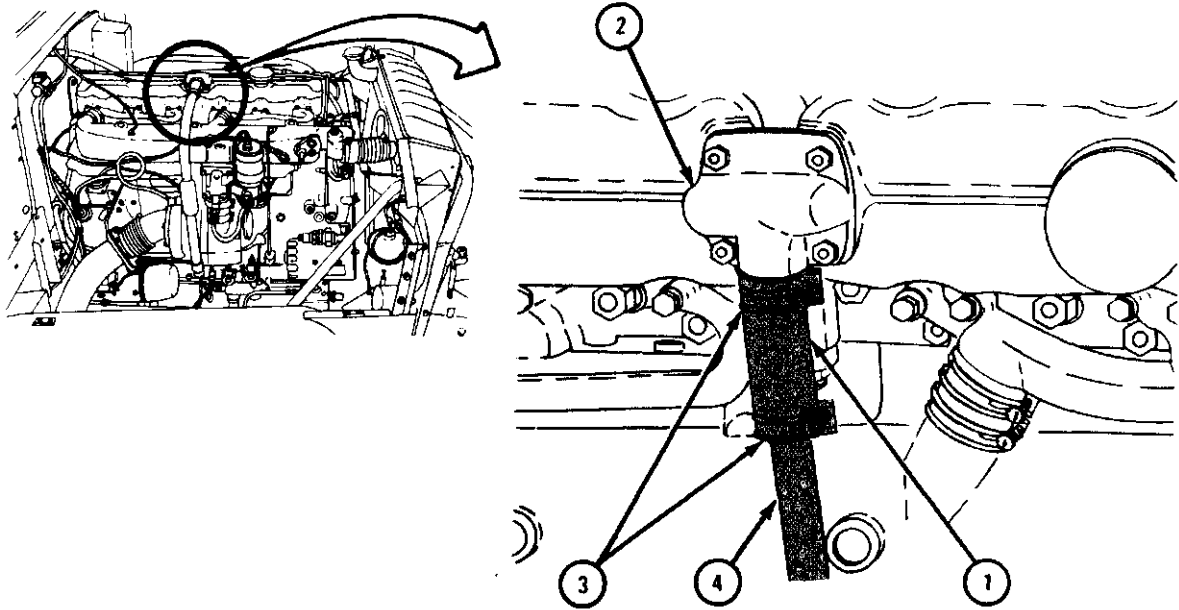

TA 084089

FRAME 2

1. Working under hood, put clamp (1) on crankcase breather tube (2) as shown. Aline screw hole in clamp with screw hole in bracket (3).
2. Using 7/16-inch wrenches, screw on and tighten capscrew (4) and nut (5).
3. Using 7/16-inch wrench, screw in and tighten adapter fitting (6).
4. Using 3/8-inch open end wrench, screw in and tighten tube nut (7).
5. Using 13/16-inch wrench, screw in and tighten adapter fitting (8).
6. Using 5/8-inch open end wrench, screw in and tighten tube nut (9).

NOTE

Follow-on Maintenance Action Required:

Close hood and right side panel. Refer to TM 9-2320-209-10.

END OF TASK

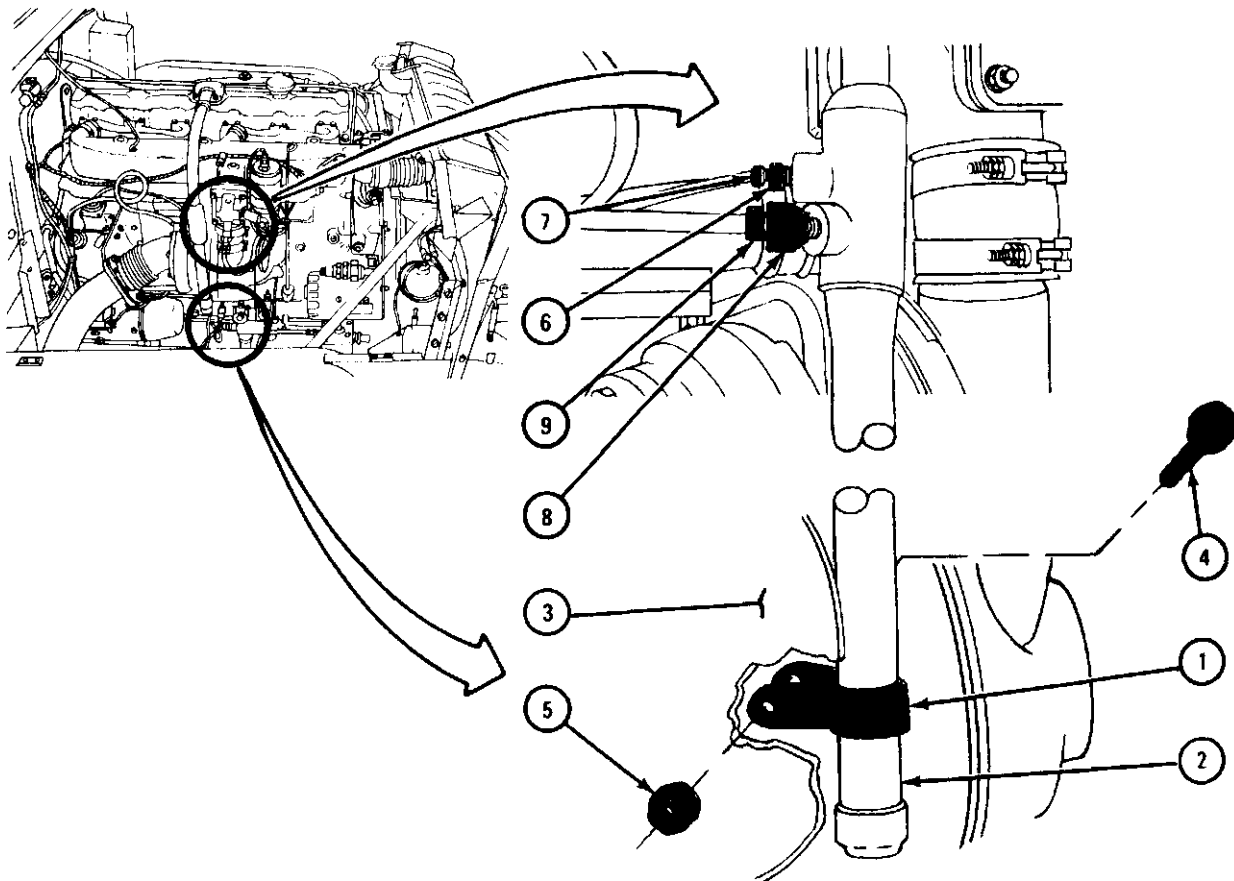

TA 084090

(3) Breather tube (trucks with engine LDT 427-2).

FRAME 1

1. Working under hood, put hose (1) on breather tube adapter (2). Slide two hose clamps (3) on hose.
2. Put crankcase breather tube (4) into hose (1). Using screwdriver, tighten two hose clamps (3) in place as shown.

GO TO FRAME 2

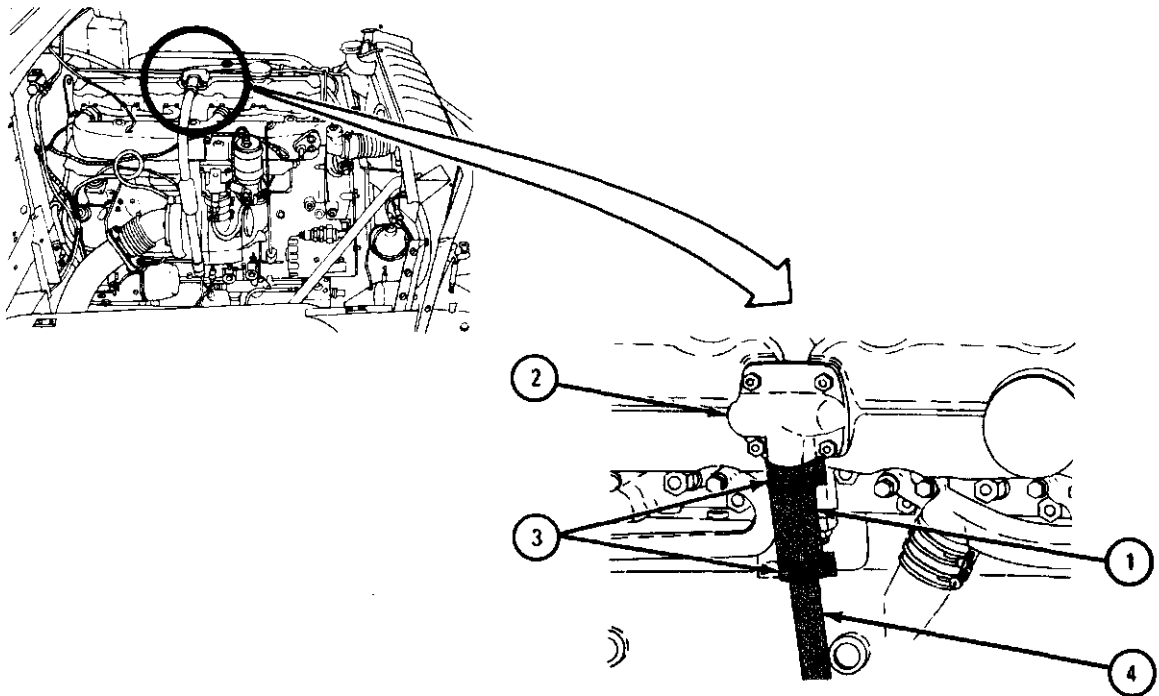

TA 084092

FRAME 2

1. Working under truck using ratchet, extension, and 9/16-inch socket wrench, screw in and tighten capscrew and washer (1).
2. Working under hood using 3/4-inch wrench, screw in and tighten adapter fitting (2) .
3. Using 5/8-inch open end wrench, screw in and tighten tube nut (3) .

NOTE

Follow-on Maintenance Action Required:

Close hood and right side panel. Refer to TM 9-2320-209-10.

END OF TASK

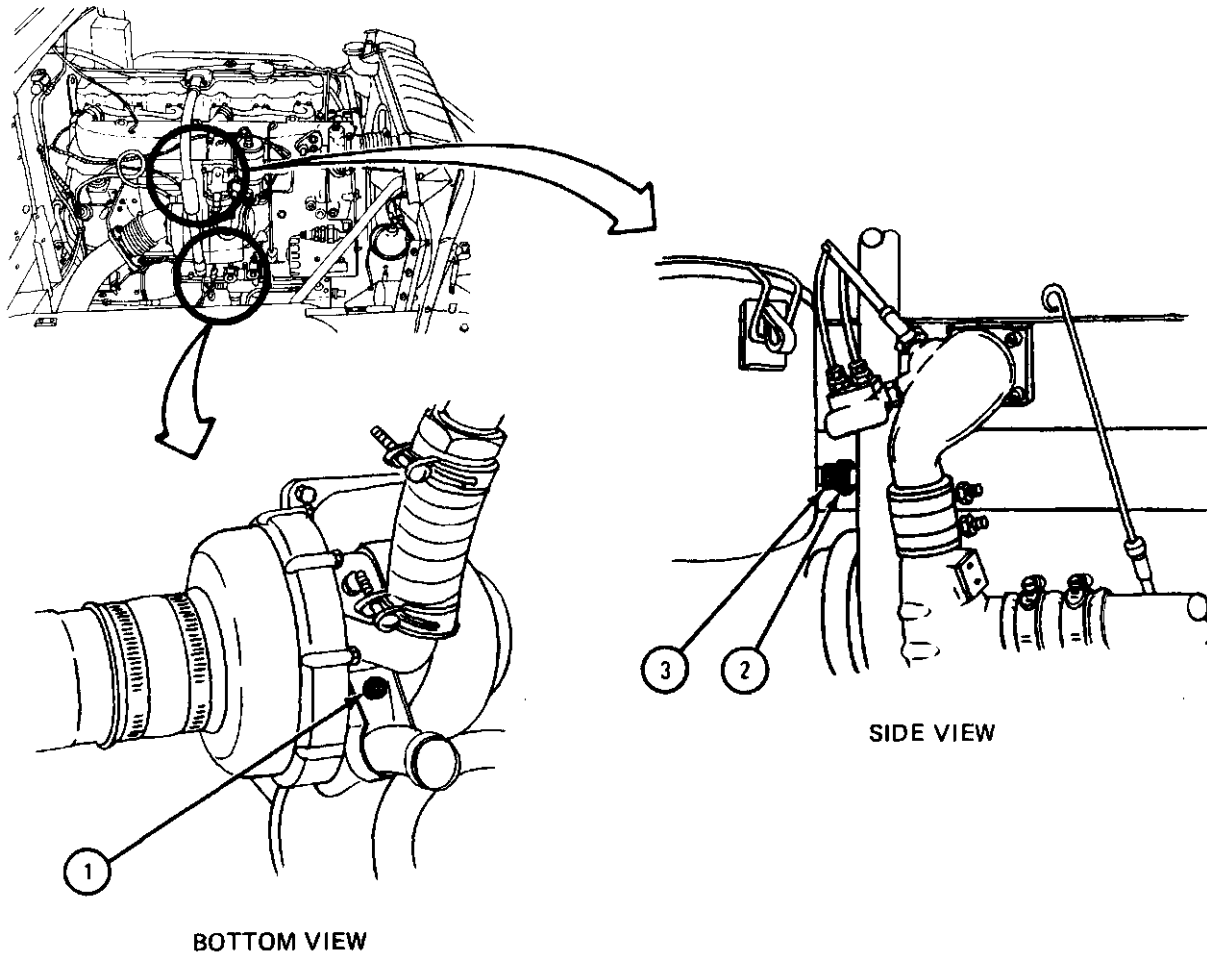

TA 089475

CHAPTER 3

CLUTCH SYSTEM GROUP MAINTENANCE

Section I. SCOPE

3-1. EQUIPMENT ITEMS COVERED. This chapter gives equipment maintenance procedures for the clutch linkage assembly for which there are authorized corrective maintenance tasks at the organizational maintenance level.

3-2. EQUIPMENT ITEMS NOT COVERED . All equipment items for which corrective maintenance is authorized at the organizational maintenance level are covered in this chapter.

Section II. CLUTCH LINKAGE ASSEMBLY

3-3. CLUTCH CONTROL AND LINKAGE REMOVAL , REPAIR, REPLACEMENT, AND ADJUSTMENT .

TOOLS :	Prybar	6-inch ruler
	9/16-inch wrench (2)	Drift pin punch
	3/4-inch wrench (2)	Pliers
	Flat-tip screwdriver	

SUPPLIES : Chalk, SS-C-266F

PERSONNEL : One

EQUIPMENT CONDITION : Truck parked, engine off, handbrake set, wheels chocked.

a. Preliminary Procedures.

(1) Take off accelerator linkage. Refer to para 4-29.

(2) On trucks with transmission power takeoff, tell direct support maintenance to take off power takeoff.

b. Removal.

FRAME 1

1. Using pliers, unhook clutch return spring (1) from clutch control lever (2).
2. Using pliers, unhook brake return spring (3) from brake clevis pin (4).

NOTE

Pedal shaft (6) has height adjustment notches (8).
Before taking out pedal, use chalk to mark which notch is used so it will be put back in same notch.

3. Using 9/16-inch wrench, unscrew and take out bolt (5) and push pedal shaft (6) up through floor into cab. Take away rubber bumper (7).

GO TO FRAME 2

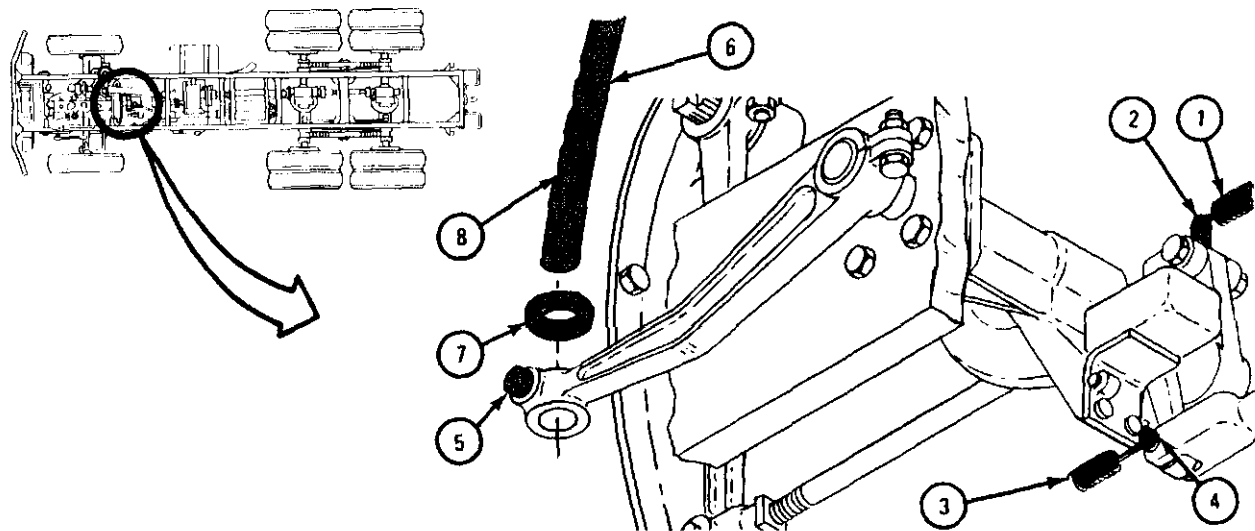

TA 047253

FRAME 2

1. Using 9/16-inch wrenches, loosen locknut (1) while holding bolt (2). Pull pedal lever (3) off end of shaft (4) .
2. Using screwdriver, pry woodruff key (5) out of pedal lever shaft (4).

GO TO FRAME 3

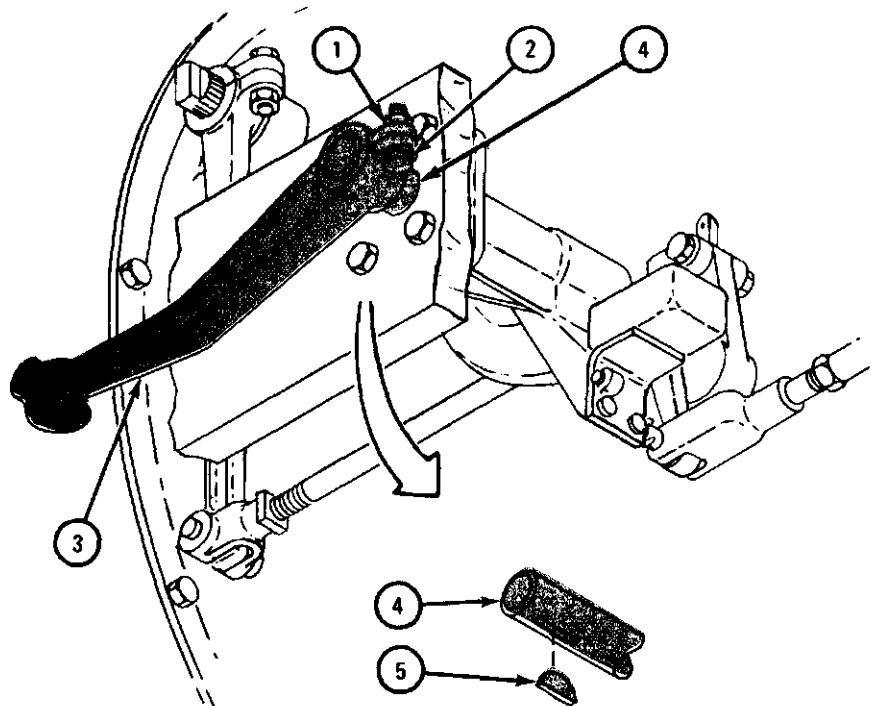

TA 047254

FRAME 3

1. Using 3/4-inch wrenches, unscrew and takeoff locknut (1) and bolt (2). Lift away end of control rod (3).
2. Using 3/4-inch wrenches, loosen locknut (4) while holding bolt (5). Slide clutch throw out lever (6) with control rod (3) off clutch throwout shaft (7).

GO TO FRAME 4

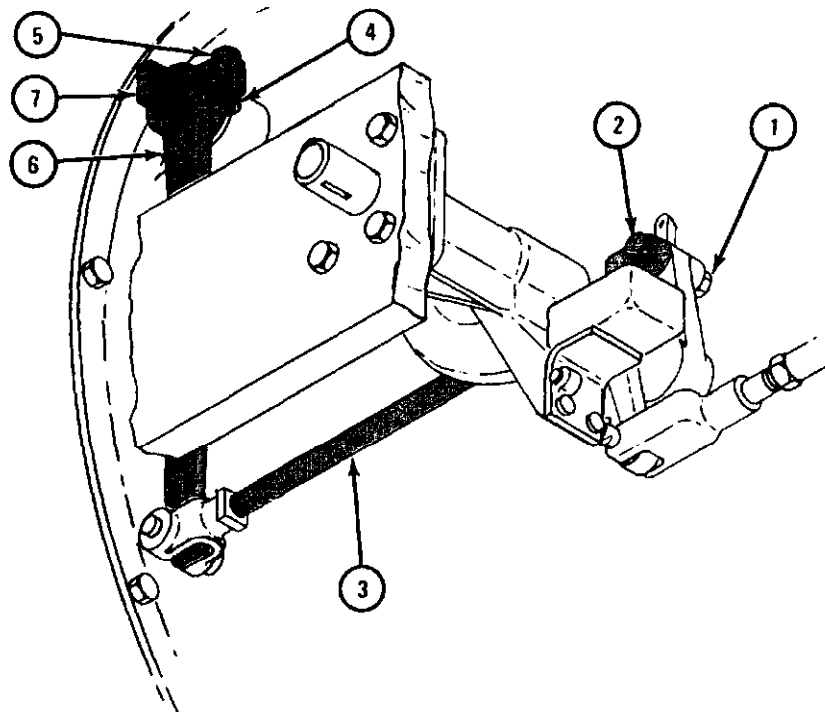

TA 047255

FRAME 4

1. Using 9/16-inch wrenches, loosen locknut (1) while holding bolt (2) . Pull control lever (3) off pedal lever shaft (4) .
2. Using screwdriver, pry woodruff key (5) out of slot in pedal lever shaft (4).
3. Pull pedal lever shaft (4) out of brake lever (6) and shaft support (7).

GO TO FRAME 5

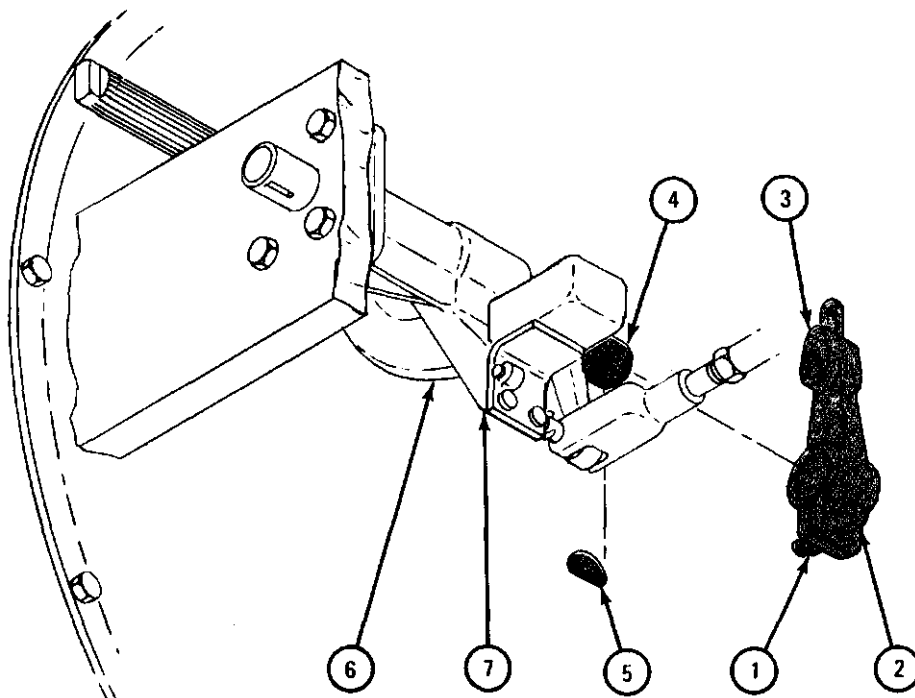

TA 047256

FRAME 5

NOTE

Do not pull spring loaded pin (1) all the way out of clevis (2).

1. Pull pin (1) to one side of clevis (2).
2. Take clutch throwout lever (3) out of clevis (2).
3. Using 3/4-inch wrench, loosen nut (4) on rod (5) and unscrew clevis (2) from rod. Unscrew nut from rod.

END OF TASK

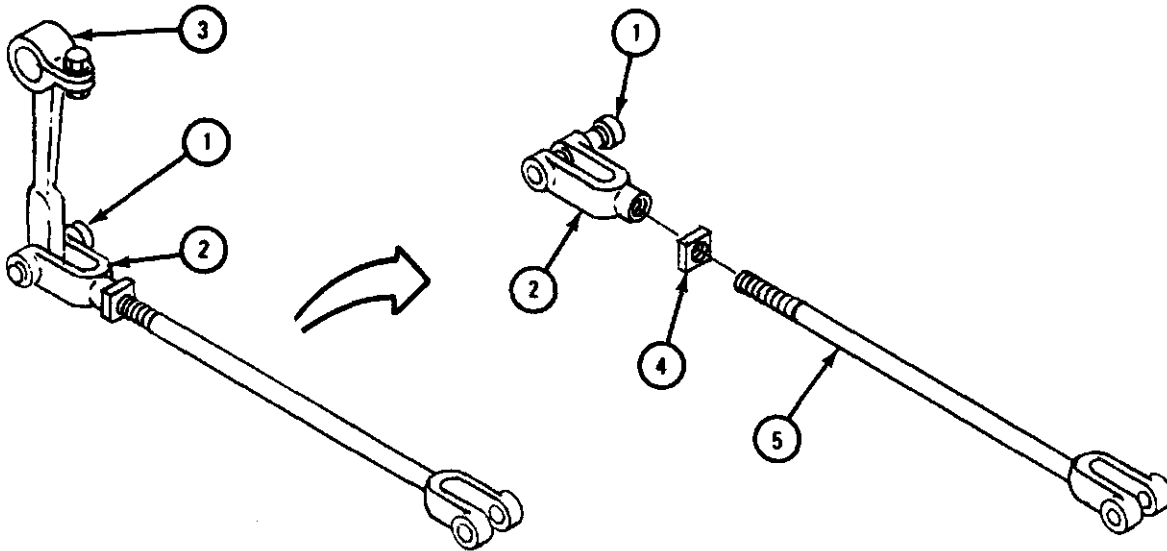

TA 047257

c. Repair. Repair clutch control and linkages by welding, straightening or replacing any broken or damaged parts. Refer to TM 9-237.

d. Replacement.

FRAME 1

1. Put pedal lever shaft (1) through brake lever assembly (2) and then through shaft support (3) as shown.
2. Put woodruff key (4) in slot at end of pedal lever shaft (1).
3. Put control lever (5) on end of pedal lever shaft (1). Pedal lever slot must align with key (4) on shaft. End of control lever should be flush with shaft.
4. Using 9/16-inch wrenches, tighten locknut (6) while holding bolt (7).

GO TO FRAME 2

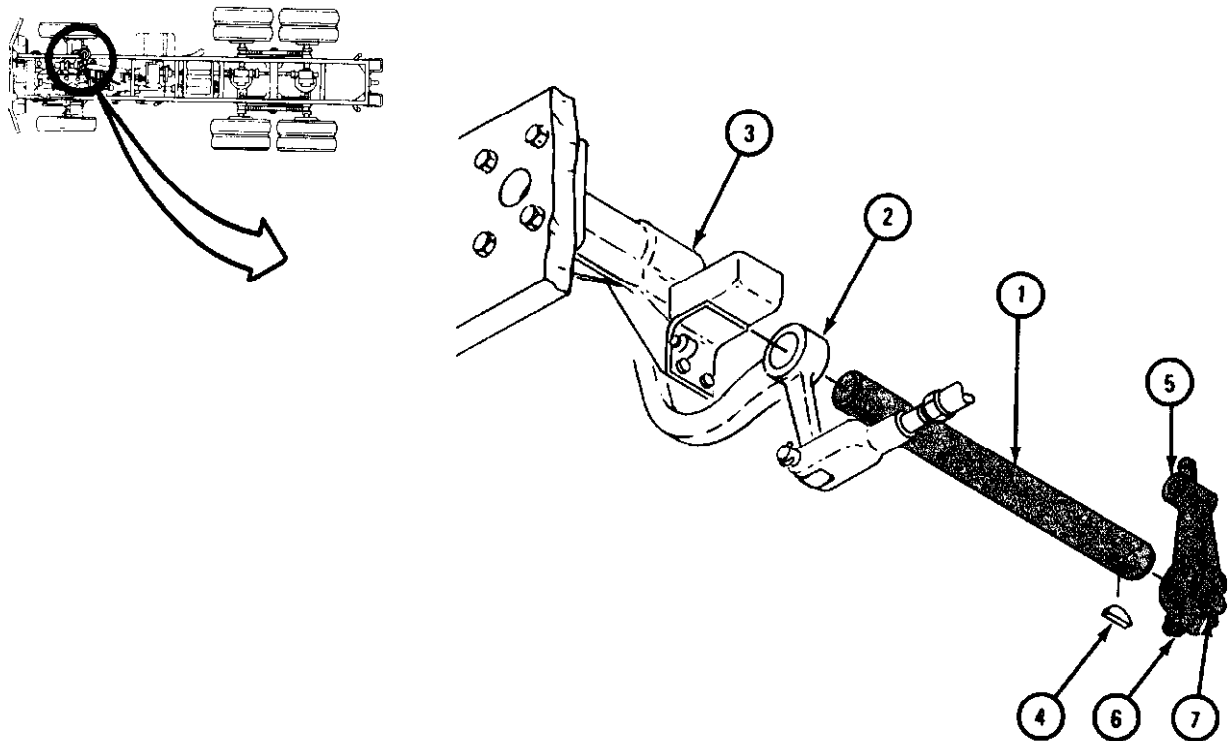

TA 047258

FRAME 2

1. Screw nut (1) onto rod (2) and then screw clevis (3) onto rod.
2. Screw clevis (3) in or out on rod (2) as necessary to set length. Set length between clevis (3) and (4) hole centers to 14 1/8 inches as shown.
3. Using 3/4-inch wrenches, hold clevis (3) and tighten nut (1) .
4. Put clutch throwout shaft lever (5) on clutch throwout shaft (6). Center line must be one spline to rear of shaft center line as shown.

GO TO FRAME 3

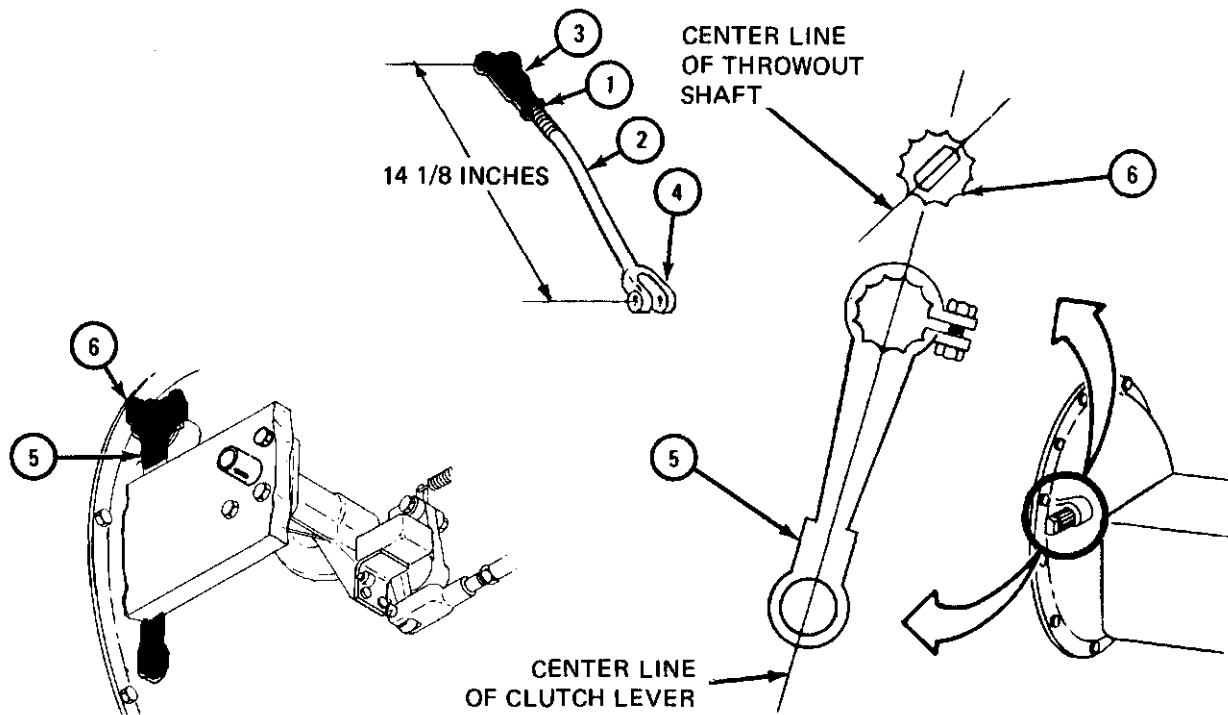

TA 047259

FRAME 3

1. Push lower end of clutch throwout shaft lever (1) forward until resistance is noted. Using scale, measure distance from center of lever bottom hole to transmission flange as shown.

NOTE

Measurement should be approximately 3 1/4 inches.

2. If measurement is not approximately 3 1/4 inches, take off lever (1) and turn it one spline at a time until measurement is correct.
3. Using 3/4-inch wrenches, hold bolt (2) and tighten nut (3) .

NOTE

Before joining rod assembly (4) to control lever (5) , put lever in up position.

4. Join rod assembly (4) to control lever (5) with bolt (6) and locknut (7) . Locknut must be on transmission side as shown.
5. Join rod assembly (4) to clutch throwout shaft lever (1) using pin (8) . Head of pin must be on transmission side as shown. Using prybar, pry pin in clevis (9) until head of pin seats against clevis.
6. Using 3/4-inch wrenches, tighten locknut (7).

Go TO FRAME 4

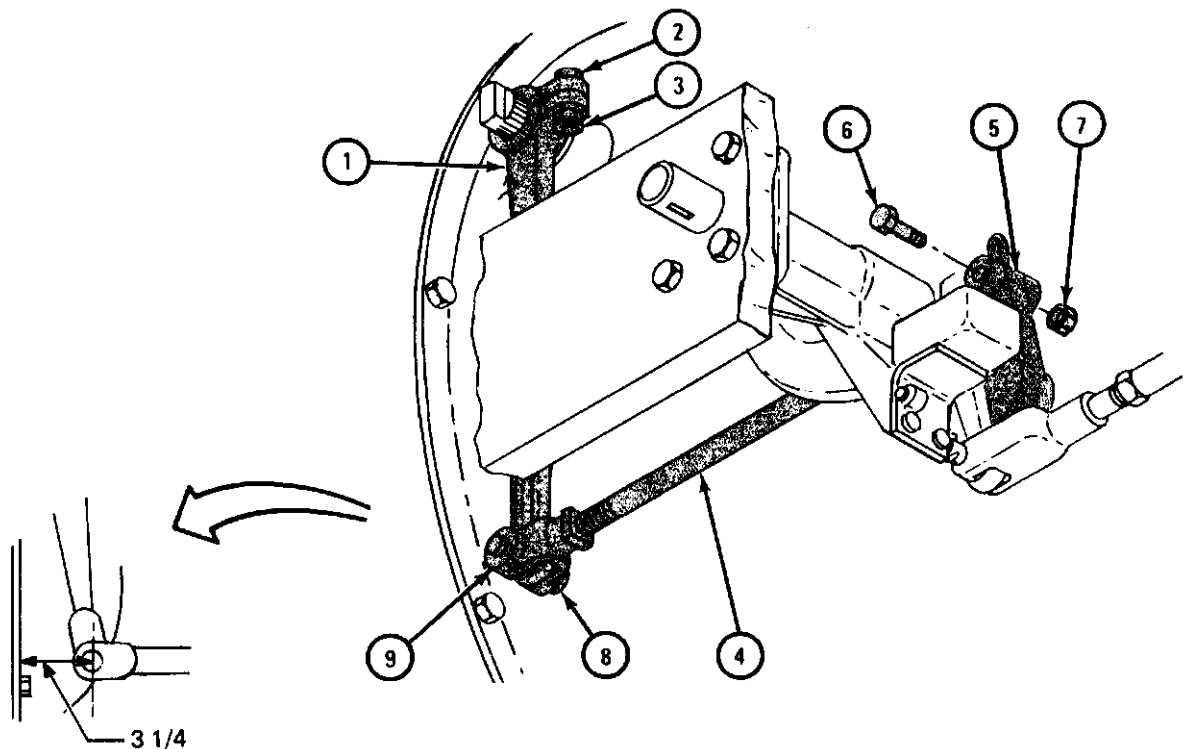

TA 047260

FRAME 4

1. Using pliers, hook clutch return spring (1) to clutch control lever (2).
2. Using pliers, hook brake return spring (3) to clevis pin (4).
3. Put woodruff key (5) in slot in pedal lever shaft (6).

GO TO FRAME 5

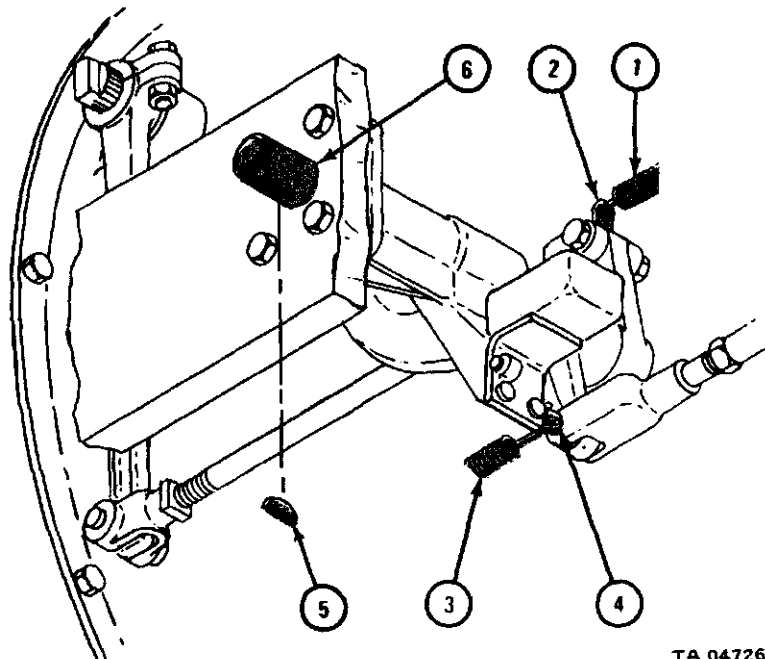

TA 047261

FRAME 5

1. Put pedal lever (1) on end of pedal lever shaft (2). Woodruff key (3) must align with slot in pedal lever.
2. Using 9/16-inch wrenches, tighten locknut (4) while holding bolt (5) .

GO TO FRAME 6

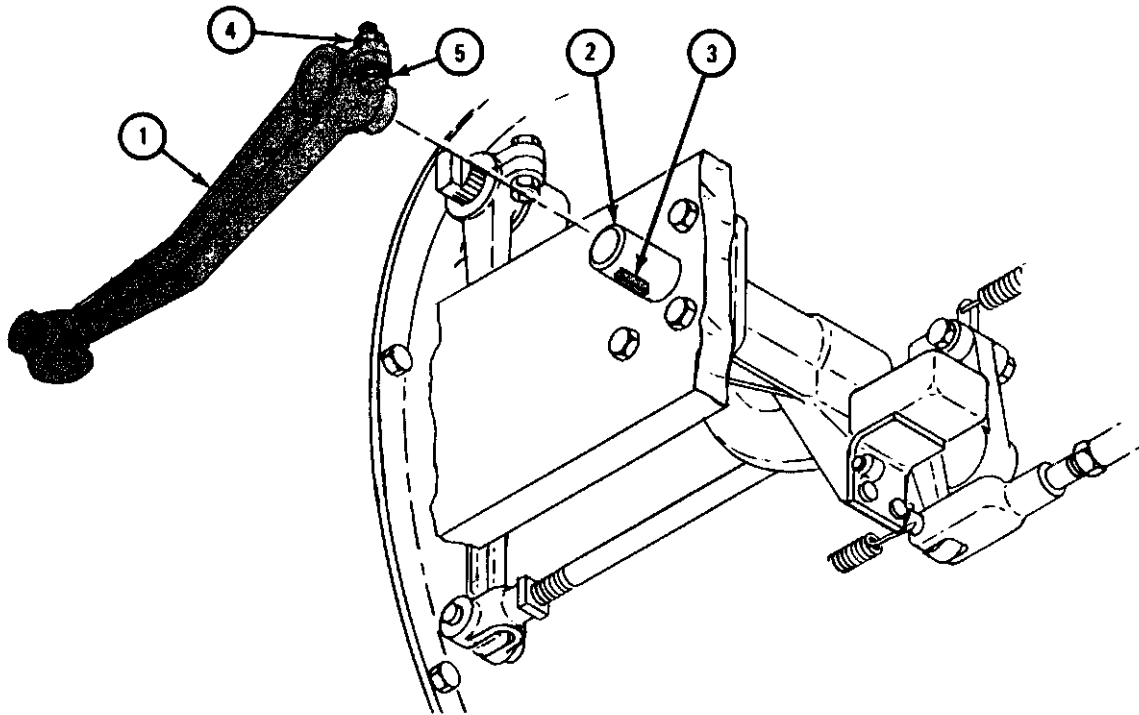

TA 047262

FRAME 6

1. Put pedal (1) through hole in cab floor (2).
- GO TO FRAME 7

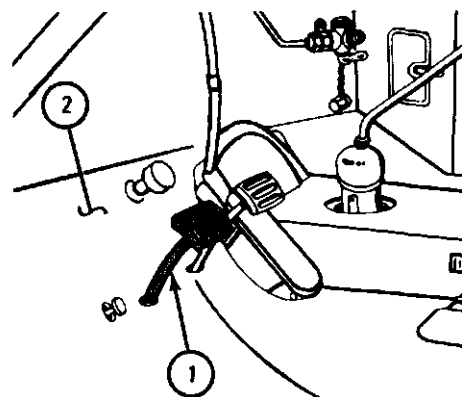
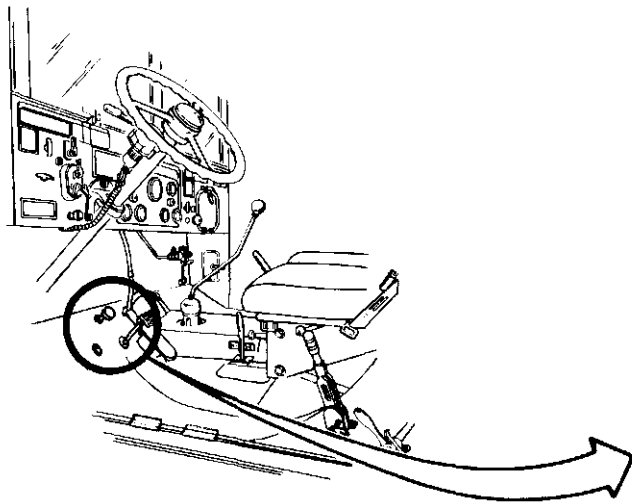

TA 047263

FRAME 7

1. From underneath truck, put rubber bumper (1) on pedal shaft (2).

NOTE

Pedal shaft (2) has height adjustment notches. Set pedal shaft so bolt (3) will be in same notch it was in before taking out pedal.

2. Put pedal shaft (2) through hole in pedal lever (4). Set to right notch and screw in bolt (3). Using 9/16-inch wrench, tighten bolt.

GO TO FRAME 8

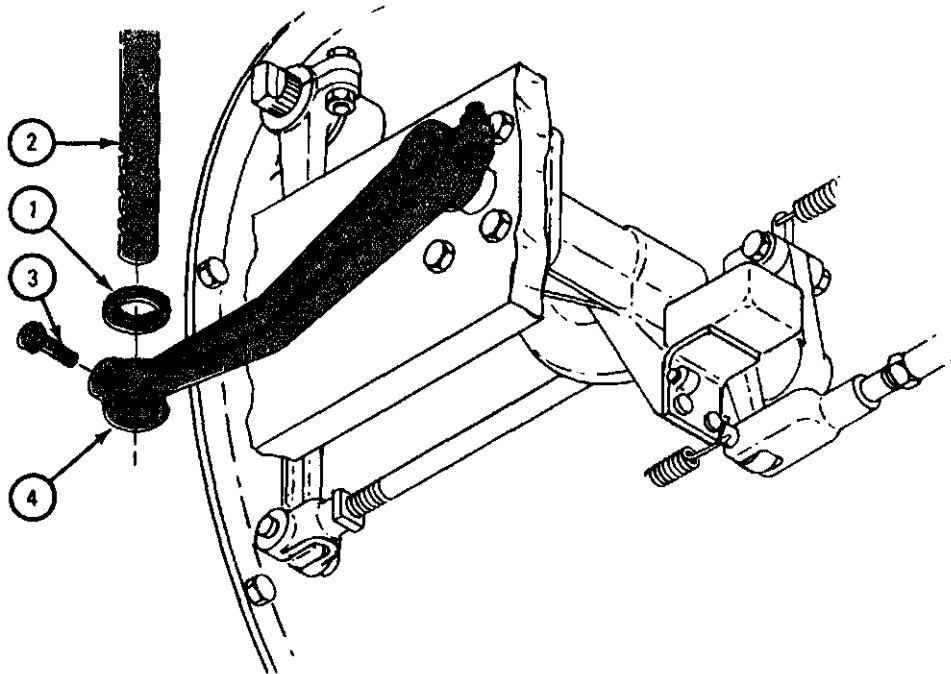

TA 047264

FRAME 8

1. Using chalk, put mark on clutch pedal shaft (1) where shaft meets floor (2).
2. Using hand, push clutch pedal (3) down until resistance is felt. While still holding down pedal, put another chalk mark on pedal shaft (1) where shaft meets floor (2).
3. Let go of pedal (3) and measure distance between two marks (4) using a 6-inch ruler. Distance (free pedal travel) should be 1 1/2 to 2 inches.
4. If free pedal travel is not 1 1/2 to 2 inches, do clutch adjustment procedure. Refer to para 3-3e.

NOTE

Follow-on Maintenance Action Required:

1. Tell direct support maintenance to put- power takeoff on transmission.
2. Fill transmission with fluid. Refer to LO 9-2320-209-12/1.
3. Put on accelerator linkage. Refer to para 4-29.

END OF TASK

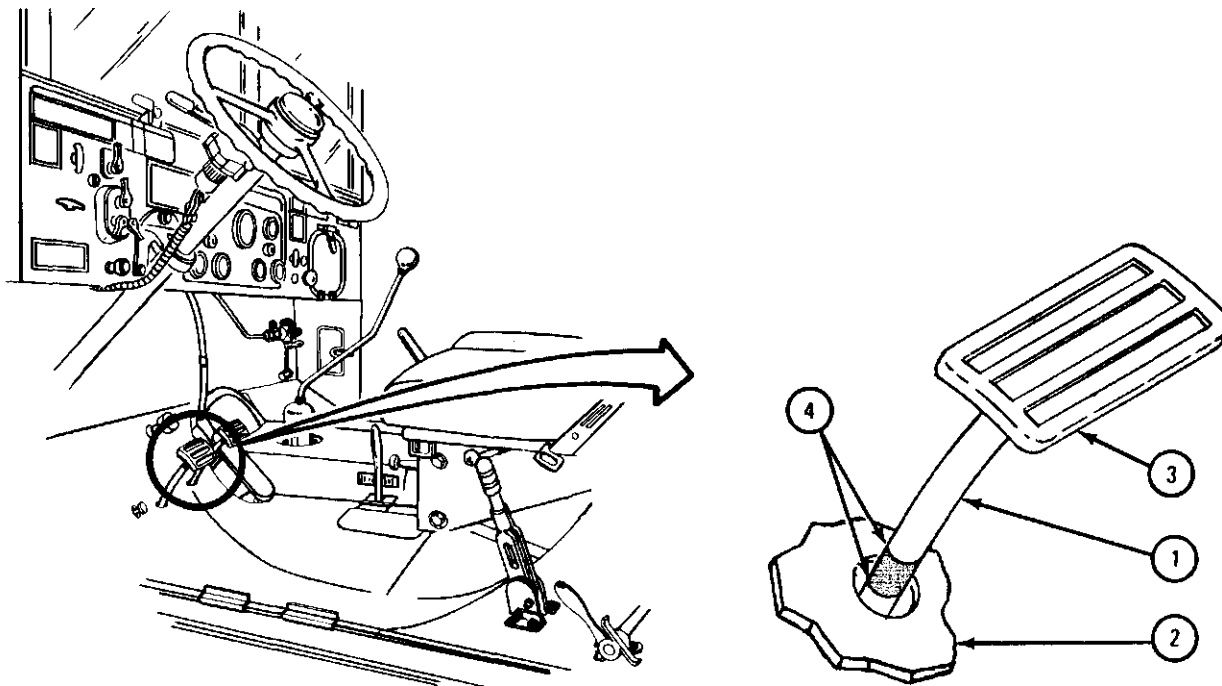

TA 047265

e. Adjustment.

FRAME 1

NOTE

Refer to para 3-3d of clutch control and linkages replacement procedure to check free pedal travel.

1. Using 3/4-inch wrenches, hold clevis (1) and loosen nut (2) .
2. Pull pin (3) to one side of clevis (1). Pull clevis away from throwout shaft lever (4).
3. If free pedal travel is less than 1 1/2 inches, shorten length of rod (5) by screwing clevis (1) into rod.
4. If free pedal travel is more than 2 inches, make length of rod (5) longer by unscrewing clevis (1).
5. After setting length of rod (5) , join clevis (1) to throwout shaft lever (4) . Using prybar, pry pin (3) (from transmission side) through clevis until pin is seated.
6. Recheck free pedal travel.
7. If free pedal travel is 1 1/2 to 2 inches, using 3/4-inch wrench, tighten nut (2) against clevis (1) .

END OF TASK

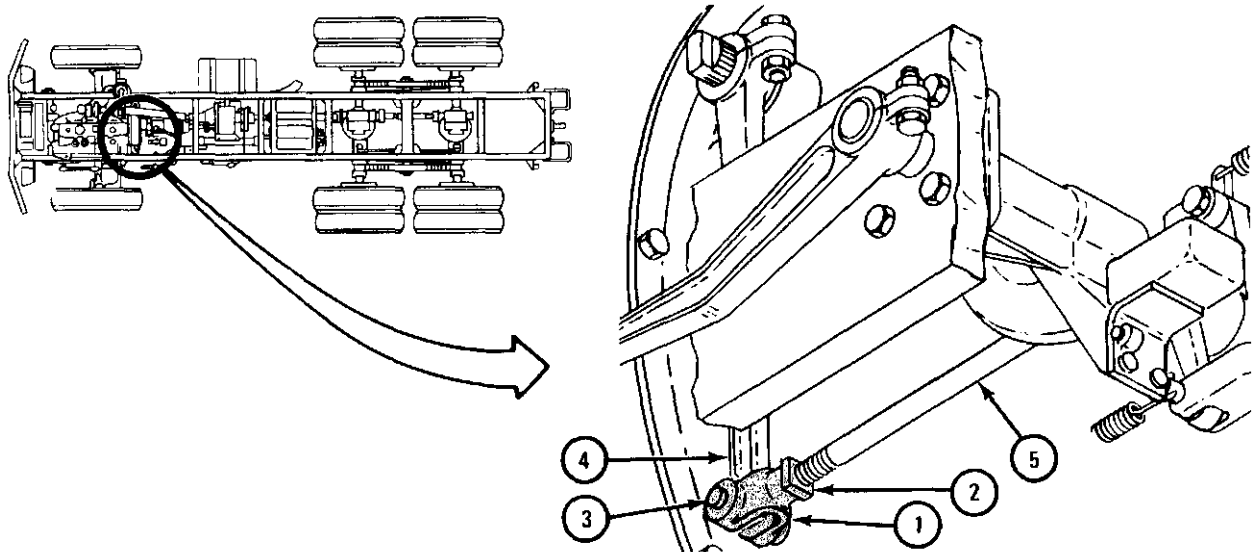

TA 047266

CHAPTER 4

FUEL SYSTEM GROUP MAINTENANCE

Section I. SCOPE

4-1. EQUIPMENT ITEMS COVERED . This chapter gives equipment maintenance procedures for the air cleaner, fuel tanks and fuel lines, fuel filter, engine starting aids, and accelerator, throttle and engine stop controls for which there are authorized corrective maintenance tasks at the organizational maintenance level.

4-2. EQUIPMENT ITEMS NOT COVERED . All equipment items for which corrective maintenance is authorized at the organizational maintenance level are covered in this chapter.

Section II. AIR CLEANER

4-3. INTAKE AIR CLEANER REMOVAL, REPAIR, AND REPLACEMENT .

TOOLS : 9/16-inch open end wrench (2)
7/16-inch wrench (2)
Flat-tip screwdriver

SUPPLIES : None

PERSONNEL : Two

EQUIPMENT CONDITION : Truck parked, engine off, handbrake set.

Preliminary Procedure. Remove air cleaner filter element. Refer to
TM 9-2320-209-10.

b. Removal.

FRAME 1

1. Using 9/16-inch wrenches, unscrew coupling nut (1) from connector and filter (2). Pull tube assembly (3) away from connector and filter.
2. Using 7/16-inch wrench, unscrew and take connector filter (2) out of air cleaner head (4).
3. Using flat-tip screwdriver, loosen clamp screw (5) and take tube assembly (6) off air cleaner head (4).

GO TO FRAME 2

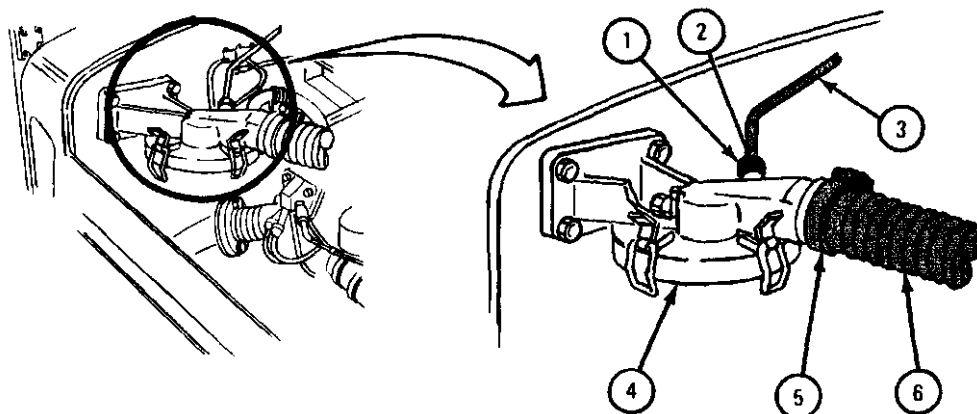

TA 047138

FRAME 2

- Soldier A 1. Reaching up behind instrument panel (1) and using 9/16-inch wrench, hold air cleaner mounting nut (2) .
- Soldier B 2. While holding air cleaner head (3) using 9/16-inch wrench, take out four air cleaner mounting bolts (4) with lockwashers (5) .
3. Lift out air cleaner head (3) .
- Soldier A 4. Take off air cleaner mounting nut (2).
- END OF TASK

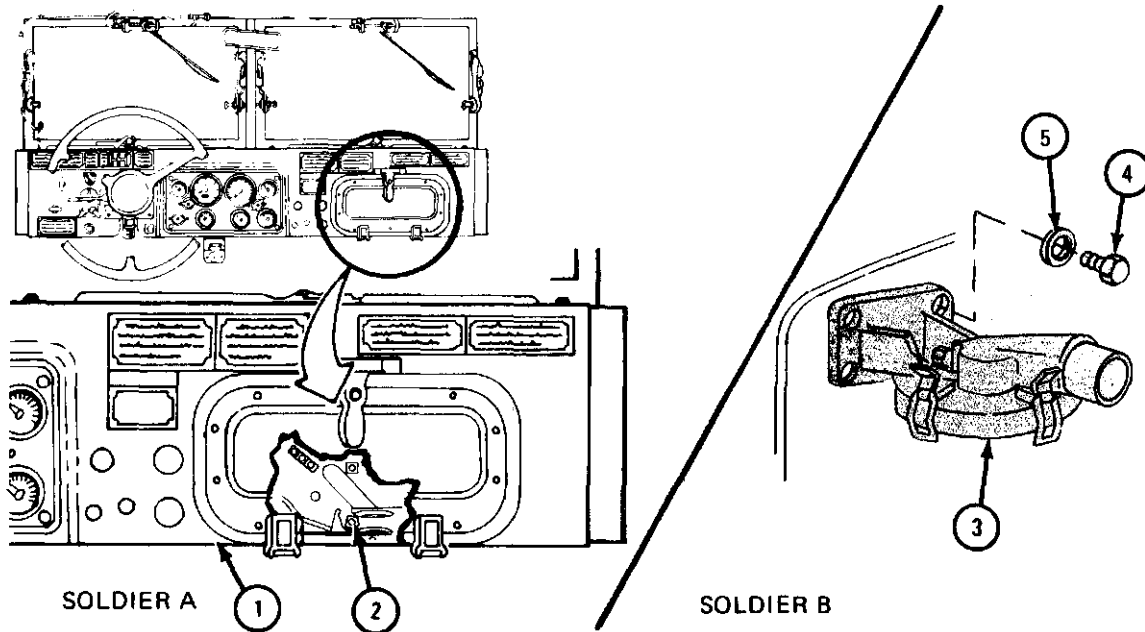

TA 047140

- c. Repair. Repair air cleaner by replacing damaged or unserviceable parts.
- d. Replacement.

FRAME 1

1. Place air cleaner head (1) against firewall (2) as shown and align four mounting holes.
2. Put four bolts (3) with four lockwashers (4) through air cleaner head (1) and firewall (2) .

GO TO FRAME 2

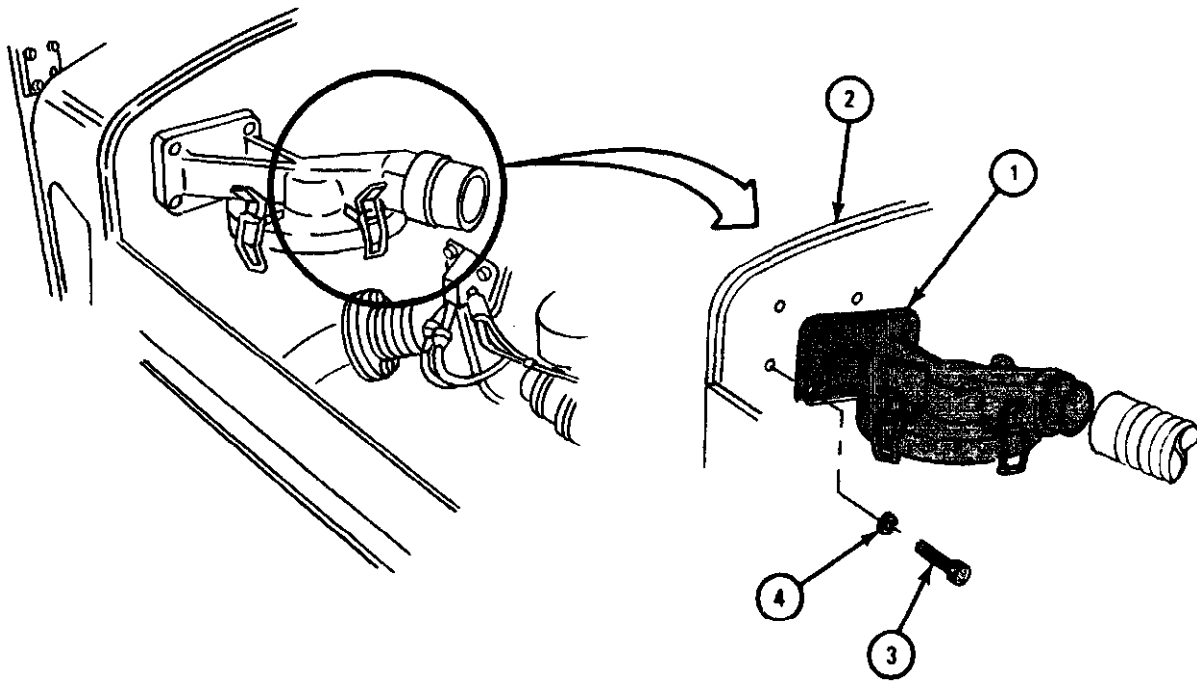

TA 047141

FRAME 2

- Soldier A 1. Reaching up behind instrument panel (1) and using 9/16-inch wrench, hold air cleaner mounting nut (2) in place on bracket (3) . Tell soldier B when ready.
- Soldier B 2. Using 9/16-inch wrench, screw in and tighten four air cleaner mounting bolts (4) .
3. Put tube assembly (5) on air cleaner head (6). Using flat-tip screwdriver, tighten clamp screw (7) .
4. Using 7/16-inch wrench, screw in and tighten connector and filter (8) into hole in air cleaner head (6).
5. Using 9/16-inch wrench, screw in and tighten coupling nut (7) into connector and filter assembly (8) .

NOTE

Follow-on Maintenance Action Required:

1. Replace air filter element. Refer to TM 9-2320-209-10.
2. Close hood and left side panel. Refer to TM 9-2320-209-10.

END OF TASK

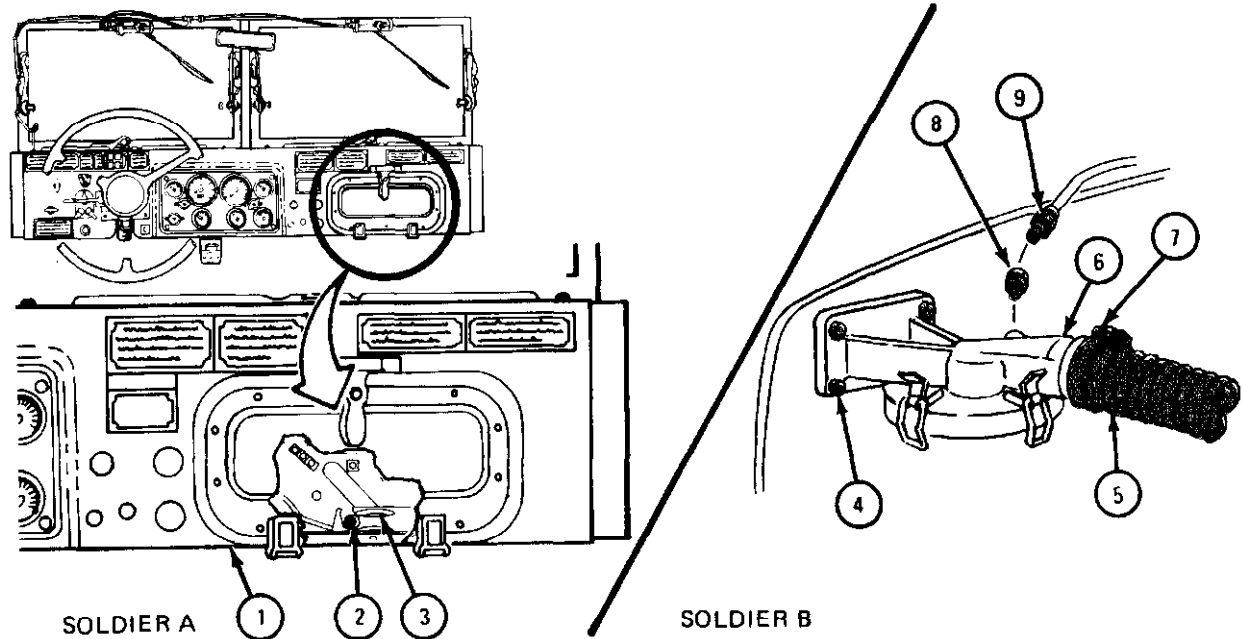

TA 047142

4-4. AIR CLEANER INDICATOR REMOVAL AND REPLACEMENT.

TOOLS : 7/16-inch open end wrench
9/16-inch wrench (2)

SUPPLIES : None

PERSONNEL: One

EQUIPMENT CONDITION: Truck parked, engine off, handbrake set.

Removal.

FRAME 1

1. Working from behind instrument panel and using 7/16-inch wrench, hold connector fitting (1). Using 9/16-inch wrench, unscrew fitting (2) and take off tube assembly (3). Unscrew and take off connector fitting.
2. Using 7/16-inch wrenches, unscrew and take off two capscrews (4), washers (5), and nuts (6) and take off air cleaner indicator (7).

END OF TASK

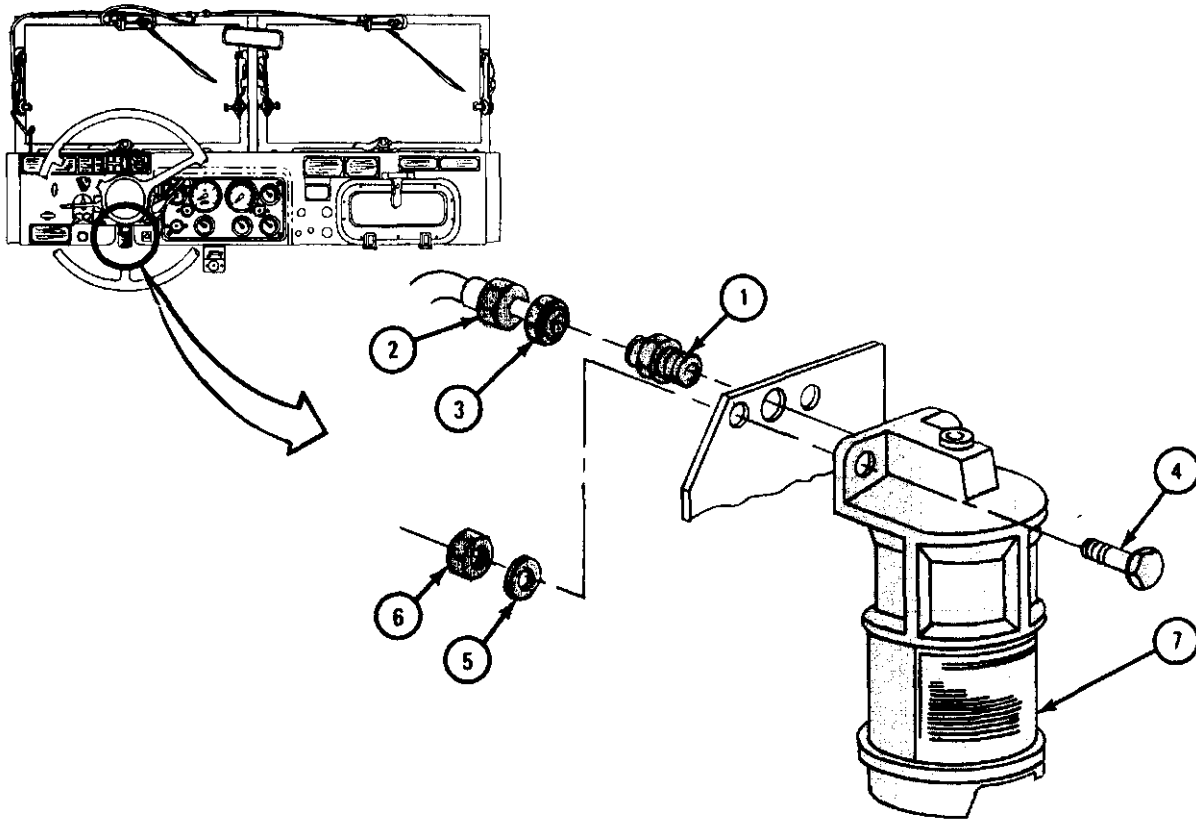

TA 080844

b. Replacement.**FRAME 2**

1. Aline screw holes in air cleaner indicator (1) with screw holes in bracket (2) and put in two cap screws (3) .
2. Using 7/16-inch wrenches, hold two capscrews (3) and screw on and tighten two washers (4) and nuts (5) .
3. Working from behind instrument panel and using 7/16-inch wrench, screw in connector fitting (6) . Hold connector fitting and using 9/16-inch wrench, screw in and tighten fitting (7) .

END OF TASK

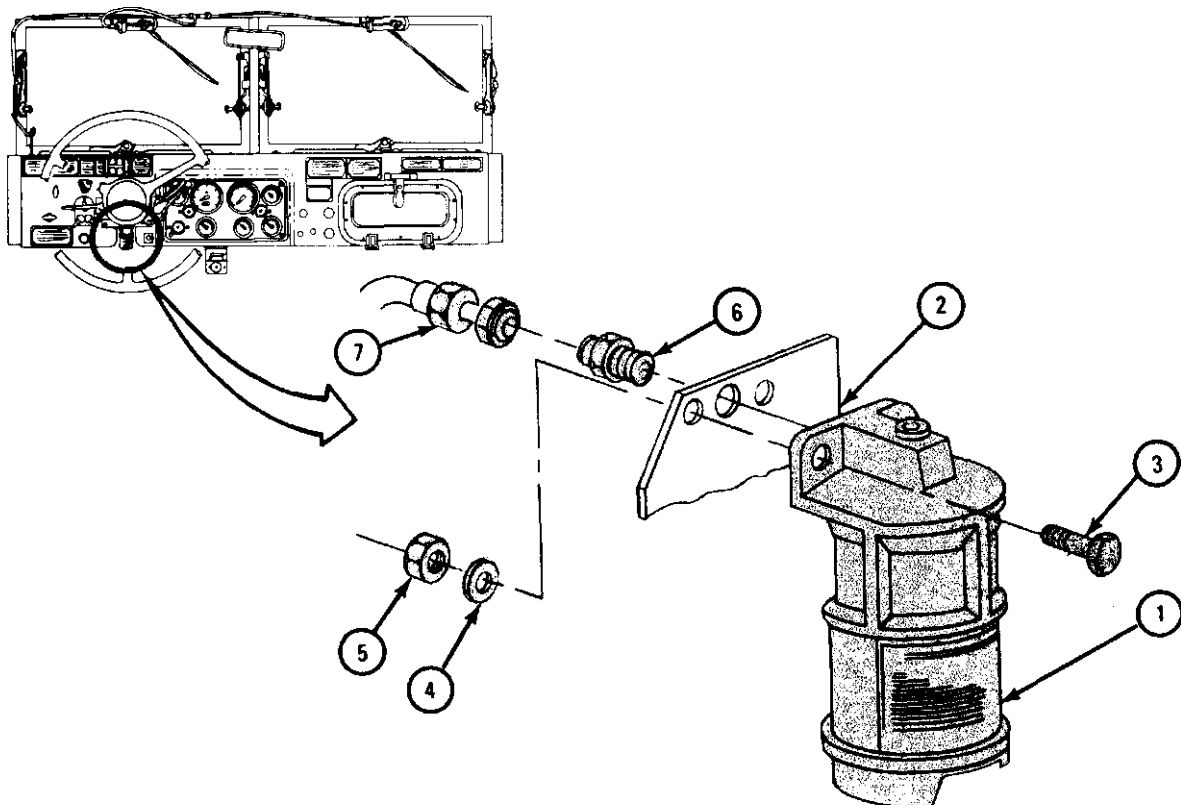

TA 080845

Section III. FUEL TANKS AND FUEL LINES

4-5. FUEL LINES AND FITTINGS REMOVAL AND REPLACEMENT.

NOTE

Procedures given are typical and cover all the different types of installations that you will find on the trucks. Procedures do not show any one truck system. Refer to system schematic illustrations used as support diagrams for troubleshooting each system given in vol. 3, chapter 10.

TOOLS : 3/4-inch combination box and open end box wrench
7/16-inch combination box and open end box wrench (2)
11/16-inch combination box and open end box wrench
5/8-inch combination box and open end box wrench
10-inch pipe wrench
3/16-inch sockethead screw key (Allen wrench or equivalent)

SUPPLIES : Sealer compound, type II, MIL-S-45180

PERSONNEL : One

EQUIPMENT CONDITION : Truck parked, engine off, handbrake set.

WARNING

Smoking, flames, sparks and glowing or hot objects are not allowed within 50 feet of work area during maintenance of fuel system components. Fuel can explode, causing injury to personnel and damage to equipment.

a. Removal,

- (1) Fuel tubes and clamps (low pressure).

NOTE

Fuel supply line from fuel filter to tube coupling on trucks with LD-465 engine is used for this typical procedure.

FRAME 1

1. Working under right side of truck and using 5/8-inch open end wrench, hold adapter fitting (1). Using 3/4-inch combination box and open end box wrench, unscrew and take off tube nut (2).

GO TO FRAME 2

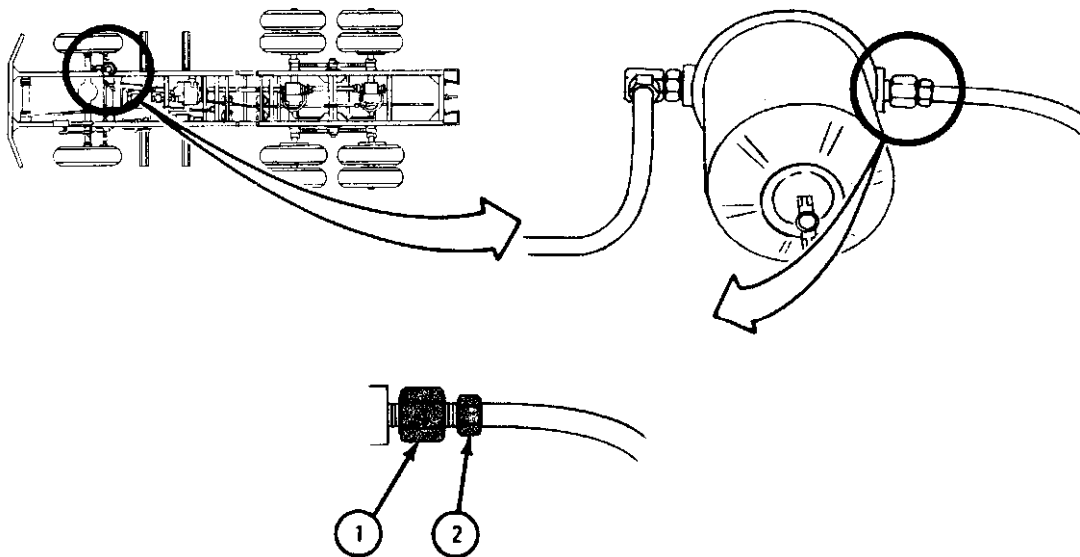

TA 087070

FRAME 2

1. Using 7/8-inch open end wrench, hold tube coupling (1). Using 3/4-inch combination box and open end wrench, unscrew and take off tube nut (2) .

NOTE

The number of clamps may be different on any tube.
 Make sure that all capscrews and nuts are taken off
 before taking off tube.

2. Using 7/16-inch wrenches, hold cap screw (3) and unscrew and take off nut (4). Take out cap screw (3) and tube (5).
3. Spread open and take off clamp (6) .

END OF TASK

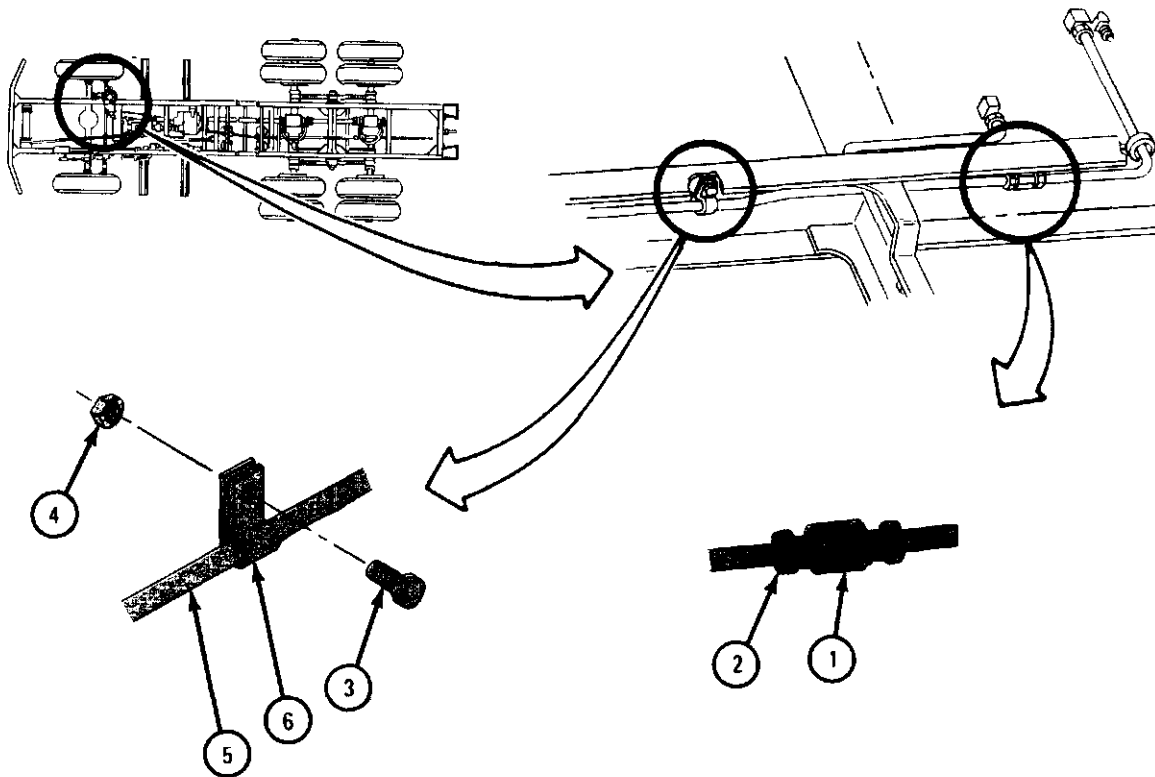

TA 087071

(2) Fuel hoses.

NOTE

Fuel return hose from secondary and final filter assemblies to return tube on trucks with LD- 465 engine is used for this typical procedure.

FRAME 1

1. Open hood and left side panel. Refer to TM 9-2320-209-10.
 2. Using 9/16-inch open end wrench, hold elbow (1) . Using 11/16-inch combination box and open end box wrench, unscrew and take off hose nut (2).
- GO TO FRAME 2

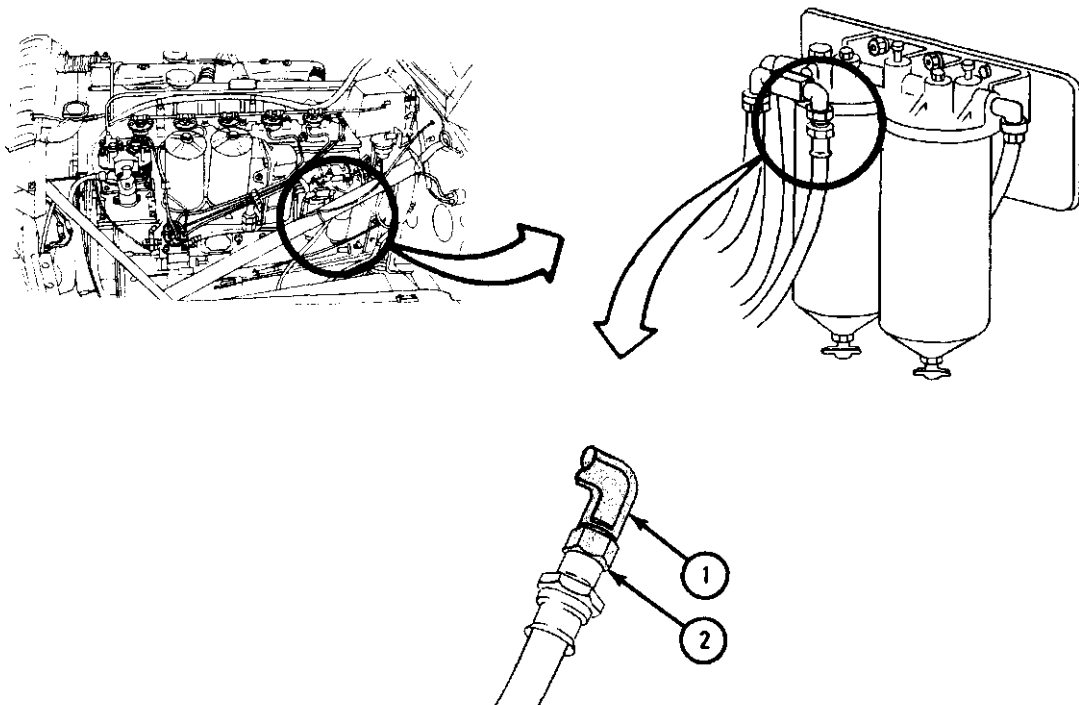

TA 087072

FRAME 2

1. Using 11/16-inch open end wrench, hold hose nut (1). Using 3/4-inch combination box and open end box wrench, unscrew tube nut (2) and take off fuel hose (3).

END OF TASK

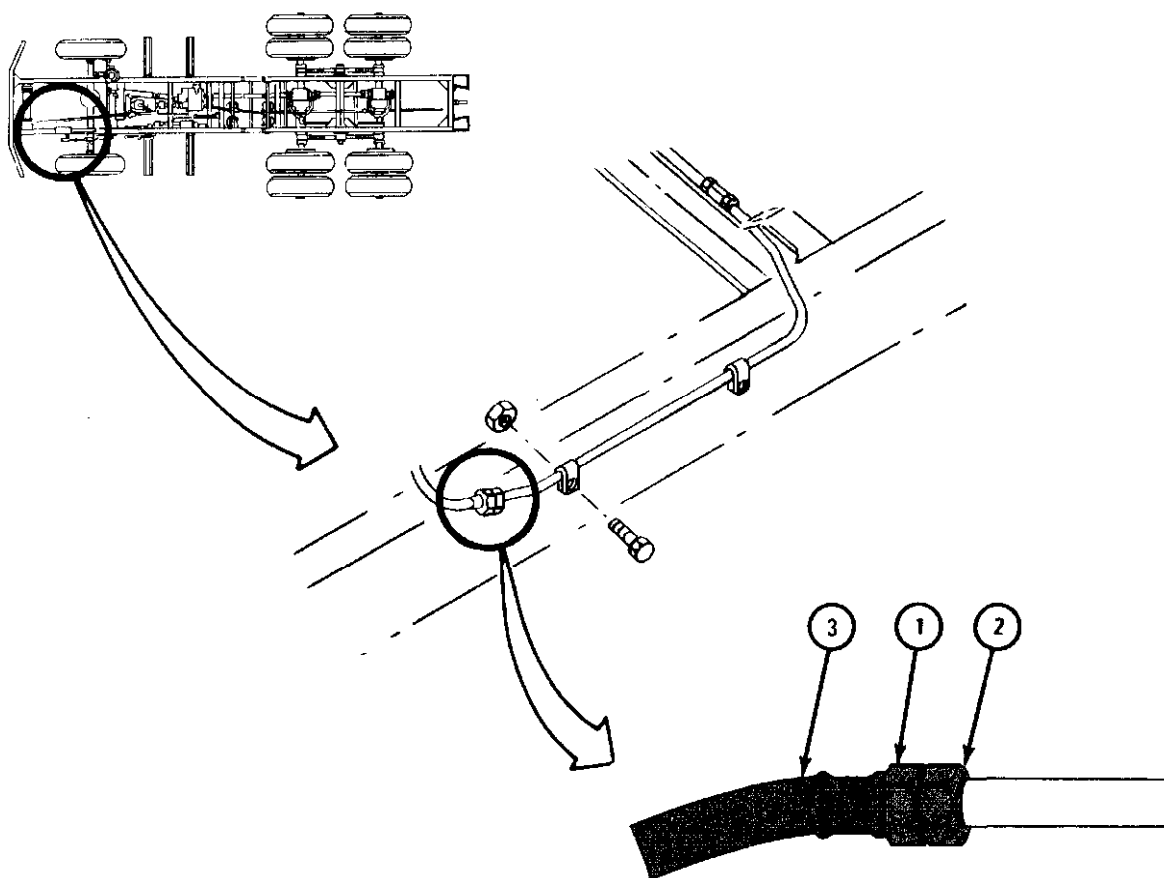

TA 087073

- (3) Fuel line fittings.
(a) Tube coupling

NOTE

Tube coupling joining fuel supply tube from fuel tank and fuel supply tube to filter on trucks with LD-465 engine is used for this typical procedure.

FRAME 1

1. Using 7/8-inch open end wrench, hold tube coupling (1). Using 3/4 inch combination box and open end box wrench, unscrew tube nuts (2 and 3) and take off tube coupling (1) .

END OF TASK

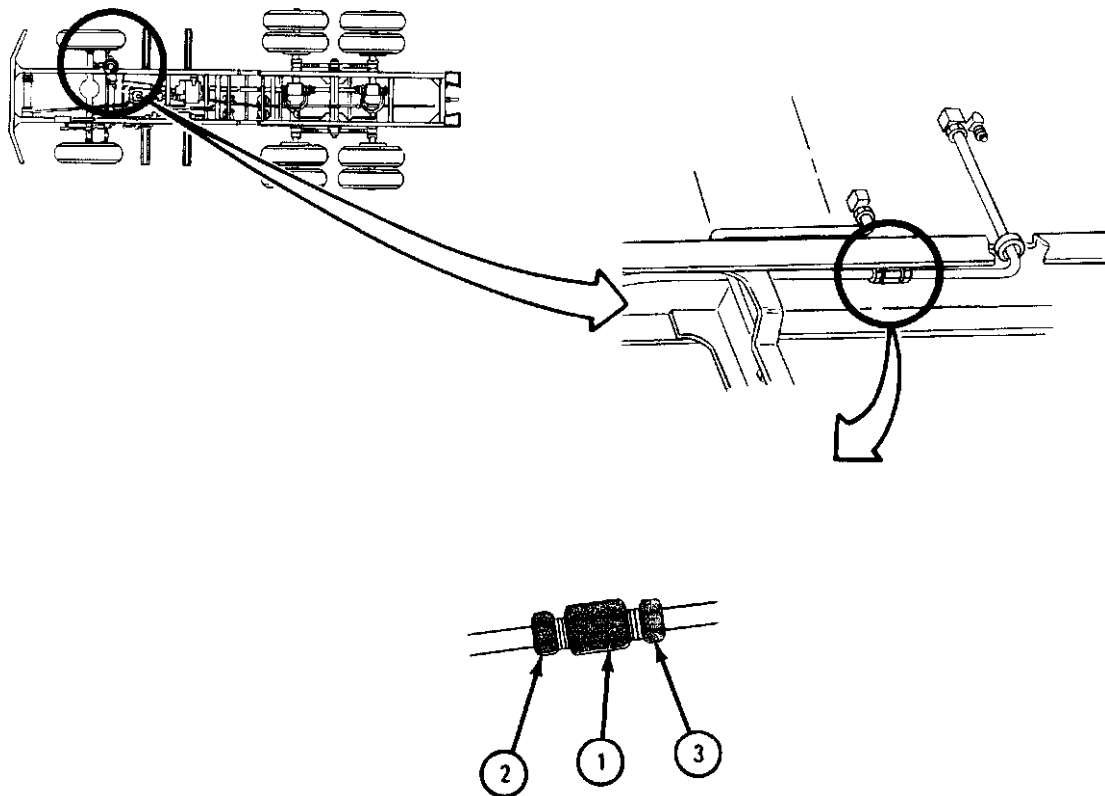

TA 087074

(b) Pipe plug

NOTE

Pipe plug in fuel return elbow at fuel tank on trucks with LD-465 engine is used for this typical procedure.

FRAME 1

1. Using 3/16-inch allen wrench, unscrew and take off pipe plug (1) .
END OF TASK

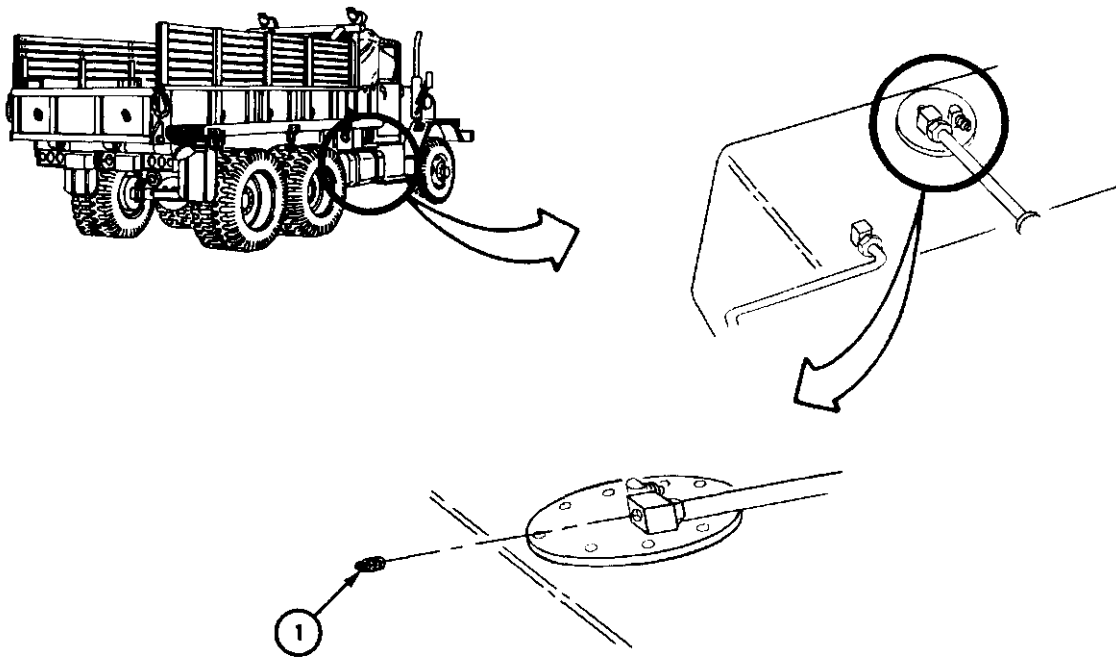

TA 087075

(c) Adapter fitting

NOTE

Adapter fitting at primary fuel filter on trucks with LD- 465 engine is used for this typical procedure.

FRAME 1

1. Using 7/8-inch open end wrench, hold adapter fitting (1). Using 3/4-inch combination box and open end box wrench, unscrew and take off tube nut (2) with tube (3).
2. Using 7/8-inch open end wrench, unscrew and take off adapter fitting (1).

END OF TASK

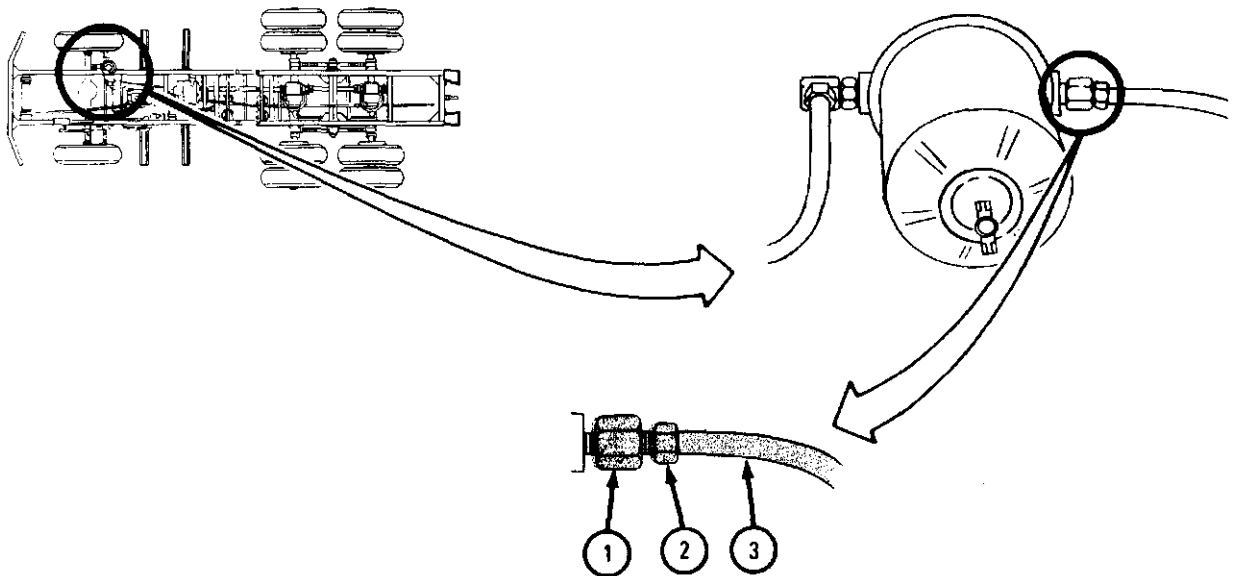

TA 087076

(d) Bushing

NOTE

Bushing at primary fuel filter on trucks with LD - 465 engine is used for this typical procedure.

FRAME 1

1. Using 3/4-inch combination box and open end box wrench, unscrew and take off tube nut (1).
2. Using 7/8-inch open end wrench, hold bushing (2) . Using 10-inch pipe wrench, unscrew and take off elbow (3).
3. Using 7/8-inch open end wrench, unscrew and take off bushing (2) .

END OF TASK

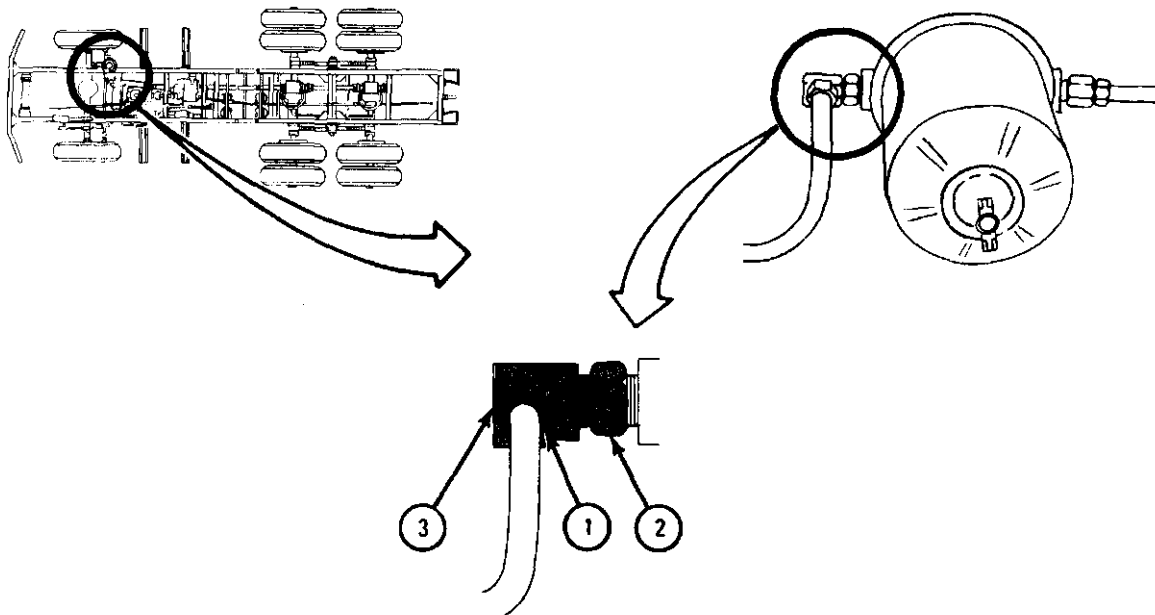

TA 087077

(e) Tee fitting

NOTE

Tee fitting at secondary and final filter assemblies on truck with LD-465 engine is used for this typical procedure.

FRAME 1

1. Open hood and left side panel. Refer to TM 9-2320-209-10.
2. Using 5/8-inch combination box and open end wrench, unscrew and take off tube nut (1). Using 9/16-inch wrench, unscrew and take off elbow (2) .
3. Using 9/16-inch open end wrench, hold elbow (3). Using 11/16-inch combination box and open end box wrench, unscrew and take off hose nut (4) . Using 9/16-inch wrench, unscrew and take off elbow (3) .
4. Using 10-inch pipe wrench, unscrew and take off tee fitting (5) .

END OF TASK

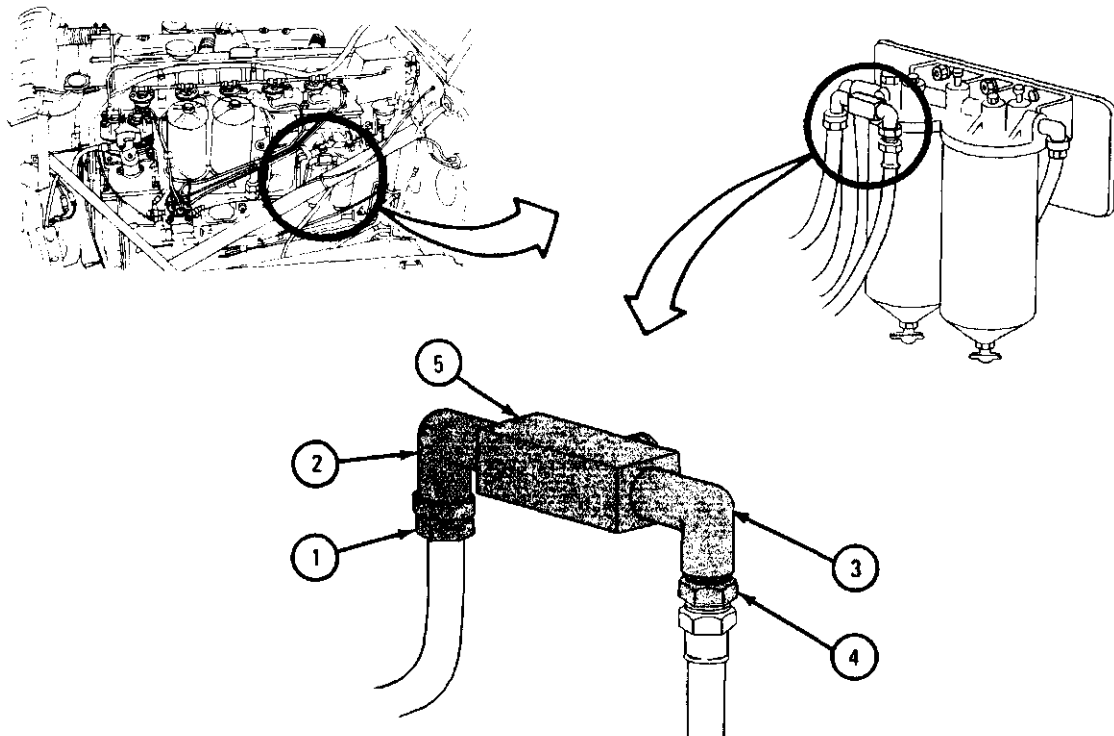

TA 087078

(f) Elbow

NOTE

Elbow at primary fuel filter on trucks with LD-465 engine is used for this typical procedure.

FRAME 1

1. Using 3/4-inch combination box and open end box wrench, unscrew and take off tube nut (1) .
2. Using 7/8-inch open end wrench, hold bushing (2). Using 10-inch pipe wrench, unscrew and take off elbow (3) .

END OF TASK

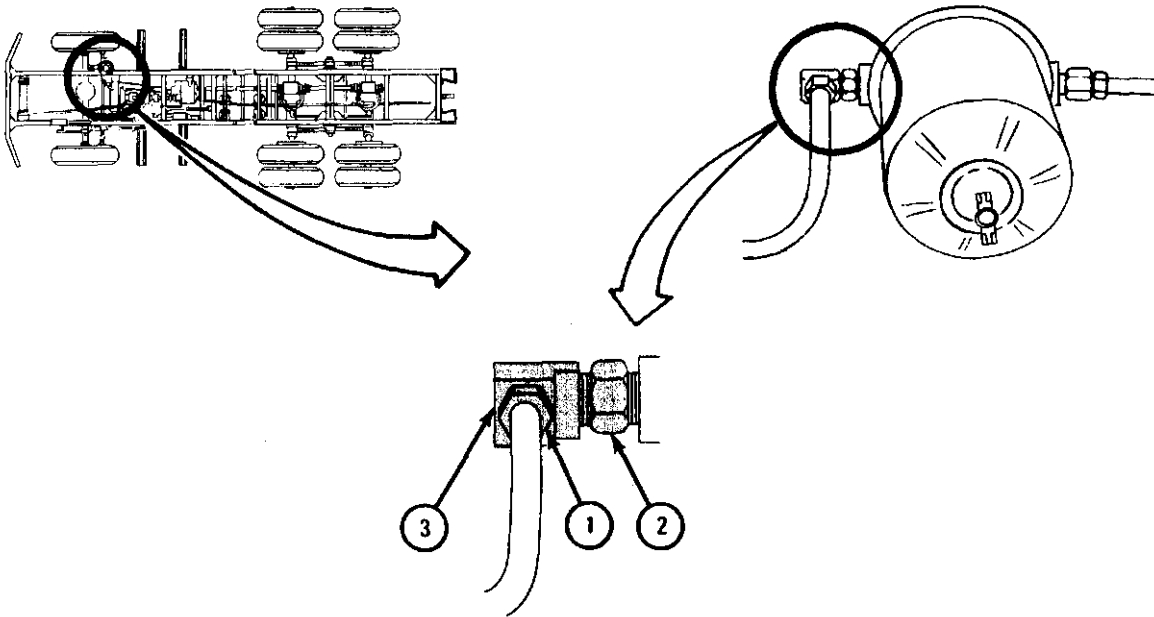

TA 087077

b. Replacement.

NOTE

Put a thin coat of sealer compound on all threaded fittings before putting them back.

- (1) Fuel tubes and clamps.

CAUTION

Fittings are made of soft brass. They can be stripped very easily if overtightened. Tighten fittings only enough to stop fuel leaking.

NOTE

Fuel supply line from fuel filter to tube coupling on trucks with LD-465 engine is used for this typical procedure.

FRAME 1

1. Using 7/8-inch open end wrench, hold adapter (1). Using 3/4-inch combination box and open end box wrench, screw on and tighten tube nut (2).

GO TO FRAME 2

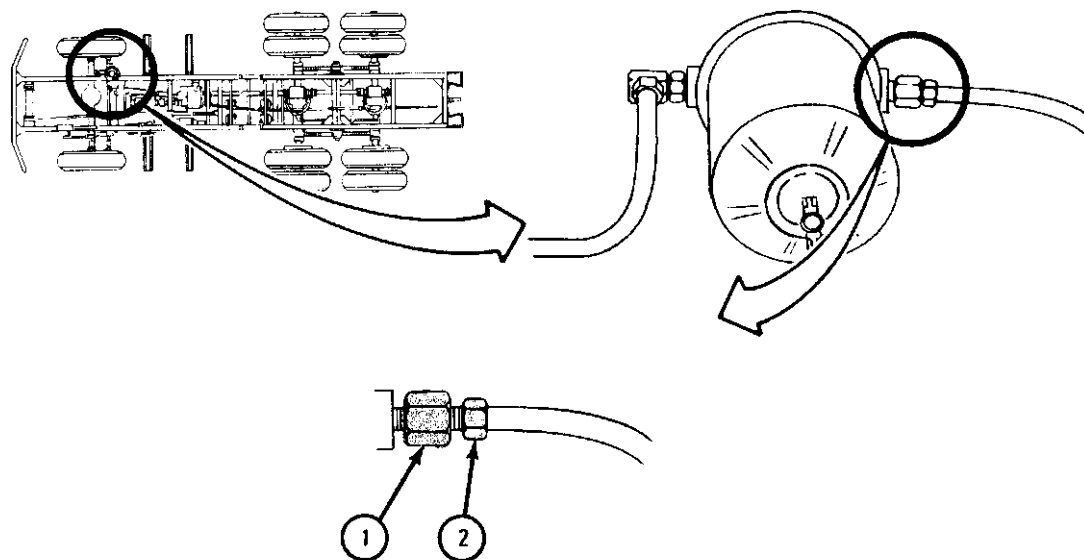

TA 087070

FRAME 2

1. Using 7/8-inch open end wrench, hold coupling (1). Using 3/4-inch combination box and open end box wrench, screw on and tighten tube nut (2).

NOTE

The number of clamps (3) may be different on any tube. Make sure that all clamps are put back.

2. Put clamp (3) on tube (4). Using 7/16-inch open end wrenches, put in and hold capscrew (5) and screw on and tighten nut (6).

NOTE

Follow-on Maintenance Action Required:

1. Start engine. Refer to TM 9-2320-209-10.
2. Check that fuel lines and fittings have no leaks.
3. Stop engine. Refer to TM 9-2320-209-10.

END OF TASK

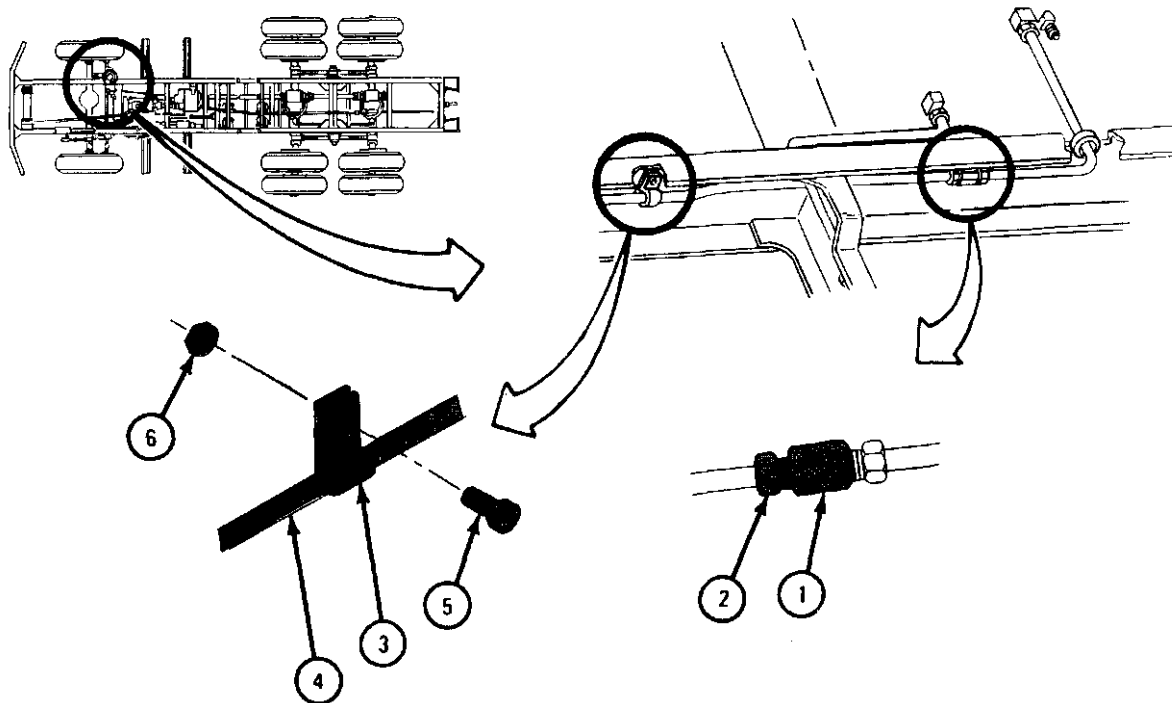

TA 087080

(2) Fuel hoses.

CAUTION

Fittings are made of soft brass. They can be stripped very easily if overtightened. Tighten fittings only enough to stop fuel leaking.

NOTE

Fuel return hose from secondary and final filter assemblies to return tube on trucks with LD-465 engine is used for this typical procedure.

FRAME 1

1. Using 9/16-inch open end wrench, hold elbow (1) . Using 11/16-inch combination box and open end box wrench, screw on and tighten hose nut (2) .

GO TO FRAME 2

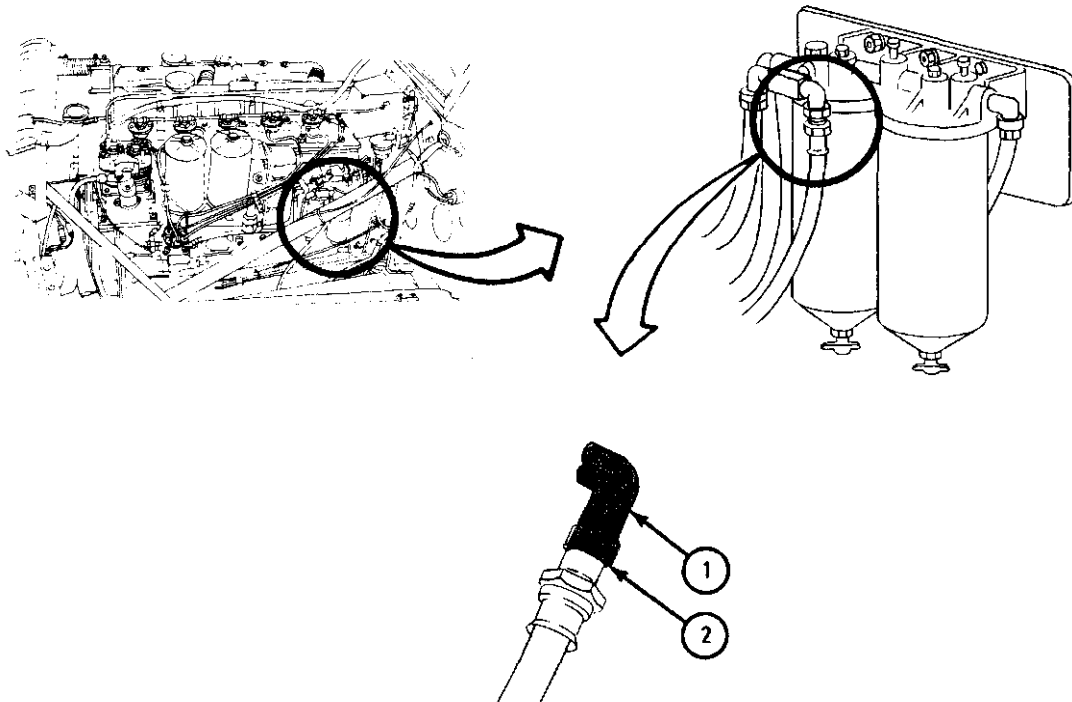

TA 087072

FRAME 2

1. Using 3/4-inch open end wrench, hold hose nut (1). using 5/8 inch combination box and open end box wrench, screw on and tighten tube nut (2).

NOTE

Follow-on Maintenance Action Required:

1. Start engine. Refer to TM 9-2320-209-10.
2. Check that fuel lines and fittings have no leaks.
3. Close hood and left side panel. Refer to TM 9-2320-209-10.
4. Stop engine. Refer to TM 9-2320-209-10.

END OF TASK

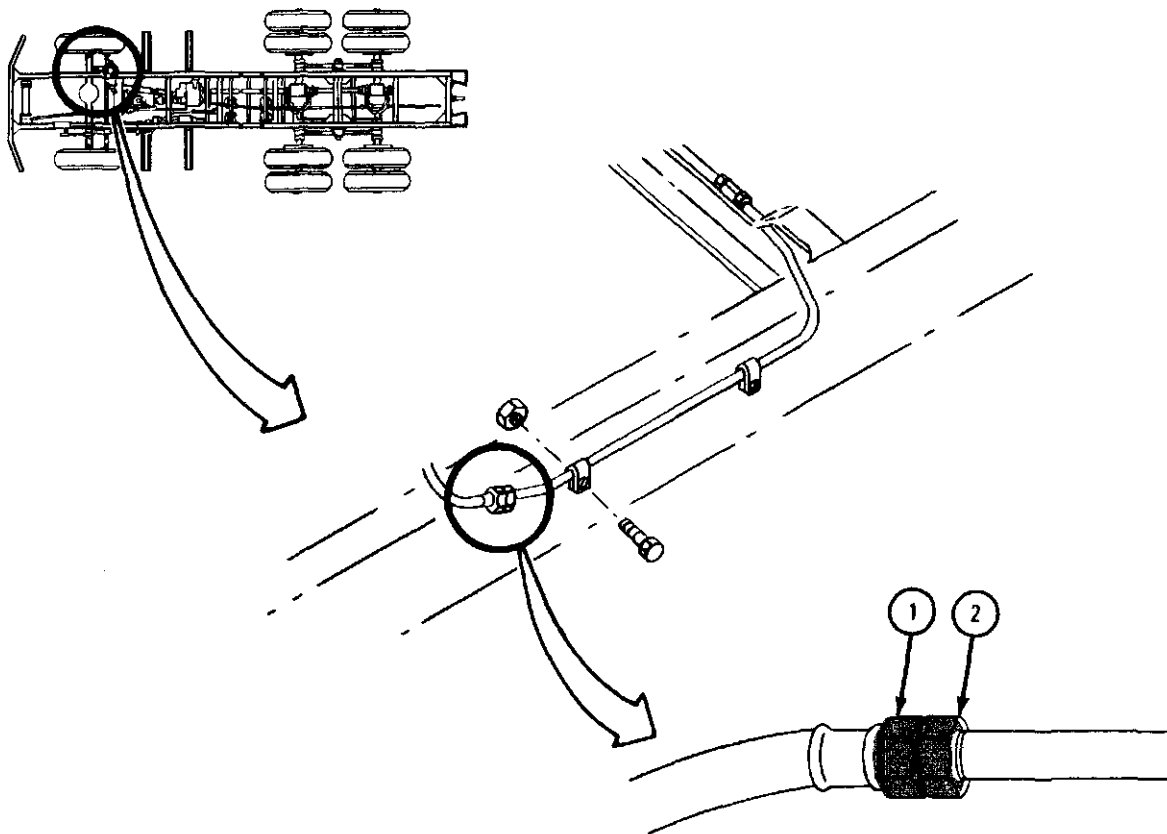

TA 087081

(3) Fuel line fittings.

(a) Tube coupling

CAUTION

Fittings are made of soft brass. They can be stripped very easily if overtightened. Tighten fittings only enough to stop fuel leaking.

NOTE

Tube coupling joining fuel supply tube from fuel tank and fuel supply tube to filter on trucks with LD-465 engine is used for this typical procedure.

FRAME 1

1. Screw tube nuts (1 and 2) into coupling (3).
2. Using 7/8-inch open end wrench, hold coupling (3). Using 3/4-inch combination box and open end box wrench, tighten two tube nuts (1 and 2).

NOTE

Follow-on Maintenance Action Required:

1. Start engine. Refer to TM 9-2320-209-10.
2. Check that fuel lines and fittings have no leaks.
3. Stop engine. Refer to TM 9-2320-209-10.

END OF TASK

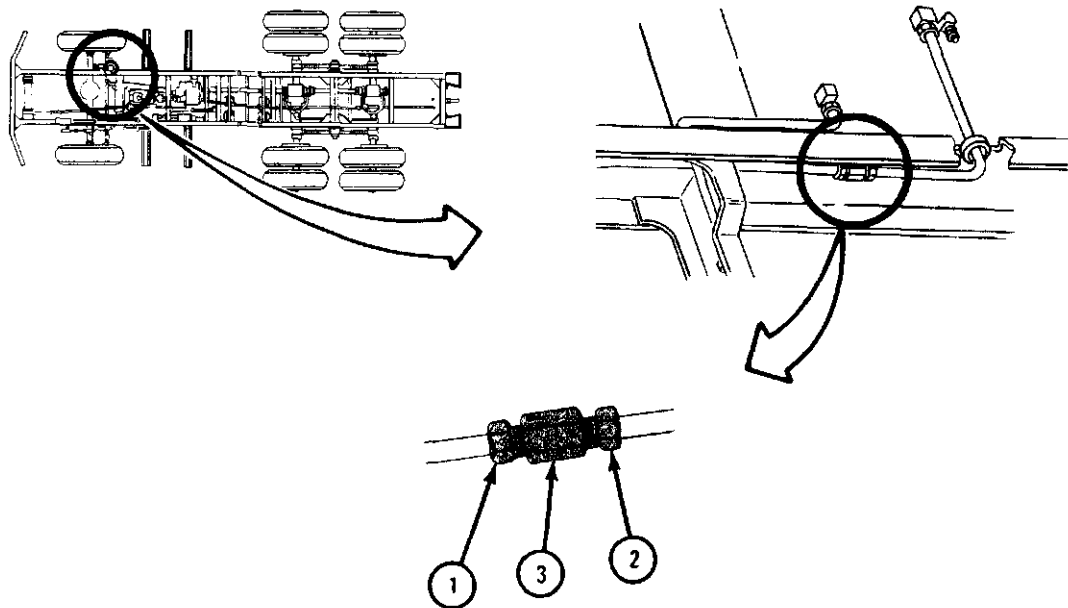

TA 087082

(b) Pipe plug

CAUTION

Fittings are made of soft brass. They can be stripped very easily if overtightened. Tighten fittings only enough to stop fuel leaking.

NOTE

Pipe plug in fuel return elbow of fuel tank on trucks with LD-465 engine is used for this typical procedure,

FRAME 1

1. Using 3/16-inch allen wrench, screw in and tighten plug (I).

NOTE

Follow -on Maintenance Action Required:

1. Start engine. Refer to TM 9-2320-209-10.
2. Check that fuel lines and fittings have no leaks.
3. Stop engine. Refer to TM 9-2320-209-10.

END OF TASK

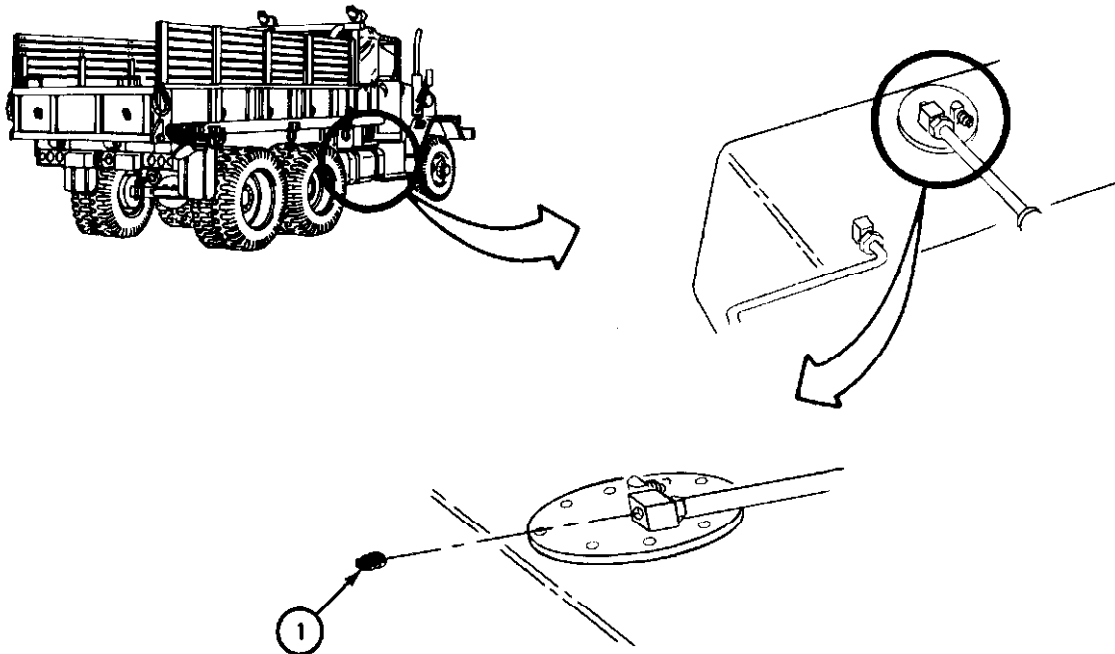

TA 087075

(c) Adapter fitting

CAUTION

Fittings are made of soft brass. They can be stripped very easily if overtightened. Tighten fittings only enough to stop fuel leaking.

NOTE

Adapter fitting at primary fuel filter on trucks with LD-465 engine is used for this typical procedure.

FRAME 1

1. Using 7/8-inch open end wrench, screw on and tighten adapter fitting (1).
2. Using 7/8-inch open end wrench, hold adapter (1). Using 3/4-inch combination box and open end wrench, screw on and tighten tube nut (2).

NOTE**Follow-on Maintenance Action Required:**

1. Start engine. Refer to TM 9-2320-209-10.
2. Check that fuel lines and fittings have no leaks.
3. Stop engine. Refer to TM 9-2320-209-10.

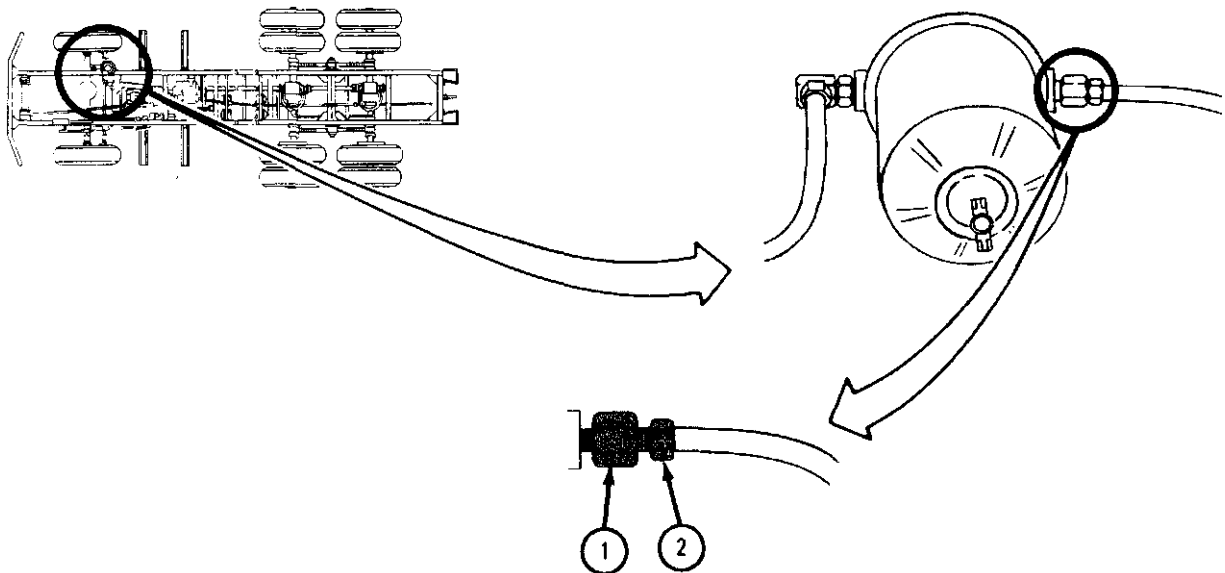
END OF TASK

TA 087076

(d) Bushing

CAUTION

Fittings are made of soft brass. They can be stripped very easily if overtightened. Tighten fittings only enough to stop fuel leaking.

NOTE

Bushing at primary filter on trucks with LD-465 engine is used for this typical procedure.

FRAME 1

1. Using 7/8-inch open end wrench, screw in and tighten bushing (1).
2. Using 7/8-inch open end wrench, hold bushing (1). Using 10-inch pipe wrench, screw in and tighten elbow (2).
3. Using 3/4-inch combination box and open end box wrench, screw on and tighten tube nut (3).

NOTE

Follow -on Maintenance Action Required:

1. Start engine. Refer to TM 9-2320-209-10.
2. Check that fuel lines and fittings have no leaks.
3. Stop engine. Refer to TM 9-2320-209-10

END OF TASK

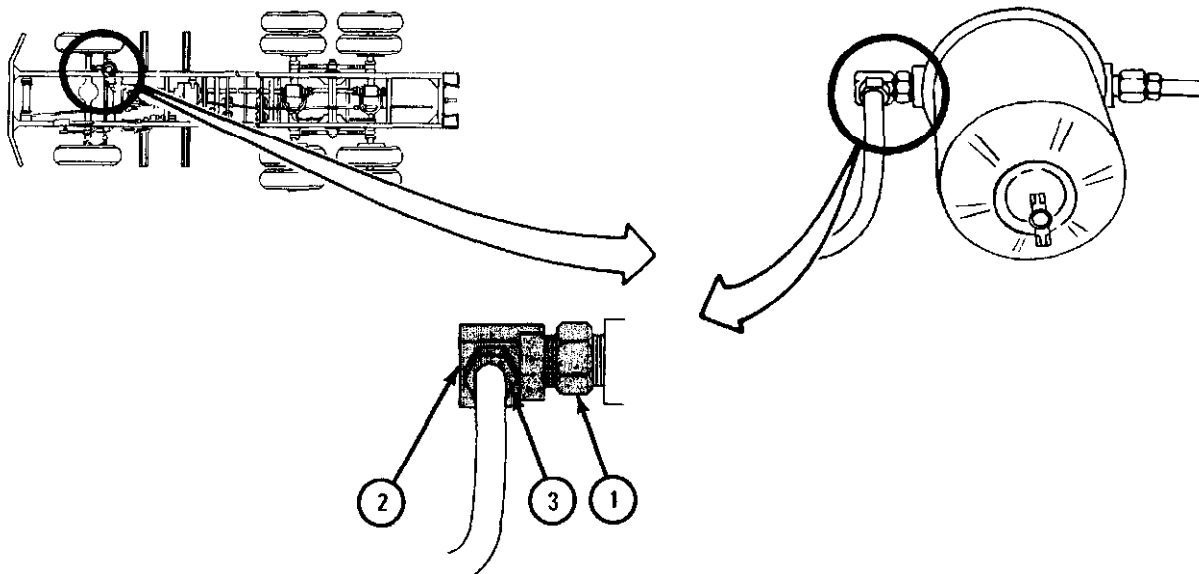

TA 087083

(e) Tee fitting

CAUTION

Fittings are made of soft brass. They can be stripped very easily if overtightened. Tighten fittings only enough to stop fuel 1 caking.

NOTE

Tee fitting at the secondary and final filter assemblies on trucks with LD-465 engine is used for this typical procedure.

FRAME 1

1. Using 10-inch pipe wrench, screw in and tighten tee fitting (1).
2. Using 9/16-inch wrench, screw in and tighten elbow (2).
3. Using 11/ 16-inch combination box and open end box wrench, screw on and tighten hose nut (3).
4. Using 9/16-inch wrench, screw in and tighten elbow (4). Using 5/8-inch combination box and open end box wrench, screw on and tighten tube nut (5).

NOTE

Follow-on Maintenance Action Required:

1. Start engine. Refer to TM 9-2320-209-10.
2. Check that fuel lines and fittings have no leaks.
3. Close hood and left side panel. Refer to TM 9-2320-209-10.
4. Stop engine. Refer to TM 9-2320-209-10.

END OF TASK

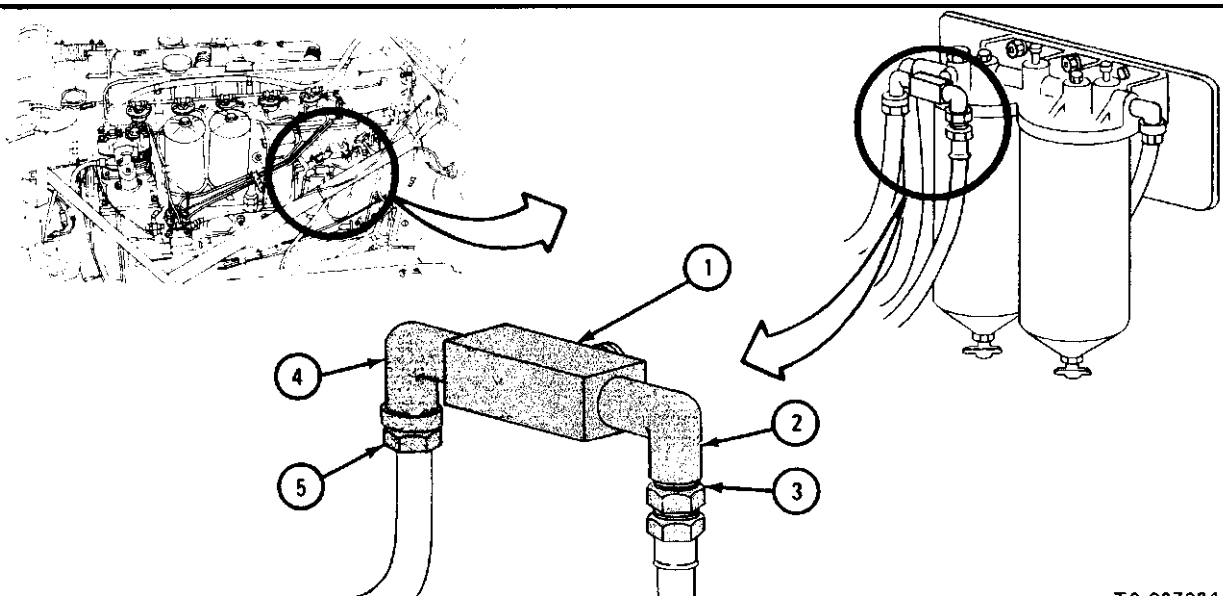

TA 087084

(f) Elbow

CAUTION

Fittings are made of soft brass. They can be stripped very easily if overtightened. Tighten fittings only enough to stop fuel leaking.

NOTE

Elbow at primary fuel filter on trucks with LD-465 engine is used for this typical procedure.

FRAME 1

1. Using 7/8-inch open end wrench, hold bushing (1). Using 10-inch pipe wrench, screw in and tighten elbow (2).
2. Using 3/4-inch combination box and open end box wrench, screw on and tighten tube nut (3).

NOTE

Follow -on Maintenance Action Required:

1. Start engine. Refer to TM 9-2320-209-10.
2. Check that fuel lines and fittings have no leaks.
3. Stop engine. Refer to TM 9-2320-209-10.

END OF TASK

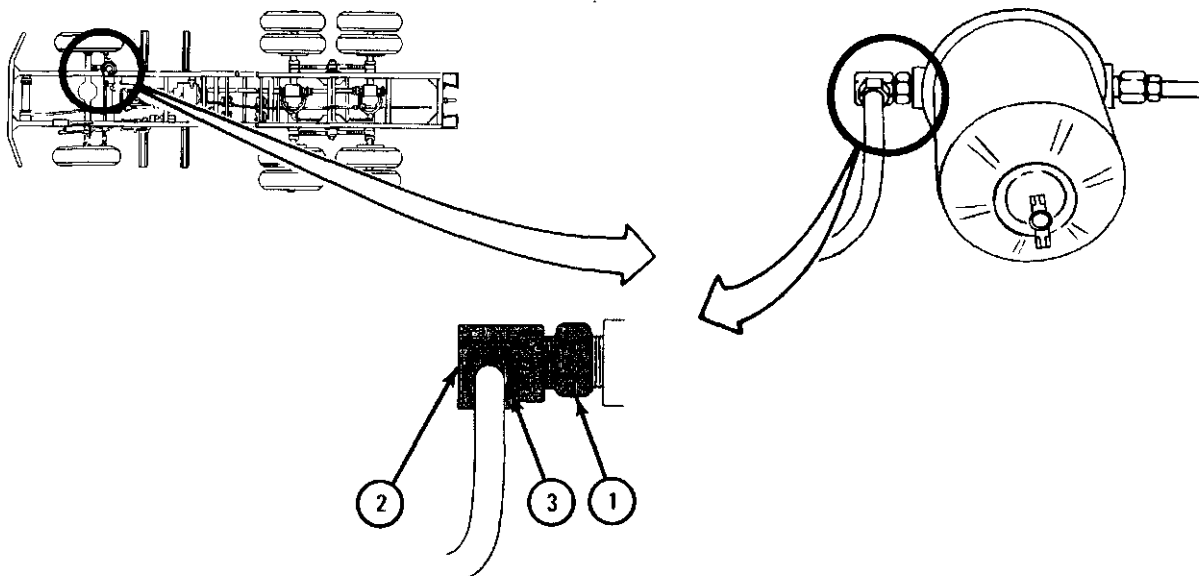

TA 087083

4-6. FUEL TANK REMOVAL AND REPLACEMENT (ALL TRUCKS EXCEPT M275A1 AND M275A2).

TOOLS : 5/8-inch wrench
1/2-inch wrench

SUPPLIES : Sealer compound, type II, Mil. Spec S-45180

PERSONNEL : Two

EQUIPMENT CONDITION : Truck parked, engine off, handbrake set.

a. Preliminary Procedures.

(1) Disconnect battery ground cable. Refer to para 7-58.

(2) Drain fuel tank. Refer to TM 9-2320-209-10.

(3) Take fuel lines and electrical connector off in-tank fuel pump. Refer to para 4-8.

b. Removal.

WARNING

Do not permit smoking, sparks or open flame within 50 feet of truck during fuel tank removal. Fuel could explode, causing injury to personnel and damage to equipment.

FRAME 1

1. Using 1/2-inch wrenches, loosen two locknuts (1) on bolts (2) .
2. Using 5/8-inch wrenches, unscrew and take off two locknuts (3) and two bolts (4) .
3. Swing retaining bands (5) down and away from fuel tank (6) .

GO TO FRAME 2

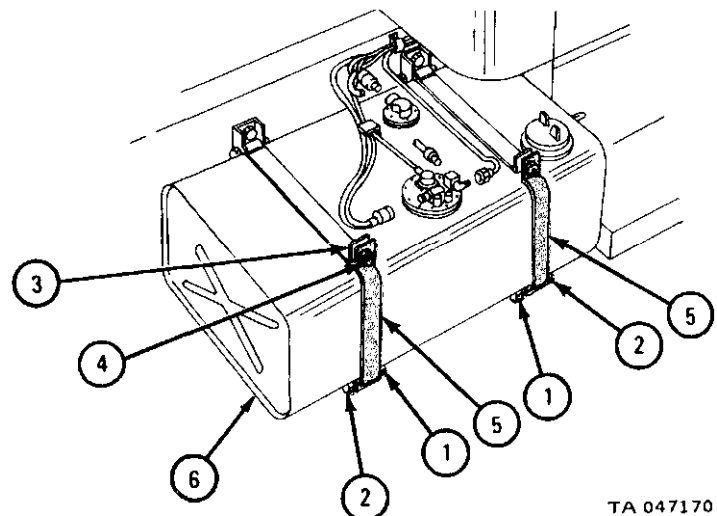
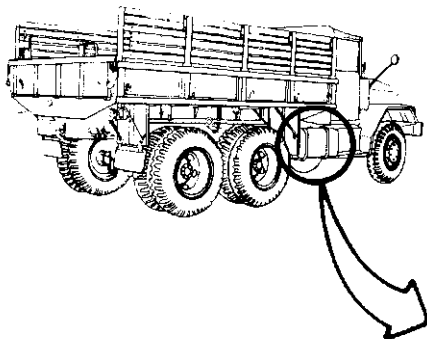

TA 047170

FRAME 2

1. Take connector (1) off sending unit (2).
2. Using 5/8-inch wrench, unscrew tube nut (3) and pull return line (4) away from elbow fitting (5).
3. Slide fuel tank (6) out of brackets (7) and lift tank off truck.

Soldiers
A and B

END OF TASK

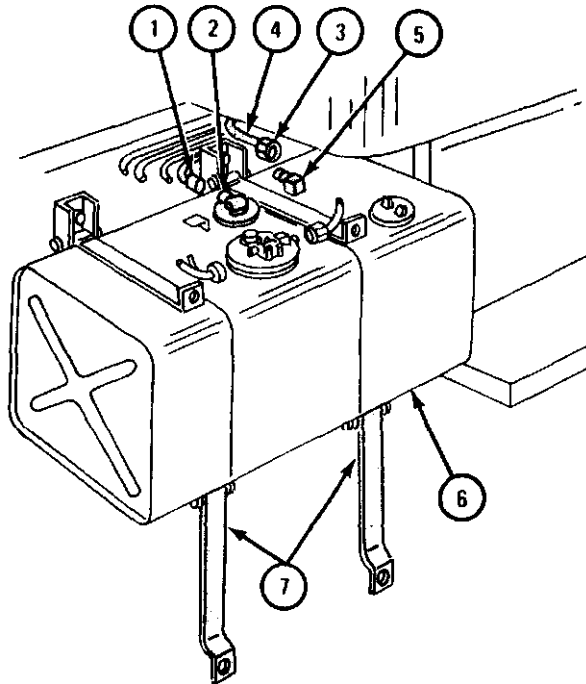

TA 047171

c. Replacement.**WARNING**

Do not permit smoking, sparks or open flame within 50 feet of truck during fuel tank replacement. Fuel could explode, causing injury to personnel and damage to equipment.

FRAME 1

Soldiers 1. Lift fuel tank (1) onto brackets (2) .
A and B

2. Plug connector (3) into sending unit (4) .

NOTE

Put a very thin coat of sealer compound on threads of all fuel line fittings before joining them.

3. Join return line (5) to elbow fitting (6) and screw on tube nut (7) .
Using 5/8-inch wrench, tighten nut.

GO TO FRAME 2

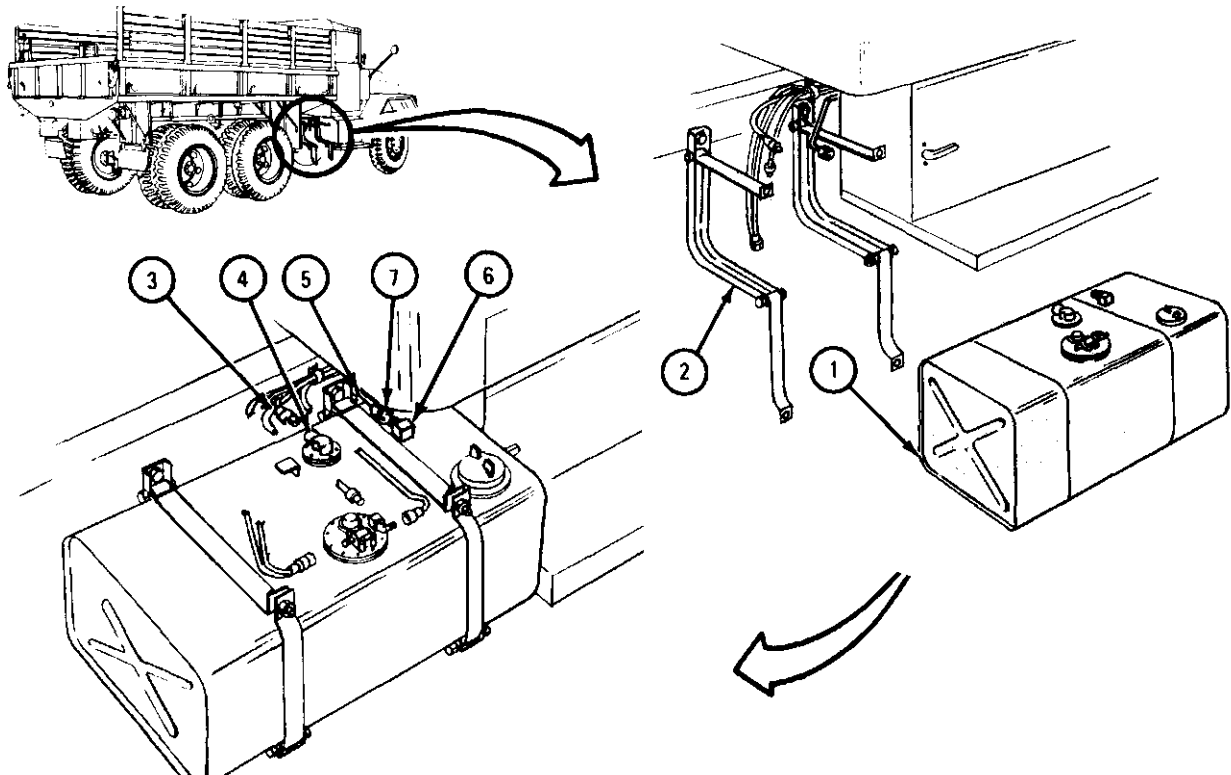

TA 047172

FRAME 2

1. Swing two retaining bands (1) up against fuel tank (2).
2. Join retaining bands (1) to top straps (3) with bolts (4) as shown. Screw locknuts (5) on bolts and tighten using 5/8-inch wrenches.
3. Using 1/2-inch wrenches, tighten two locknuts (6) on bolts (7).

NOTE

Follow-on Maintenance Action Required:

1. Join fuel lines and electrical connector to in-tank fuel pump. Refer to para 4-8.
2. Reconnect battery ground cable. Refer to para 7-58.
3. Fill fuel tank. Refer to TM 9-2320-209-10.
4. Start engine and check fuel line fittings for leaks. Stop engine. Refer to TM 9-2320-209-10.
5. Check operation of fuel gage. Refer to TM 9-2320-209-10.

END OF TASK

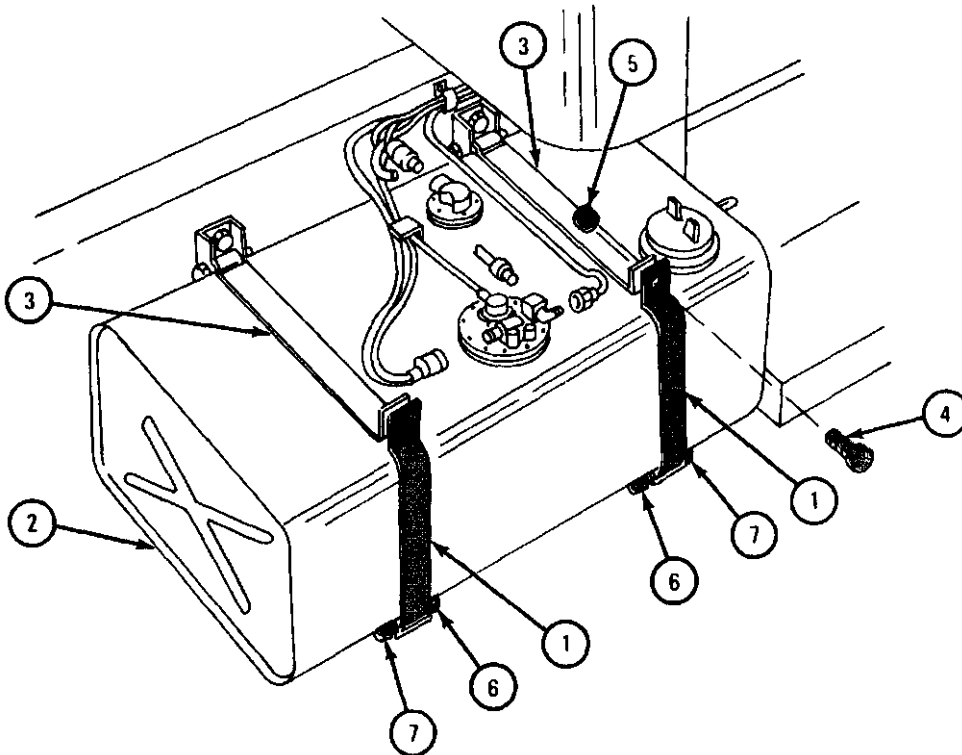

TA 047173

4-7. FUEL TANK REMOVAL AND REPLACEMENT (TRUCKS M275A AND M275A2).

WARNING

Smoking, sparks, or open flame are not allowed within 50 feet of work area during this task. Fuel could explode, causing injury to personnel and damage to equipment.

TOOLS : 1/2-inch wrench (2) 6-inch ruler
 9/16-inch wrench (2) 15/16-inch wrench (2)
 Prybar 3/4-inch wrench (2)
 Wood block, 3/4 x 2 x 12 inches (2) 5-inch extension
 Wood block, 2 x 4 x 12 inches

SUPPLIES : None

PERSONNEL : Two

EQUIPMENT CONDITION : Truck parked, engine off, handbrake set.

a. Preliminary Procedures.

- (1) Disconnect battery ground cable. Refer to para 7-58.
- (2) Drain fuel tank. Refer to TM 9-2320-209-10.
- (3) Take fuel lines and electrical connector off in-tank fuel pump. Refer to para 4-8.

b. Removal.**FRAME 1**

1. Using 1/2-inch wrenches, loosen three locknuts (1) on three screws (2) on bottom of three retaining straps (3).
2. Using 9/16-inch wrenches, unscrew and take off three locknuts (4) and three screws (5) at top of three retaining straps (3).
3. Swing three retaining straps (3) down and away from fuel tank (6).

GO TO FRAME 2

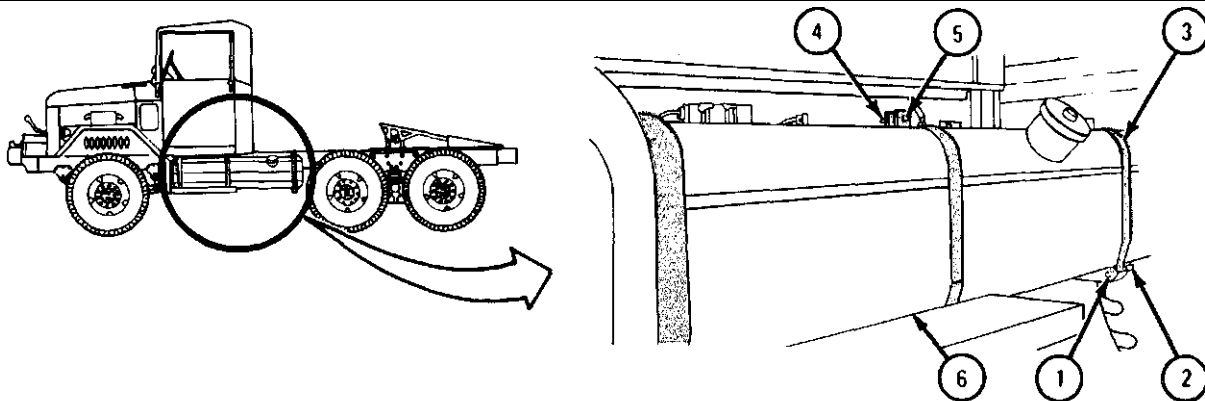

TA 047435

FRAME 2

1. Using 1/2-inch wrench, hold two screws (1) and unscrew and takeoff nuts (2) on forward strap (3) and center strap (4).
 2. Take out two screws (1).
 3. Take off straps (3, 4, and 5).
- GO TO FRAME 3

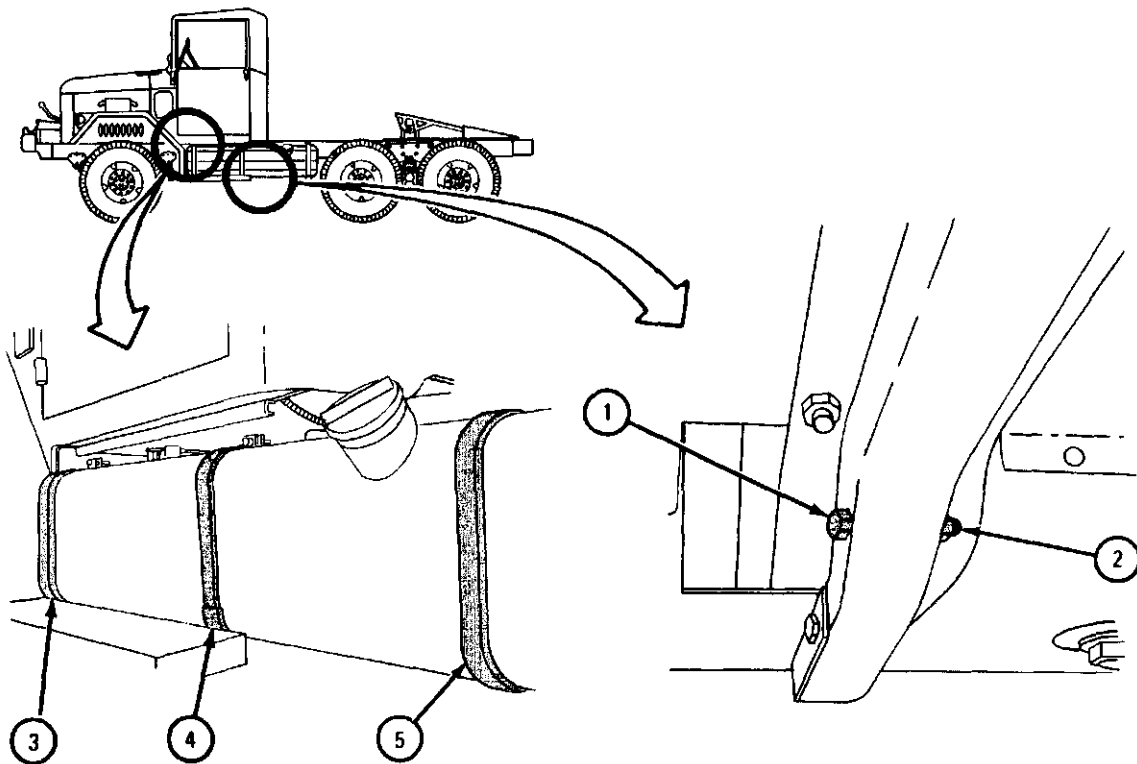

TA 047436

FRAME 3

1. Working under cab rear crossmember (1) using 15/16-inch wrenches, loosen two nuts (2) as much as possible without taking them out.

GO TO FRAME 4

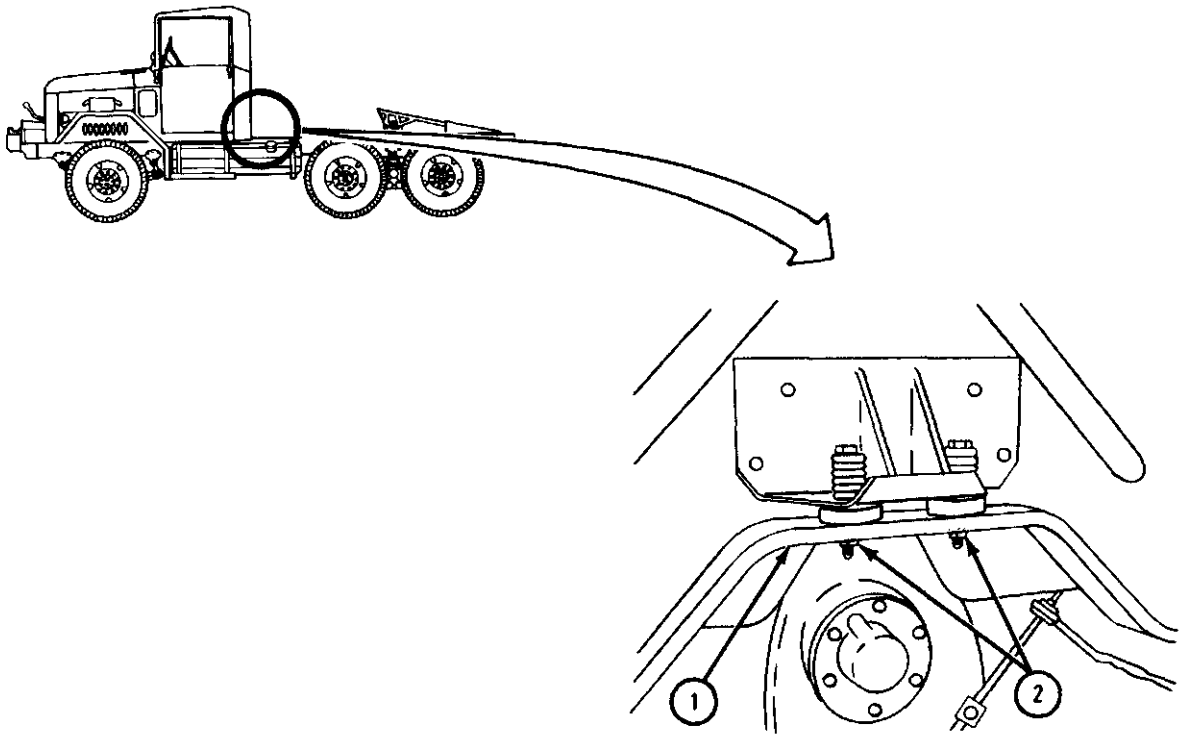

TA 047437

FRAME 4

- Soldier A 1. Using prybar (1) between cab left front sill (2) and frame rail (3) , raise left side of cab (4) about 3/4 inch.
- Soldier B 2. Put 3/4 x 2 x 12-inch wood block (5) between cab left front sill (2) and frame rail (3).
- Soldier A 3. Take out prybar (1) .
- GO TO FRAME 5

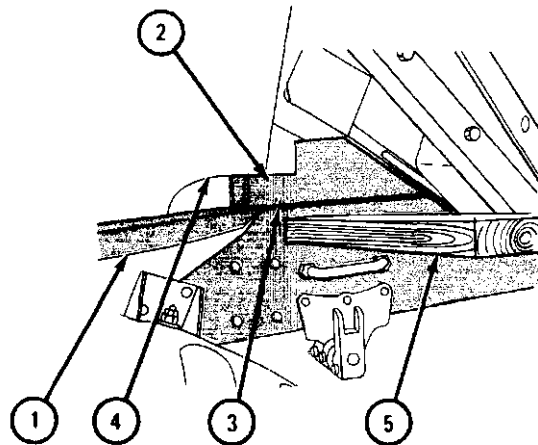
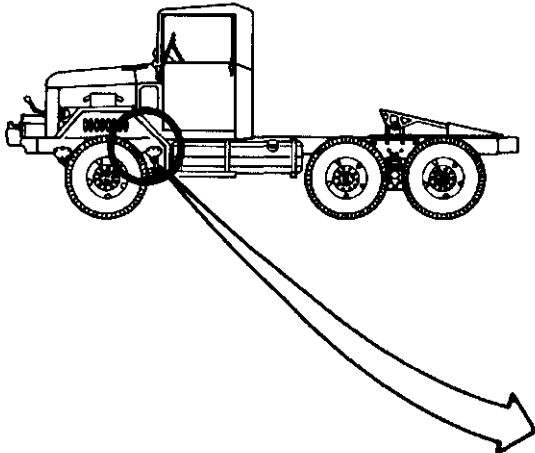

TA 047438

FRAME 5

- Soldier A 1. Using prybar (1) between cab left rear sill (2) and frame rail (3), raise left rear side of cab (4) about two inches.
- Soldier B 2. Put 2 x 4 x 12-inch wood block (5) between cab left rear sill (2) and frame rail (3).
- Soldier A 3. Lower cab left rear sill onto wood block (5) and take out pry bar (1).

GO TO FRAME 6

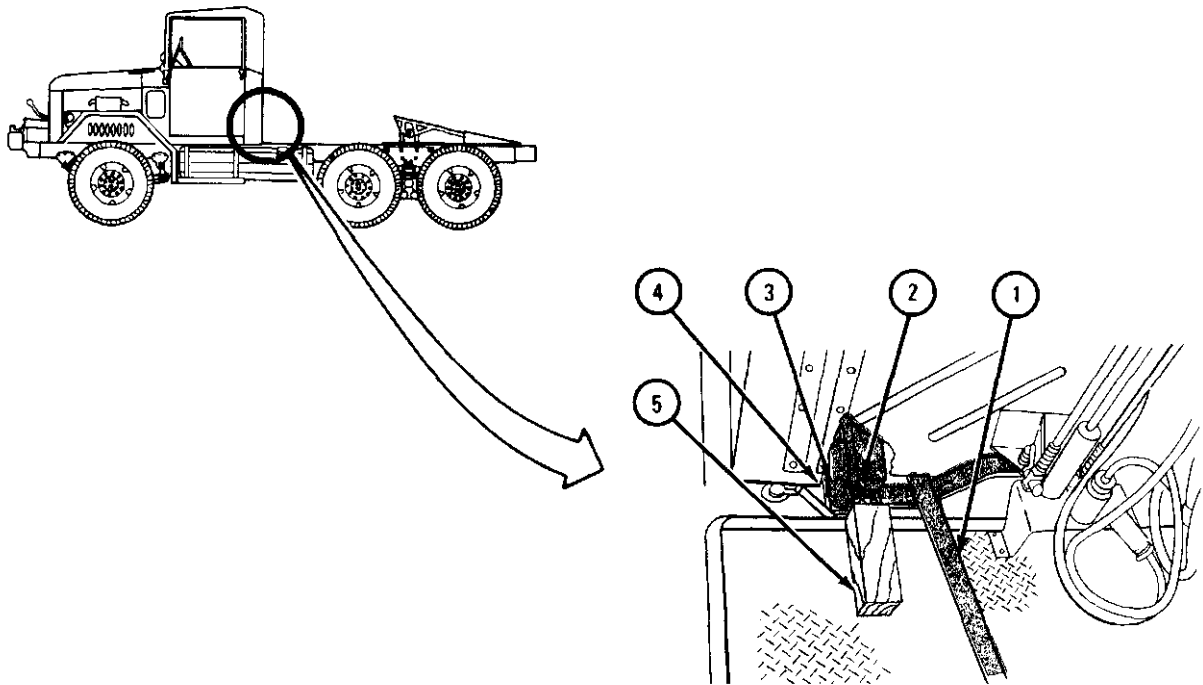

TA 047439

FRAME 6

Soldier A 1. Lift rear end of fuel tank (1) and take it out of rear support bracket (2).

Soldier B 2. Lift front end of fuel tank (1) and push it out of front and center support brackets (3 and 4). Slide fuel tank out toward rear of truck.

END OF TASK

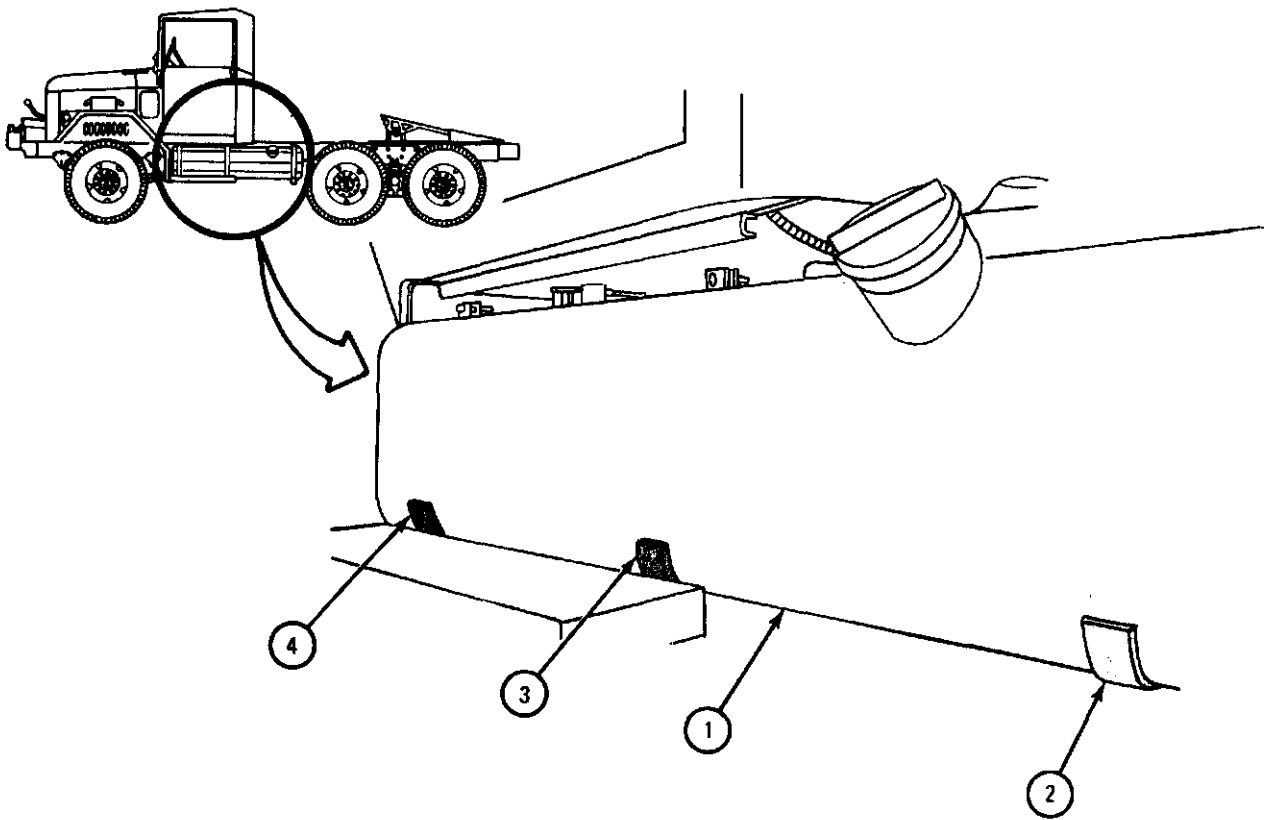

TA 047440

c. Replacement.

FRAME 1

Soldier A 1. Slide front end of fuel tank (1) over running board (2), under cab (3), and onto bracket (4).

Soldier B 2. Slide back end of fuel tank (1) onto rear bracket (5).

CAUTION

Make sure webbing is between rear mounting bracket (5) and fuel tank (1) to prevent damage to tank.

GO TO FRAME 2

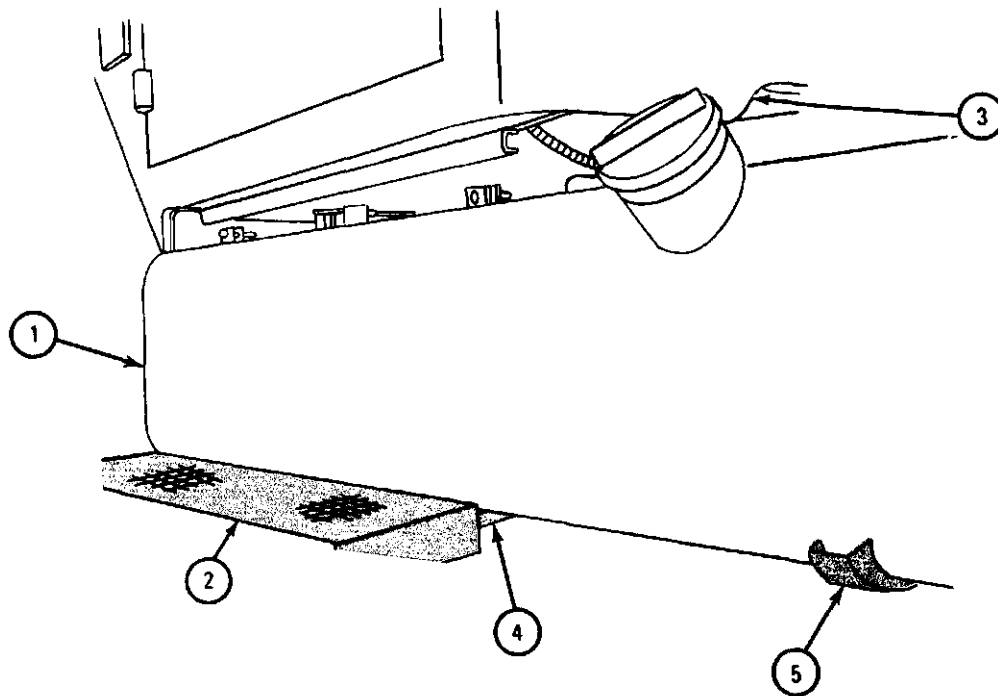

TA 047441

FRAME 2

- Soldier A 1. Using pry bar (1) between cab left rear sill (2) and frame rail (3) , raise left rear of cab (4).
- Soldier B 2. Take wood block (5) out from between cab left rear sill (2) and frame rail (3) .
- Soldier A 3. Lower cab (4) down onto frame rail (3). Take out pry bar (1) .
- GO TO FRAME 3

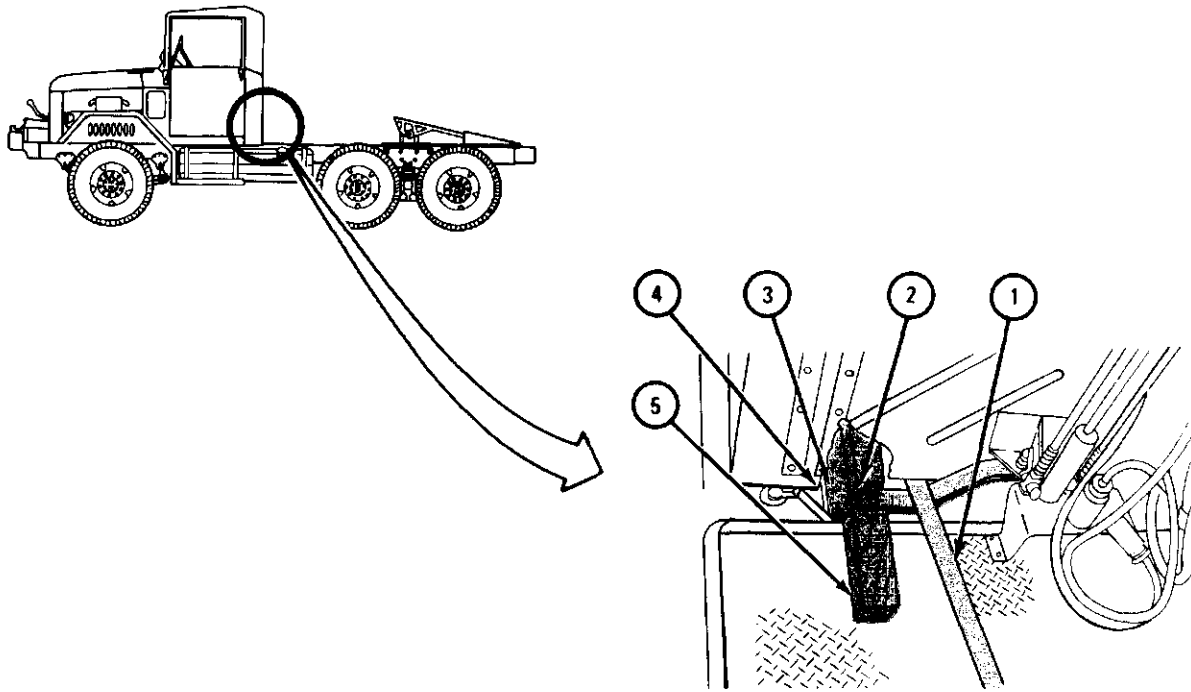

TA 047439

FRAME 3

Soldier A 1. Using prybar (1) between cab left front sill (2) and frame rail (3) , raise left front side of cab (4).

Soldier B 2. Take wood block (5) out from between cab left front sill (2) and frame rail (3) .

Soldier A 3. Lower left side of cab (4) onto frame rail (3). Take out pry bar (1).

GO TO FRAME 4

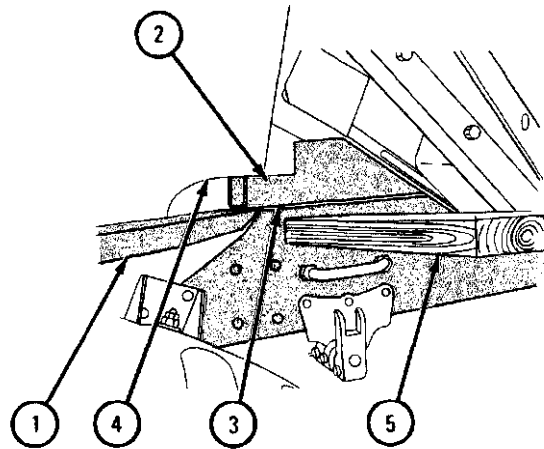
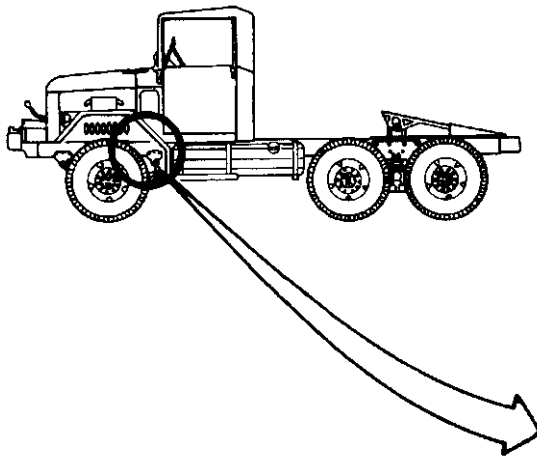

TA 047438

FRAME 4

1. Using 15/16-inch wrenches and 6-inch ruler, hold two cab rear mounting screws (1) and tighten two nuts (2) until springs (3) are compressed to 1 25/32 inches.

GO TO FRAME 5

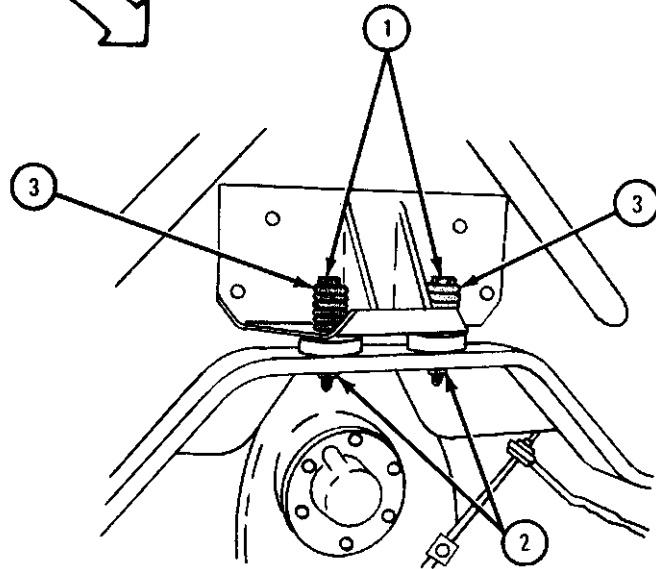
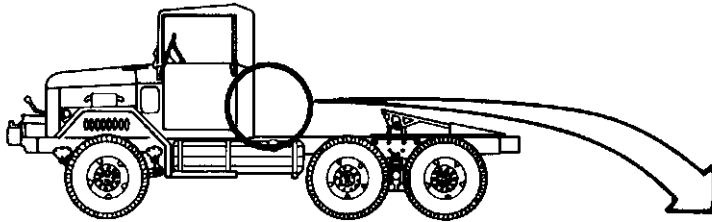

TA 047443

FRAME 5

1. Put forward strap (1), center strap (2), and rear strap (3) in brackets (4).
2. Put two screws (5) through holes in brackets (4) and bottom of straps (1 and 2).
3. Screw on and hand tighten nuts (6) on screws (5).

GO TO FRAME 6

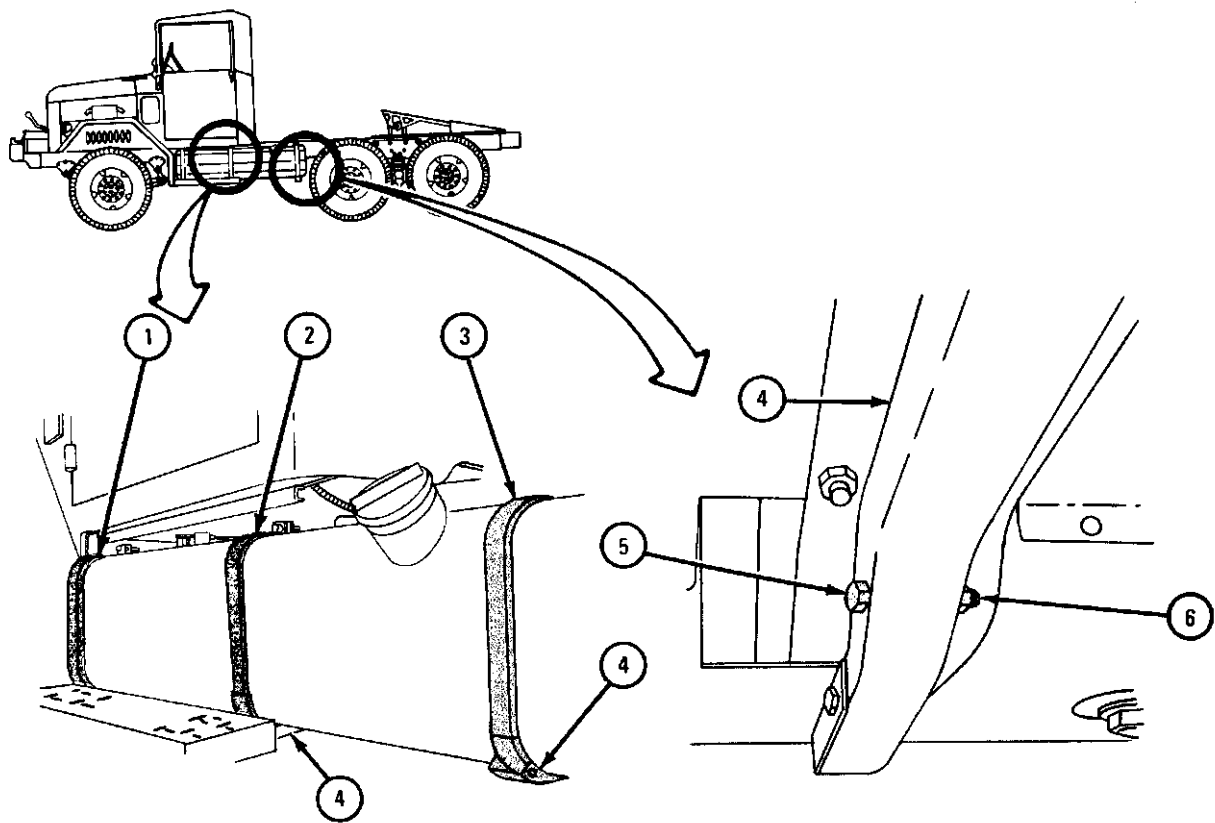

TA 047444

FRAME 6

CAUTION

Make sure webbing is between hold down straps and fuel tank to prevent damage to tank.

1. Swing three side hold down straps (1) into place.
2. Aline holes in three side hold down straps (1) with holes in three top hold down straps (2) .
3. Put three screws (3) through holes in side and top hold down straps (land 2).
4. Screw on three locknuts (4) to screws (3).
5. Using 9/16-inch wrenches, hold three screws (3) and tighten three nuts (4).

GO TO FRAME 7

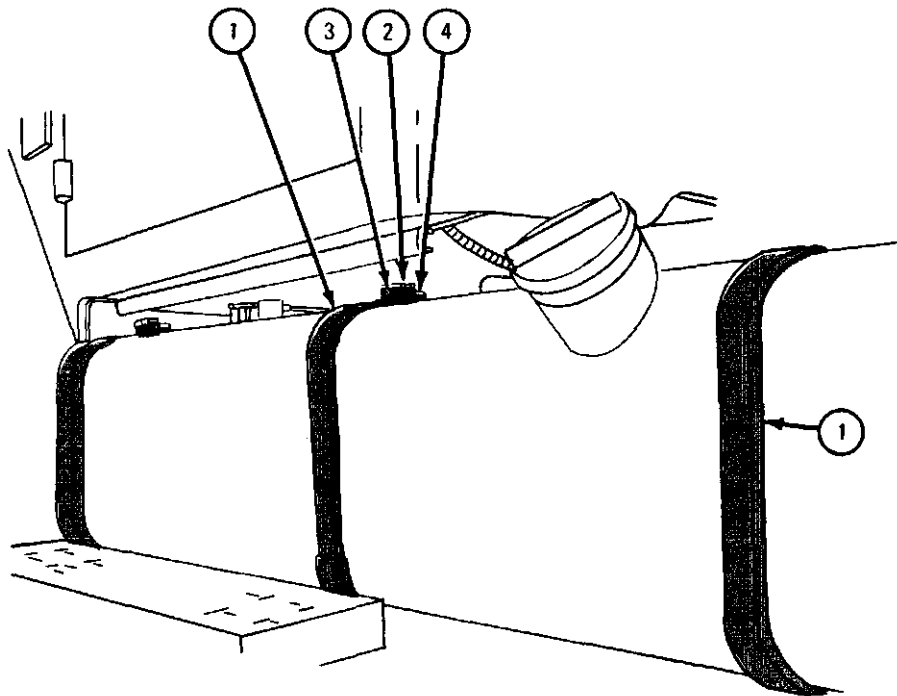

TA 047445

FRAME 7

1. Using 1/2-inch wrenches, hold screws (1) on forward, center, and rear straps (2) and tighten nuts (3) .

NOTE

Follow-on Maintenance Action Required:

1. Join fuel lines and electrical connectors to in-tank fuel pump. Refer to para 4-8.
2. Reconnect battery ground cable. Refer to para 7-58.
3. Fill fuel tank. Refer to TM 9-2320-209-10.
4. Start engine and check fuel line fittings for leaks. Stop engine. Refer to TM 9-2320-209-10.
5. Check operation of fuel gage. Refer to TM 9-2320-209-10.

END OF TASK

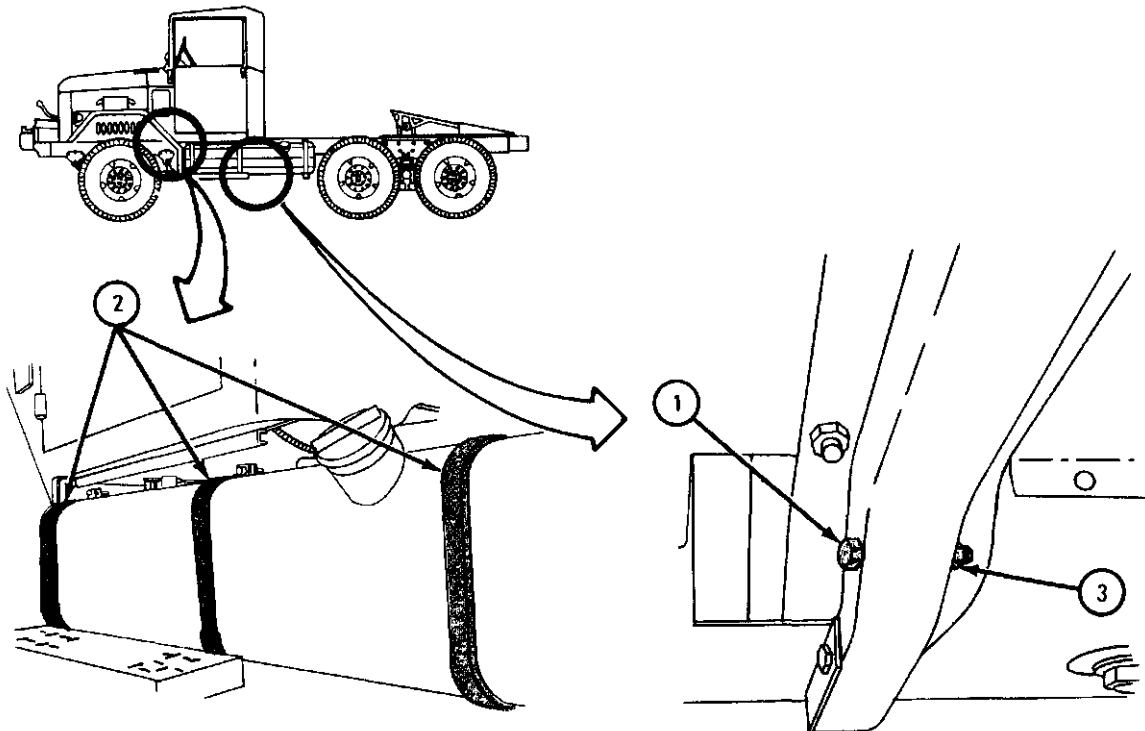

TA 047446

4-8. FUEL PUMP (IN-TANK) REMOVAL AND REPLACEMENT.

TOOLS : Flat-tip screwdriver
7/16-inch wrench
3/4-inch wrench
3/8-inch wrench
Tape measure

SUPPLIES : Solvent, dry cleaning, type II (SD-2), Fed. Spec P-D-680
Sealer compound, type II, MIL-S-45180

PERSONNEL: One

EQUIPMENT CONDITION: Truck parked, engine off, handbrake set.

WARNING

Do not permit smoking, sparks or open flame within 50 feet of truck during fuel pump removal. Fuel could explode, causing injury to personnel and damage to equipment.

a. Preliminary Procedures.

(1) On trucks M756A2, M275A1, and M275A2, fuel tank must be moved out several inches to replace in-tank fuel pump. Refer to para 4-6 and para 4-7.

(2) Disconnect battery ground cable. Refer to para 7-58.

b. Removal.

FRAME 1

1. Take electrical connector (1) off fuel pump receptacle (2).
2. Using 3/8-inch wrench, unscrew heater line coupling nut (3) from elbow (4).

NOTE

Some trucks may not have heater fuel line. If not, pipe plug replaces elbow.

3. Using 3/4-inch wrench, unscrew feed line coupling nut (5) from fuel pump tee fitting (6).

GO TO FRAME 2

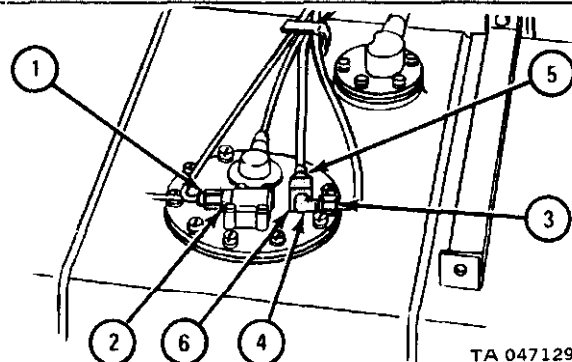
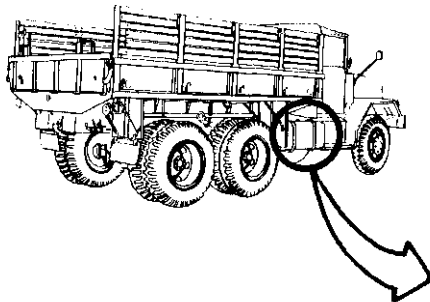

TA 047129

FRAME 2

1. Using 3/8-inch wrench, unscrew vent line coupling nut (1) from elbow (2).
2. Using 7/16-inch wrench, unscrew elbow (2).
3. Using screwdriver, unscrew 10 mounting screws (3) and take off 10 lockwashers (4).
4. Carefully lift fuel pump (5) out of tank. Do not scrape pump against edges of hole. Throw gasket (6) away.

CAUTION

Cover hole in tank to prevent dirt and moisture from getting into fuel system.

END OF TASK

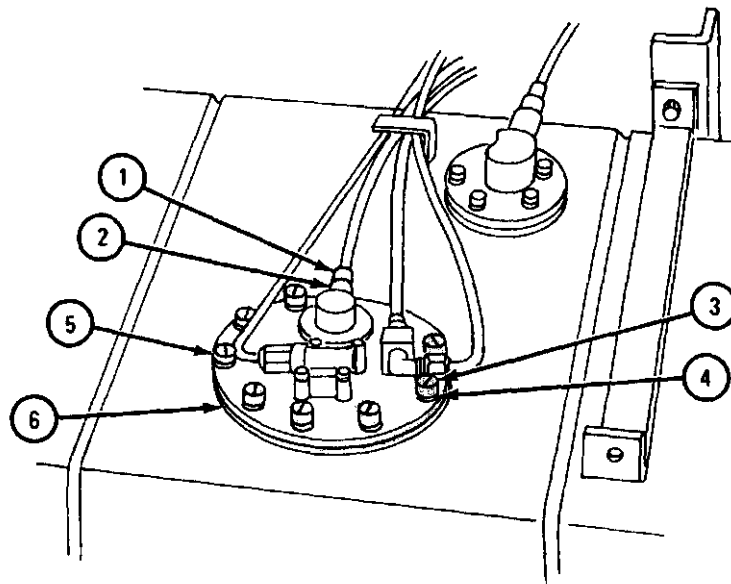

TA 047130

c. Replacement.

WARNING

Do not permit smoking, sparks or open flame within 50 feet of truck during fuel pump replacement. Fuel could explode, causing injury to personnel and damage to equipment.

NOTE

Put a very thin coat of sealer compound on threads of all fuel line fittings before installing.

FRAME 1

1. If new fuel pump is being put in, unscrew and take off elbow (1). Using 7/16-inch wrench, screw in and tighten elbow removed from old pump into new pump.

NOTE

Pump depth measurement A shown must be 14 3/16 inches for truck models M275A1, M275A2, and M342A2. For all other truck models, measurement A must be 15 3/16 inches.

If necessary to adjust pump depth, do steps 2 through 4.

2. Using screwdriver and 7/16-inch wrench, unscrew and take off two screws, lockwashers, and nuts (2). Move pump (3) up or down in brackets (4).
3. Use set of mounting holes in brackets which will position pump (3) to meet measurement A.
4. Put back two screws, lockwashers and nuts (2) and tighten using screwdriver and 7/16-inch wrench.

GO TO FRAME 2

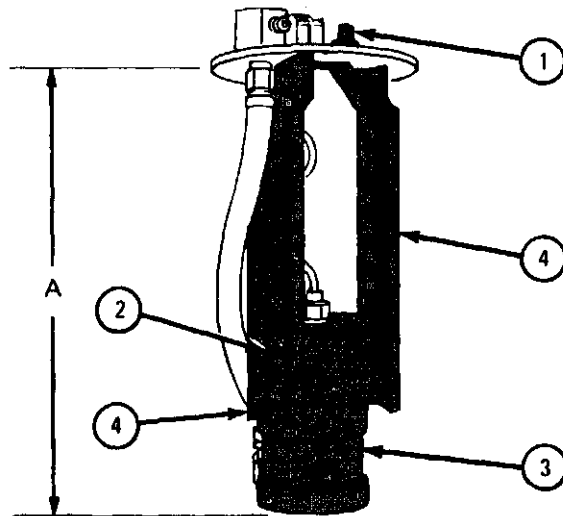

FRAME 2

WARNING

Dry cleaning solvent is flammable. Do not use near an open flame. Keep a fire extinguisher nearby when solvent is used. Use only in well-ventilated places. Failure to do this may result in injury to personnel and damage to equipment.

1. Take off protective cover from hole in tank. Clean mating flanges of fuel pump and tank with dry cleaning solvent. Apply thin coat of sealer compound to threads of fuel fittings before assembling.
2. Put new gasket (1) on fuel tank (2) and aline 10 holes.

CAUTION

Be very careful when putting fuel pump in tank so that electrical cable shield will not scrape hole. Damage to the shield could cause electrical failure.

3. Put fuel pump (3) in tank (2) as shown. Aline holes in pump with holes in gasket (1) and tank (2) .
4. Using screwdriver, screw in and tighten 10 screws (4) with 10 lockwashers (5) through holes in pump mounting flange.

GO TO FRAME 3

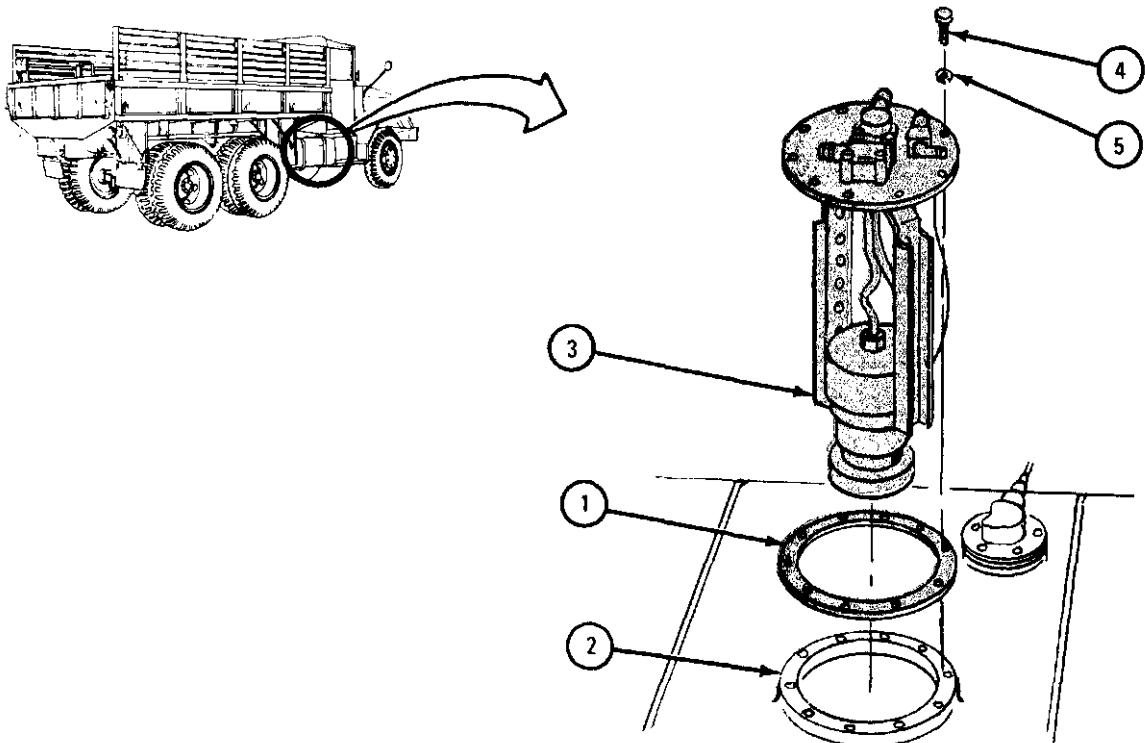

TA 047132

FRAME 3

NOTE

Some trucks may not have heater fuel line. If not, pipe plug replaces elbow.

1. Using 3/8-inch wrench, screw in and tighten heater line coupling nut (1) to elbow (2).
2. Using 3/4-inch wrench, screw in and tighten feed line coupling nut (3) into tee fitting (4).
3. Using 7/16-inch wrench, screw in and tighten vent line elbow (5) in place as shown.
4. Using 3/8-inch wrench, screw in and tighten vent line coupling nut (6) into elbow (5).
5. Plug electrical connector (7) into receptacle (8).

NOTE

Follow-on Maintenance Action Required:

1. Reconnect battery ground cable. Refer to para 7-58.
2. Bleed low pressure fuel system. Refer to para 4-10.
3. Test in-tank fuel pump operation. Refer to TM 9-2320-209-10.

END OF TASK

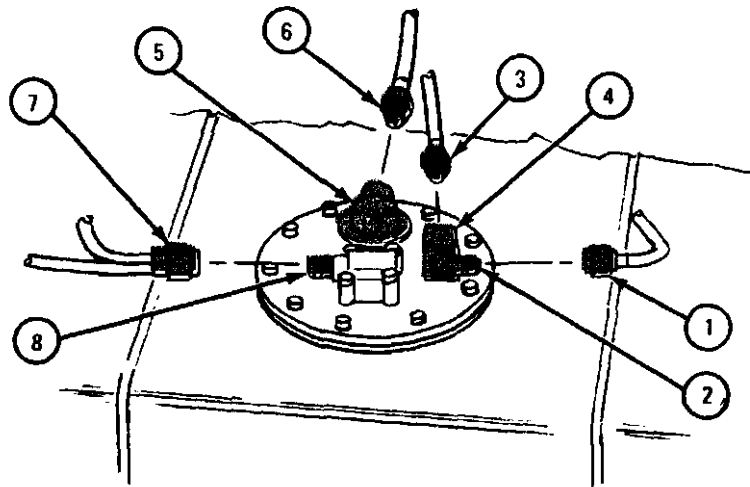

TA 047133

4-8.1 FUEL PUMP (IN-TANK) BRACKET AND PUMP ASSEMBLY REPAIR.

TOOLS: 7/16-inch wrench

5/8-inch wrench

3/4-inch wrench

1/2-inch wrench

Phillips screwdriver

SUPPLIES: Wire seal

Terminal cover gasket

PERSONNEL: One

EQUIPMENT CONDITION: Truck parked, parking brake set, engine off.

- a. preliminary procedures.

WARNING

Be careful when using cleaning solutions and solvents. Do not expose skin to solvents or inhale their vapors. Many cleaning agents are toxic and contact with them or their vapors may cause illness or death. Wear protective clothing and devices and ensure adequate ventilation while using cleaning agents.

NOTE

After disassembly and before inspection, clean metal parts in clean diesel fuel or drycleaning solvent. Carefully blow out and dry each part with compressed air.

- (1) Battery ground cable disconnected. Refer to para. 7-58.
- (2) Fuel tank removed. Refer to para. 4-6.
- (3) Fuel pump (in-tank) removed. Refer to para. 4-8.
- (4) Inspect pump for cracks, distortion and warpage.
- (5) Inspect cable for cuts, damage and continuity.
- (6) Inspect tube assembly for cracks and other evidence of excessive wear in tube and for damage to swivel end.
- (7) Check continuity of ground cable and inspect for cuts and other damage.
- (8) Inspect welded and support parts for cracks, distortion and breakage.

- (9) Inspect threaded parts for nicks, cross threading and excessive wear.
- (10) Inspect polarizing pin, terminal pin assembly, connector housing and pin assembly and fuse block for nicks, cracks, distortion and other damage that would impair their use.
- (11) Inspect other terminal assembly components for tears, cracks, hardening and other damage that would impair their use.
- (12) Replace pump and electric cable assembly if continuity check of cable shows it to be grounded or if there is any evidence of damage that would impair its use.
- (13) Repair dents or distortions. Weld cracks and breaks in metal parts where practical. Replace defective parts if badly damaged.
- (14) Repair threaded parts with a thread chaser if practical or replace defective parts.
- (15) Replace any other defective parts.

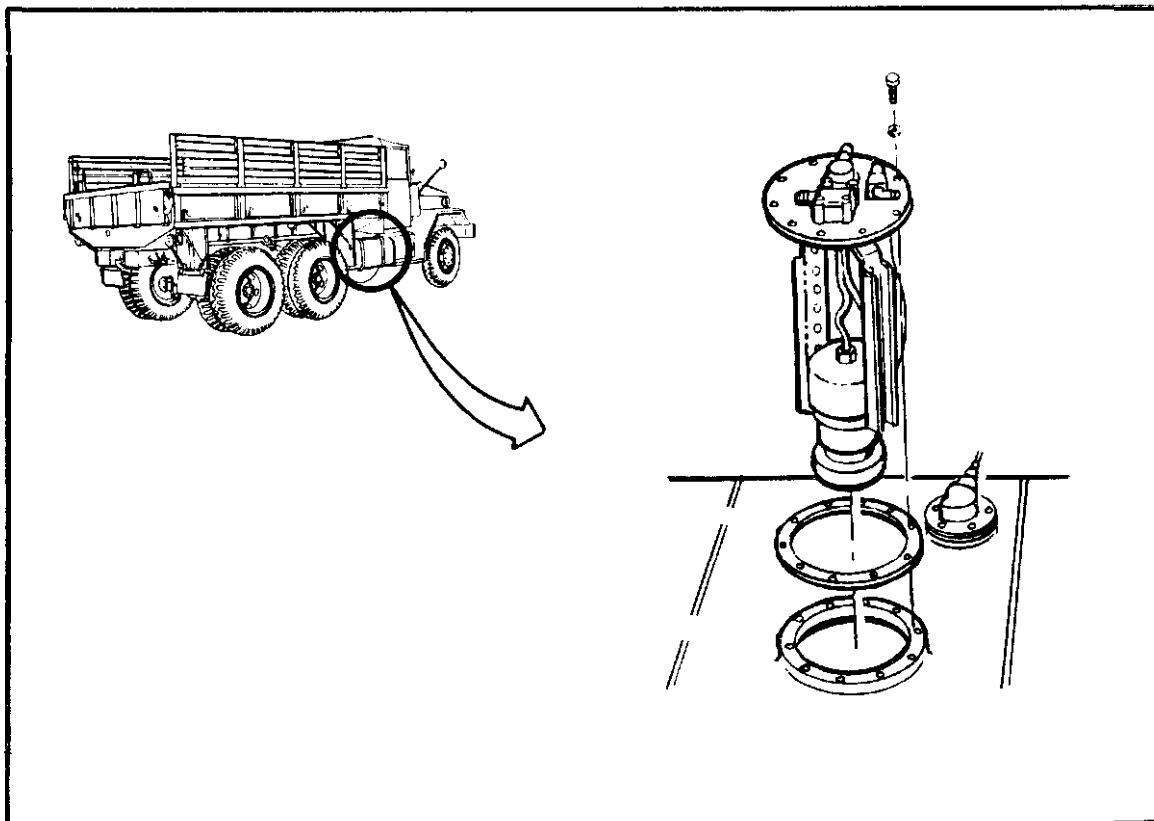

b. Removal

FRAME 1

1. Remove lead seal (1) by cutting wire. Discard lead seal (1).
 2. Remove three nuts (2) and lockwashers (3), metal tab (4) (if present), and terminal cover (5) from plate and bracket (6). Discard lockwashers (3).
 3. Remove screw (7) and disconnect pump wire (8) from terminal cover (5).
 4. Remove nut (9), washer (10) and gasket (11) from fuel pump wire (8). Discard gasket (11) and washer (10).
 5. Remove fuse (12) from terminal cover (5).
 6. Remove elbow (13) from plate and bracket (6).
 7. Remove fitting (14) and "O" ring (15) from plate and bracket (6).
- GO TO FRAME 2

NOTE

Record location of mounting hardware for proper installation.

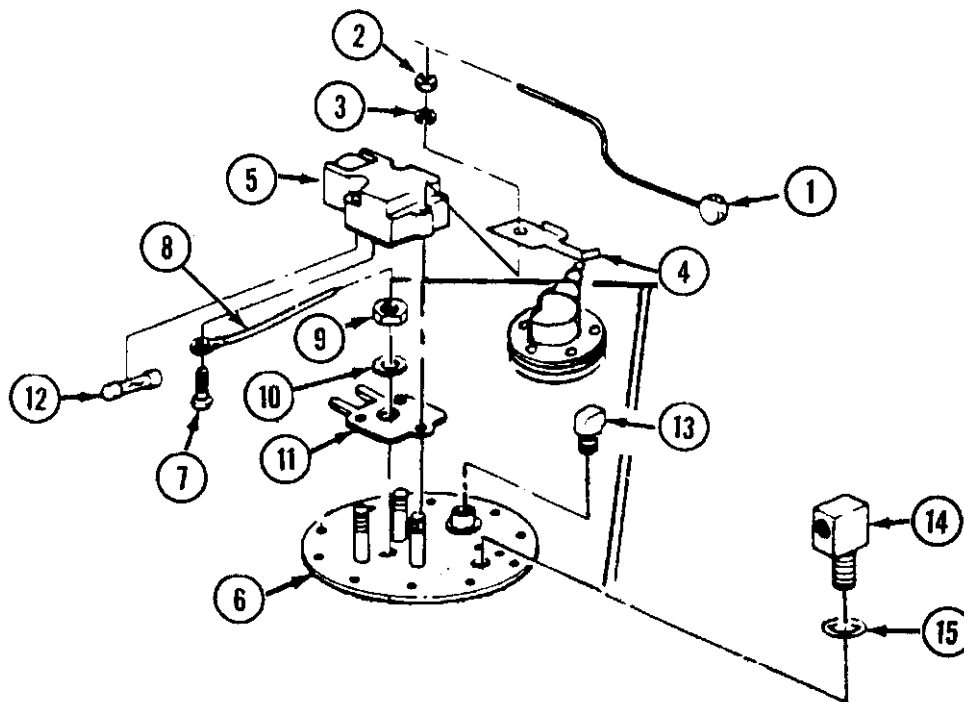

FRAME 2

1. Remove three nuts (1), washers (2), screws (3), clamp (4) and pump (5) wire from plate and bracket (6) and clamp assembly (7).
2. Remove recessed washer (8) and gasket (9) from pump (5) wire.
3. Remove hose assembly (10), nut (11) and washer (12) from plate and bracket (6).
4. Remove clamp (13) and hose assembly (10) from pump (5).
5. Remove nut (14), lockwasher (15), strap assembly (16), lockwasher (15), and screw (17) from pump (5). Discard lockwashers (1 5).

END OF TASK.

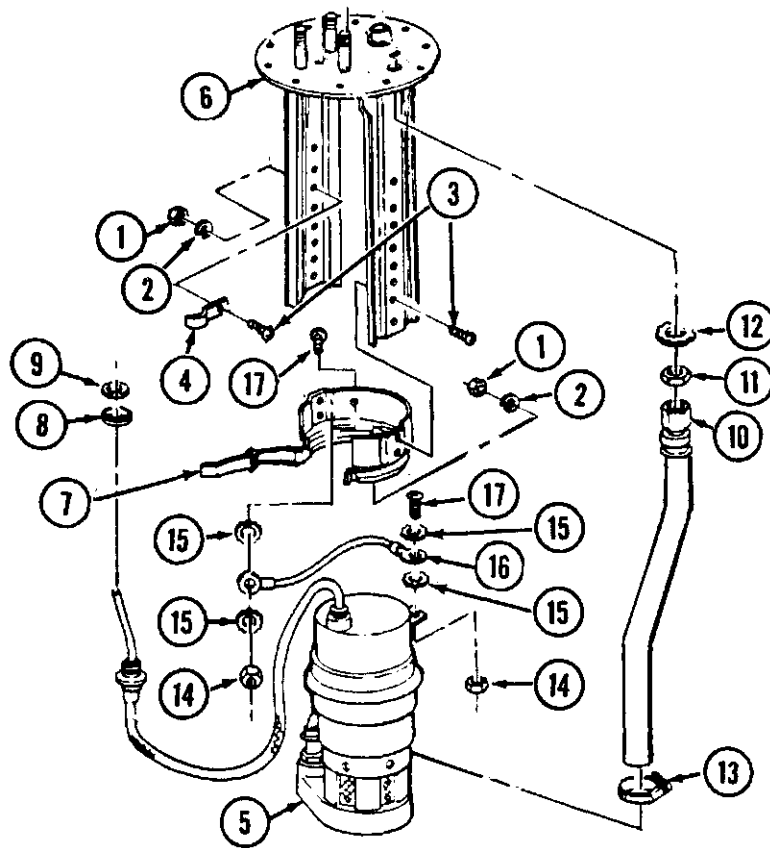

c. Replacement.

FRAME 1

1. Secure one end of strap assembly (1) to pump (2) with screw (3), two lockwashers (4) and nut (5).
2. Secure the other end of strap assembly (1) to clamp assembly (6) with screw (3), two lockwashers (4) and nut (5).
3. Install one end of hose assembly (7) on pump (2) and secure with clamp (8).
4. Install recessed washer (9) and gasket (10) on pump (2) wire.
5. Connect clamp assembly (6) to plate and bracket (19) with two screws (11), washers (12) and nuts (13).
6. Route pump (2) wire through plate and bracket (19) and secure with screw (11), clamp (14), washer (12) and nut (13).
7. Install "O" ring (15) on fitting (16).
8. Put threaded end of fitting (16) through hole on plate and bracket (19) and secure with washer (17) and nut (18).

GO TO FRAME 2

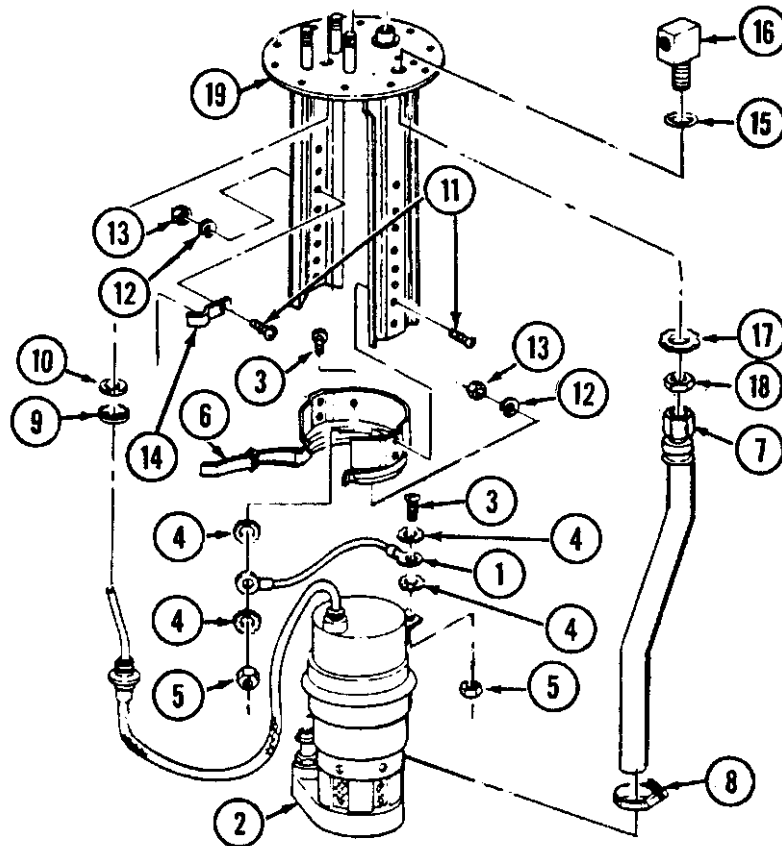

FRAME 2

1. Connect threaded end of hose (1) to threaded end of fitting (2).
2. Install elbow (3) on plate and bracket (4).
3. Position gasket (5) over fuel pump (6) wire coming through plate and bracket (4) and secure wire to plate and bracket (4) with washer (7) and nut (8).
4. Connect fuel pump (6) wire to terminal assembly (9) with screw (10) and install VA fuse (11) in terminal assembly (9).
5. Install terminal assembly (9) and tab (12) (if available) on three studs of plate and bracket (4). Secure with three lockwashers (13) and nuts (14).
6. Install seal (15) and secure seal (15) by bending tab (12).

NOTE
Follow-on Maintenance Action Required.

7. Install fuel pump assembly. Refer to paragraph 4-8.
8. Install fuel tank. Refer to paragraph 4-6.
9. Connect battery ground cable. Refer to paragraph 7-58.
10. Check fuel pump for proper operation.

END OF TASK

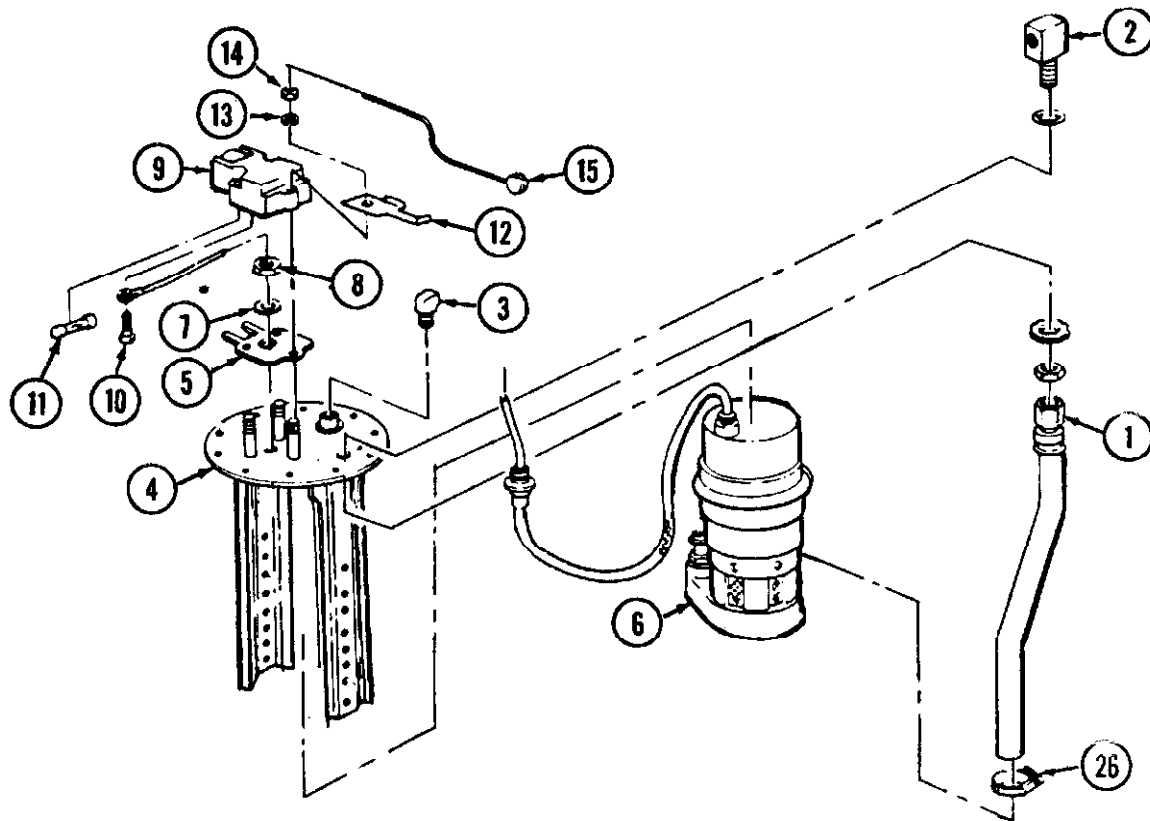

4-9. FUEL PUMP (IN-TANK) FUSE REMOVAL AND REPLACEMENT.

TOOLS : 7/16-inch wrench
 Flat-tip screwdriver
 Diagonal pliers, small
 Lead seal press

SUPPLIES : 2-ampere automotive fuse
 Lead seal with wire
 Gasket

PERSONNEL : One

EQUIPMENT CONDITION : Truck parked, engine off, handbrake set.

NOTE

On tractor models M275A1 and M275A2, fuel tank must be moved to gain access to in-tank fuel pump fuse. Refer to para 4-7.

a. Removal.

FRAME 1

1. Using pliers, cut wire on metallic seal tab (1) . Take off and throw away seal and wire.
2. Using 7/16-inch wrench, unscrew four nuts (2) and take off nuts and four lockwashers (3).

NOTE

Some pumps use three nuts (2).

3. Lift terminal cover (4) off pump (5) and position as shown.
4. Using screwdriver, unscrew terminal screw (6) and lift off pump wire (7).

GO TO FRAME 2

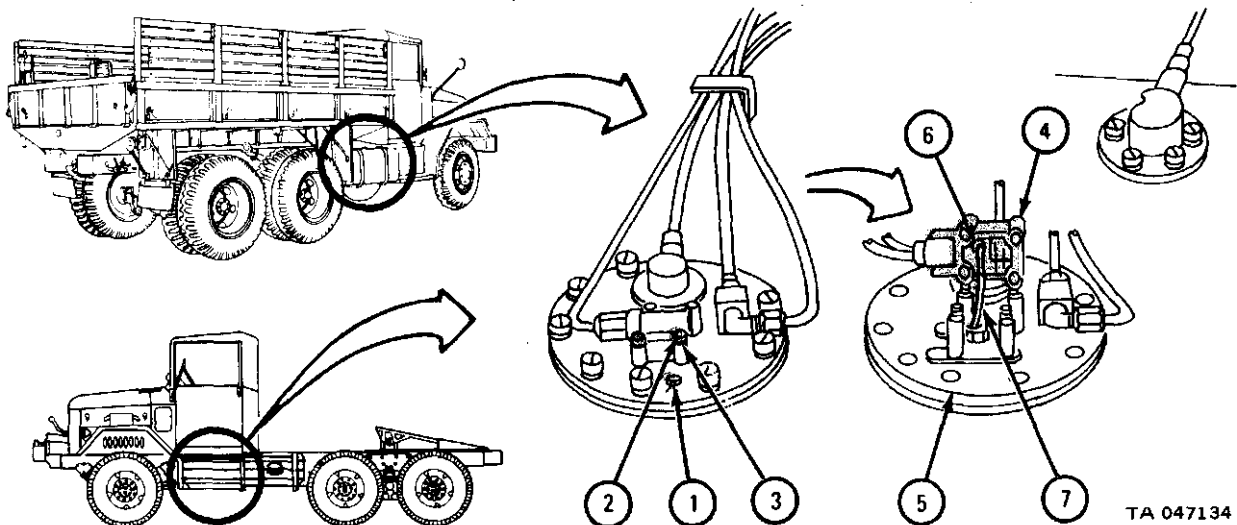

FRAME 2

1. Lift gasket (1) off mounting studs (2) and throw gasket away.
2. Lift fuse (3) out of holder (4).

END OF TASK

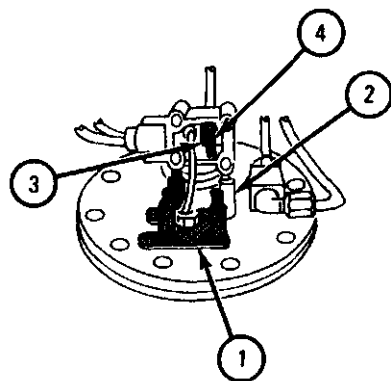

TA 047135

b. Replacement.

FRAME 1

WARNING

Make sure that replacement fuse is 2 amperes. Higher ampere fuse could cause fuel to explode if pump overheats.

1. Put 2-ampere fuse (1) in holder (2).
2. Put gasket (3) over pump wire (4) and three mounting studs (5) .
3. Put pump wire (4) on terminal (6). Using screwdriver, screw in and tighten screw (7) .

GO TO FRAME 2

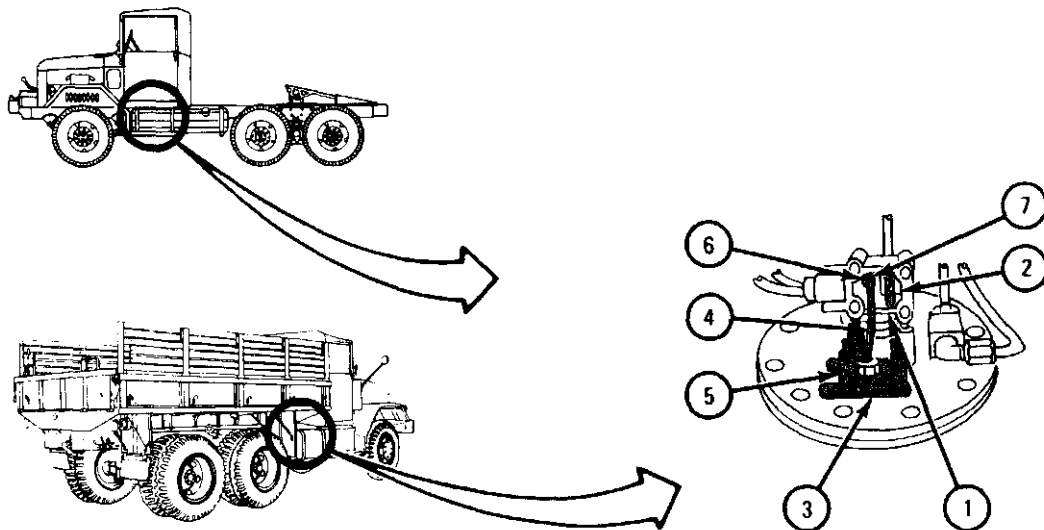

TA 047136

FRAME 2

1. Put cover (1) over four studs (2) and seat cover firmly on gasket (3).

NOTE

Some pumps use three studs (2) to mount terminal cover(1).

2. Put four lockwashers (4) on studs (2) and screw on four nuts (5). Using wrench, tighten nuts.
3. Thread end of wire on metallic seal (6) through hole in end of one stud (2). Thread end of wire back into metallic seal and squeeze seal using lead seal press.
4. Join connector (7) to receptacle (8).

NOTE

Follow-on Maintenance Action Required:

Start truck and let engine run. Refer to TM 9-2320-209-10.

END OF TASK

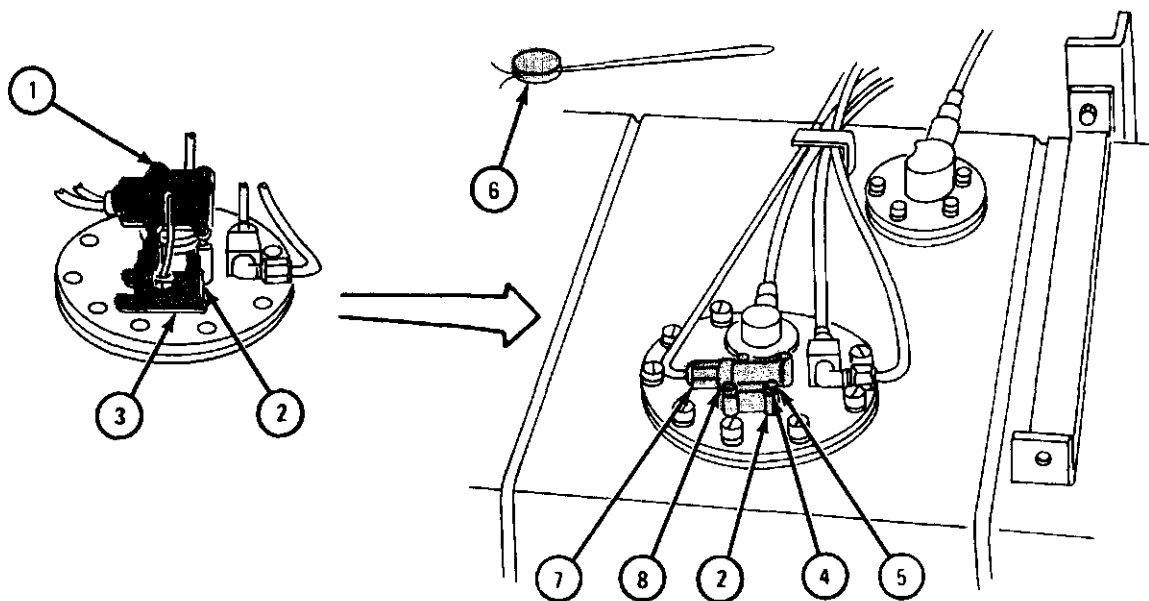

TA 047137

Section IV. FUEL FILTER

4-10. FUEL FILTER ASSEMBLIES REMOVAL , REPLACEMENT, AND AIR BLEEDING .

TOOLS : 3/4-inch wrench 7/16-inch wrench
 9/16-inch wrench 11/16-inch wrench
 5/8-inch wrench

SUPPLIES : Diesel fuel container, 5-gallon capacity
 Rags

PERSONNEL : One

EQUIPMENT CONDITION : Truck parked, engine off, handbrake set.

Preliminary Procedure. Open hood and both side panels. Refer to TM 9-2320-209-10.

b. Removal of Primary Fuel Filter Assembly.

WARNING

To prevent fire or explosion, smoking, flame, sparks, and glowing or hot objects are not allowed near truck during maintenance of fuel system components.

FRAME 1

1. Place container under drain cock (1) . Unscrew (open) drain cock. Screw in drain cock when all fuel stops draining.
2. Using 3/4-inch wrench, unscrew two coupling nuts (2) and pull two fuel lines (3 and 4) out of two fittings (5 and 6) .
3. Take out container and put fuel in approved disposal area.

GO TO FRAME 2

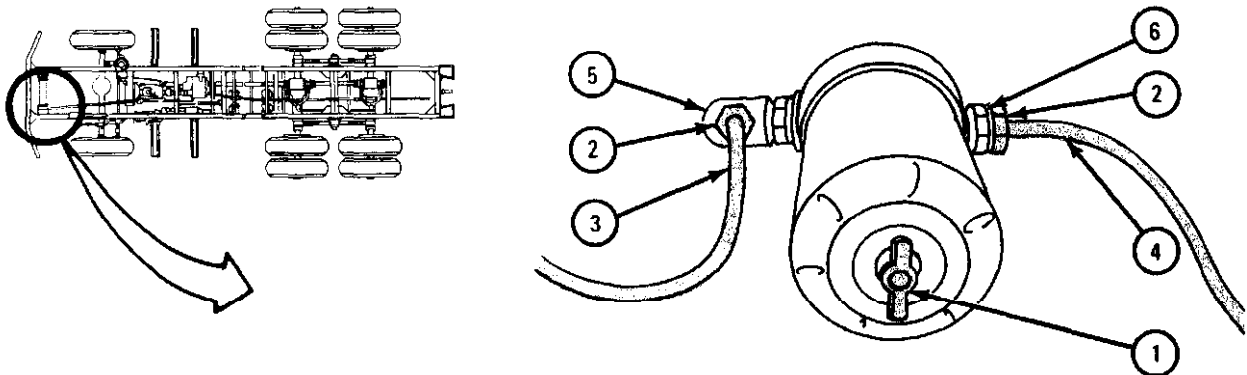

TA 047511

FRAME 2

1. Using 9/16-inch wrench, unscrew and take off four screws and lockwashers (1). Take off primary fuel filter assembly (2).

END OF TASK

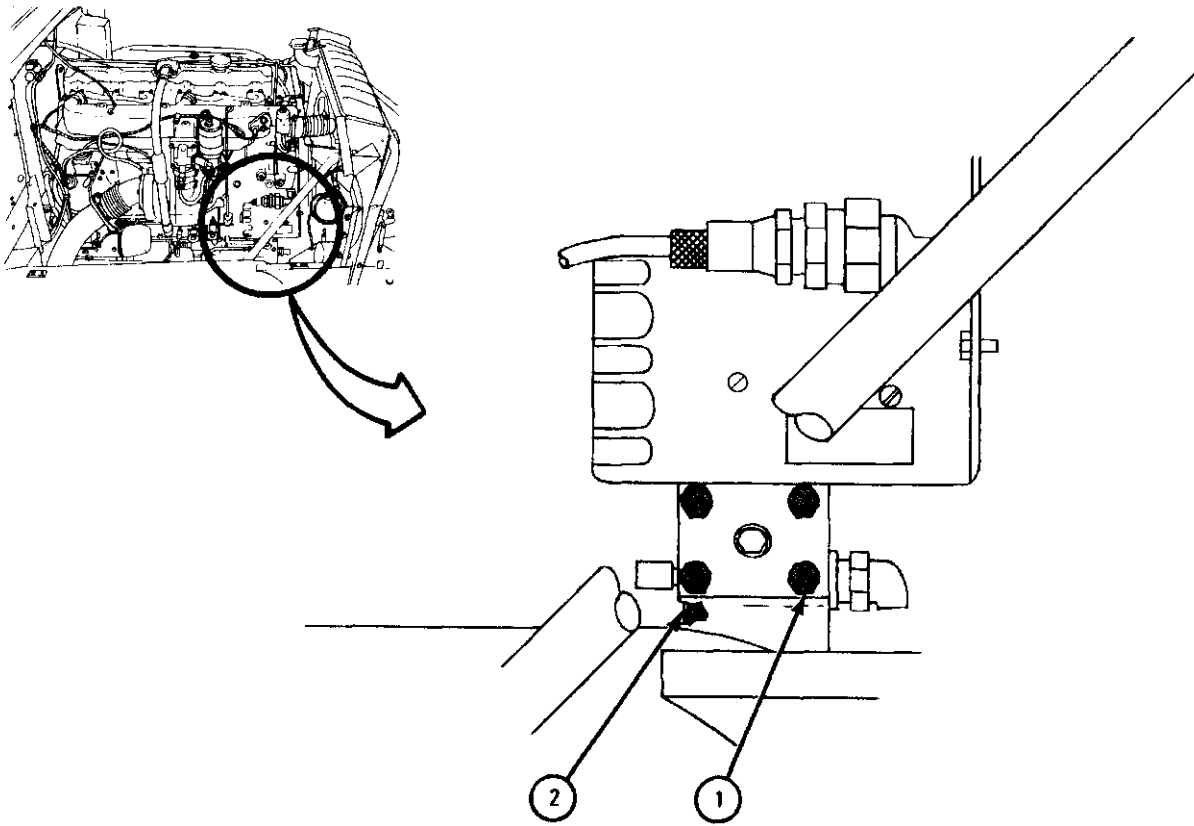

TA 080952

c. Removal of Secondary and Final Fuel Filter Assemblies.

WARNING

To prevent fire or explosion, smoking, flame, sparks, and glowing or hot objects are not allowed near truck during maintenance of fuel system components.

FRAME 1

1. Place container under two drain cocks (1) . Unscrew (open) both drain cocks . Screw in drain cock when all fuel stops draining.

NOTE

Tag fuel lines before taking them off so they will be put back in same place.

2. Using 5/8-inch wrench, unscrew three coupling nuts (2).
3. Using 11/16-inch wrench, unscrew coupling nut (3).
4. Take off fuel lines (4, 5, 6, and 7) .
5. Using 9/16-inch wrench, unscrew and take off three nuts and lockwashers (8).
6. Take off secondary and final fuel filter assemblies (9) .
7. Take out container and put fuel in approved disposal area.

END OF TASK

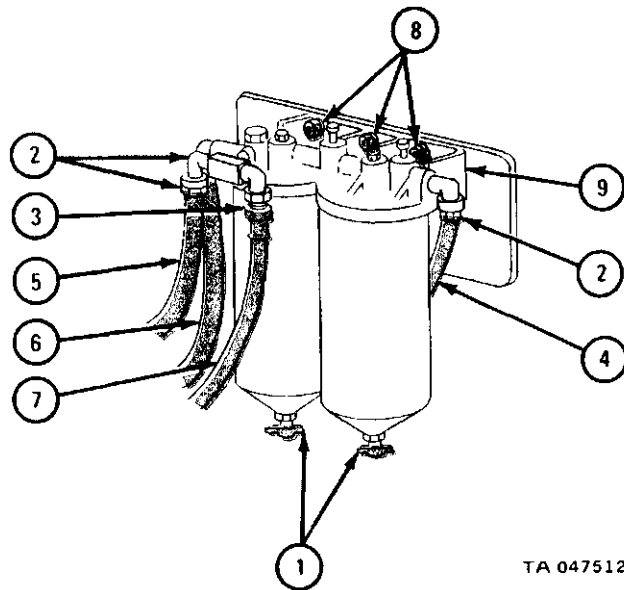
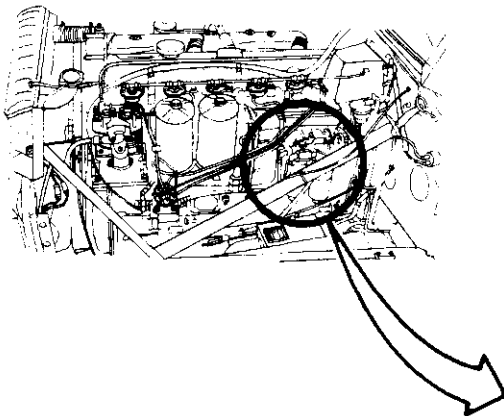

TA 047512

d. Replacement of Primary Fuel Filter Assembly.

FRAME 1

1. Place primary fuel filter assembly (1) against underside of bracket (2) and align four holes.
 2. Using 9/16-inch wrench, screw in and tighten four screws with lockwashers (3)
- GO TO FRAME 2

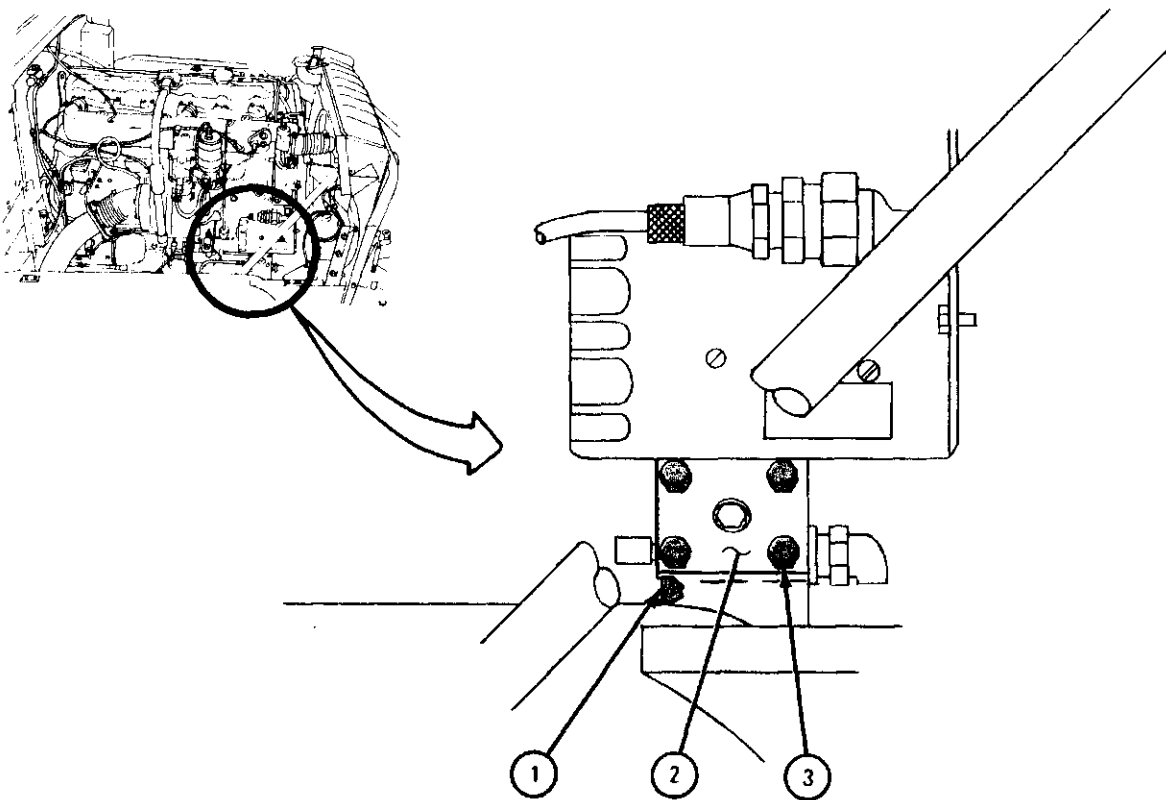

TA 047513

FRAME 2

1. Join two fuel lines (1 and 2) to two fittings (3 and 4). Screw on two coupling nuts (5).
2. Using 3/4-inch wrench, tighten two coupling nuts (5).
3. If only primary fuel filter assembly is being changed, air bleed low pressure fuel system. Refer to para 4-10f.

END OF TASK

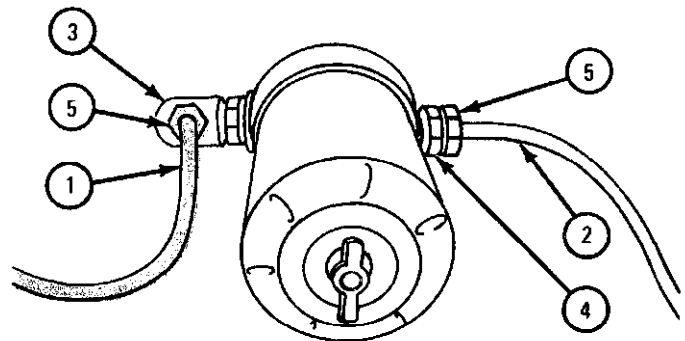
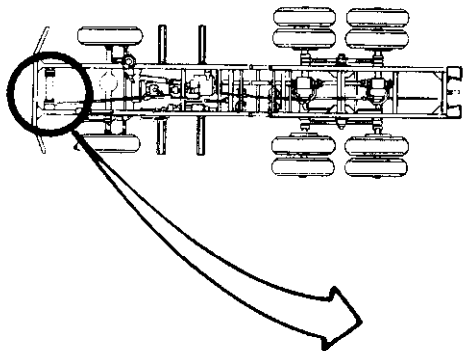

TA 080953

e. Replacement of Secondary and Final Fuel Filter Assemblies.

FRAME 1

1. Place secondary and final fuel filter assemblies (1) on three studs (2).
2. Using 9/16-inch wrench, screw on and tighten three nuts with lockwashers (3)
3. Join fuel lines (4, 5, 6, and 7) as tagged to four elbows (8).
4. Using 5/8-inch wrench, screw on and tighten three coupling nuts (9).
5. Using 11/16-inch wrench, screw on and tighten coupling nut (10). Take off tags.
6. Air bleed low pressure fuel system. Refer to para 4- 10f.

END OF TASK

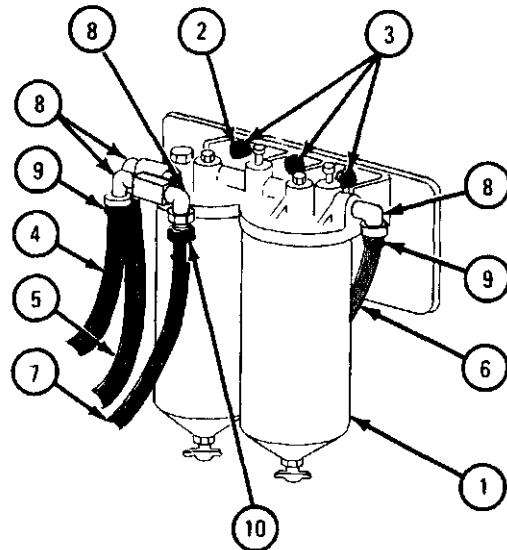
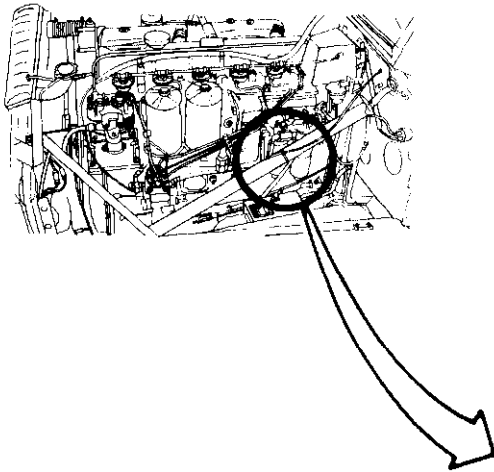

TA 047514

f. Air Bleeding of Low Pressure Fuel System.

FRAME 1

1. Turn accessory switch (1) on instrument panel to ON to operate in-tank fuel pump. Do not start engine at this time.

GO TO FRAME 2

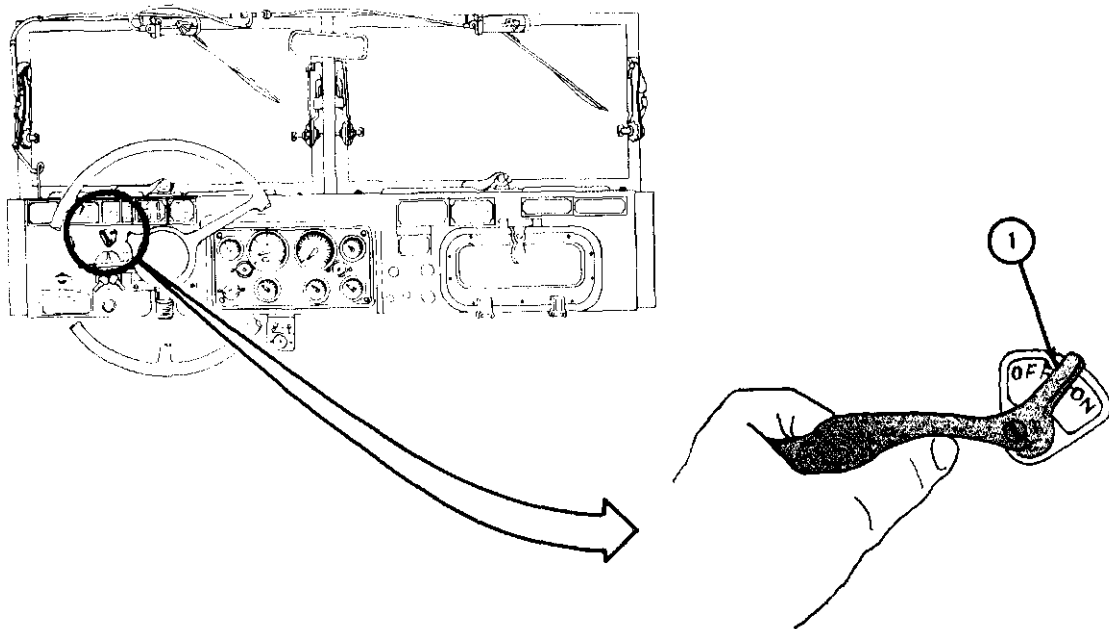

TA 047012

FRAME 2

1. Place container under fuel filters (1 and 2) to catch fuel.

NOTE

Some trucks have only one bleeder valve on the filters, but task is done the same way.

2. Using 7/16-inch wrench, loosen bleeder valve (3) on secondary fuel filter (1). When fuel starts to flow out of bleeder valve, close valve.
3. Using 7/16-inch wrench, loosen bleeder valve (4) on final fuel filter (2). When fuel starts to flow out of bleeder valve, close valve.
4. Open and close bleeder valves (3 and 4) in turn, until fuel is clear of air bubbles.
5. Start engine. Refer to TM 9-2320-209-10.
6. With engine running, open and close bleeder valves (3 and 4) in turn until fuel is clear of air bubbles.
7. Using 7/16-inch wrench, tighten bleeder valves (3 and 4) . Shut off engine. Refer to TM 9-2320-209-10.
8. Using rags, wipe both fuel filters clean of fuel.

NOTE

Follow-on Maintenance Action Required:

Close hood and both side panels. Refer to TM 9-2320-260-10.

END OF TASK

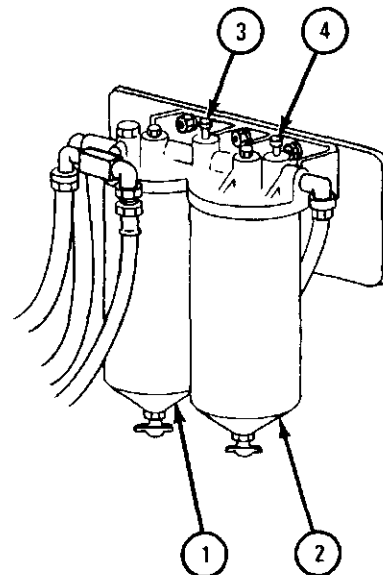
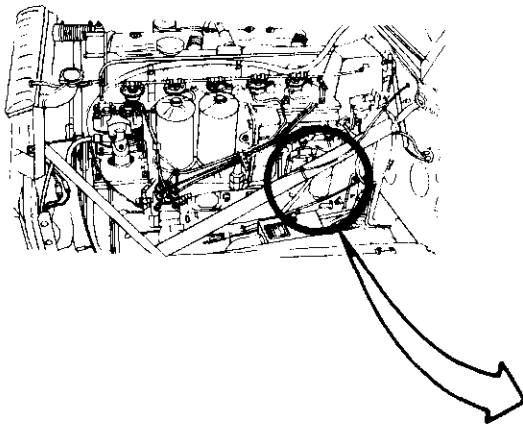

TA 047013

4-11. FUEL FILTERS REPAIR.

TOOLS : 1 7/16-inch wrench 7/16-inch wrench
 7/8-inch wrench 9/16-inch wrench
 Torque wrench, 200 pound- 5/8-inch wrench
 inches capacity
 Long nose pliers

SUPPLIES : Solvent, dry cleaning, type II (SD-2) , Fed. Spec P-D-680
 Fuel filter kit (for primary fuel filter)
 Fuel filter kit (for secondary or
 final fuel filter)
 Container

PERSONNEL: One

EQUIPMENT CONDITION : Truck parked, engine off, handbrake set.

- a. Preliminary Procedure. Take fuel filters out of truck. Refer to para 4-10.
- b. Disassembly of Primary Fuel Filter.

FRAME 1

NOTE

Before taking off fittings (1 and 2) , note their positions so they will be put back at same angles.

1. Using 7/8-inch wrench, unscrew and take off two fittings (1 and 2) .
2. Using 1-inch wrench, unscrew and take off sleeve nut (3) and gasket (4) .
 Throw away gasket (4) .
3. Take off filter housing (5) and throw away filter head gasket (6) .
4. Lift out filter element (7) and throw it away.

GO TO FRAME 2

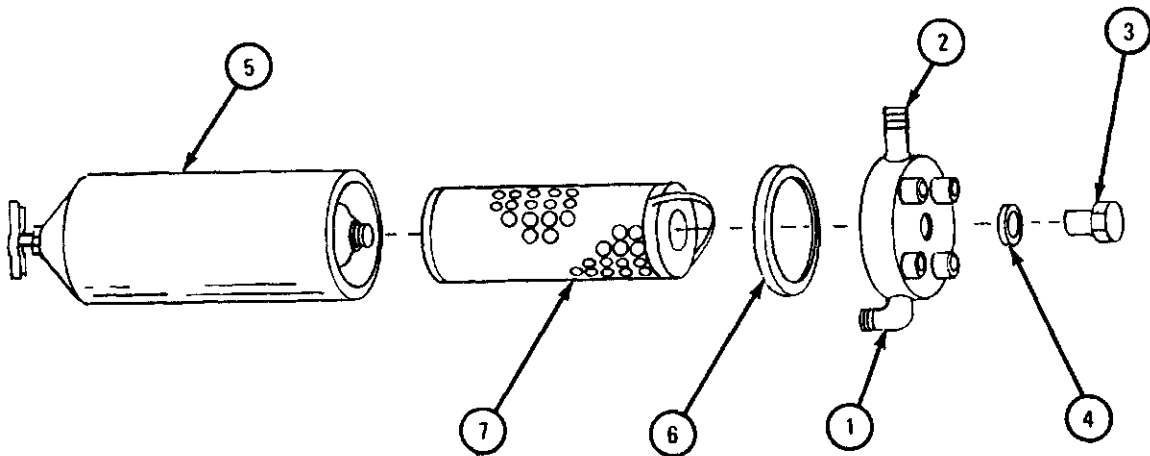

TA 047006

FRAME 2

1. Take off cup (1), gasket (2), washer (3), spring (4), and washer (5).
Throw away gasket.
 2. Using 7/16-inch wrench, unscrew and take out drain cock (6),
- END OF TASK

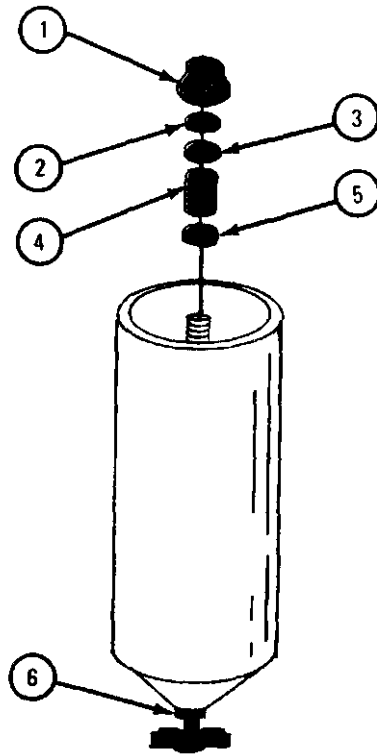

TA 047007

c. Disassembly of Secondary and Final Fuel Filters,

NOTE

This task is the same for secondary fuel filter and final fuel filter. This task is shown for final fuel filter.

FRAME 1

NOTE

Before taking off elbows (1) , note their positions so they will be put back at same angles.

Some trucks may have only one bleeder valve (3).

1. Using 9/16-inch wrench, unscrew and take off three elbows (1).
2. Using 5/8-inch wrench, unscrew and take off elbow (2).
3. Using 7/16-inch wrench, unscrew and take off two bleeder valves (3).
4. Using 9/16-inch wrench, unscrew and take off drain cock (4).
5. Using 5/8-inch wrench, unscrew and take off sleeve nut (5) , washer (6) , and gasket (7). Throw away washer and gasket.
6. Take off filter housing (8) , and throw away filter head gasket (9).

GO TO FRAME 2

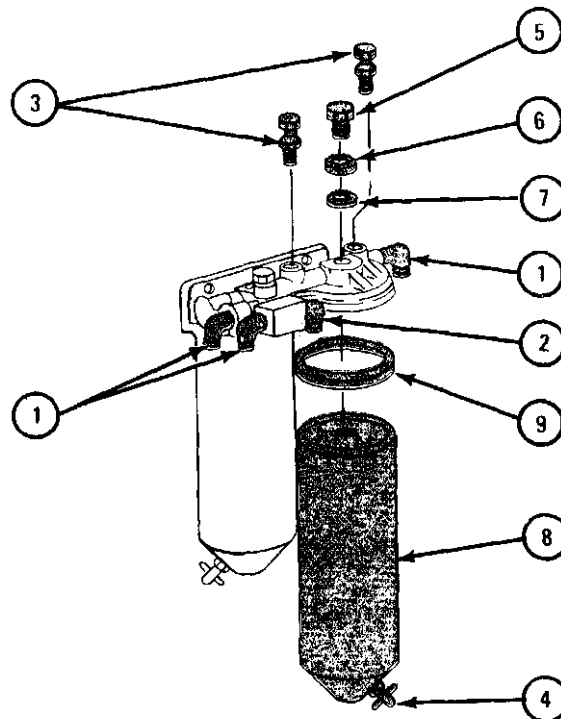

TA 047008

FRAME 2

1. Lift filter element (1) out of filter housing (2) and throwaway filter element.
 2. Press down on cup (3) and, using long nose pliers, take cotter pin (4) out of post (5). Throw away cotter pin.
 3. Take off cup (3), gasket (6), washer (7), and spring (8). Throw away gasket.
- END OF TASK

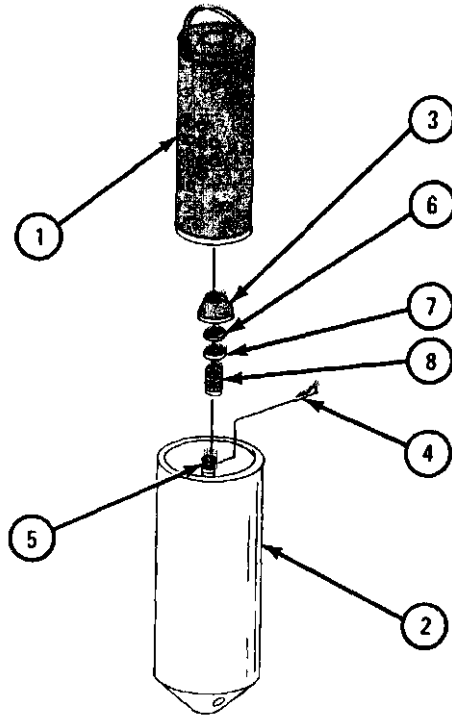

TA 047009

WARNING

Dry cleaning solvent is flammable. Do not use near an open flame. Keep a fire extinguisher nearby when solvent is used. Use only in well-ventilated places. Failure to do this may result in injury to personnel and damage to equipment.

d. Cleaning, Inspection, and Repair. Clean all parts with solvent. Check parts for burrs, nicks, and scratches on mating surfaces. Put in new parts for damaged or bent parts.

e. Assembly of Primary Fuel Filter.

FRAME 1

1. Put washer (1), spring (2), washer (3), gasket (4), and cup (5) on post (6) as shown.
 2. Using 7/16-inch wrench, screw in and tighten drain cock (7) .
- GO TO FRAME 2

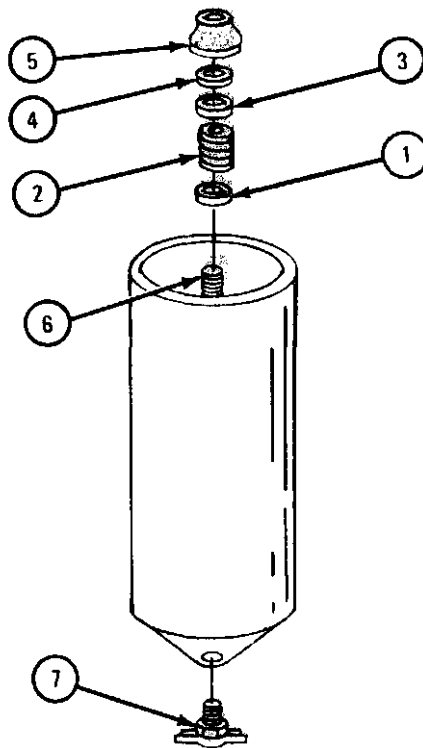

TA 047010

FRAME 2

1. Put new filter element (1) into filter housing (2).
2. Put filter head gasket (3) into filter head (4).
3. Fit filter housing (2) to filter head (4). Screw in sleeve nut (5) with gasket (6).
4. Using torque wrench with 1-inch socket wrench, tighten sleeve nut (5) to 180 pound-inches.
5. Using 7/8-inch wrench, screw in and tighten two fittings (7 and 8) to positions noted.

END OF TASK

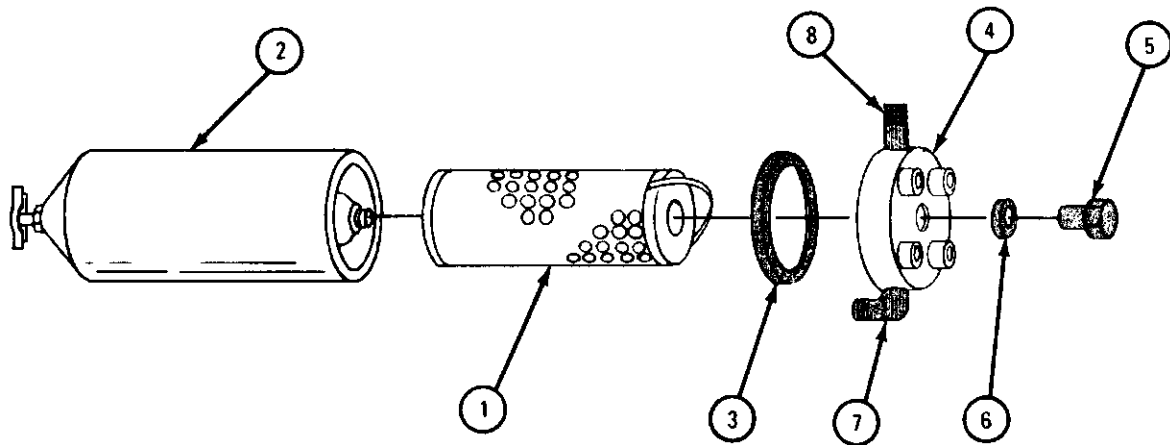

TA 047011

f. Assembly of Secondary and Final Fuel Filters.

NOTE

This task is the same for secondary fuel filter and final fuel filter. This task is shown for final fuel filter.

FRAME 1

1. Using 9/16-inch wrench, screw in and tighten drain cock (1).
2. Put spring (2), washer (3), gasket (4), and cup (5) on post (6) as shown.
3. Press down on cup (5) and using long nose pliers, put cotter pin (7) through hole in post (6) and bend open ends of cotter pin.
4. Put filter element (8) into filter housing (9) .

GO TO FRAME 2

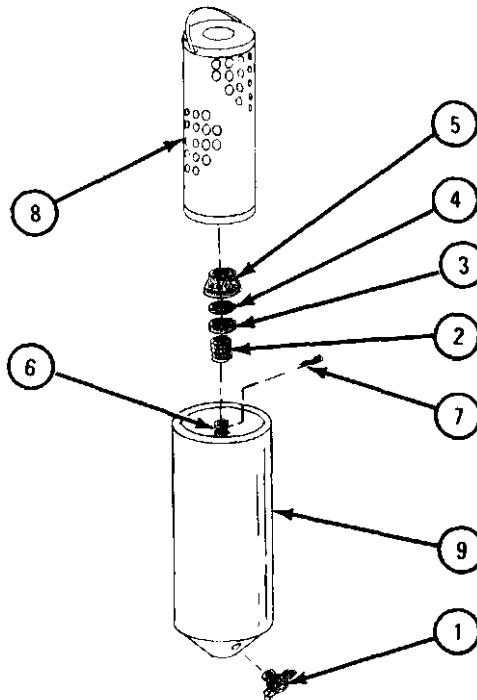

TA 047517

FRAME 2

1. Put filter head gasket (1) into filter head (2).
2. Fit filter housing (3) to filter head (2). Screw in sleeve nut (4) with washer (5) and gasket (6).
3. Using torque wrench with 5/8-inch socket wrench, tighten sleeve nut (4) to 180 pound-inches.

NOTE

Some trucks have only one bleeder valve (7).

4. Using 7/16-inch wrench, screw in and tighten two bleeder valves (7) .
5. Using 9/16-inch wrench, screw on and tighten three elbows (8) to positions noted.
6. Using 5/8-inch wrench, screw on and tighten elbow (9).

NOTE

Follow-on Maintenance Action Required:

Put fuel filters back in truck. Refer to para 4-10.

END OF TASK

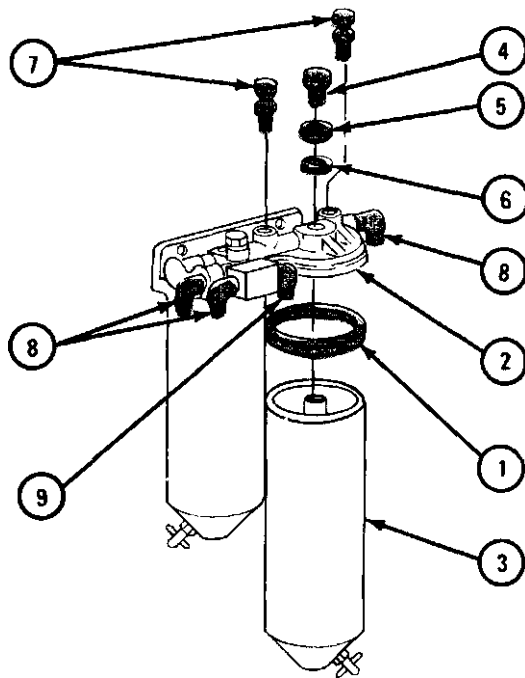

TA 047518

Section V. ENGINE STARTING AIDS

4-12. MANIFOLD HEATER (TOP-MOUNTED, UNCOVERED) NOZZLE AND VALVE ASSEMBLY REMOVAL AND REPLACEMENT (TRUCKS WITH ENGINES LDS 427-2 AND LDS 465-1).

TOOLS : 13/16-inch wrench 5/16-inch wrench
 5/8-inch wrench 7/16-inch wrench
 1-gallon container 1-inch wrench

SUPPLIES : None

PERSONNEL: One

EQUIPMENT CONDITION : Truck parked, engine off, handbrake set.

Preliminary Procedure. Open hood and right side panel. Refer to TM 9-2320-209-10.

b. Removal.

FRAME 1

1. Put container under nozzle and valve assembly (1) .
2. Using 5/16-inch wrench, unscrew and take off tube nut (2).
3. Using 13/16-inch and 5/8-inch wrenches, hold nozzle and valve assembly (1) and unscrew and take off bushing (3) .
4. Using 7/16-inch wrench, unscrew and take off tube nut (4) .
5. Using 1-inch and 13/16-inch wrenches, loosen locking nut (5) and unscrew and take off nozzle and valve assembly (1).

END OF TASK

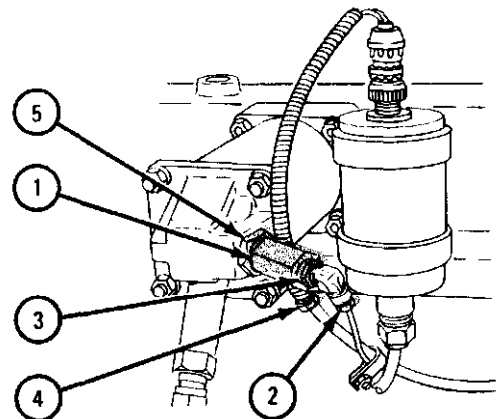
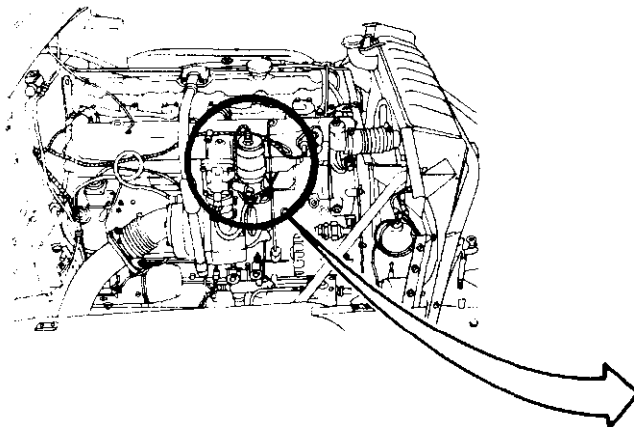

TA 086456

c. Replacement.

FRAME 1

1. Screw in and hand tighten nozzle and valve assembly (1).
2. Using 13/16-inch and 1-inch wrenches, hold nozzle and valve assembly (1) and tighten locking nut (2),
3. Using 13/16-inch and 5/8-inch wrenches, hold nozzle and valve assembly (1) and screw in and tighten bushing (3) .
4. Using 7/16-inch wrench, screw in and tighten tube nut (4) .
5. Using 5/16-inch wrench, screw in and tighten tube nut (5) .
6. Take away container and put liquid in approved disposal area.

NOTE

Follow-on Maintenance Action Required:

Close hood and right side panel. Refer to TM 9-2320-209-10.

END OF TASK

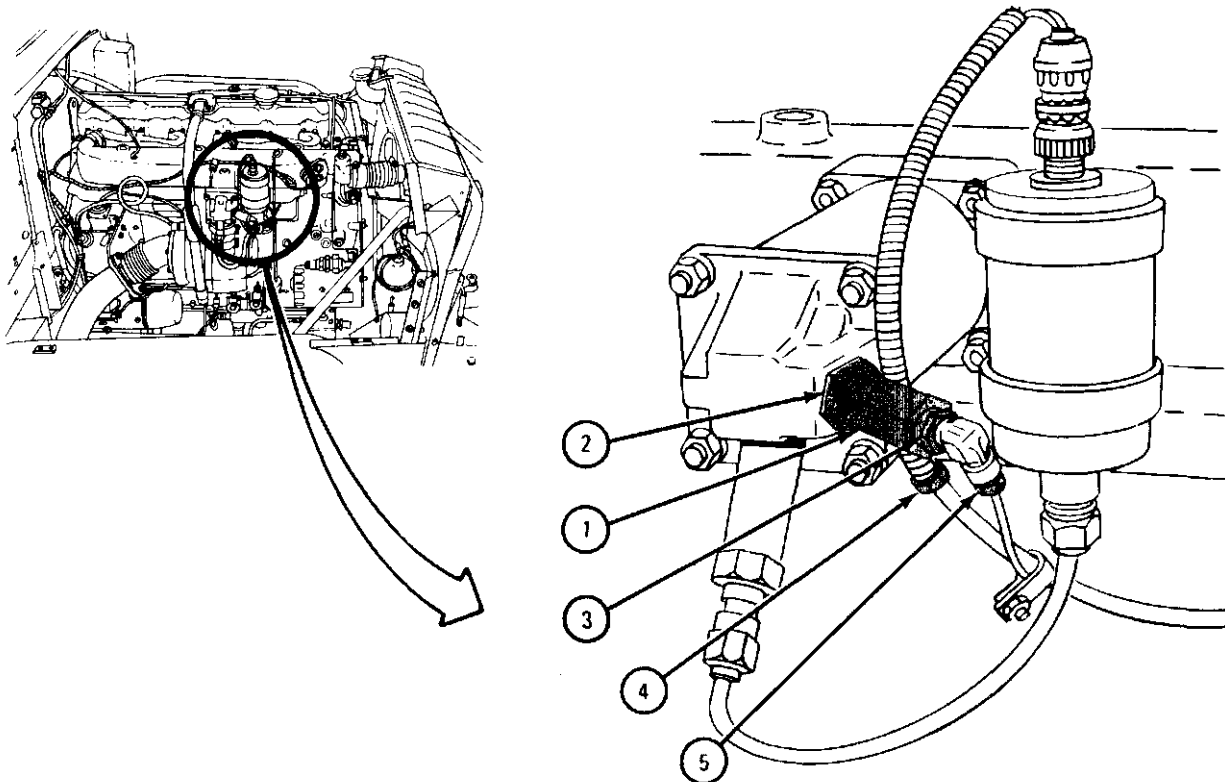

TA 086457

4-13. MANIFOLD HEATER (TOP-MOUNTED, UNCOVERED) IGNITION UNIT
REMOVAL AND REPLACEMENT.

TOOLS: 1/2-inch wrench
7/8-inch wrench
Pliers

SUPPLIES : None

PERSONNEL: One

EQUIPMENT CONDITION: Truck parked, engine off and cold, handbrake set.

a. Preliminary Procedures.

- (1) Open hood. Refer to TM 9-2320-209-10.
- (2) Disconnect battery ground cable. Refer to para 7-58.

b. Removal.

FRAME 1

1. Using 7/8-inch wrench, unscrew and take off electrical cable connector (1) from ignition unit (2).
2. Using pliers, unscrew and take off electrical cable connector (3) from ignition unit (2).
3. Using 1/2-inch wrench, unscrew and take out two screws with washers (4).
4. Slide off two clamps (5) from ignition unit (2).
5. Take out ignition unit (2).

END OF TASK

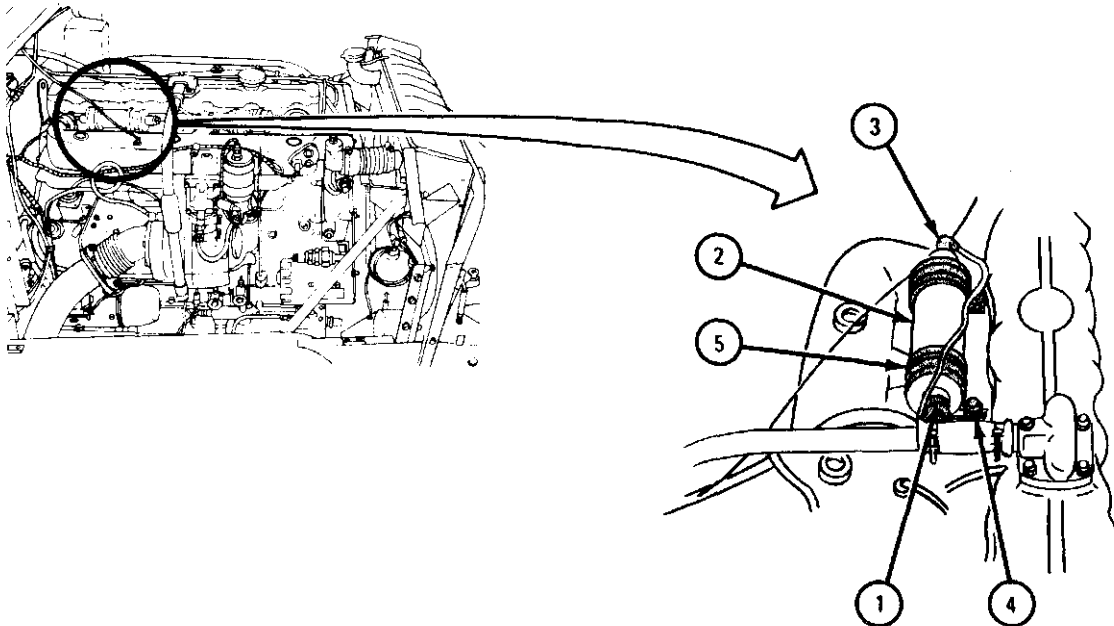

TA 083342

c. Replacement.

FRAME 1

1. Slide two clamps (1) on ignition unit (2).
2. Put ignition unit (2) with two clamps (1) in place and align screw holes.
3. Using 1/2-inch wrench, screw on and tighten two screws with washers (3).
4. Using pliers, screw on and tighten electrical cable connector (4) to ignition unit (2).
5. Using 7/8-inch wrench, screw on and tighten electrical cable connector (5) to ignition unit (2).

NOTE

Follow-on Maintenance Action Required:

1. Close hood. Refer to TM 9-2320-209-10.
2. Reconnect battery ground cable. Refer to para 7-58.

END OF TASK

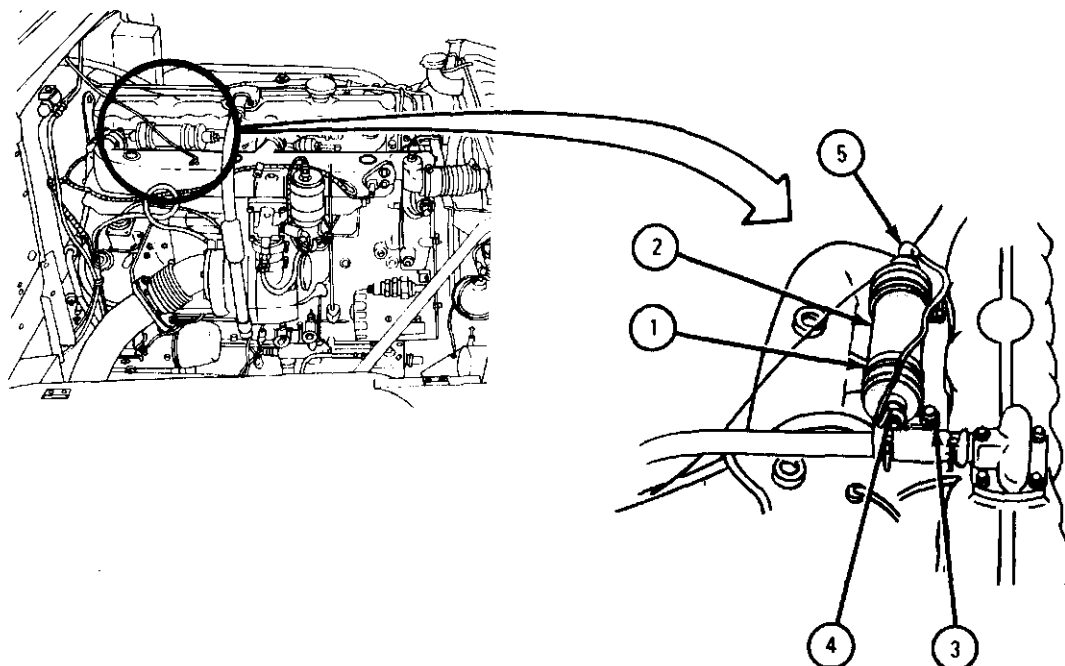

TA 083343

4-14. MANIFOLD HEATER (TOP-MOUNTED, UNCOVERED) SPARK PLUG REMOVAL AND REPLACEMENT (TRUCKS WITH ENGINES LDS 427-2 AND LDS 465-1).

TOOLS : 3/4-inch wrench
7/8-inch wrench

SUPPLIES: None

PERSONNEL: One

EQUIPMENT CONDITION: Truck parked, engine off, handbrake set.

a. Preliminary Procedure. Open hood and right side panel. Refer to TM 9-2320-209-10

b. Removal.

FRAME 1

1. Using 3/4-inch wrench, unscrew and take off coupling nut (1).
2. Using 7/8-inch wrench, unscrew and take off sparkplug (2). Take off gasket (3).

END OF TASK

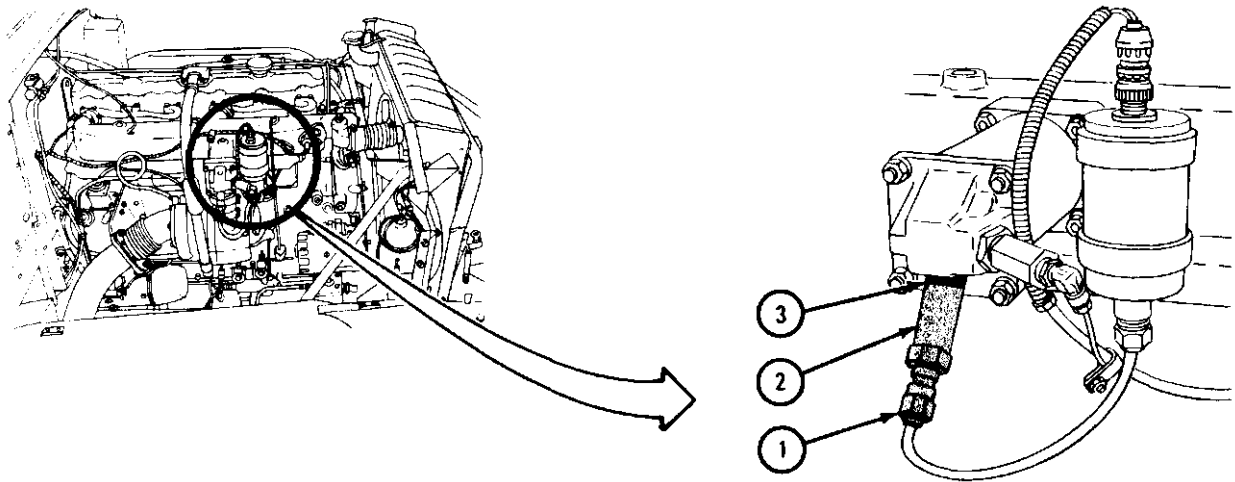

TA 086458

Replacement.

FRAME 1

1. Put gasket (1) on sparkplug (2). Using 7/8-inch wrench, screw on and tighten spark plug (2).
2. Using 3/4-inch wrench, screw on and tighten coupling nut (3).

NOTE

Follow-on Maintenance Action Required:

Close hood and right side panel. Refer to TM 9-2320-209-10.

END OF TASK

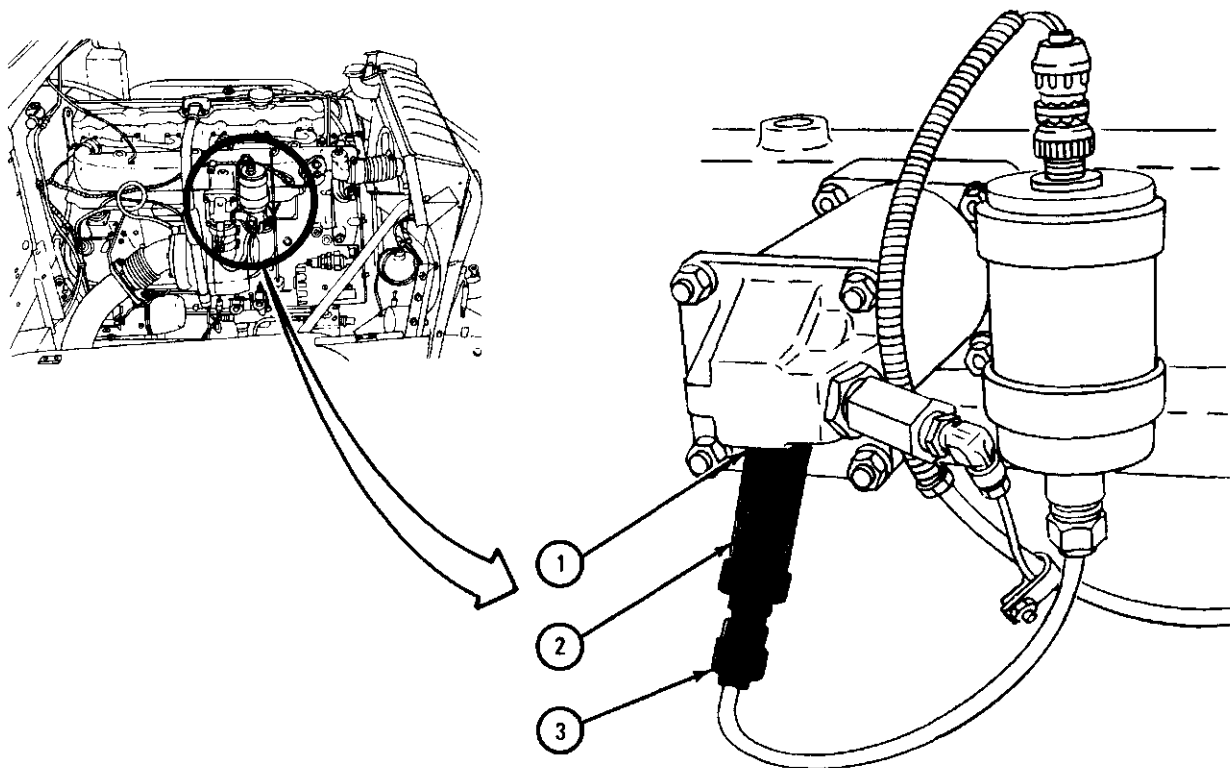

TA 086455

4-15. MANIFOLD HEATER (SIDE-MOUNTED) FUEL FILTER REMOVAL AND REPLACEMENT.

TOOLS : Flat-tip screwdriver, stubby
9/16-inch combination box and open end box wrench
7/16-inch wrench
3/8-inch wrench
1-gallon container

SUPPLIES: None

PERSONNEL: One

EQUIPMENT CONDITION : Truck parked, engine off, handbrake set.

Preliminary Procedure. Open hood and right side panel. Refer to
TM 9-2320-209-10.

b. Removal.

WARNING

Do not permit smoking, sparks or open flame within 50 feet of work area. Fuel could explode, causing injury to personnel and damage to equipment.

FRAME 1

1. Put container under nut (1).
2. Working under truck using 9/16-inch wrench, hold nut (1). Using 7/16-inch combination box and open end box wrench, unscrew and take off tube nut (2) . Let fuel drain into container.

GO TO FRAME 2

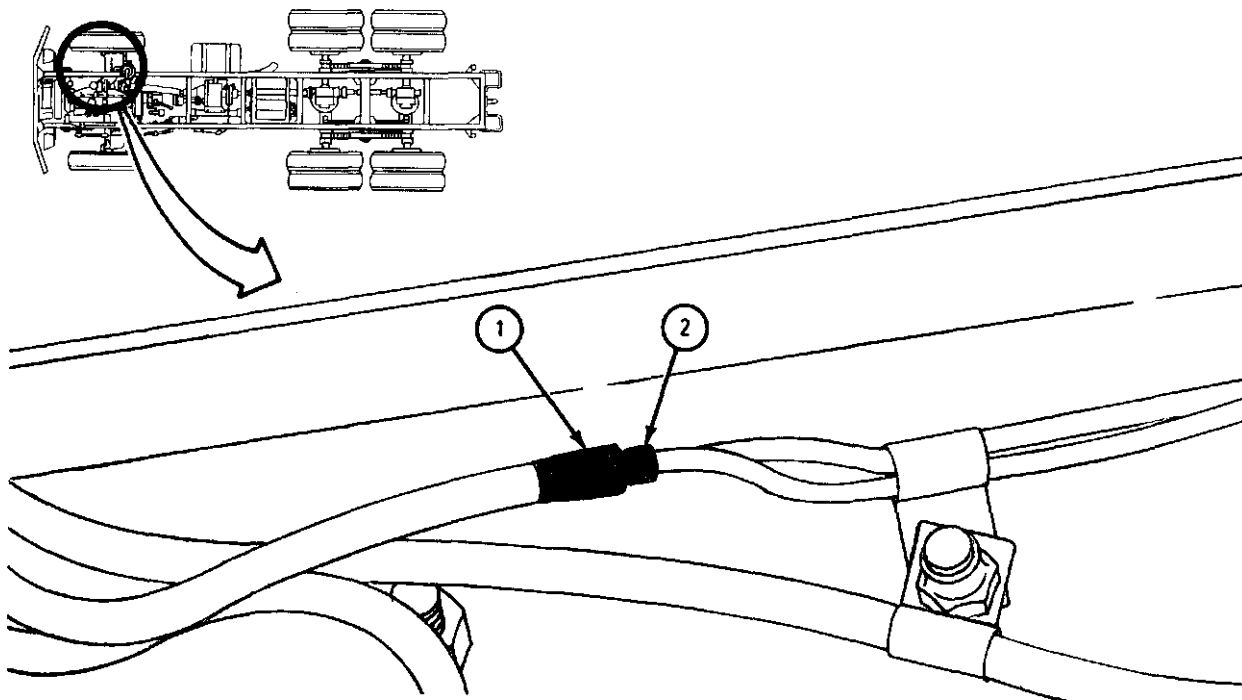

TA 085546

FRAME 2

1. Working under truck and using 9/16-inch wrench, unscrew and take off fuel line (1) .

GO TO FRAME 3

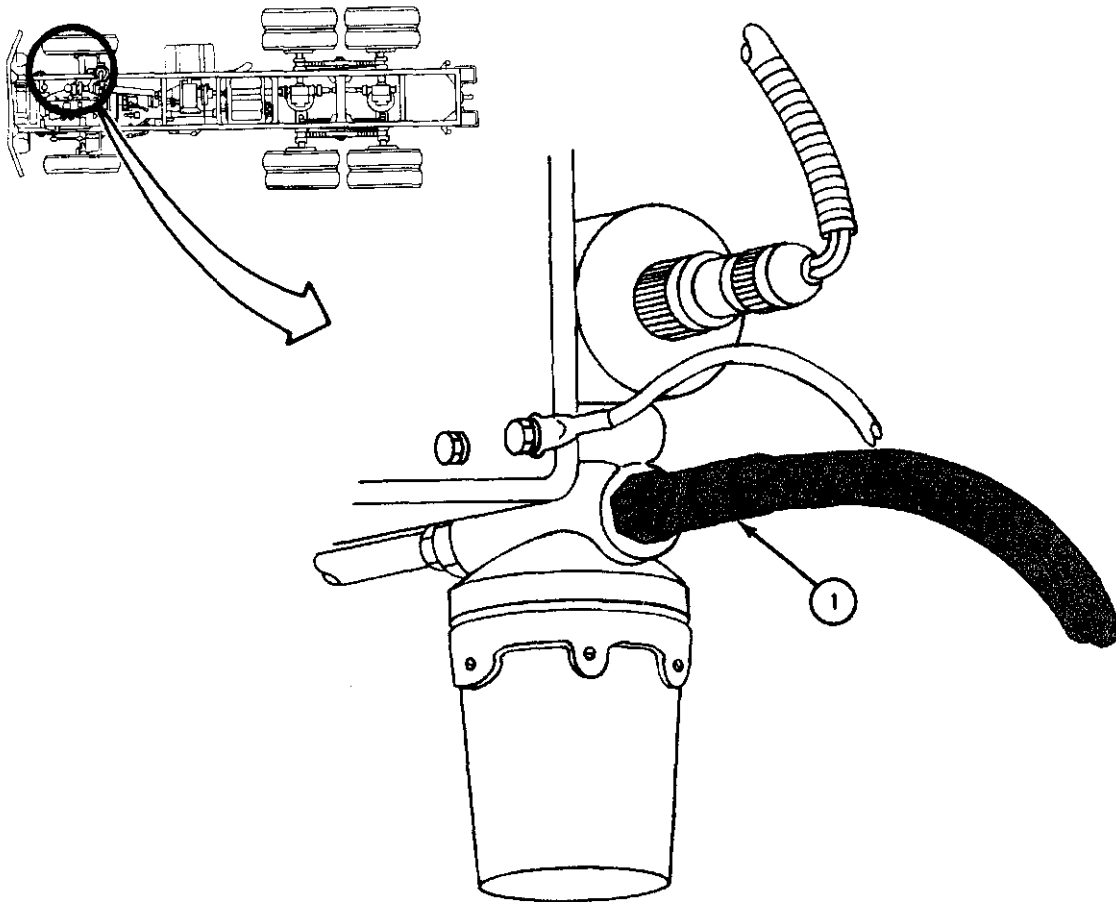

TA 085558

FRAME 3

1. Put container under adapter fitting (1).
2. Working undertrick and using 9/16-inch wrench, hold adapter fitting (1). Using 7/16-inch combination box and open end box wrench, unscrew and take off tube nut (2).
3. Let fuel drain into container.

GO TO FRAME 4

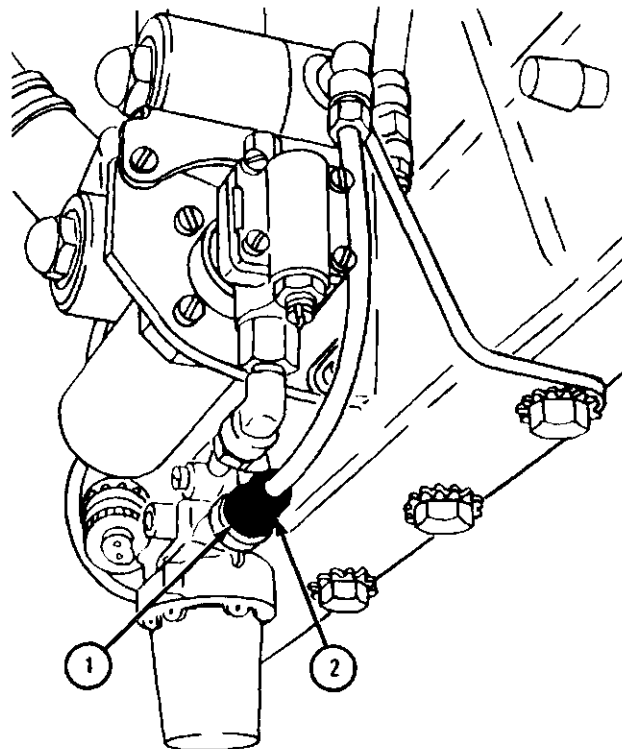
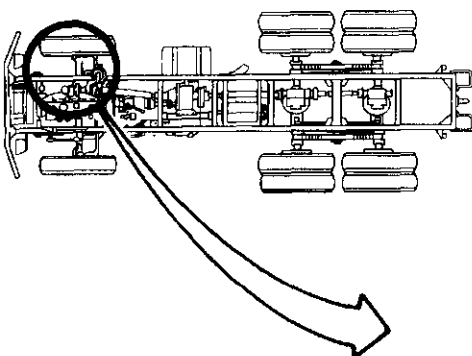

TA 085559

FRAME 4

1. Using screwdriver and 3/8-inch wrench, unscrew and take off two nuts (1) , two washers (2) , ground wire (3) , and two screws (4).
2. Take off fuel filter (5) .
3. Put fuel in container in approved disposal area.

END OF TASK

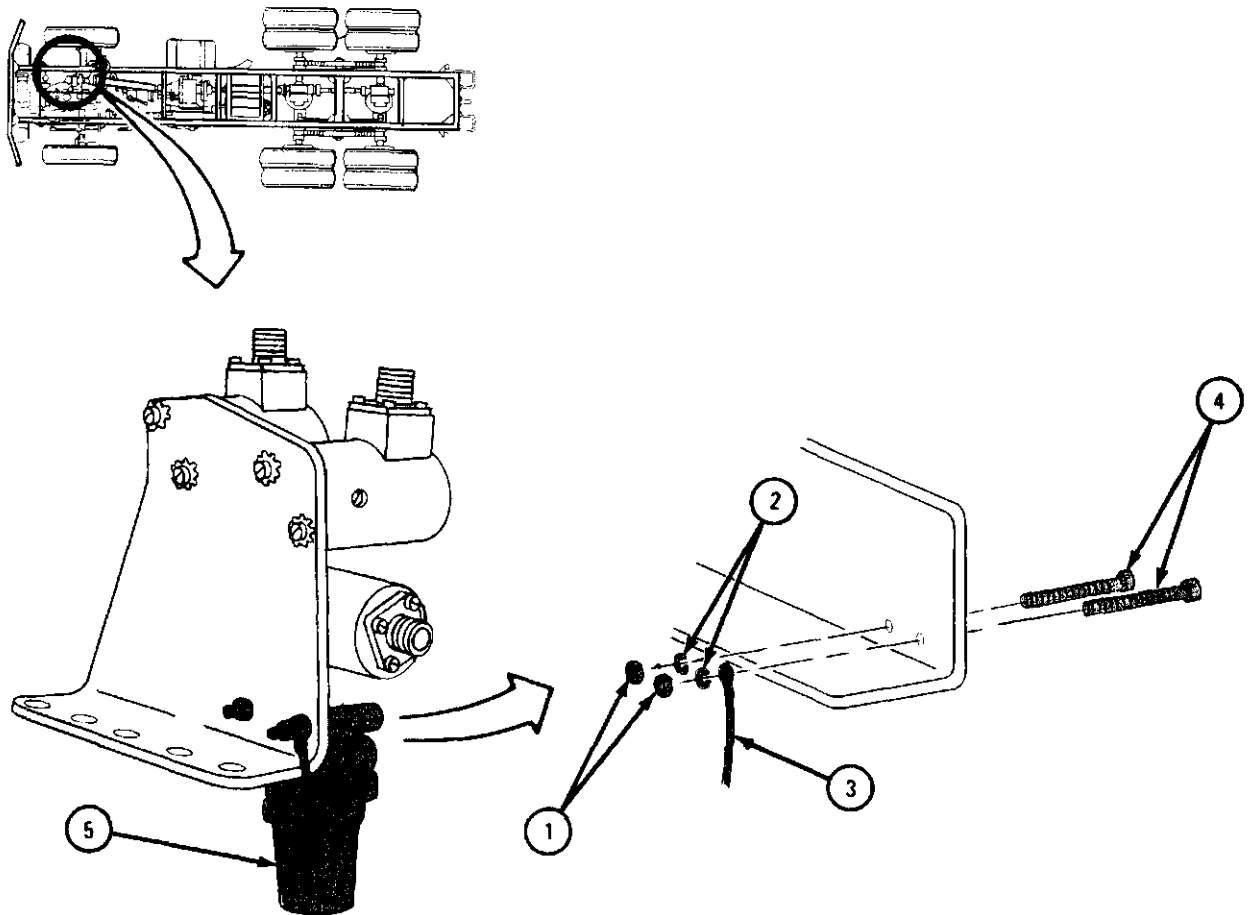

TA 101640

Replacement.

FRAME 1

1. Place fuel filter (1) on bracket (2), alining screw holes. Put in two screws (3).
 2. Put on ground wire (4) and two washers (5).
 3. Using screwdriver and 3/8-inch wrench, screw on and tighten two nuts (6).
- GO TO FRAME 2

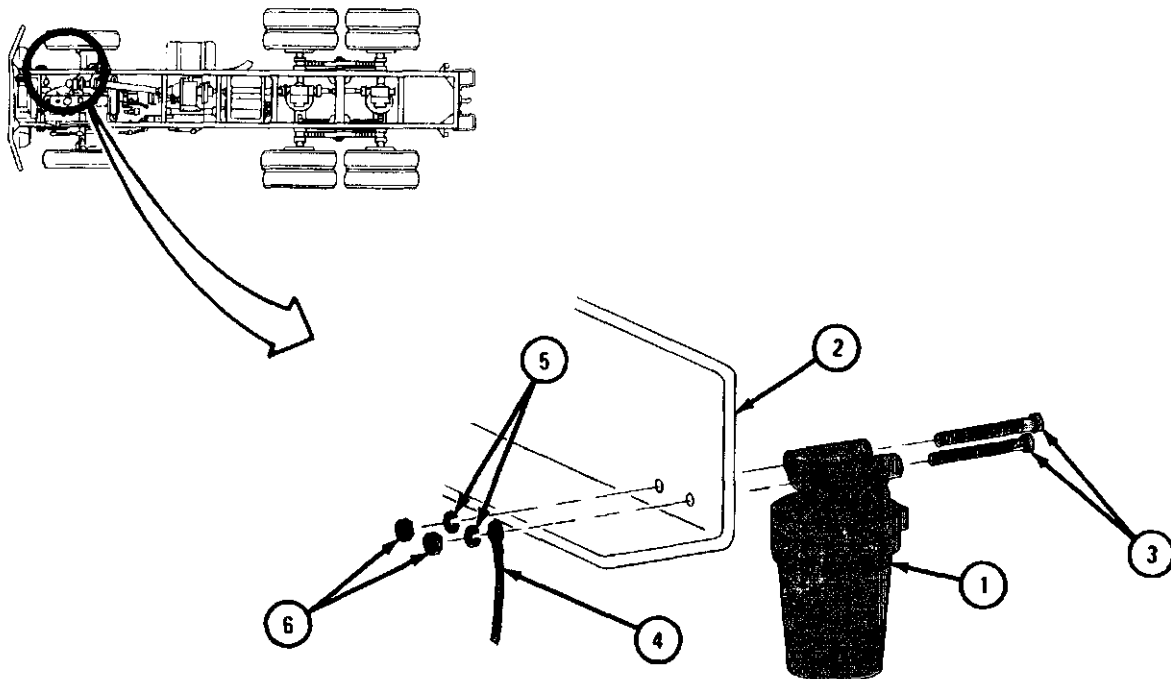

TA 101641

FRAME 2

1. Working under truck using 9/16-inch wrench, hold adapter fitting (1). Using 7/16-inch combination box and open end box wrench, screw in and tighten tube nut (2).

GO TO FRAME 3

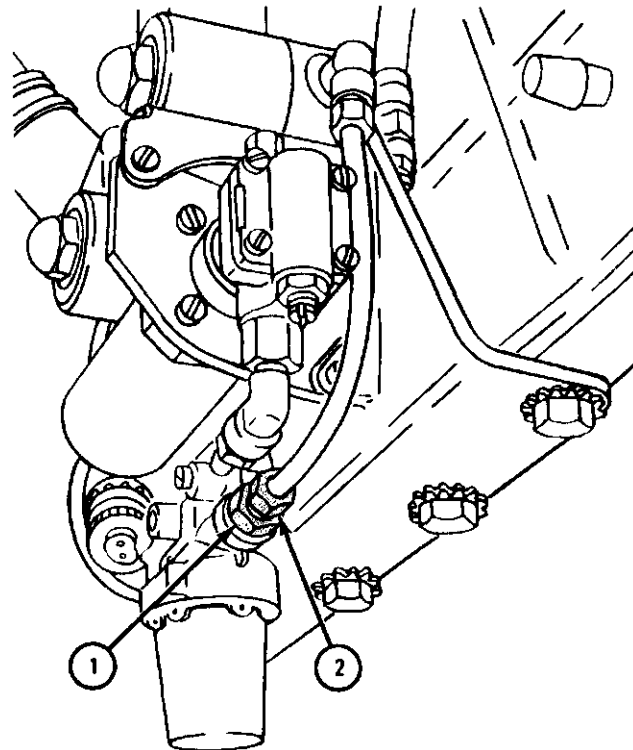
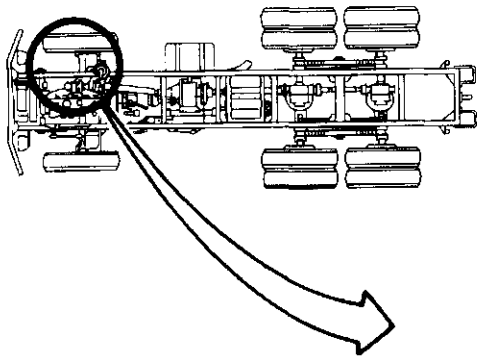

TA 085559

FRAME 3

1. Working under truck using 9/16-inch wrench, screw on and tighten tube nut on fuel line (1).

GO TO FRAME 4

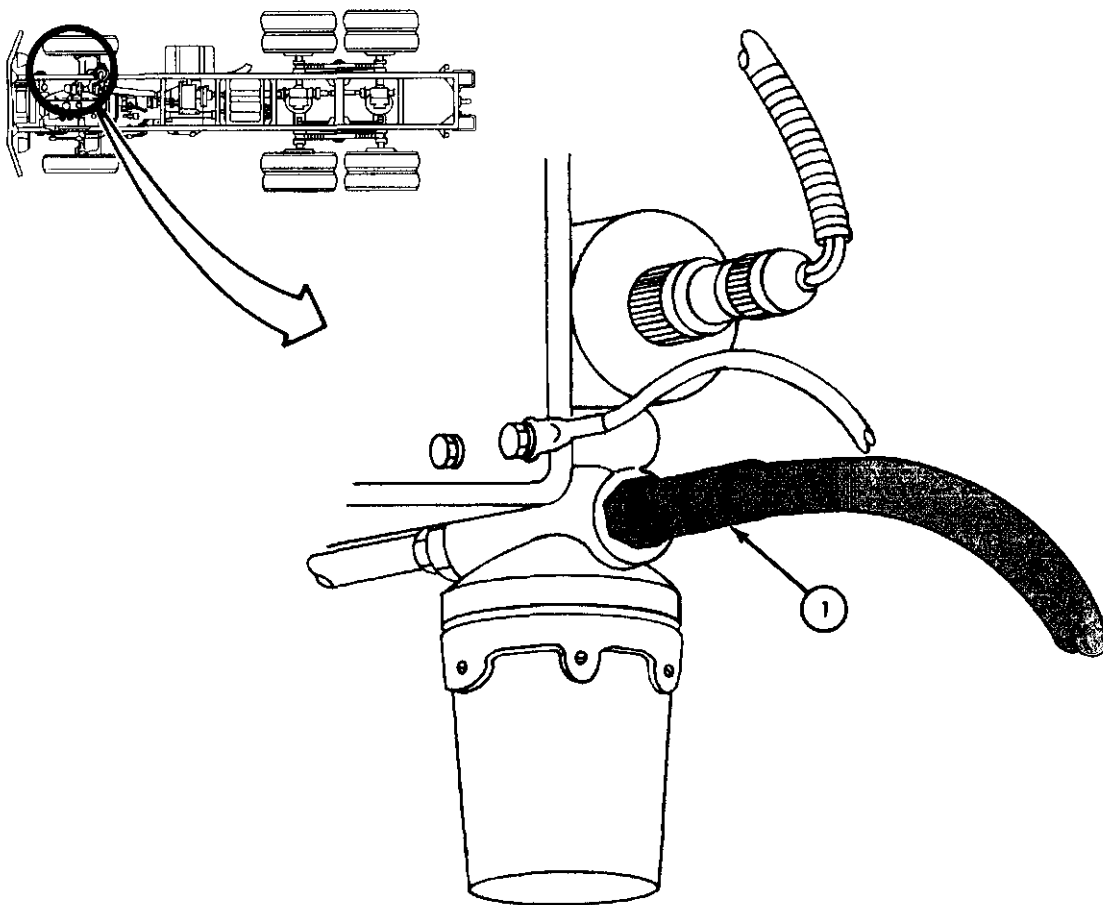

TA 085558

FRAME 4

1. Working under truck using 9/16-inch wrench, hold nut (1). Using 7/16-inch combination box and open end box wrench, screw on and tighten tube nut (2) .

NOTE

Follow-on Maintenance Action Required:

Close hood and right side panel. Refer to TM 9-2320-209-10.

END OF TASK

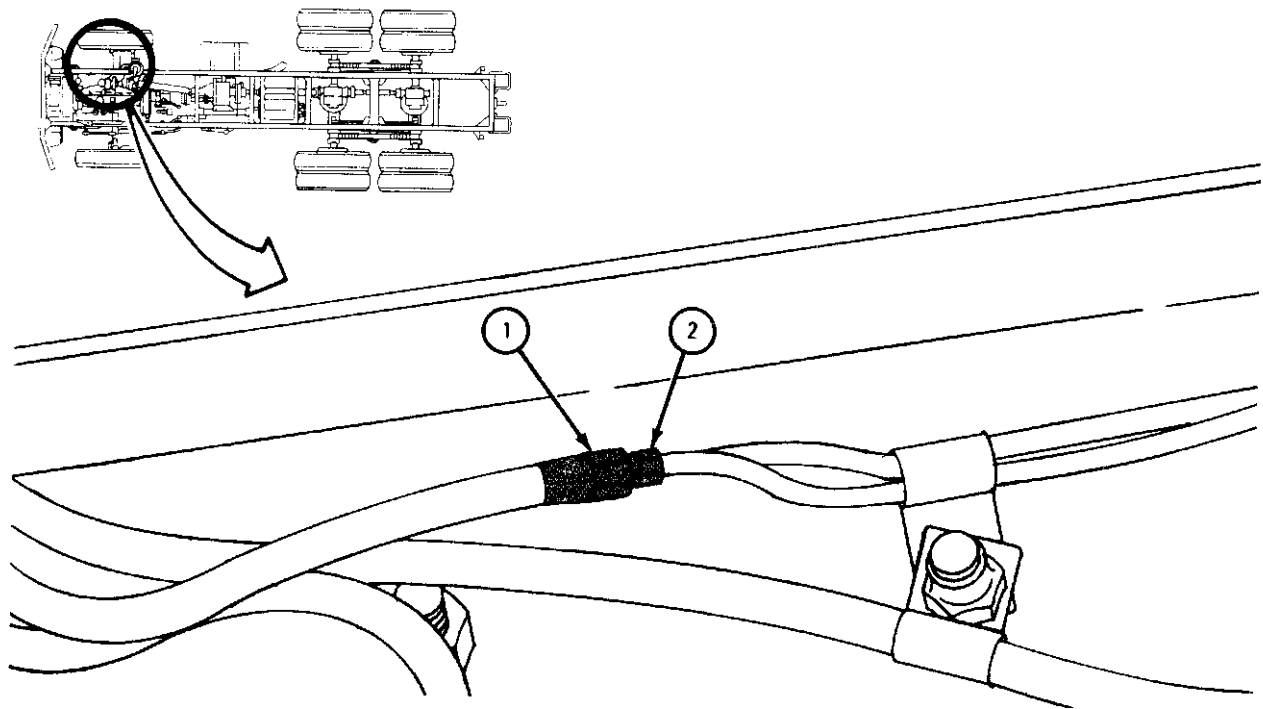

TA 085546

4-16. MANIFOLD HEATER (SIDE-MOUNTED) SPARK PLUG AND NOZZLE REMOVAL AND REPLACEMENT.

TOOLS : 5/16-inch wrench (2) 7/8-inch wrench
 7/16-inch wrench (2) 13/16-inch wrench
 3/4-inch wrench

SUPPLIES: None

PERSONNEL: One

EQUIPMENT CONDITION: Truck parked, engine off, handbrake set.

a. Preliminary Procedures.

(1) Open hood and right side panel. Refer to TM 9-2320-209-10.

(2) Disconnect battery ground cable. Refer to para 7-58.

b. Removal.

FRAME 1

1. Using 3/4-inch wrench, unscrew and take off electrical cable connector (1) from sparkplug (2).
2. Using 7/8-inch wrench, unscrew and takeoff sparkplug (2) with gasket (3).
3. Using 7/16-inch wrenches, unscrew and take off fuel return tube fitting (4).
4. Using 5/16-inch wrenches, unscrew and take off fuel inlet tube fitting (5).
5. Using 7/16-inch wrench, unscrew and takeoff elbow (6).
6. Using 13/16-inch wrench, unscrew and takeoff nozzle (7).

END OF TASK

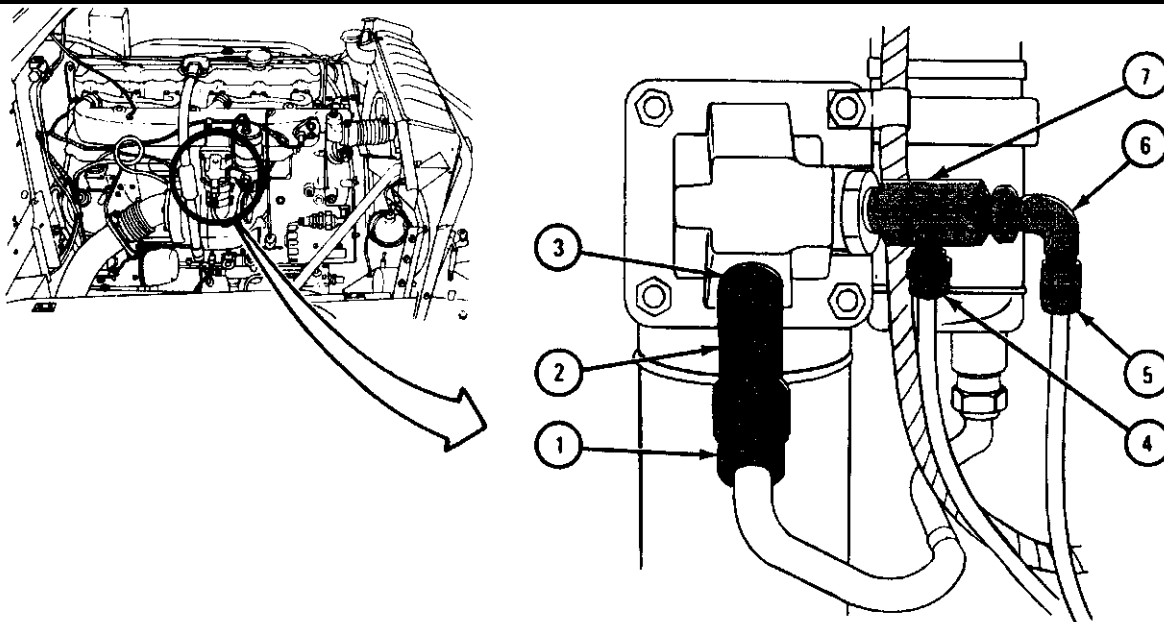

TA 083327

Replacement.**FRAME 1**

1. Using 13/16-inch wrench, screw in and tighten nozzle (1).
2. Using 7/16-inch wrench, screw on and tighten elbow (2) to nozzle (1).
3. Using 5/16-inch wrench, screw on and tighten inlet tube fitting (3).
4. Using 7/16-inch wrenches, screw on and tighten return tube fitting (4).
5. Put gasket (5) on spark plug (6) and using 7/8-inch wrench, screw on and tighten spark plug (6).
6. Using 3/4-inch wrench, screw on and tighten electrical cable connector (7).

NOTE**Follow-on Maintenance Action Required:**

1. Reconnect battery ground cable. Refer to para 7-58.
2. Close hood and right side panel. Refer to TM 9-2320-209-10.

END OF TASK

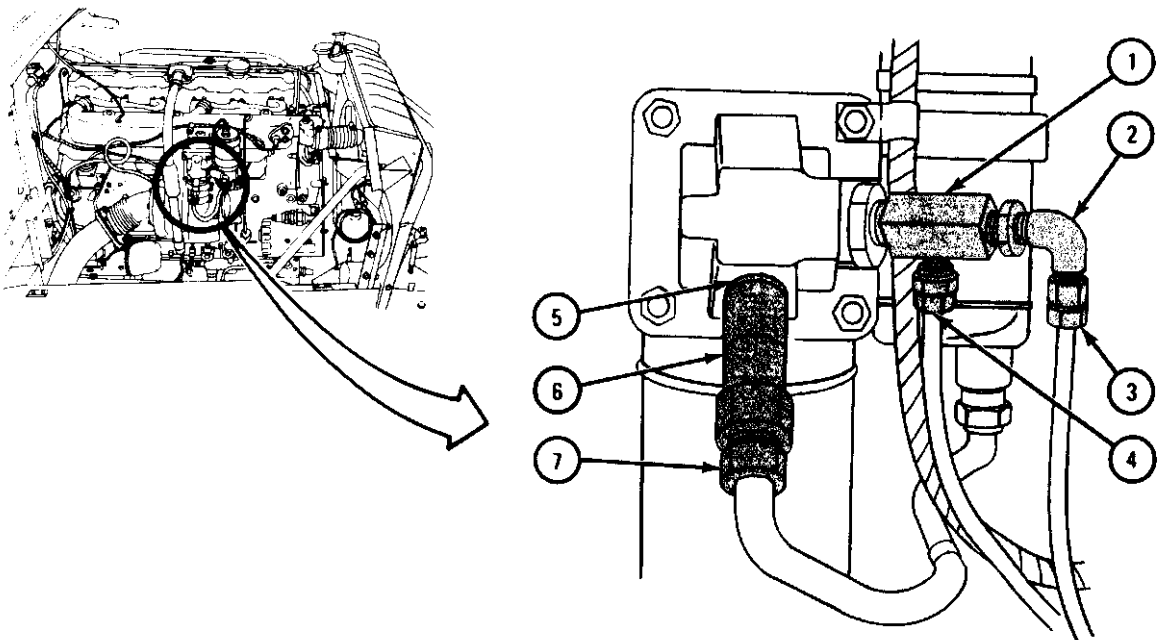

TA 083328

4-17. ENGINE MANIFOLD HEATER REMOVAL AND REPLACEMENT
(TRUCKS WITH ENGINES LDS 427-2 AND LDS 465-1).

TOOLS : 5/16-inch wrench 7/16-inch wrench
 1/2-inch wrench 7/8-inch wrench
 9/16-inch wrench 5/8-inch wrench
 3/4-inch wrench 1-inch wrench

SUPPLIES : Spark plug gasket
 Heater gasket
 Solvent, dry cleaning, type II (SD-2), Fed. Spec P-D-680

PERSONNEL : One

EQUIPMENT CONDITION : Truck parked, engine off, handbrake set.

Preliminary Procedure. Open hood and right side panel. Refer to
TM 9-2320-209-10.

b. Removal.

FRAME 1

1. Using 3/4-inch wrench, unscrew and take off ignition lead and fitting (1).
2. Using 7/8-inch wrench, unscrew and take out spark plug (2). Throw away gasket (3).
3. Using 5/16-inch wrench, unscrew coupling nut (4) and take fuel line (5) out of elbow (6).

NOTE

Note position of elbow so it will be put back in same way.

4. Using 5/8-inch wrench, unscrew and take out elbow (6).
5. Using 9/16-inch 7/16-inch wrenches, unscrew coupling nut (7) and take fuel line (8) out of adapter (9).
6. Using 1-inch wrench, unscrew and take out nozzle and valve assembly (10).

GO TO FRAME 2

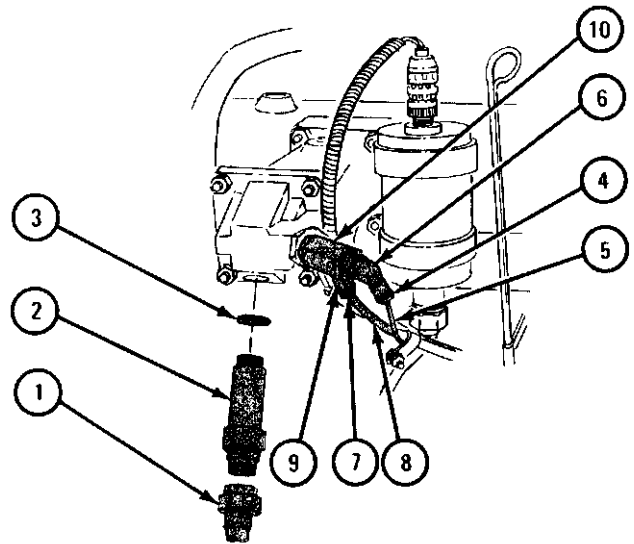
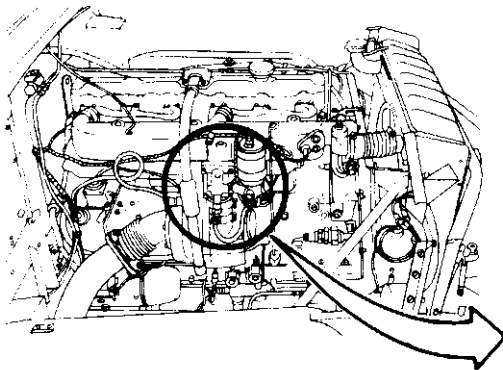

TA 047062

FRAME 2

1. Using 1/2-inch wrench, unscrew and take off four nuts (1) and lockwashers (2) from four threaded studs (3).
2. Pull clamp (4) off bottom right stud (3) and leave clamp on ignition harness (5).
3. Take housing assembly (6) off mounting elbow (7).
4. Take off and throw away gasket (8).

END OF TASK

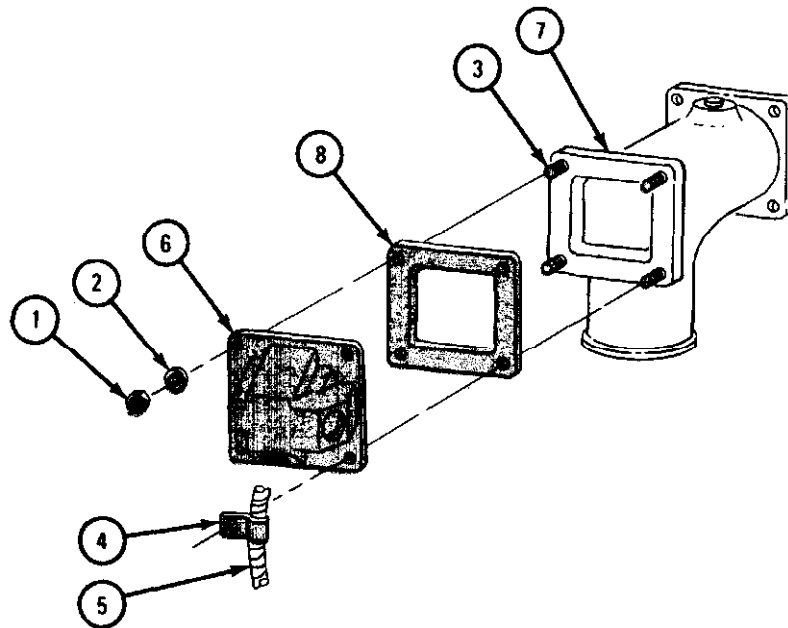

TA 047063

c. Replacement.

FRAME 1

WARNING

Dry cleaning solvent is flammable. Do not use near an open flame. Keep a fire extinguisher nearby when solvent is used. Use only in well-ventilated places. Failure to do this may result in injury to personnel and damage to equipment.

1. Clean surfaces of housing assembly (1) and mounting elbow (2) with solvent.
2. Put gasket (3) on four threaded studs (4).
3. Press housing assembly (1) over threaded studs (4) until it is seated against gasket (3).
4. Put clamp (5) holding ignition harness (6) on bottom right threaded stud (4).
5. Using 1/2-inch wrench, screw on and tighten four nuts (7) with four lockwashers (8).

GO TO FRAME 2

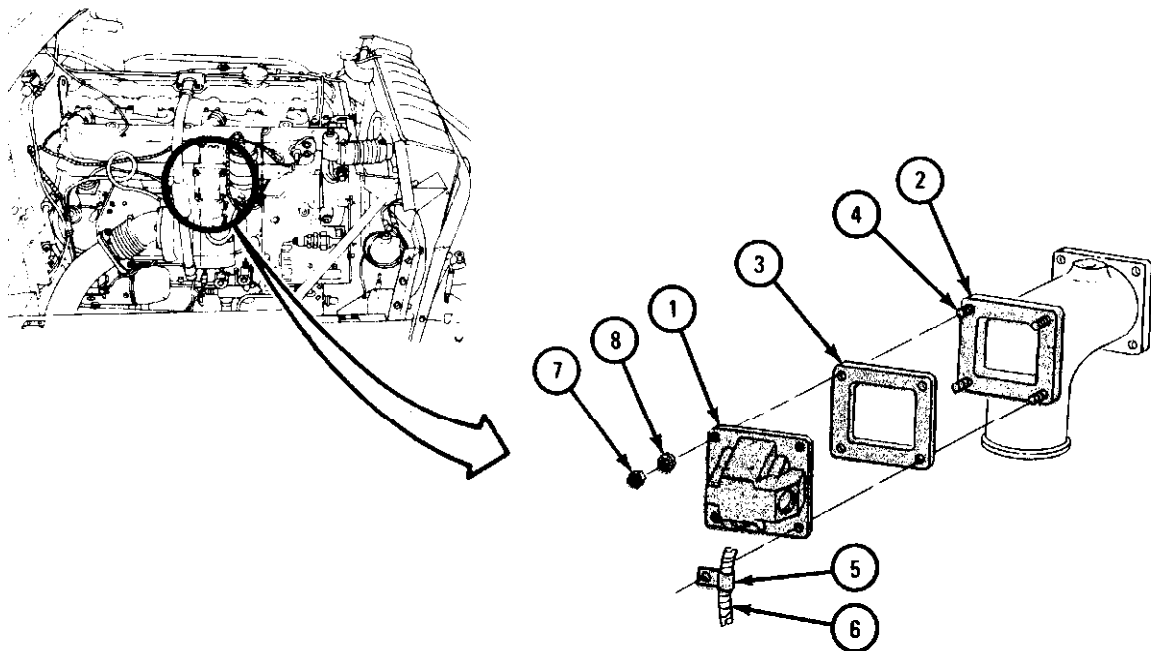

TA 047064

FRAME 2

1. Screw spark plug (1) with gasket (2) into housing assembly (3). Using 7/8-inch wrench, tighten spark plug.
2. Using 3/4-inch wrench, screw on and tighten ignition lead with fitting (4).
3. Using 1-inch wrench, screw in and tighten nozzle and valve assembly (5).
4. Using 5/8-inch wrench, screw in and tighten elbow (6) to position noted.
5. Put small fuel line (7) into elbow (6) and using 5/16-inch wrench, screw in and tighten coupling nut (8).
6. Put large fuel line (9) into nozzle and valve assembly (5). Using 9/16-inch and 7/16-inch wrenches, screw in and tighten coupling nut (10).

GO TO FRAME 3

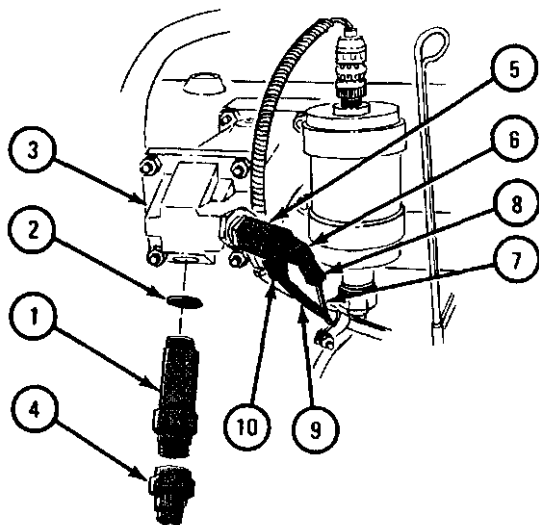

TA 047065

FRAME 3

NOTE

Follow-on Maintenance Action Required:

1. Check operation of engine manifold heater. Refer to TM 9-2320-209-10.
2. Check manifold heater fuel lines and fittings for leaks.
3. Turn off engine manifold heater. Refer to TM 9-2320-209-10.
4. Close hood and right side panel. Refer to TM 9-2320-209-10.

END OF TASK

4-18. MANIFOLD HEATER FUEL PUMP REMOVAL AND REPLACEMENT
(TRUCKS WITH ENGINES LDS 427-2 AND LDS 465-1).

- TOOLS : 5/16-inch wrench
7/16-inch wrench
3/8-inch wrench
Cross-tip screwdriver (Phillips type)
Slip joint pliers

SUPPLIES: Container

PERSONNEL: One

EQUIPMENT CONDITION: Truck parked, engine off, handbrake set.

Preliminary Procedure. Open hood and right side panel. Refer to
TM 9-2320-209-10.

b. Removal.

NOTE

Set manifold heater switch to OFF position.

FRAME 1

1. Put container under manifold heater fuel pump (1).
2. Using pliers, unscrew and take off electrical connector (2).
3. Using 7/16-inch wrench, unscrew coupling nut (3) and take out fuel tube (4) from elbow (5).
4. Using 5/16-inch and 7/16-inch wrenches, unscrew coupling nut (6) from union (7) and take out fuel tube (8) from union.

GO TO FRAME 2

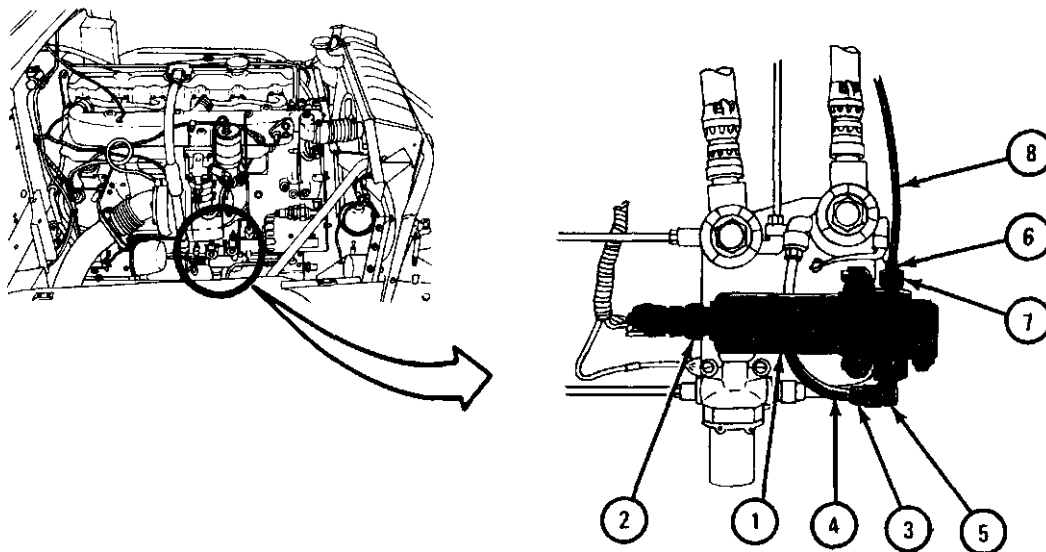

TA 047058

FRAME 2

1. Using screwdriver and 3/8-inch wrench, unscrew and take off two nuts (1) and two lockwashers (2).
2. Pull off pump (3) from mounting bracket (4) and take out two screws (5) .

END OF TASK

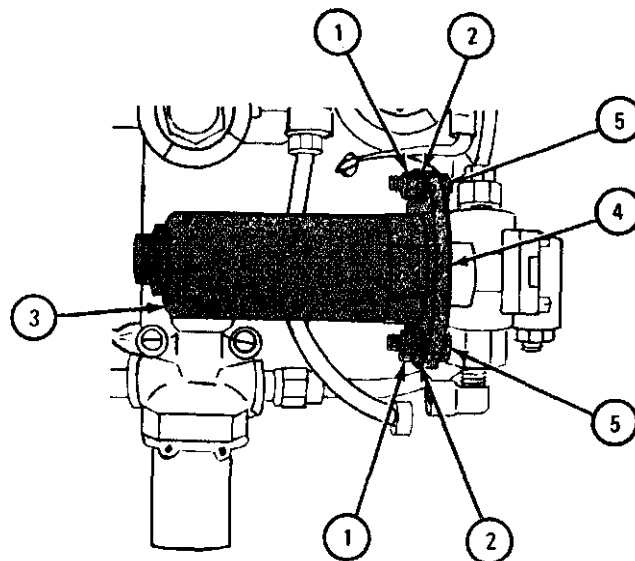

TA 047059

c. Replacement.

FRAME 1

1. Put pump (1) in place, alining holes in pump mounting flange (2) with holes in mounting bracket (3).
2. Put two screws (4) through holes in mounting bracket (3) and pump mounting flange (2).
3. Using screwdriver and 3/8-inch wrench, screw on and tighten two nuts (5) and lockwashers (6).

GO TO FRAME 2

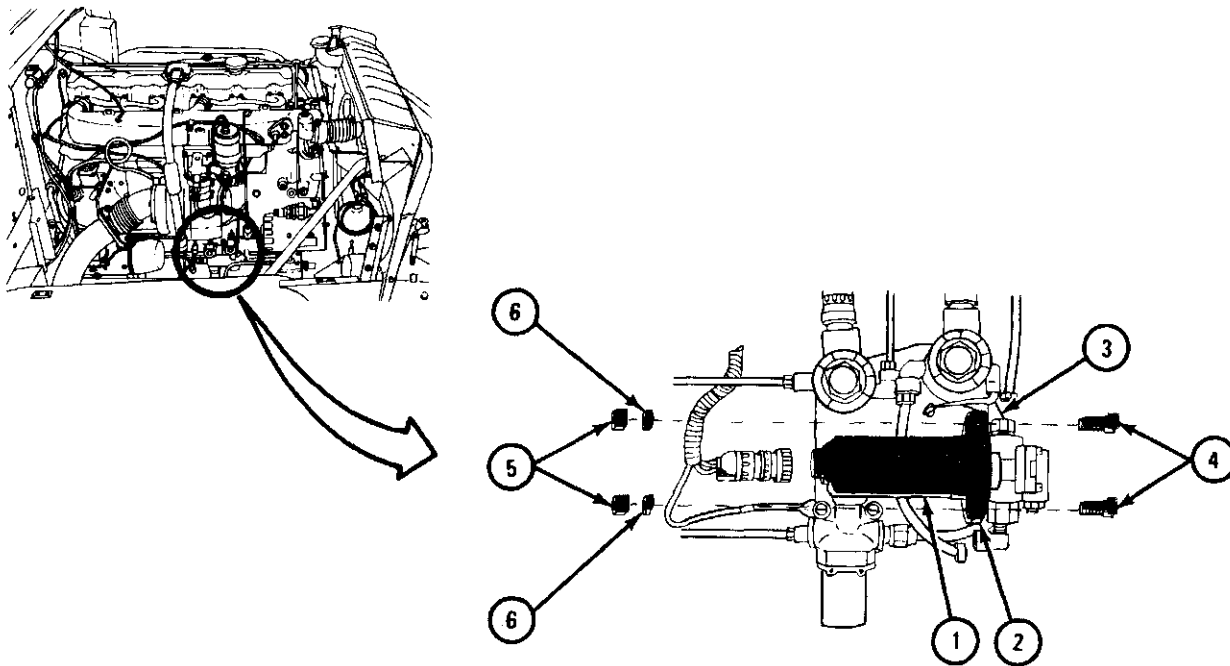

TA 047060

FRAME 2

1. Using 5/6-inch and 7/16-inch wrenches, join fuel tube (1) to union (2) and screw on and tighten coupling nut (3).
2. Using 7/16-inch wrench, join fuel tube (4) to elbow (5) and screw on and tighten coupling nut (6).
3. Plug connector (7) into pump (8). Using pliers, screw in and tighten connector.

NOTE

Follow-on Maintenance Action Required:

1. Turn on engine manifold heater. Refer to TM 9-2320-209-10.
2. Check all manifold heater pump fuel lines and fittings for leaks. Check manifold heater operation.
3. Turn off engine manifold heater. Refer to TM 9-2320-209-10.
4. Close hood and right side panel. Refer to TM 9-2320-209-10.

END OF TASK

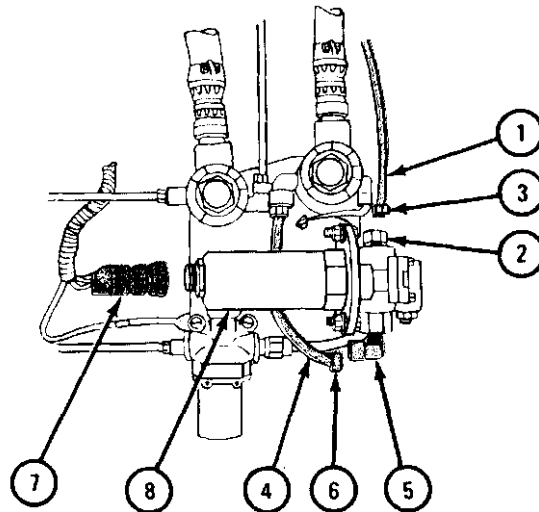

TA 087577

4-19. MANIFOLD HEATER ELECTRIC FUEL SUPPLY PUMP AND FUEL FILTER
REMOVAL AND REPLACEMENT.

TOOLS : 3/8-inch wrench
7/16-inch wrench
9/16-inch wrench (2) 1/2-inch socket wrench
11/16-inch wrench

SUPPLIES: None

PERSONNEL: One

EQUIPMENT CONDITION: Truck parked, engine off and cold, handbrake set.

a. Preliminary Procedures.

- (1) Open hood. Refer to TM 9-2320-209-10.
- (2) Disconnect battery ground cable. Refer to para 7-58.

b. Removal.

FRAME 1

1. Unscrew and takeoff electrical connector (1).
2. Using 3/8-inch wrench, unscrew and take off tube adapter (2) with tube (3).
3. Using 7/16-inch wrench, unscrew and take off tube adapter (4) with tube (5)
4. Using 1/2-inch socket wrench, unscrew and take out two screws with washers (6).
5. Takeout fuel pump (7) and filter (8).

GO TO FRAME 2

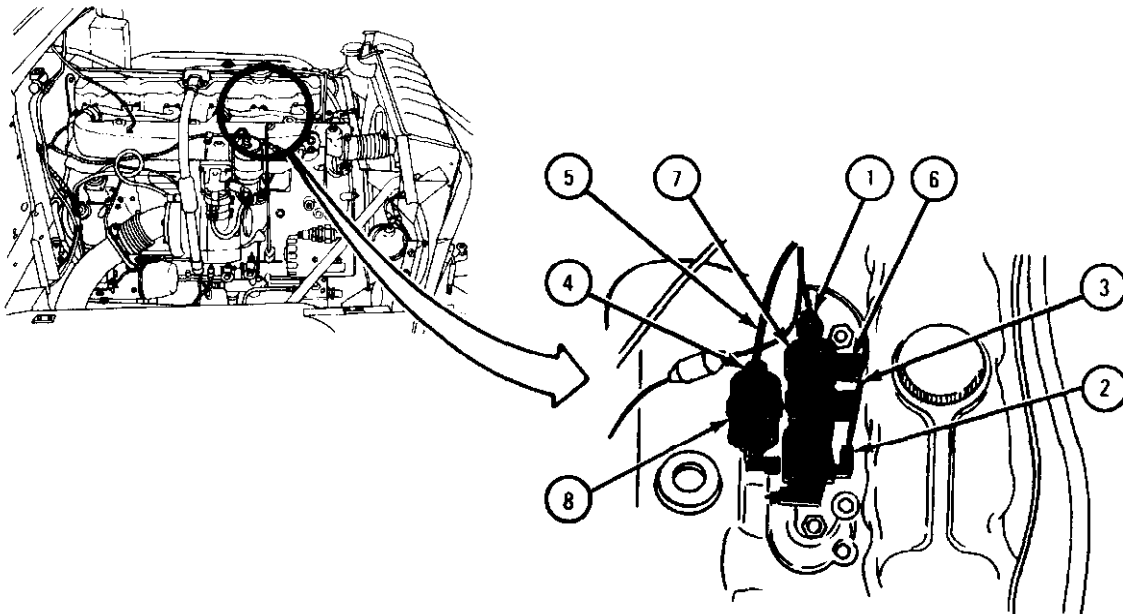

TA 083340

FRAME 2

1. Using 3/8-inch wrench, unscrew and takeout elbow (1).
2. Using 11/16-inch wrench, unscrew and take off fuel filter (2).
3. Using 9/16-inch wrench, unscrew and takeout elbow (3).
4. Using 9/16-inch wrench, unscrew and takeoff coupling nut (4).
5. Slide off two clamps (5).

END OF TASK

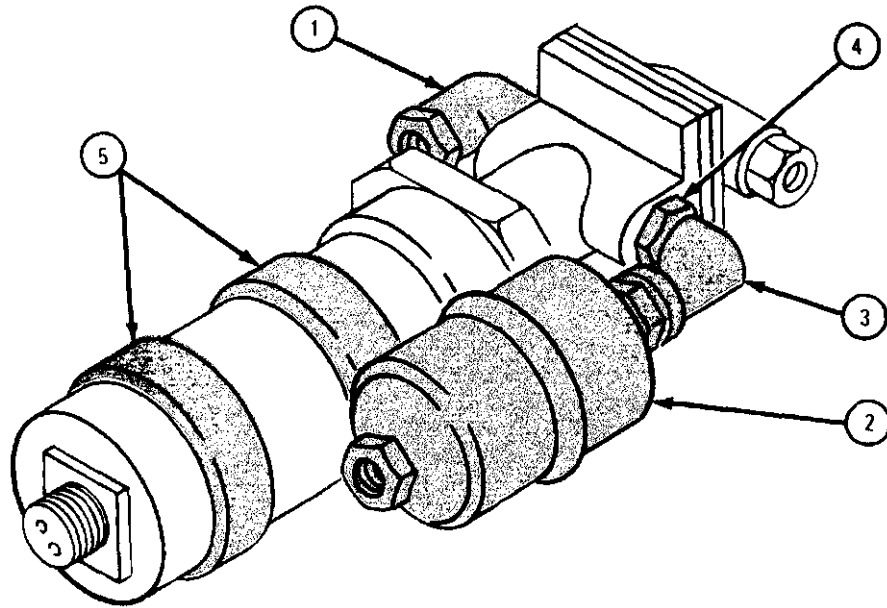

TA 101598

c. Replacement.

FRAME 1

1. Slide two clamps (1) on fuel pump (2).
2. Using 9/16-inch wrench, screw in and tighten coupling nut (3) to fuel pump (2).
3. Using 9/16-inch wrenches, screw in and tighten elbow (4) to coupling nut (3).
4. Screw filter (5) into elbow (4). Using 11/16-inch wrench, tighten filter.
5. Using 3/8-inch wrench, screw in and tighten elbow (6) to fuel pump (2).

GO TO FRAME 2

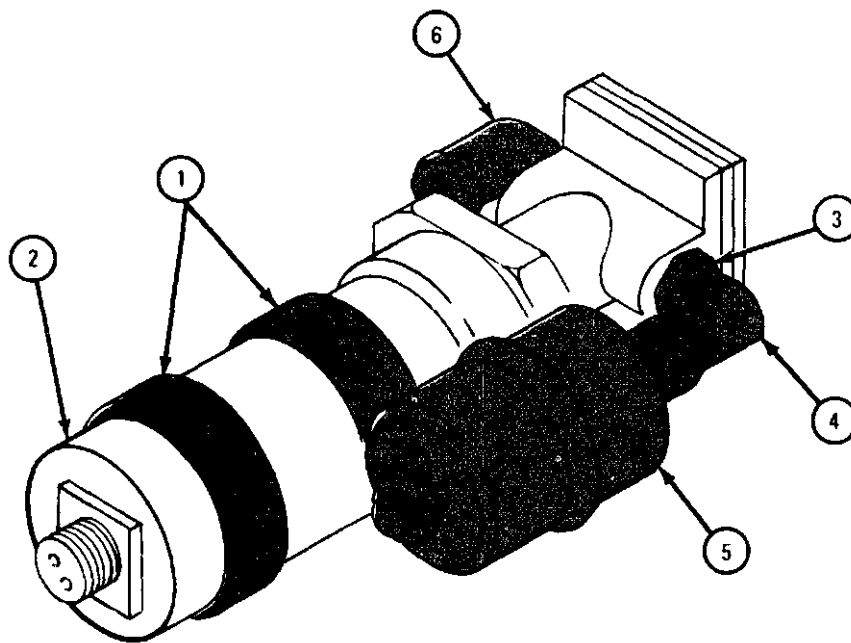

TA 083344

FRAME 2

1. Put fuel filter (1) and fuel pump (2) in place. Aline holes of two brackets (3).
2. Using 1/2-inch socket wrench, screw on and tighten two screws with washers (4).
3. Using 7/16-inch wrench, screw on and tighten tube adapter (5) to filter (1).
4. Using 3/8-inch wrench, screw on and tighten tube adapter (6) to pump (2).
5. Screw on and tighten electrical connector (7) to fuel pump (2).

NOTE

Follow-on Maintenance Action Required:

1. Reconnect battery ground cable. Refer to para 7-58.
2. Close hood. Refer to TM 9-2320-209-10.

END OF TASK

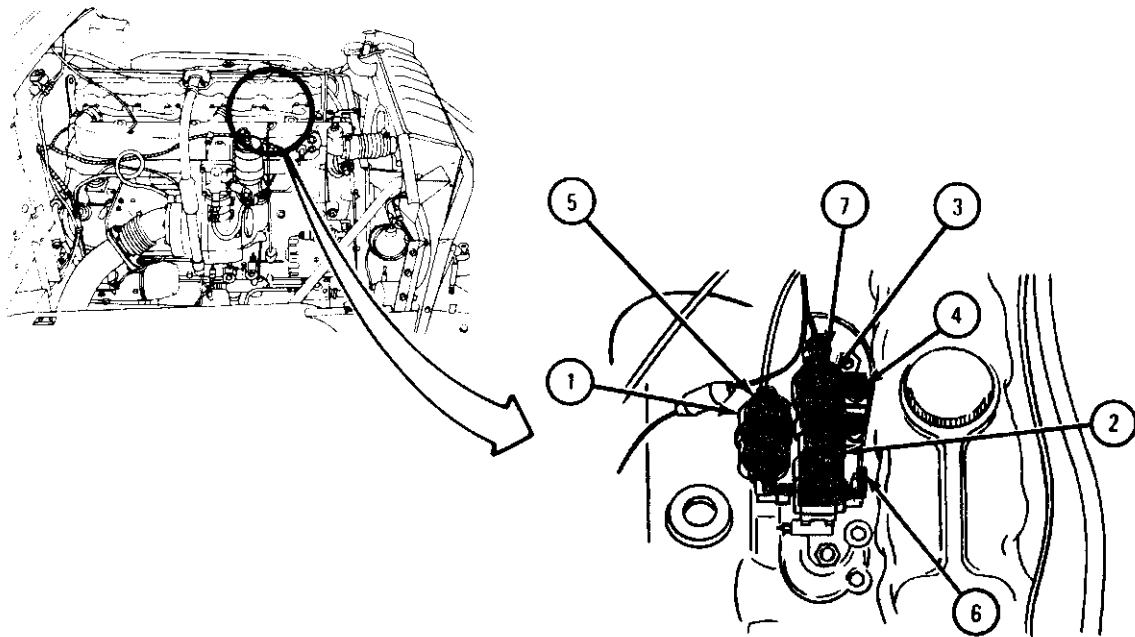

TA 083341

FRAME 2

1. Using 9/16-inch open end wrench, hold nut (1). Using 7/16-inch open end wrench, unscrew and slide back nut (2) on tube (3) .
2. Using 9/16-inch and 7/16-inch wrenches, unscrew and slide back nut (4) on tube (5).
3. Using 9/16-inch wrench, unscrew and take out nut (6) and fuel return hose (7) .
4. Using 9/16-inch wrench, unscrew and take out nut (8) and fuel supply hose (9) .

GO TO FRAME 3

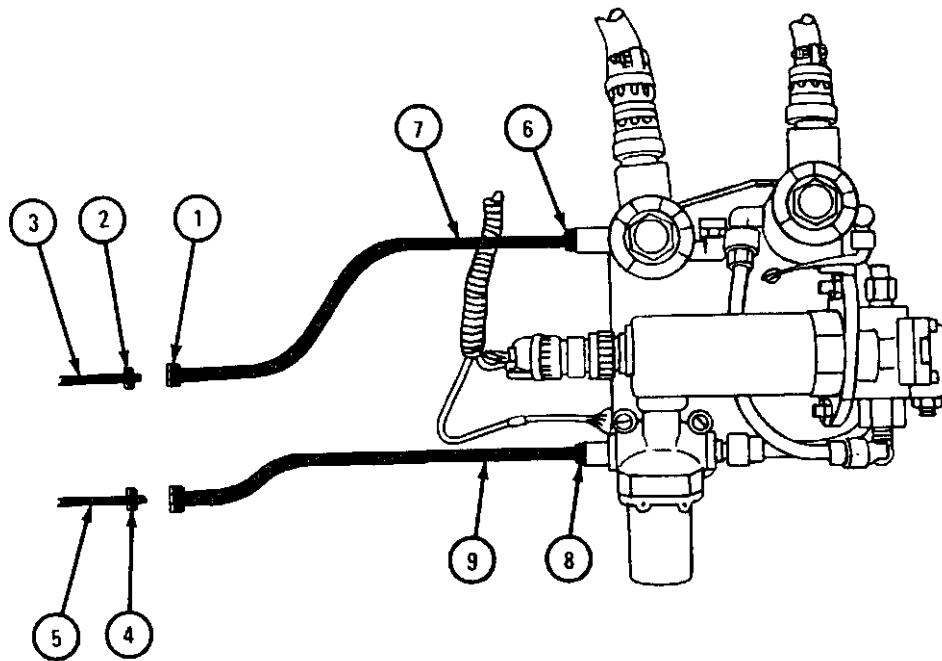

A 087560

FRAME 3

1. Unscrew connector (1) from fuel supply solenoid valve (2) and pull connector clear of valve.
 2. Unscrew connector (3) from fuel return solenoid valve (4) and pull connector clear of valve.
 3. Unscrew connector (5) from fuel pump (6) and pull connector clear of pump.
- GO TO FRAME 4

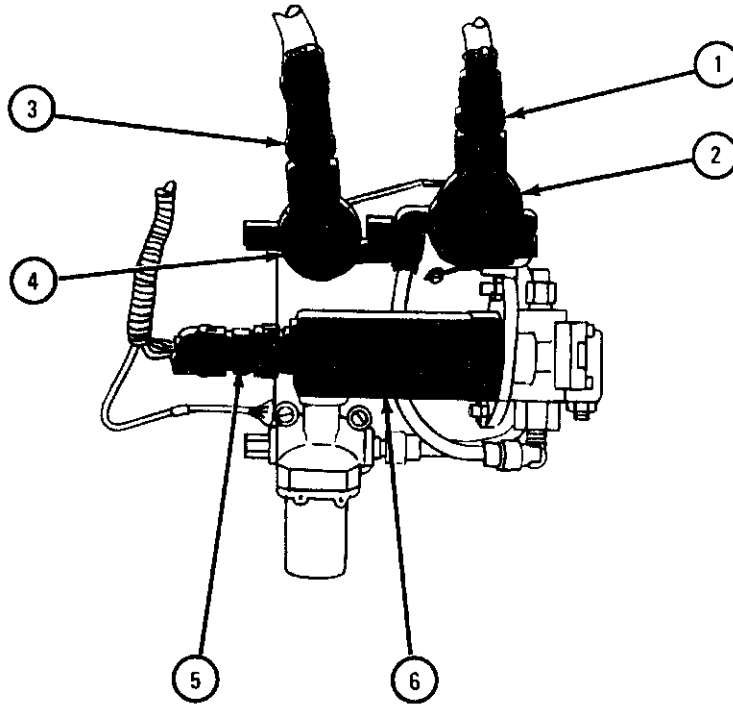

TA 087561

FRAME 4

1. Using 3/8-inch open end wrench and screwdriver, take nut (1) off screw (2).
2. Take lockwasher (3) and ground lug (4) off screw (2).
3. Take screw (2) out of mounting bracket (5).

GO TO FRAME 5

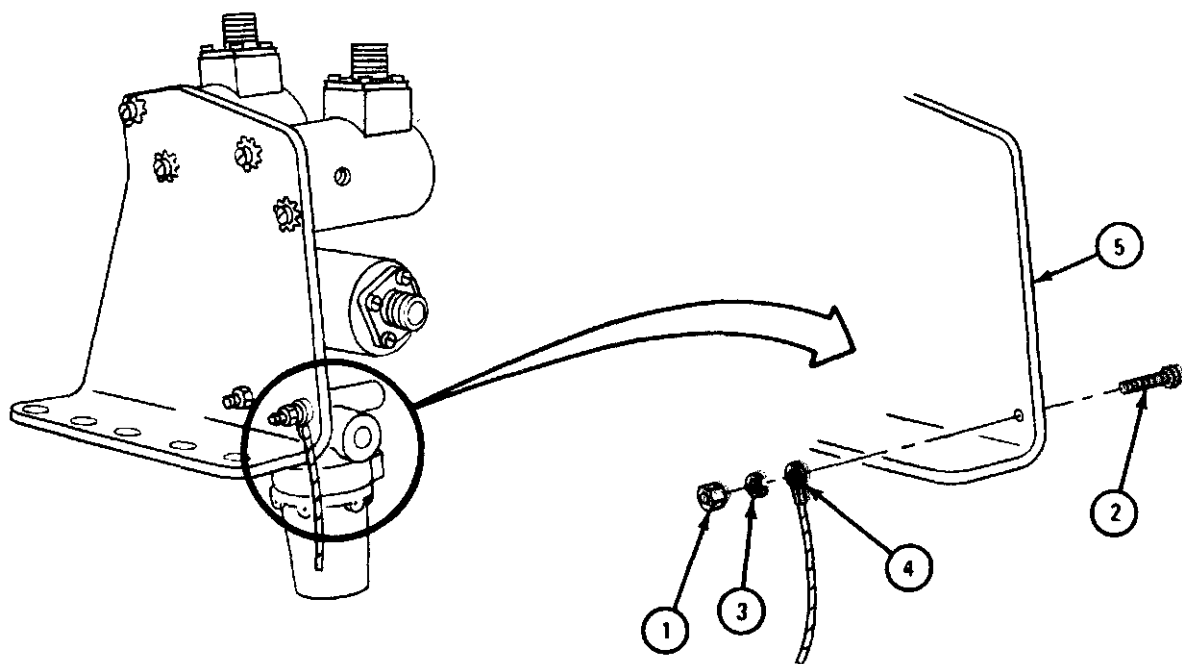

TA 047402

FRAME 5

1. Using 9/16-inch socket wrench, unscrew and take off three bolts (1) and three lockwashers (2) which hold bracket (3) to crankcase (4). Hold up bracket (3) so that it does not drop when taking out last bolt.
 2. Carefully take out bracket (3) .
- GO TO FRAME 6

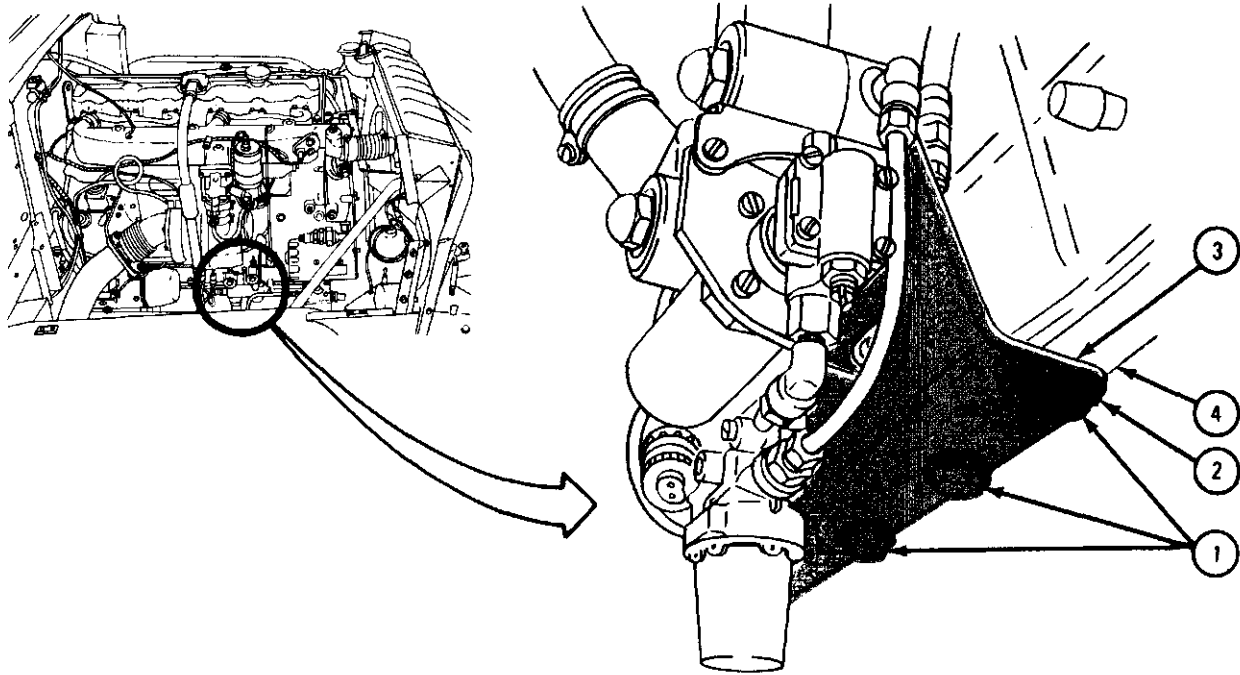

TA 047043

FRAME 6

1. Using 7/16-inch open end wrench, unscrew coupling nut (1) from adapter (2).
2. Using 7/16-inch open end wrench, unscrew coupling nut (3) from elbow (4).
3. Pull fuel supply tube (5) out of elbow (4) and adapter (2) and set fuel supply tube aside.

GO TO FRAME 7

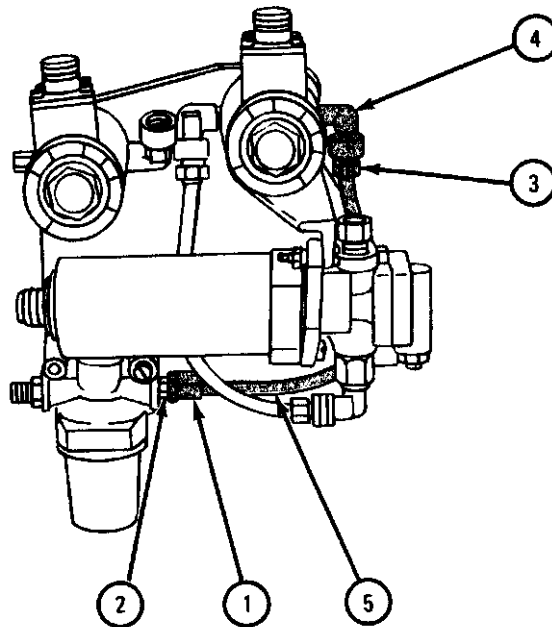

TA 087562

FRAME 7

1. Using 7/16-inch open end wrench, unscrew coupling nut (1) from elbow (2) on fuel inlet solenoid valve (3).
2. Using 7/16-inch open end wrench, unscrew coupling nut (4) from elbow (5) on fuel pump (6).
3. Pull fuel inlet tube (7) out of elbows (2) and (5) and set aside.

GO TO FRAME 8

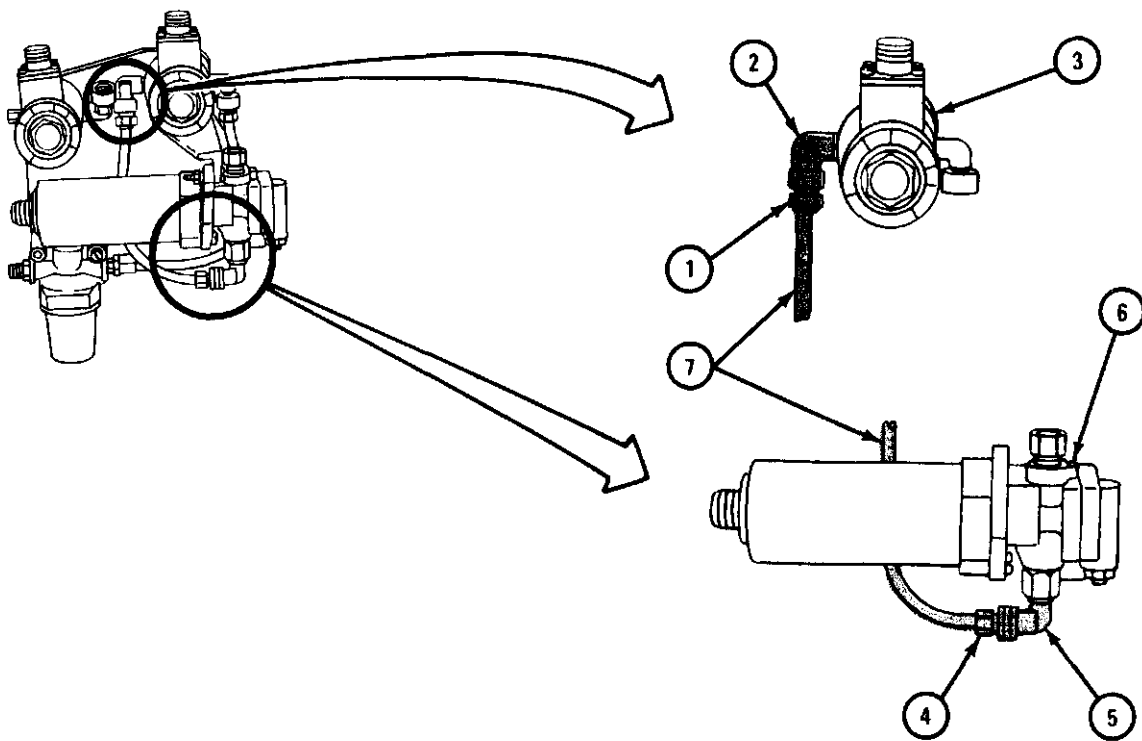

TA 087563

FRAME 8

1. Using screwdriver, unscrew two screws (1) and take fuel inlet solenoid valve (2) off of bracket (3). Keep lockwashers (4) on screws and set them aside.
2. Using screwdriver, unscrew two screws (5) and take fuel return solenoid valve (6) off of bracket (3). Keep lockwashers (7) on screws and set them aside.

GO TO FRAME 9

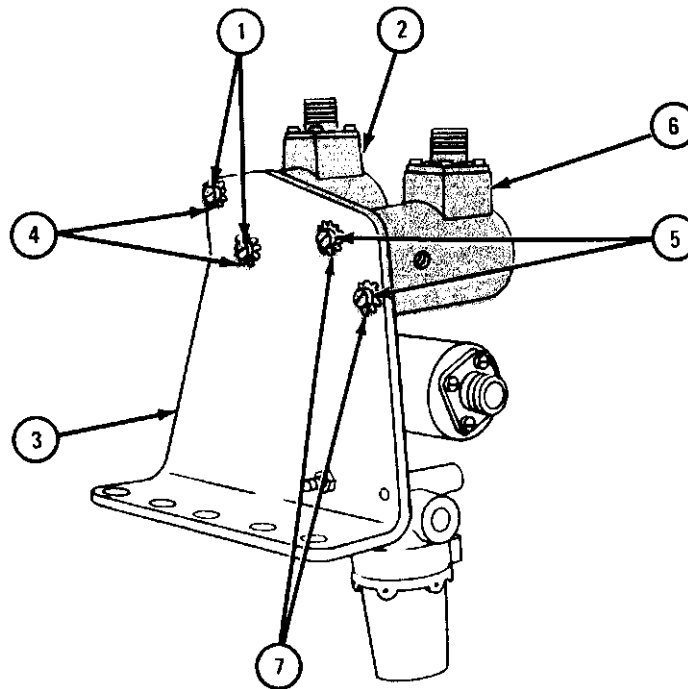

TA 087564

FRAME 9

NOTE

Before unscrewing elbow fittings (1, 2 and 4) from fuel solenoids, note position of each elbow fitting.

1. Using 7/16-inch open end wrench, unscrew elbow fittings (1 and 2) from fuel inlet solenoid valve (3).
2. Using 7/16-inch open end wrench, unscrew elbow (4) from fuel return solenoid Valve (5).

END OF TASK

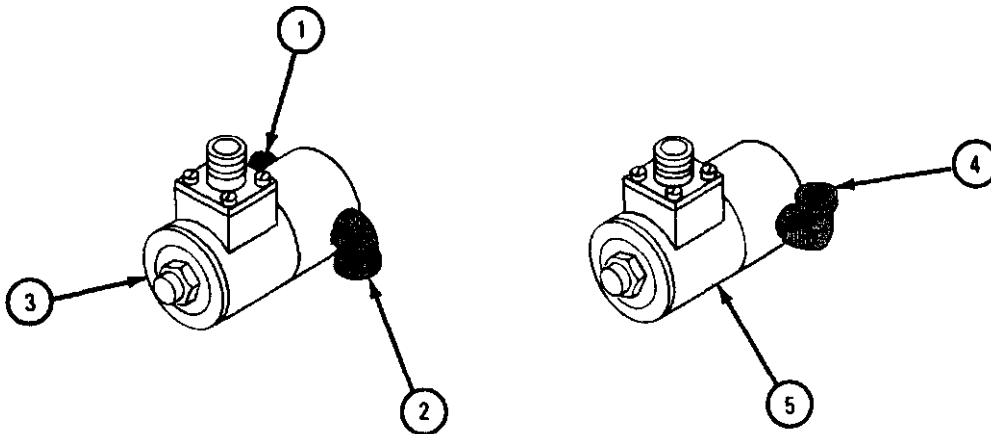

TA 087565

c. Replacement.WARNING

Dry cleaning solvent is flammable. Do not use near an open flame. Keep a fire extinguisher nearby when solvent is used. Use only in well-ventilated places. Failure to do this may result in injury to personnel and damage to equipment.

NOTE

Clean all fuel line fittings with solvent. Before putting fittings together, put a thin coat of sealer compound on threads of fittings.

FRAME 1

1. Screw two elbow fittings (1 and 2) into fuel inlet solenoid valve (3) and hand tighten.
2. Using 7/16-inch open end wrench, tighten elbow fittings (1 and 2) in fuel inlet solenoid valve. Position each elbow fitting as noted.
3. Screw one elbow fitting (4) into the hole on the side shown of fuel return solenoid valve (5) and hand tighten.
4. Using 7/16-inch open end wrench, tighten elbow fitting (4) in fuel return solenoid valve (5). Position elbow fitting as noted.

GO TO FRAME 2

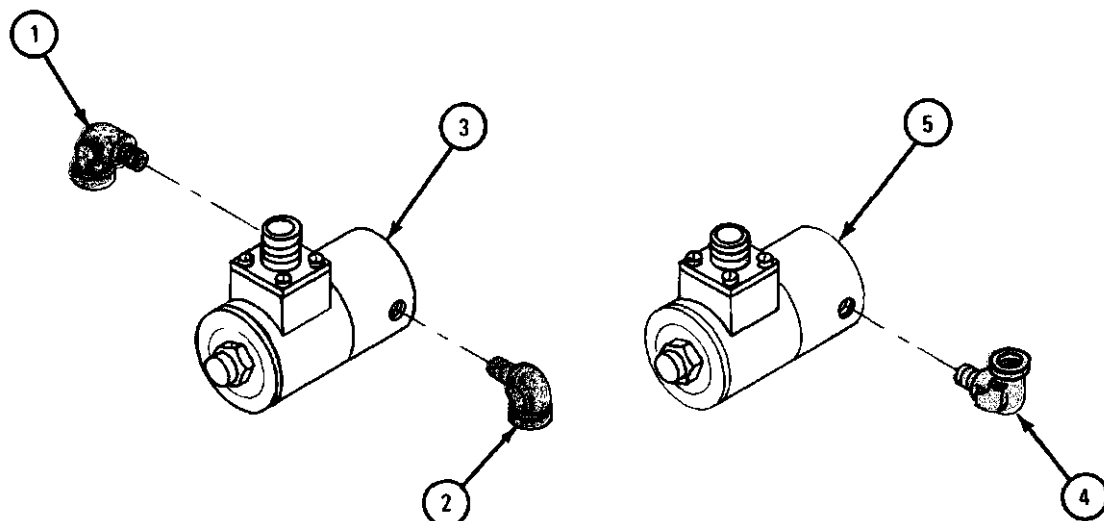

TA 087566

FRAME 2

1. Put fuel inlet solenoid valve (1) against bracket (2) and align mounting holes of solenoid with holes in bracket.
2. Using screwdriver, screw in and make fast solenoid valve (1) with two screws (3) and two lockwashers (4) to hold solenoid valve (1) to bracket (2).
3. Put fuel return solenoid valve (5) against bracket (2) and align mounting holes in solenoid with holes in bracket.
4. Using screwdriver, screw in and tighten two screws (3) and two lockwashers (4) to hold solenoid valve (5) to bracket (2).

GO TO FRAME 3

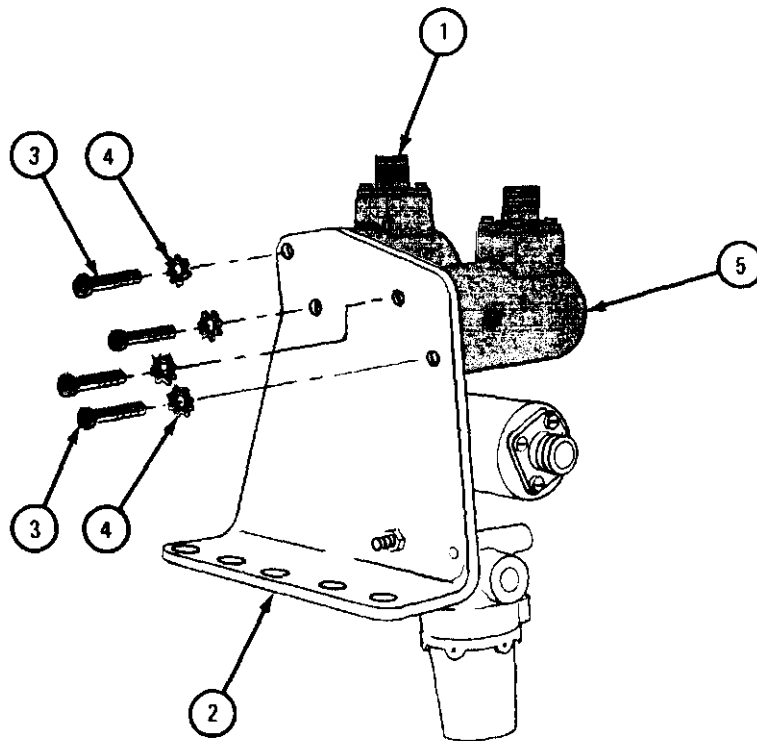

TA 087567

FRAME 3

1. Route fuel tube (1) as shown.
2. Screw coupling nut (2) into elbow (3) on fuel inlet solenoid (4). Using 7/16-inch open end wrench, tighten coupling nut.
3. Screw coupling nut (5) into elbow (6) on fuel pump (7). Using 7/6-inch open end wrench, tighten coupling nut.

GO TO FRAME 4

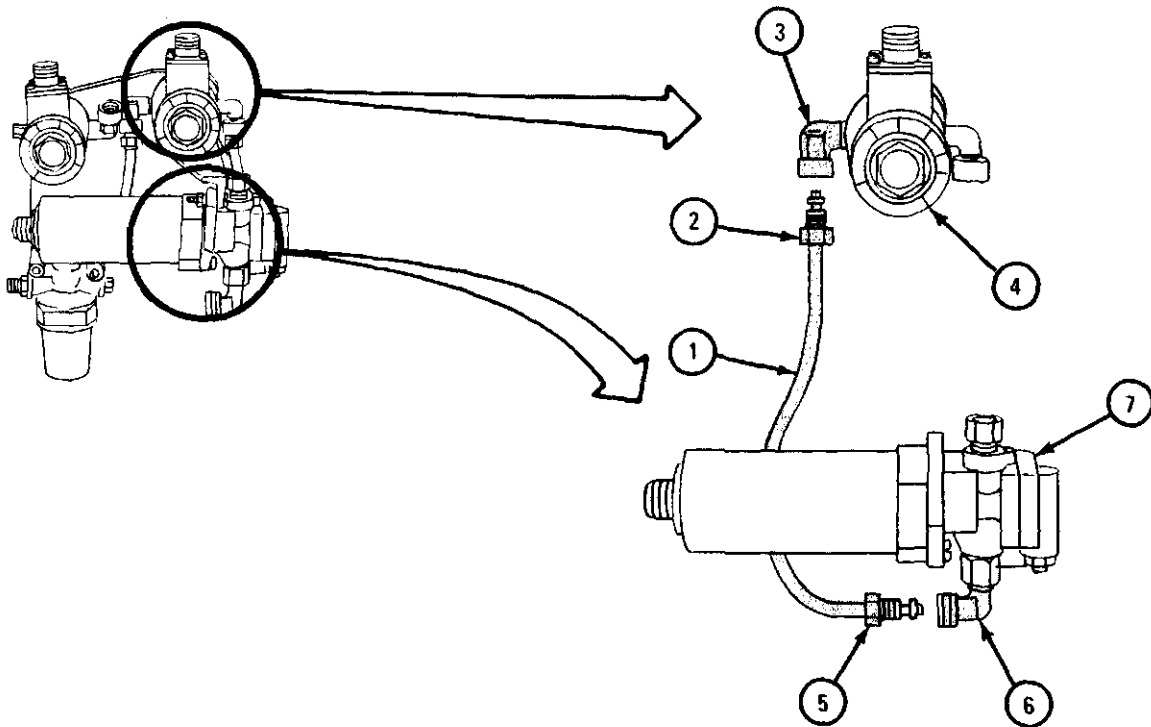

TA 087568

FRAME 4

1. Route fuel tube (1) as shown.
2. Screw coupling nut (2) into elbow (3) on fuel inlet solenoid (4). Using 7/16-inch open end wrench, tighten coupling nut.
3. Screw coupling nut (5) into adapter (6) on filter head (7). Using 7/16-inch open end wrench, tighten coupling nut.

GO TO FRAME 5

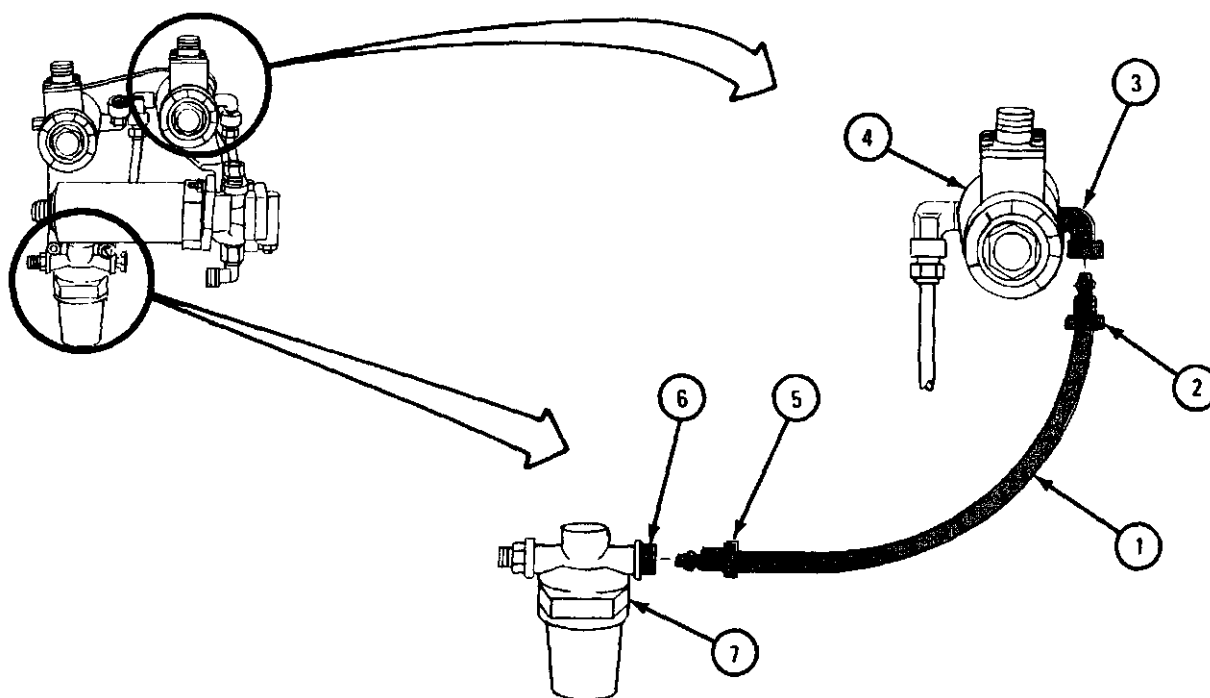

TA 087569

FRAME 5

1. Place bracket (1) in lower right side of engine compartment as shown. Align three holes in bracket with three holes on crankcase flange (2).
2. Using 9/16-inch wrench, screw in and tighten three bolts (3) with three lockwashers (4).

GO TO FRAME 6

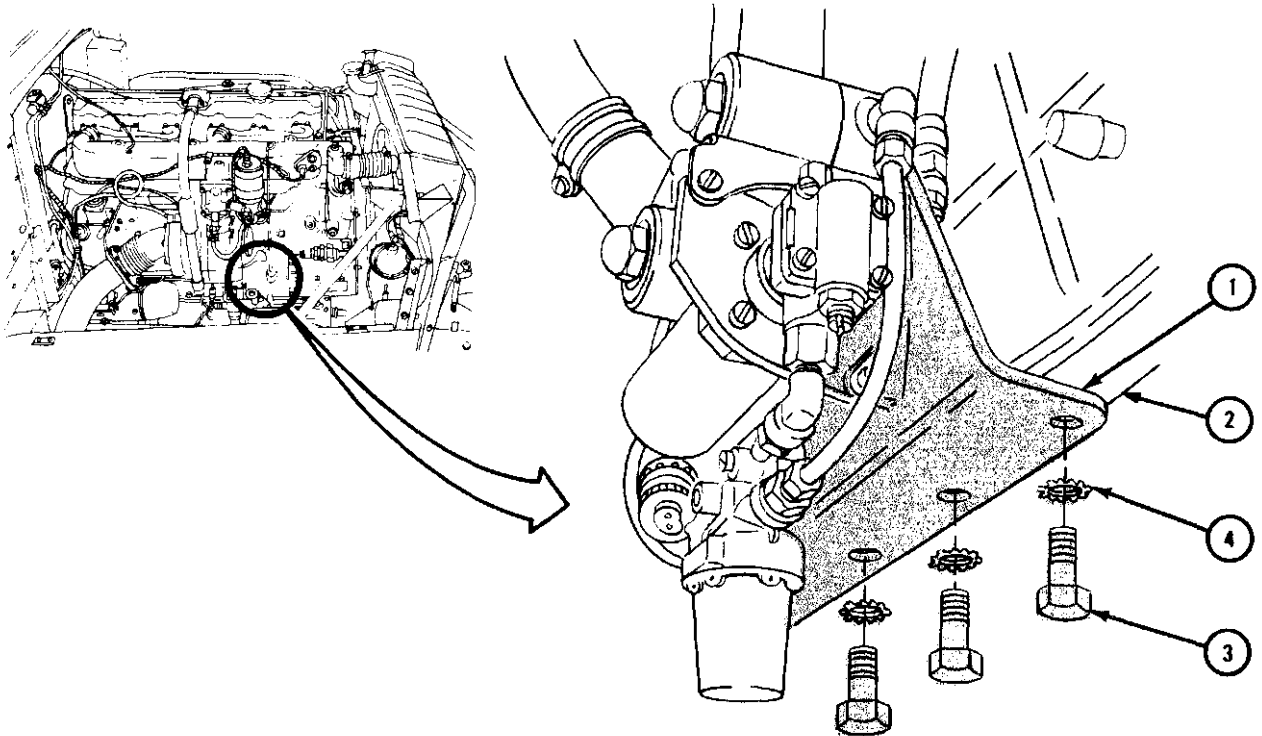

TA 047052

FRAME 6

1. Put screw (1) through hole in mounting bracket (2).
 2. Put ground lug (3), lockwasher (4) , and nut (5) on screw (1).
 3. Using 3/8-inch open end wrench and screwdriver, tighten nut (5).
- GO TO FRAME 7

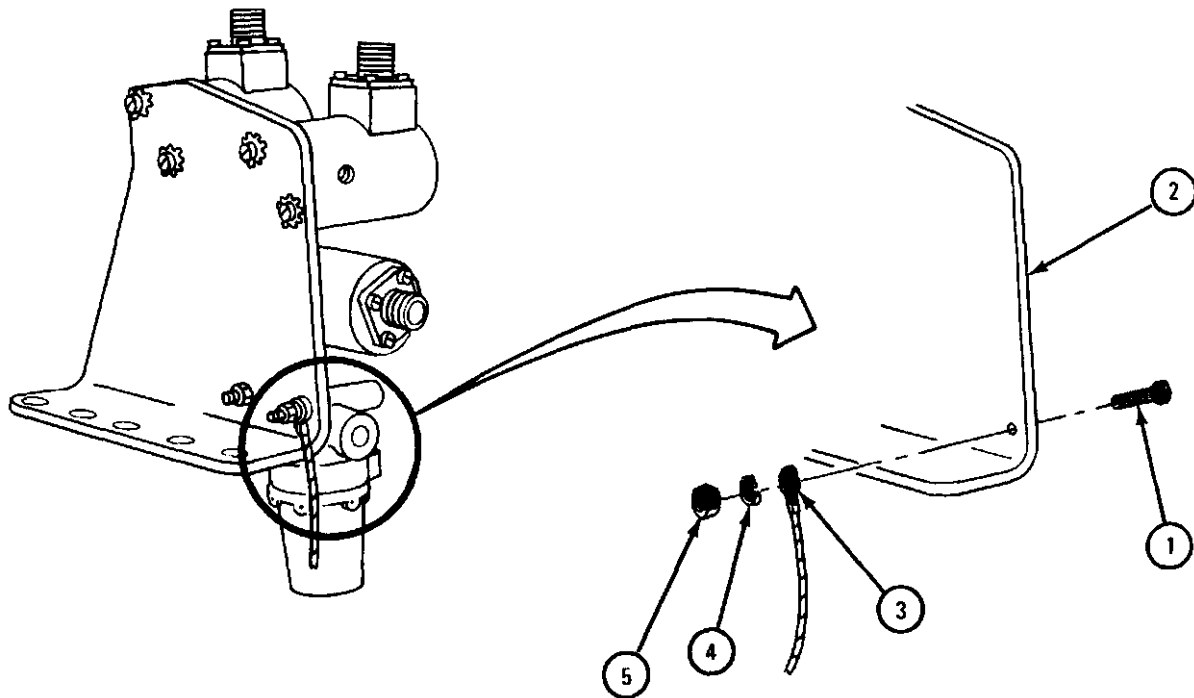

TA 087570

FRAME 7

1. Plug connector (1) into fuel pump (2) and tighten plug.
2. Plug connector (3) into fuel return solenoid valve (4) and tighten plug.
3. Plug connector (5) into fuel inlet solenoid valve (6) and tighten plug.

GO TO FRAME 8

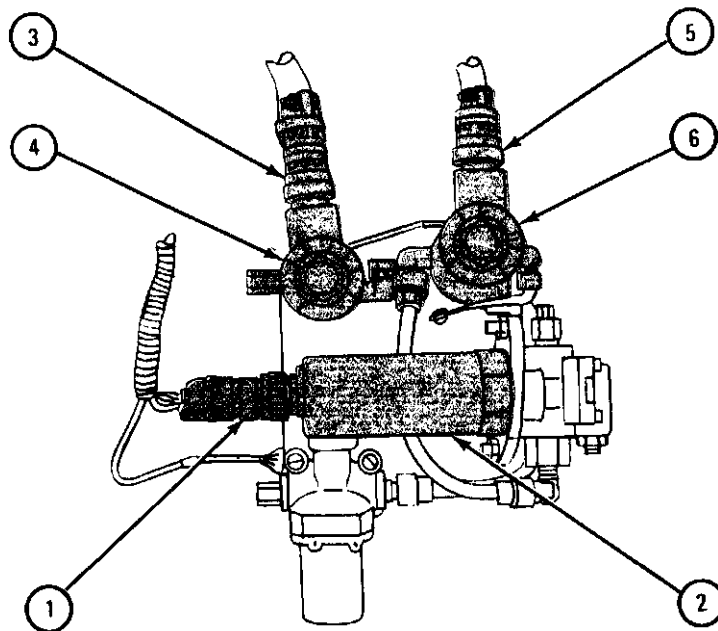

TA 087571

FRAME 8

1. Join fuel return tube (1) to elbow (2) on fuel return solenoid valve (3). Using 7/16-inch open end wrench, tighten coupling nut (4).
2. Join fuel supply tube (5) to union (6). Using 3/8-inch open end wrenches, tighten coupling nut (7).

GO TO FRAME 9

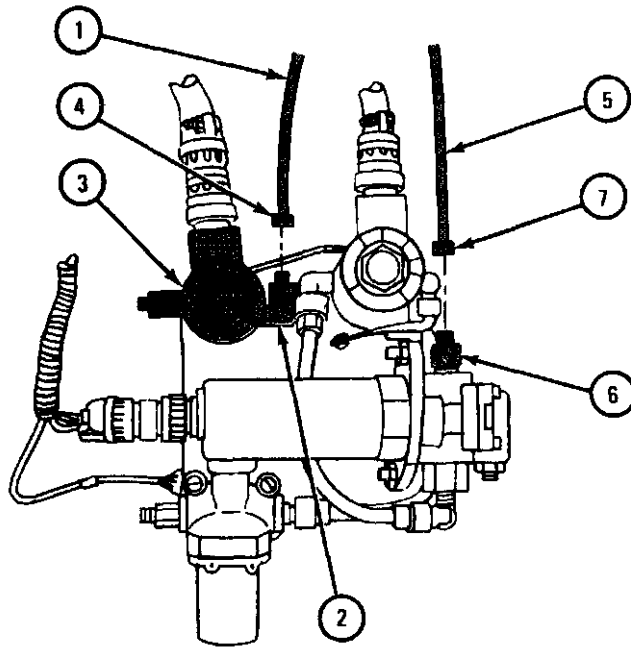

TA 087572

FRAME 9

1. Join fuel return tube (1) to adapter (2) on fuel return solenoid valve (3). Using 9/16-inch open end wrenches, tighten coupling nut (4).
2. Join fuel supply tube (5) to adapter (6) on fuel filter (7). Using 9/16-inch open end wrenches, tighten coupling nut (8).

GO TO FRAME 10

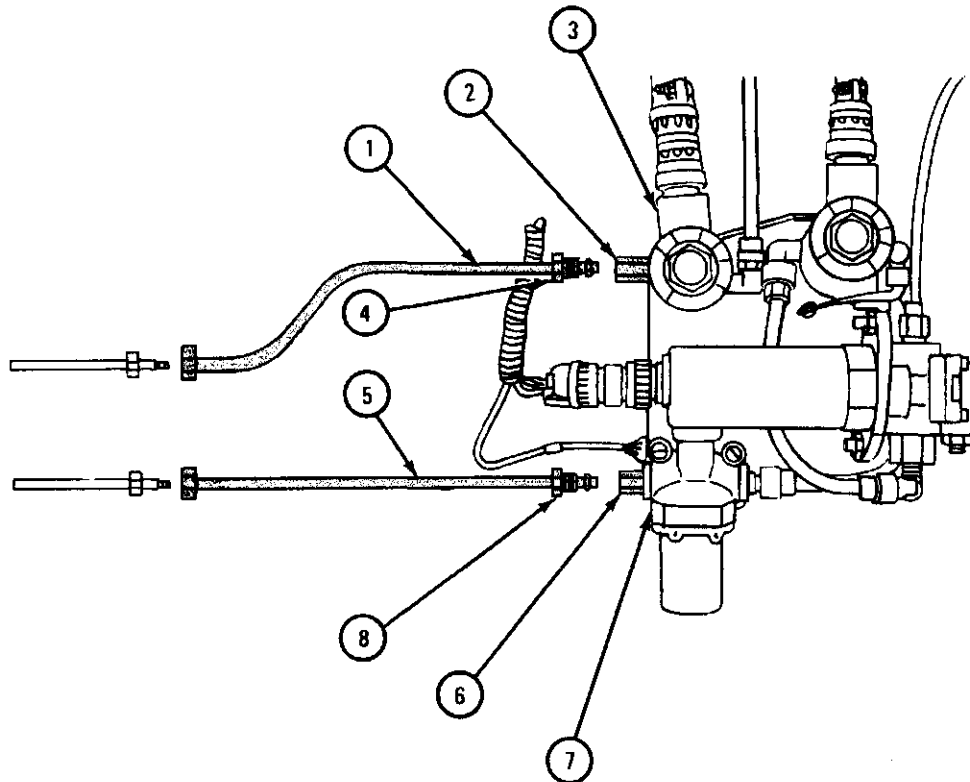

A 087573

FRAME 10

1. Using 9/16-inch open end wrench, hold nut (1) on fuel return hose (2).
2. Using 7/16-inch open end wrench, screw in and tighten nut (3) from return tube (4) into hose (2).
3. Using 9/16-inch open end wrench, hold nut (5) on fuel supply hose (6).
4. Using 7/16-inch open end wrench, screw in and tighten nut (7) from supply tube (8) into hose (6).

NOTE

Follow-on Maintenance Action Required:

1. Replace intake air cleaner. Refer to para 4-3.
2. Reconnect battery ground cable. Refer to para 7-58.
3. Operate engine manifold heater. Refer to TM 9-2320-209-10.
4. Check all manifold heater fuel lines and fittings for leaks.
5. Turn off engine manifold heater. Refer to TM 9-2320-209-10.

END OF TASK

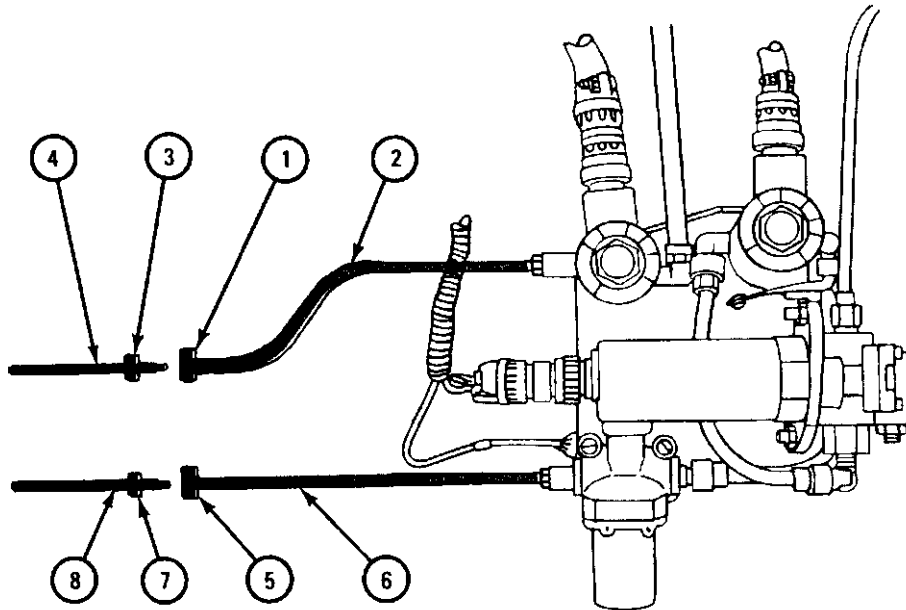

TA 082250

4-21. MANIFOLD HEATER NOZZLE AND VALVE ASSEMBLY REMOVAL AND REPLACEMENT .

TOOLS : 3/8-inch wrench
 7/16-inch wrench
 1-inch wrench

7/16-inch 6-point socket
 6-inch ruler

SUPPLIES : Container

PERSONNEL: One

EQUIPMENT CONDITION : Truck parked, engine off and cold, handbrake set.

a. Preliminary Procedure. Open hood and right side panel. Refer to TM 9-2320-209-10.

b. Removal.

FRAME 1

1. Put container under nozzle and valve assembly (1).
2. Using 3/8-inch wrench, unscrew and take off tube adapter (2) with tube (3).
3. Using 7/16-inch wrench, unscrew and take off tube adapter (5) with tube (6).
4. Using 1-inch wrench, loosen jamnut (7) and unscrew and take off nozzle and valve assembly (1).

END OF TASK

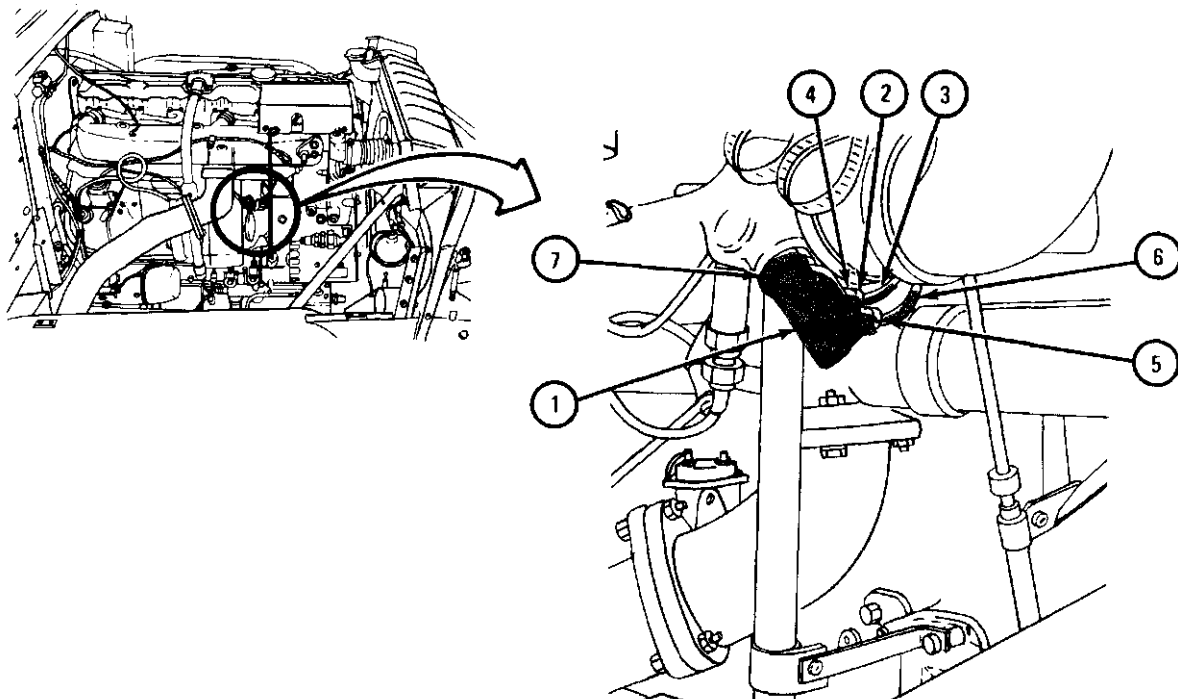

TA 083339

c. Replacement.

FRAME 1

1. Screw on and hand tighten nozzle and valve assembly (1) until there is 1/2-inch clearance between nozzle and valve assembly and housing (2).
2. Using 1-inch wrench tighten jamnut (3).
3. Using 7/16-inch 6-point socket, screw in and tighten inlet adapter (4).
4. Using 3/8-inch wrench, screw on and tighten tube adapter (5) with tube (6).
5. Using 7/16-inch wrench, screw on and tighten tube adapter (7) with tube (8).
6. Put fuel from container in approved disposal area.

NOTE

Follow-on Maintenance Action Required:

Close hood and right side panel. Refer to TM 9-2320-209-10.

END OF TASK

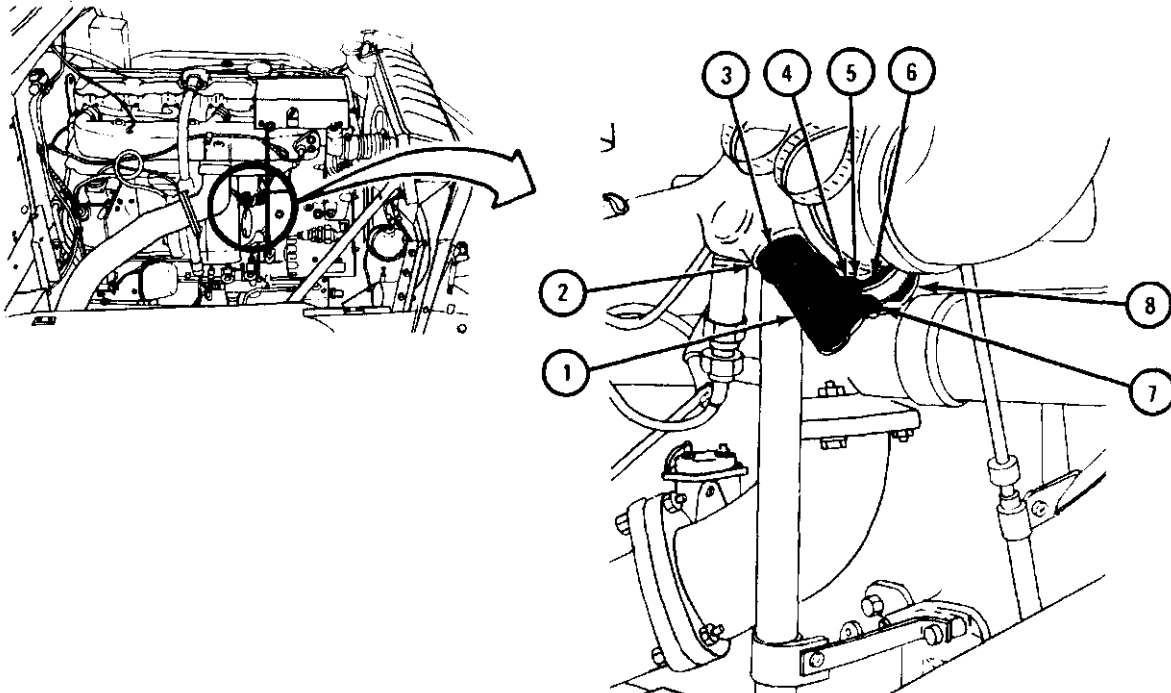

TA 101736

FRAME 2

1. Using 1/2-inch socket wrench, unscrew and take off two nuts (1). Take off two lockwashers (2).
- 2* Take ignition unit (3) off manifold studs (4) .
3. Slide two cIamps (5) off ignition unit (3).

END OF TASK

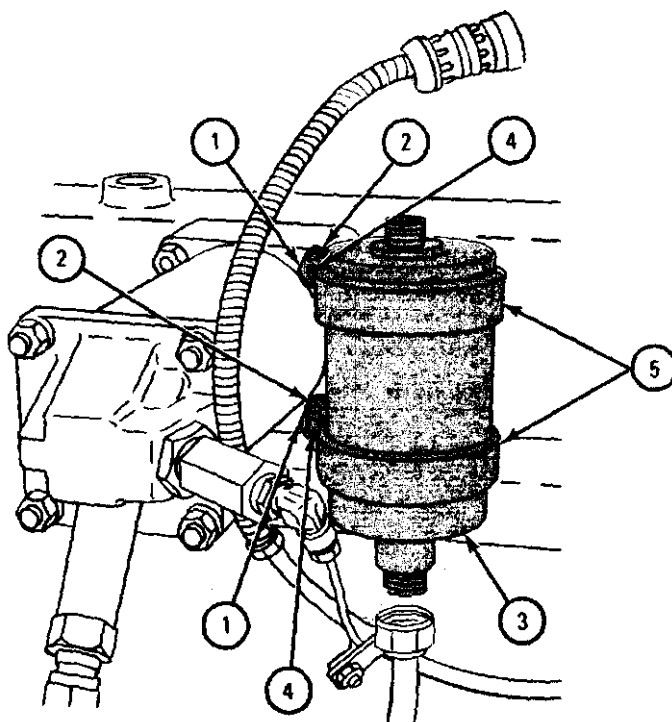

TA 047400

c. Replacement.

FRAME 1

1. Slide two clamps (1) on ignition unit (2). Slide one clamp up to ridge at top of ignition unit.
2. Set spacing between clamps (1) so holes in clamps line up with two threaded studs (3).
3. Put two clamps (1) over threaded studs (3). Put two lockwashers (4) on studs and screw on two nuts (5). Using 1/2-inch wrench, tighten nuts.

GO TO FRAME 2

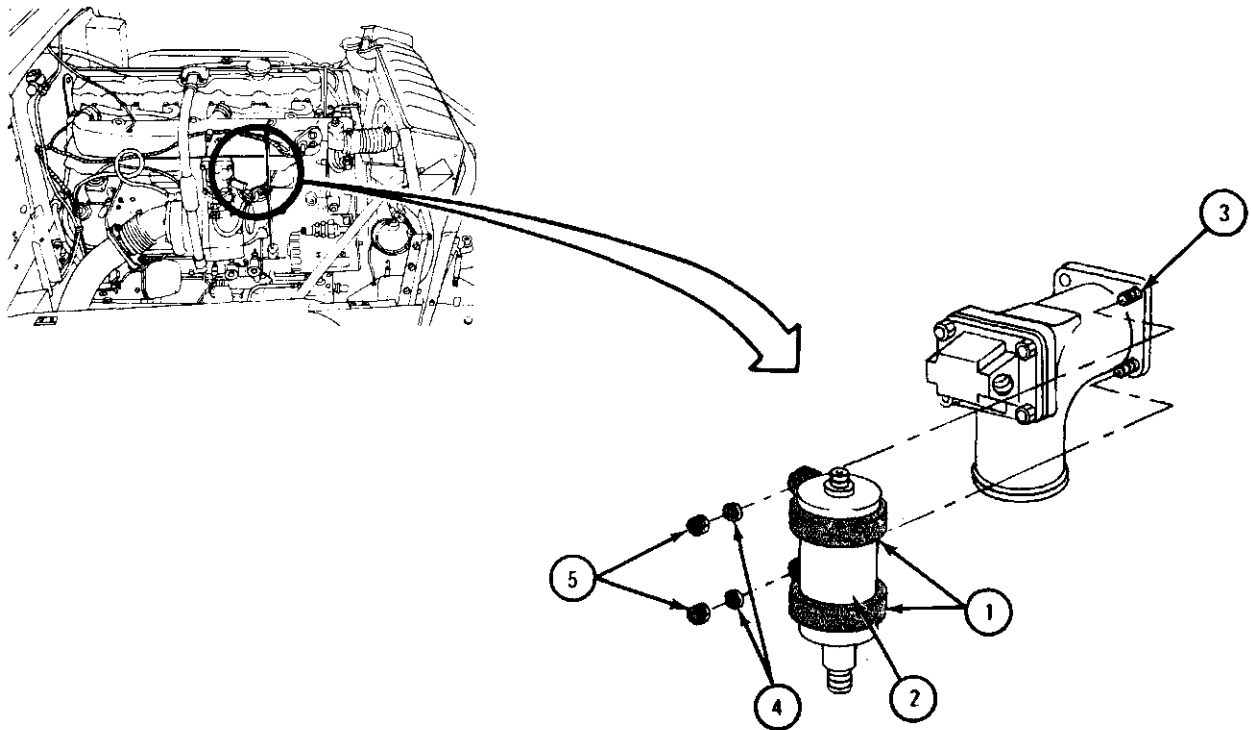

TA 047057

FRAME 2

1. Plug ignition lead (1) into connector on bottom of ignition unit (2). Using 7/8-inch wrench, tighten nut (3).
2. Plug connector (4) into connector on top of ignition unit (2). Screw connector on tightly.

NOTE

Follow-on Maintenance Action Required:

Close hood and right side panel. Refer to TM 9-2320-209-10.

END OF TASK

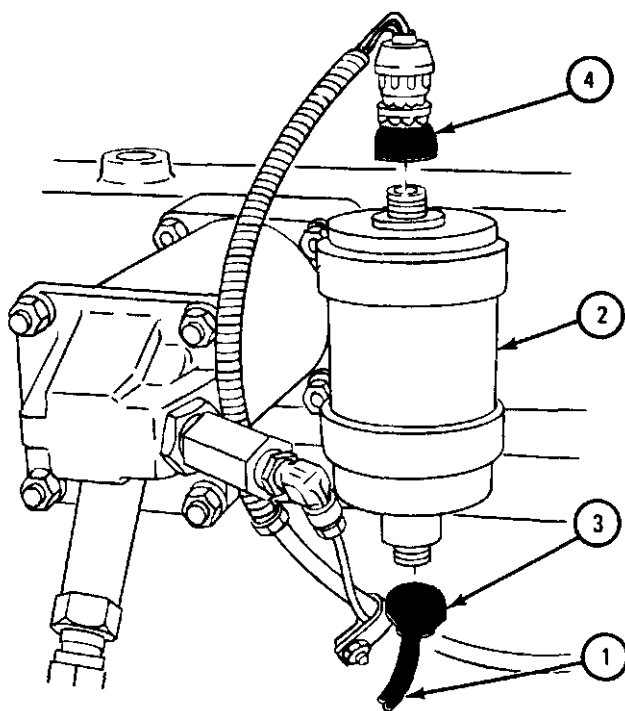

TA 087575

4-23. MANIFOLD HEATER (TOP-MOUNTED, COVERED) SPARK PLUG REMOVAL AND REPLACEMENT.

TOOLS : 3/4-inch wrench
7/8-inch wrench

SUPPLIES: None

PERSONNEL: One

EQUIPMENT CONDITION: Truck parked, engine off, handbrake set.

a. Preliminary Procedure. Open hood and right side Panel. Refer to TM 9-2320-209-10.

b. Removal.

FRAME 1

1. Using 3/4-inch wrench, unscrew and take off electrical cable connector (1) from spark plug (2) .
2. Using 7/8-inch, unscrew and take off spark plug (2) . Take off gasket (3) .

END OF TASK

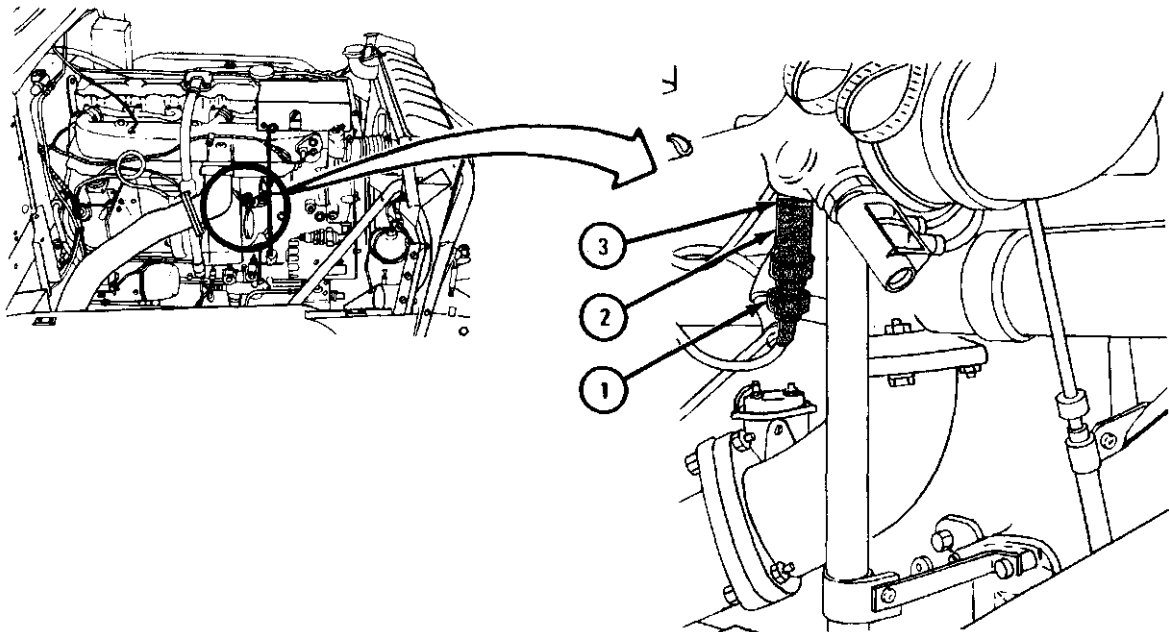

TA 083337

c. Replacement.

FRAME 1

1. Put gasket (1) on spark plug (2). Using 7/8-inch wrench, screw on and tighten spark plug (2).
2. Using 3/4-inch wrench, screw on and tighten electrical cable connector (3) to spark plug (2).

NOTE

Follow-on Maintenance Action Required:

Close hood and right side panel. Refer to TM 9-2320-209-10.

END OF TASK

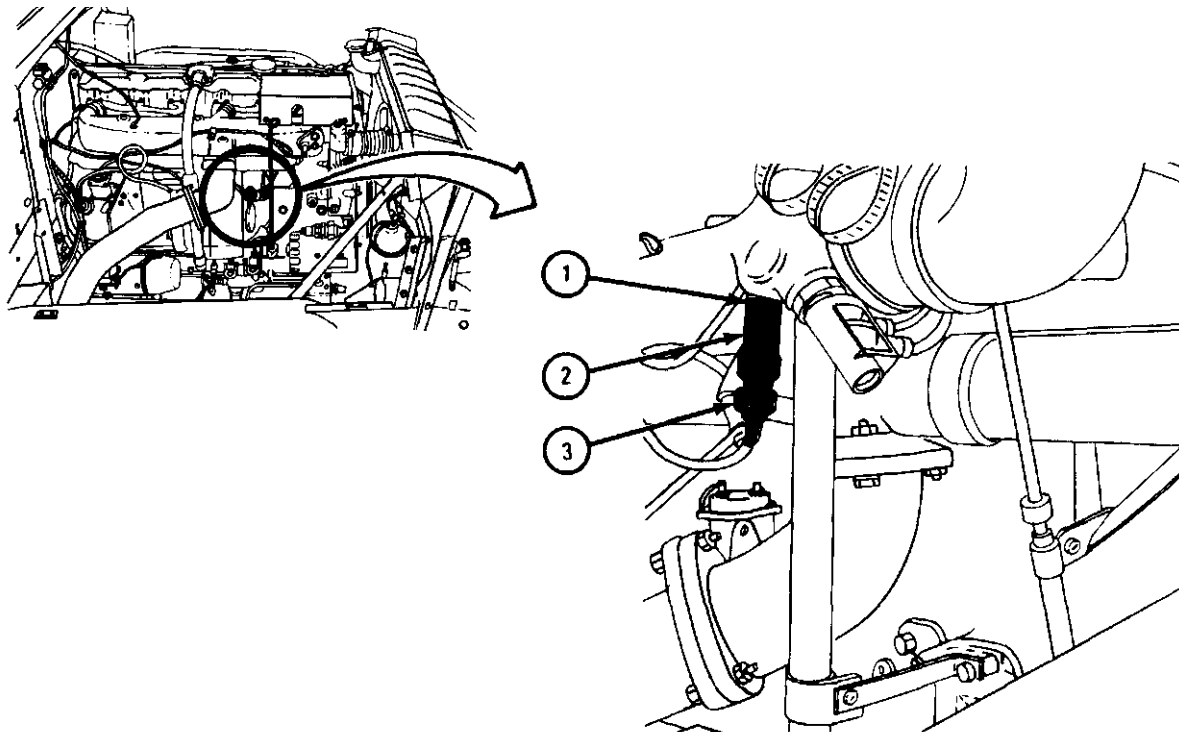

TA 083338

4-24. MANIFOLD HEATER (TOP-MOUNTED, COVERED) FUEL FILTER REMOVAL AND REPLACEMENT.

TOOLS: 7/16-inch wrench
9/16-inch wrench
11/16-inch wrench

SUPPLIES: None

PERSONNEL: One

EQUIPMENT CONDITION: Truck parked, engine off, handbrake set.

Preliminary Procedure. Open hood and left side panel. Refer to TM 9-2320-209-10.

b. Removal.

FRAME 1

1. Using 9/16-inch wrench, hold adapter (1). Using 7/16-inch wrench, unscrew tube fitting (2).
2. Using 9/16-inch wrench, hold elbow (3). Using 9/16-inch wrench, unscrew and take off adapter (1).
3. Using 11/16-inch wrench, hold filter (4). Using 9/16-inch wrench, unscrew and take off elbow (3).
- 4* Using 11/16-inch wrench, hold filter (4). Using 7/16-inch wrench unscrew and take off tube fitting (5).
5. Using 9/16-inch wrench, and holding filter (4), unscrew and take off capscrew (6).
6. Take off lockwasher (7) and fuel filter (4).

END OF TASK

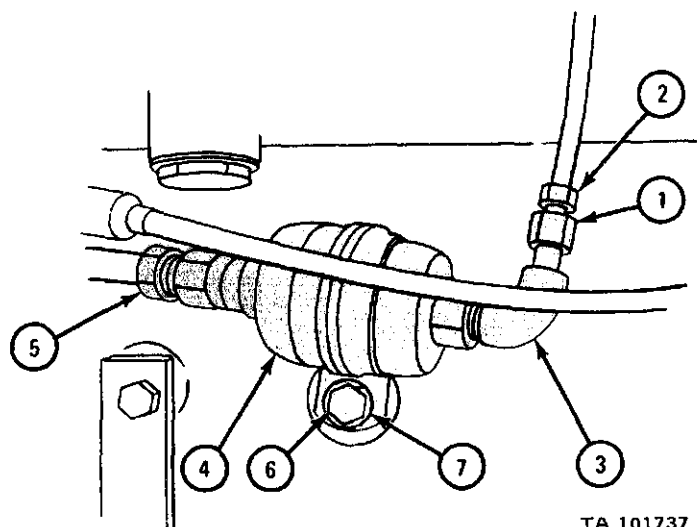
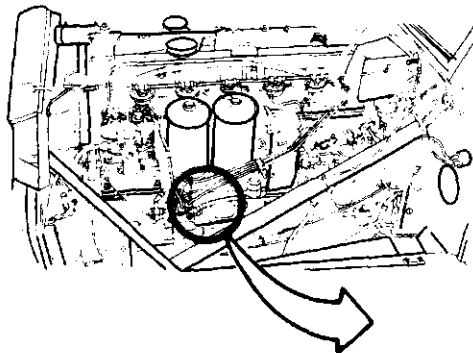

TA 101737

c. Replacement.

FRAME 1

1. Put filter (1) in place and align screw hole. Using 9/16 inch wrench, screw in and tighten capscrew (2) and lockwasher (3)
2. Using 11/16-inch wrench, hold filter (1). Using 7/16-inch wrench, screw on and tighten tube fitting (4).
3. Using 11/16-inch wrench, hold filter (1). Using 9/16-inch wrench, screw in and tighten elbow (5).
4. Using 9/16-inch wrench, screw in and tighten adapter (6).
5. Using 9/16-inch wrench, hold adapter (6). Using 7/16-inch wrench, screw in and tighten tube fitting nut (7).

NOTE

Follow-on Maintenance Action Required:

Close hood and left side panel. Refer to TM 9-2320-209-10.

END OF TASK

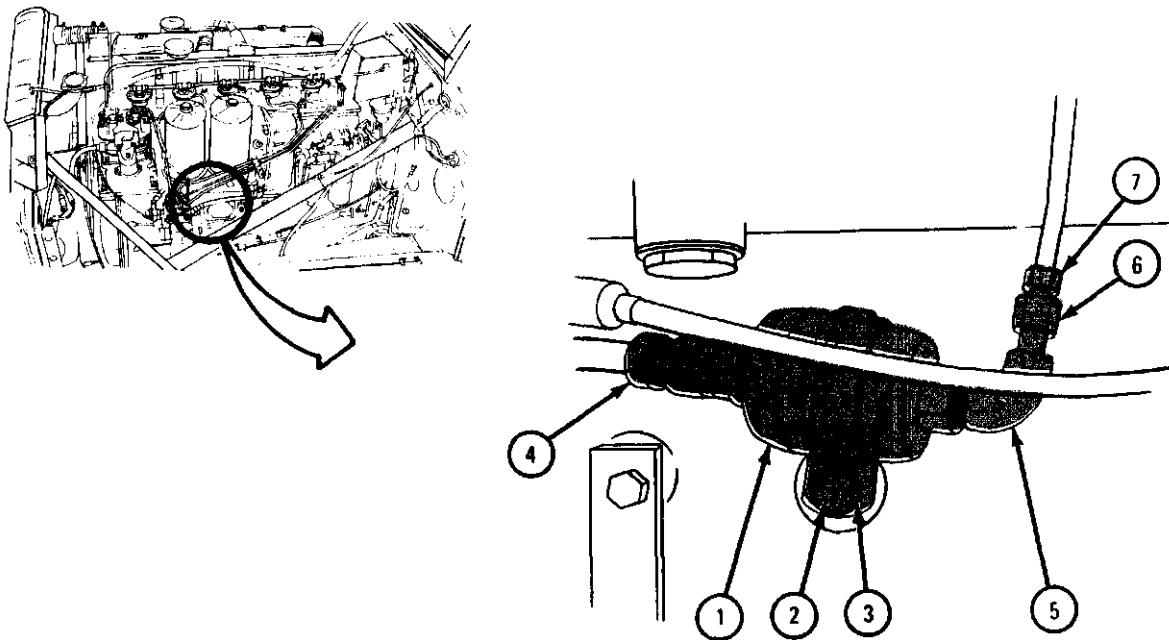

4-25. INTAKE MANIFOLD (TOP-MOUNTED, COVERED) FLAME HEATER AND ELBOW REMOVAL AND REPLACEMENT (TRUCKS WITH ENGINES LD465-1, LD465-1C, AND LDT 465-1C).

NOTE

This task is the same for all three model engines, but on some engines intake manifold heater elbow is mounted in a different position. This task is shown for the LD 465-1C engine.

TOOLS : 3/8-inch open end wrench
7/16-inch open end wrench
1/2-inch open end wrench
3/4-inch open end wrench
7/8-inch open end wrench
1-inch open end wrench
9/16-inch open end wrench
3/8-inch flat-tip screwdriver

SUPPLIES : Spark plug gasket
Manifold heater elbow gasket

PERSONNEL : One

EQUIPMENT CONDITION : Truck parked, engine off, handbrake set.

a. Preliminary Procedures.

- (1) Open hood. Refer to TM 9-2320-209-10.
- (2) Disconnect battery ground cable. Refer to para 7-58,

b. Removal.

FRAME 1

1. Using screwdriver, loosen two hose clamps (1).
2. Take off air induction hose assembly (2).

GO TO FRAME 2

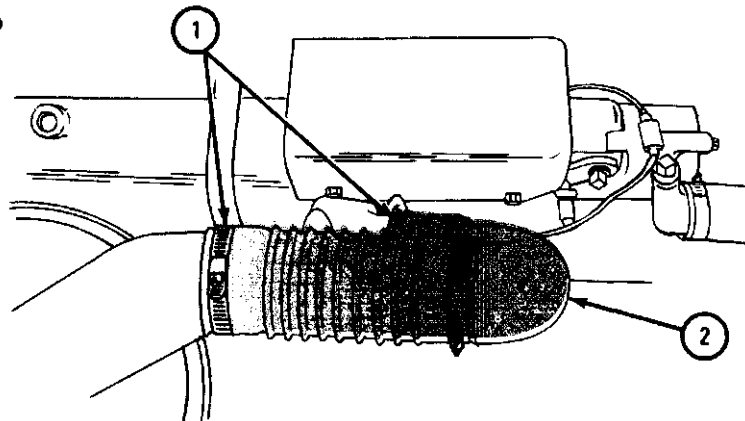
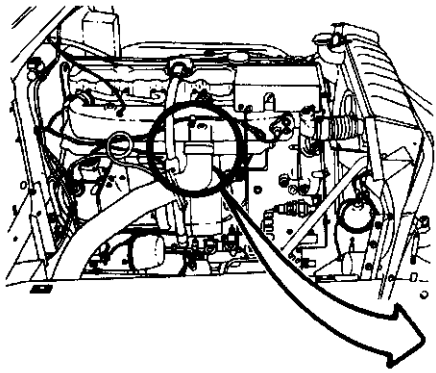

TA 051715

FRAME 2

1. Using 3/4-inch wrench, unscrew nut (1) and take off ignition cable and conduit assembly (2).
2. Using 7/8-inch wrench, unscrew and take out spark plug (3) and gasket (4).
Throw gasket away.

GO TO FRAME 3

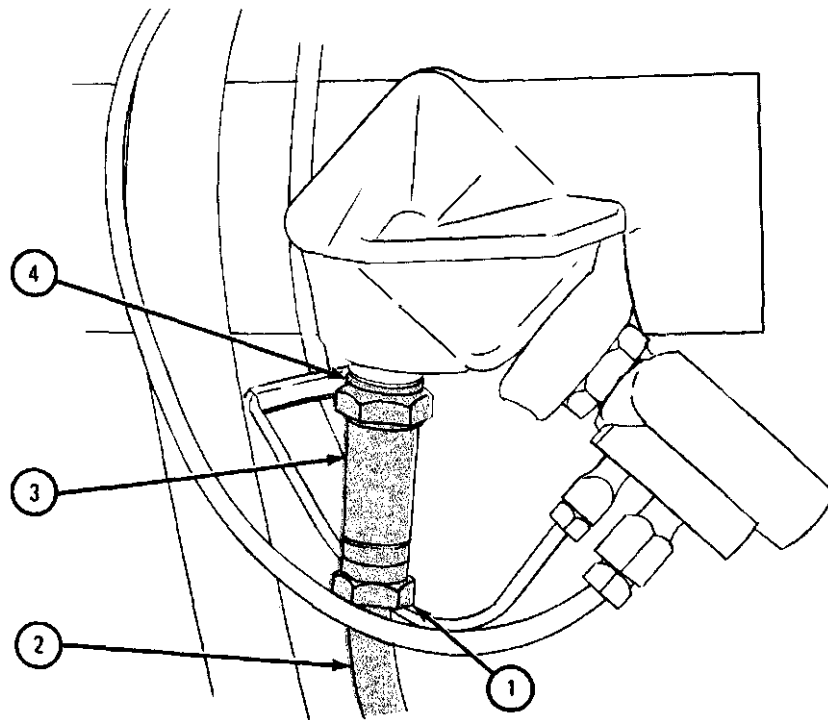

TA 051716

FRAME 3

1. Using 9/16-inch wrench, hold adapter (1). Using 7/16-inch wrench, unscrew and take off inverted nut and tube (2).
2. Using 9/16-inch wrench, unscrew and take off adapter (1).
3. Using 7/16-inch wrench, hold adapter (3). Using 3/8-inch wrench, unscrew and take off inverted nut and tube (4).
4. Using 7/16-inch wrench, unscrew and take off adapter (3).
5. Using 1-inch wrench, loosen locknut (5). Unscrew and take off nozzle and check valve assembly (6).

GO TO FRAME 4

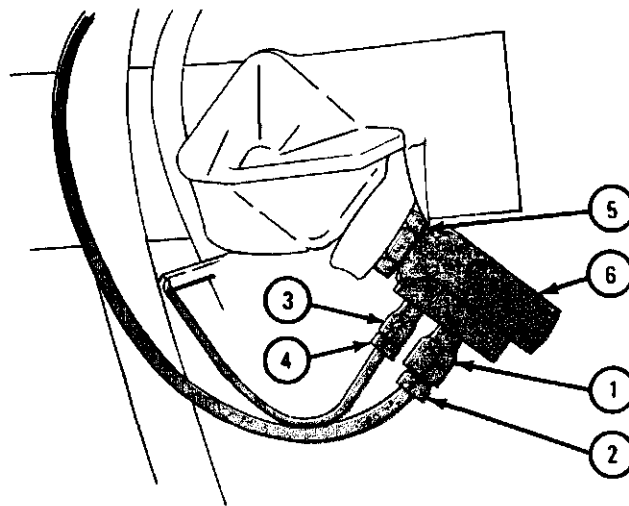

TA 051717

FRAME 4

1. Using 1/2-inch wrench , unscrew and take out four capscrews (1).

2. Lift off cover (2) .

GO TO FRAME 5

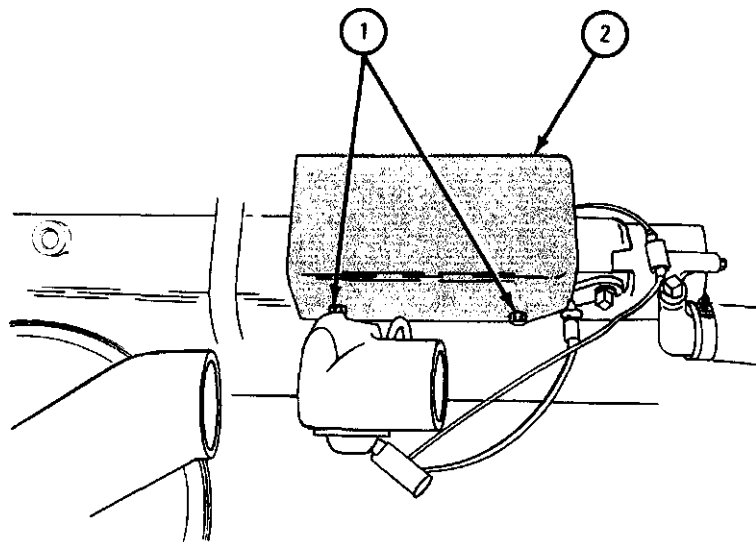

TA 051718

FRAME 5

1. Using 1/2-inch wrench, loosen three capscrews (1) until intake manifold heater elbow (2) can be taken off mounting studs.

GO TO FRAME 6

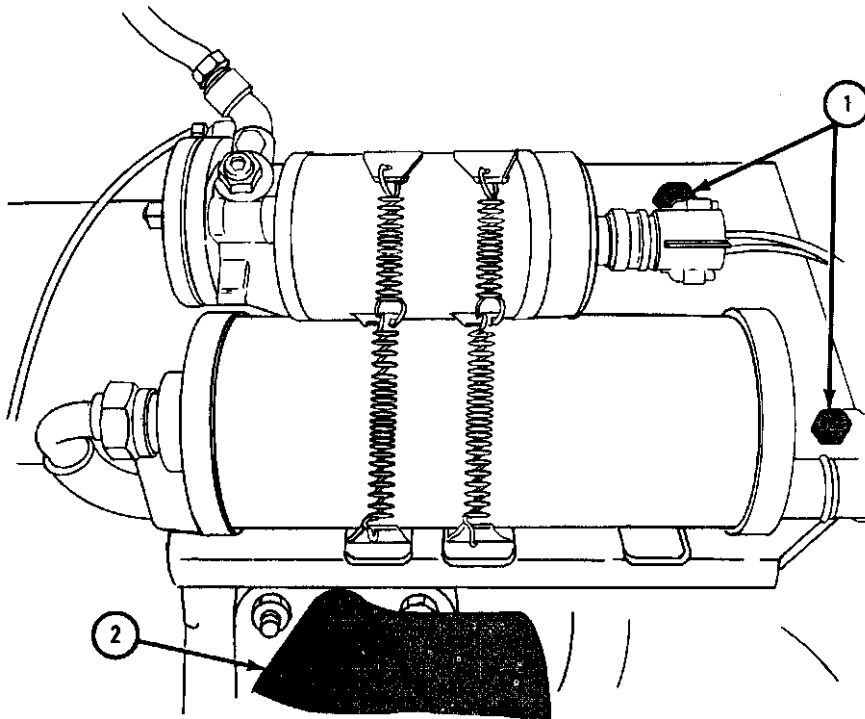

TA 051719

FRAME 6

1. Using 1/2-inch wrench, unscrew and take off four nuts and lockwashers (1) .
2. Pull intake manifold heater elbow (2) off intake manifold (3).
3. Take off intake manifold heater elbow gasket (4). Throw away gasket.

END OF TASK

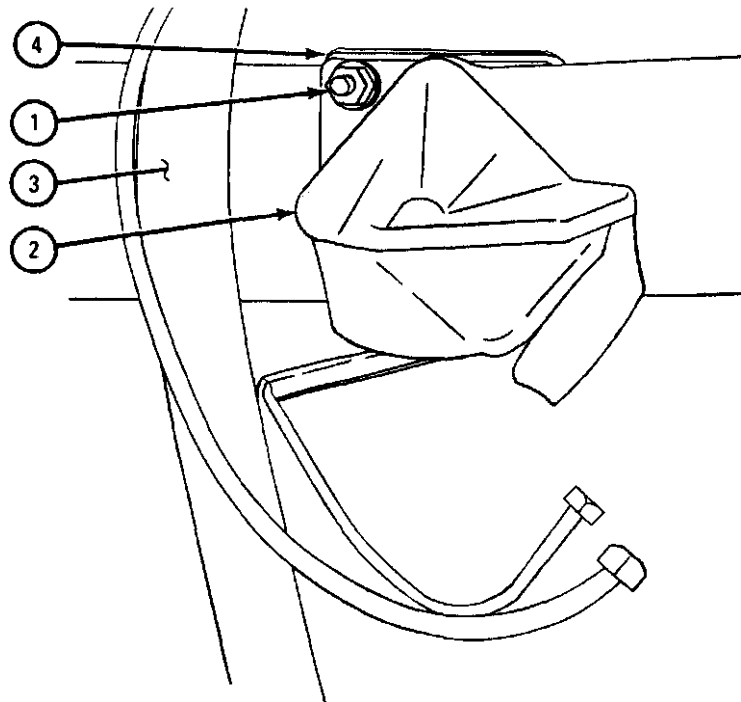

TA 051720

c. Replacement.

FRAME 1

1. Place intake manifold heater elbow gasket (1) on intake manifold heater elbow studs (2).
 2. Put intake manifold heater elbow (3) on intake manifold studs (2).
 3. Using 1/2-inch wrench, screw on and tighten four nuts and lockwashers (4).
- GO TO FRAME 2

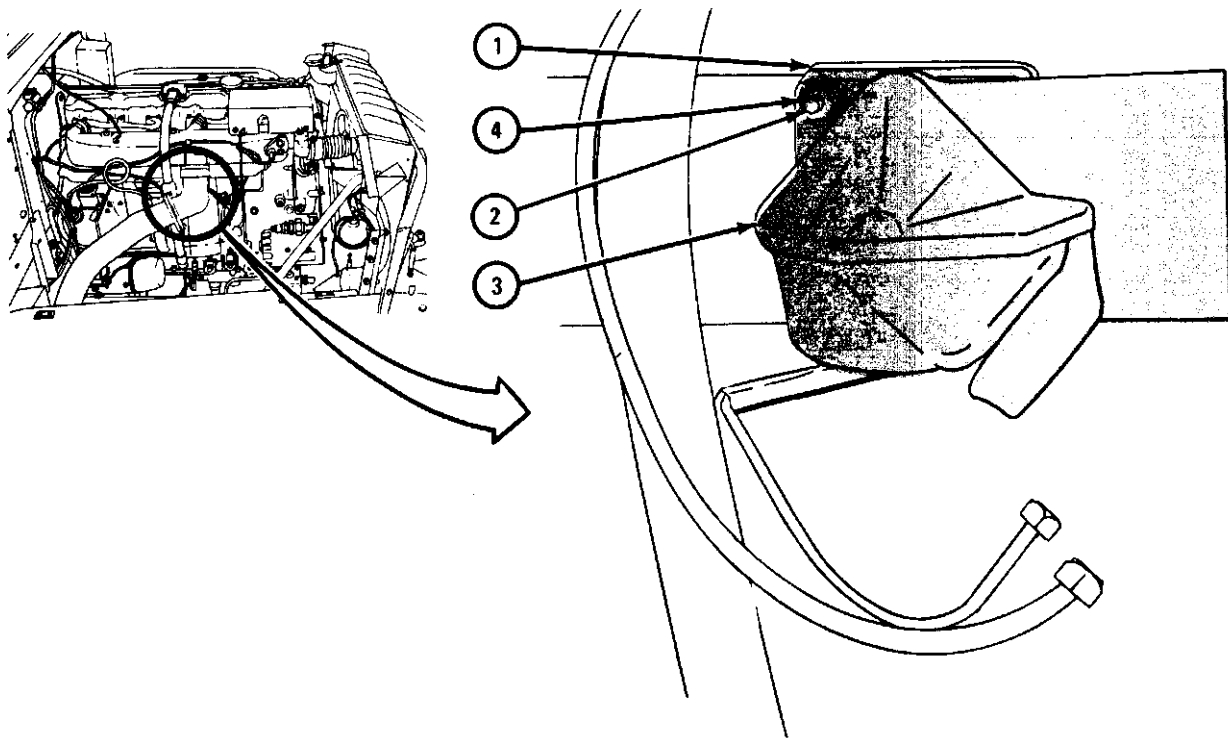

TA 051721

FRAME 2

1. Put gasket (1) on sparkplug (2). Using 7/8-inch wrench, screw in and tighten spark plug.
2. Put ignition cable and conduit assembly terminal (3) in sparkplug (2). Using 3/4-inch wrench, screw on and tighten nut (4).

GO TO FRAME 3

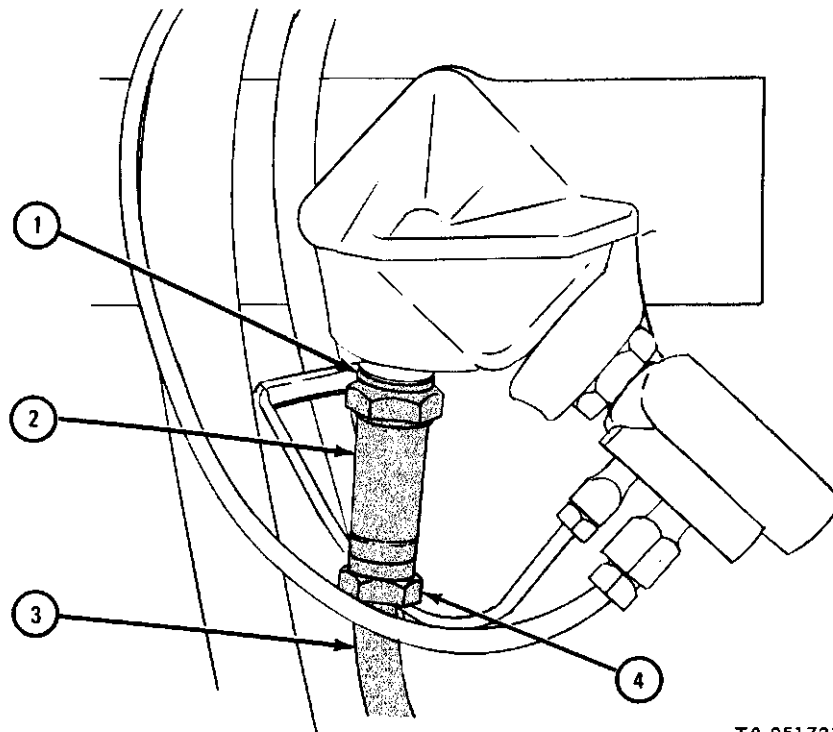

TA 051723

FRAME 3

1. Using 1/2-inch wrench, tighten three capscrews (1).

GO TO FRAME 4

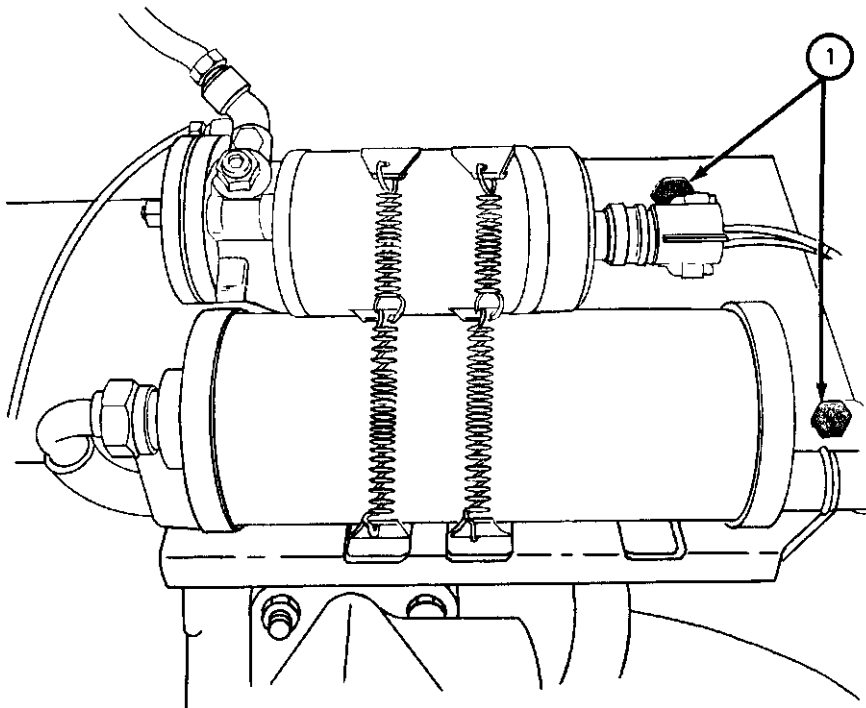

TA 051724

FRAME 4

1. Place cover (1) on support bracket. Using 1/2-inch wrench, screw in and tighten four capscrews (2) .

GO TO FRAME 5

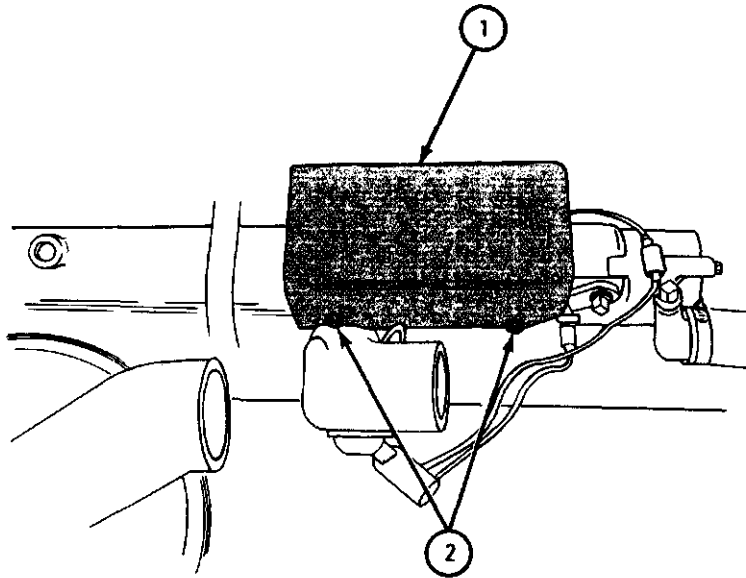

T4 051725

FRAME 5

1. Put air induction hose assembly (1) on intake manifold heater elbow (2) and air cleaner outlet (3).
2. Using screwdriver, tighten two hose clamps (4).

NOTE

Follow-on Maintenance Action Required:

1. Reconnect battery ground cable. Refer to para 7-58.
2. Close hood. Refer to TM 9-2320-209-10.

END OF TASK

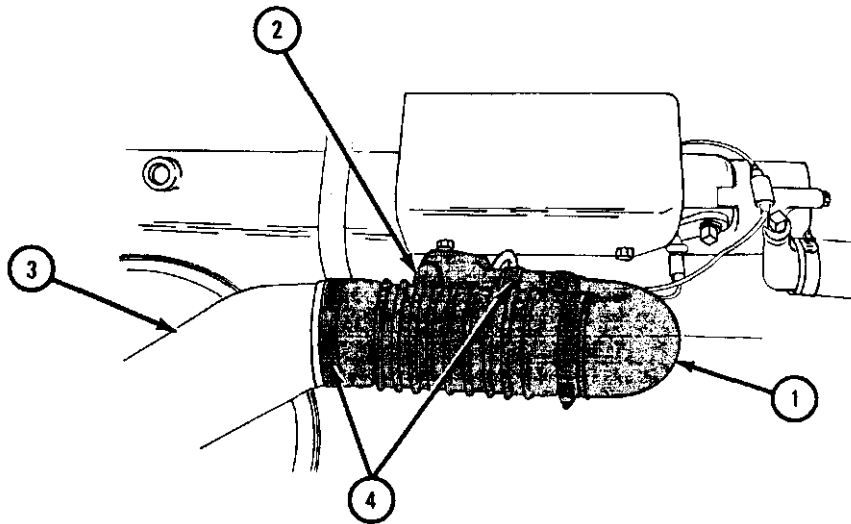

TA 051726

4-26. MANIFOLD FLAME HEATER (TOP-MOUNTED, COVERED) FUEL PUMP AND IGNITION UNIT REMOVAL AND REPLACEMENT (TRUCKS WITH ENGINES LD 465-1, LD 465-1C , AND LDT 465-1C).

TOOLS : 1/2-inch combination box and open end wrench
7/16-inch combination box and open end wrench
3/8-inch combination box and open end wrench
7/8-inch wrench
Pliers

SUPPLIES : None

PERSONNEL: One

EQUIPMENT CONDITION : Truck parked, engine off, handbrake set.

a. Preliminary Procedures.

(1) Open hood. Refer to TM 9-2320-209-10.

(2) Disconnect battery ground cable. Refer to para 7-58.

b. Removal.

FRAME 1

1. Using 1/2-inch wrench, unscrew and take out four capscrews and lock-washers (1). Take off cover (2).

GO TO FRAME 2

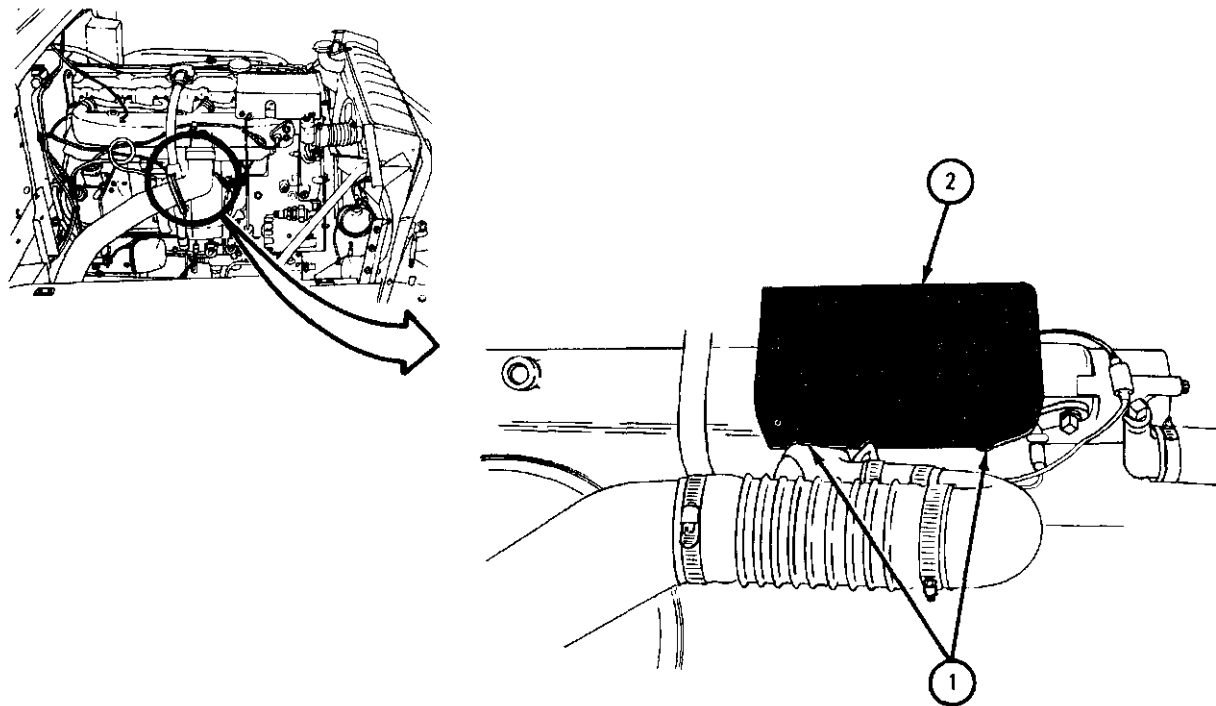

TA 051727

FRAME 2

1. Using 7/16-inch wrench, unscrew and take off inverted nut and tube (1).
2. Using 3/8-inch wrench, unscrew and take off inverted nut and tube (2).
3. Unscrew wiring harness connector (3) off fuel pump (4).
4. Push down on fuel pump clamp assembly (5) and unhook it from exciter and support bracket assembly (6).
5. Lift off fuel pump (4).

GO TO FRAME 3

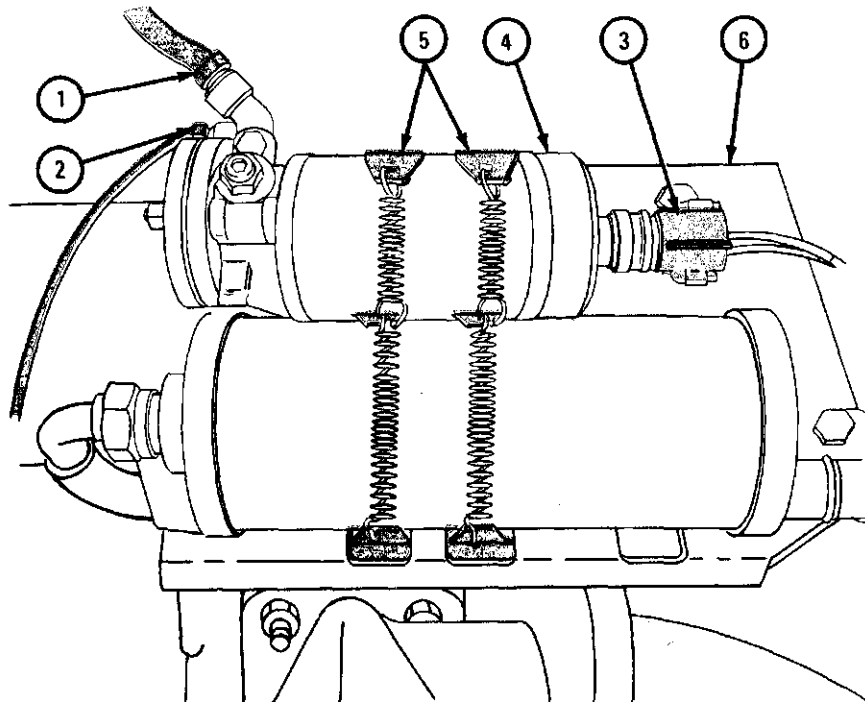

TA 051728

FRAME 3

WARNING

Do not touch any uninsulated or live connections during this task. Voltage output of ignition unit can cause dangerous electrical shock. Read warning notice on ignition unit.

1. Using 7/8-inch wrench, unscrew nut (1) from ignition unit (2) and take out ignition cable and conduit assembly plug (3).
2. Unscrew wiring harness connector (4) off ignition unit (2).
3. Push down ignition unit clamp assembly (5) and unhook it from support bracket assembly (6). Take off ignition unit (2) .
4. Using 1/2-inch wrench, unscrew and take out three capscrews and lockwashers (7), and lift support bracket assembly (6) and wiring harness (4) off intake manifold (8).

END OF TASK

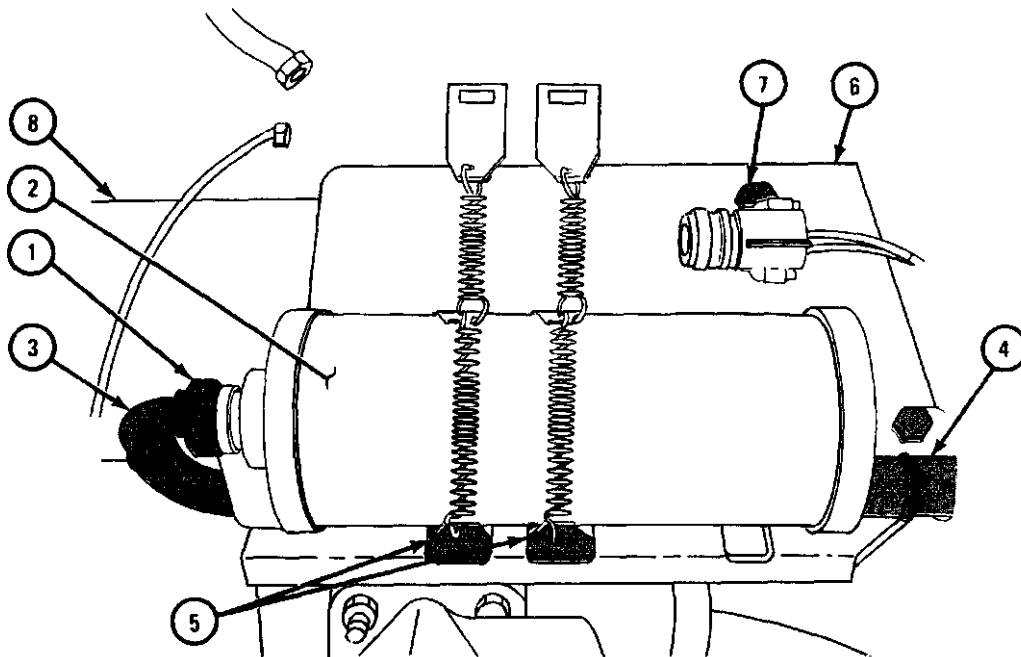

TA 051729

c. Replacement.

FRAME 1

1. Put support bracket assembly (1) on intake manifold (2).
2. Put wiring harness ground terminal (3) under capscrew and lockwasher (4) at front of support bracket assembly (1).
3. Using 1/2-inch wrench, screw in and tighten three capscrews and lockwashers (4).
4. Place ignition unit (5) on support bracket assembly (1) and hook up ignition unit clamp assembly (6).
5. Put ignition cable and conduit plug (7) in ignition unit (5) . Using 7/8-inch wrench, screw on and tighten nut (8) .
6. Screw wiring harness connector (9) on ignition unit (5) terminal.

GO TO FRAME 2

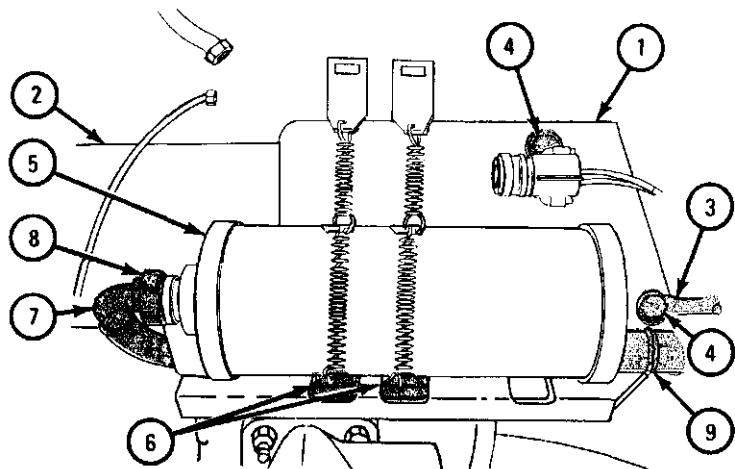
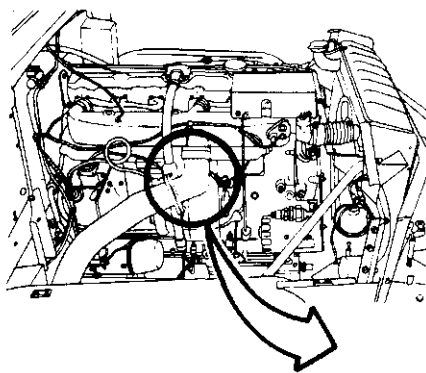

TA 051730

FRAME 2

CAUTION

Engine manifold flame heater fuel pump is negative grounded. "A" pin is positive and "B" pin is negative. Do not switch positions of pins or there could be permanent damage to pump.

1. Place fuel pump (1) on support bracket assembly (2). Hook fuel pump clamp assembly (3) to support bracket assembly (2).
2. Screw wiring harness connector (4) on fuel pump terminal (5).
3. Using 3/8-inch wrench, screw in and tighten inverted nut and tube (6).
4. Using 7/16-inch wrench, screw in and tighten inverted nut and tube (7).

GO TO FRAME 3

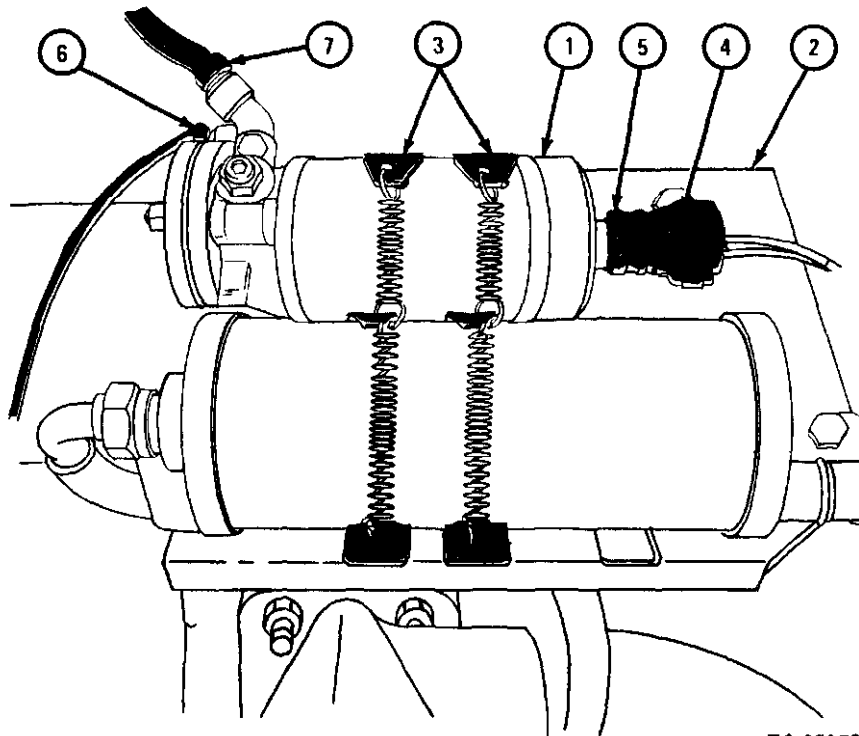

TA 051731

FRAME 3

1. Put cover (1) in place. Using 1/2-inch wrench, screw in and tighten four cap screws and lockwashers (2) .

NOTE

Follow-on Maintenance Action Required:

1. Reconnect battery ground. Refer to para 7-58.
2. Close hood. Refer to TM 9-2320-209-10.

END OF TASK

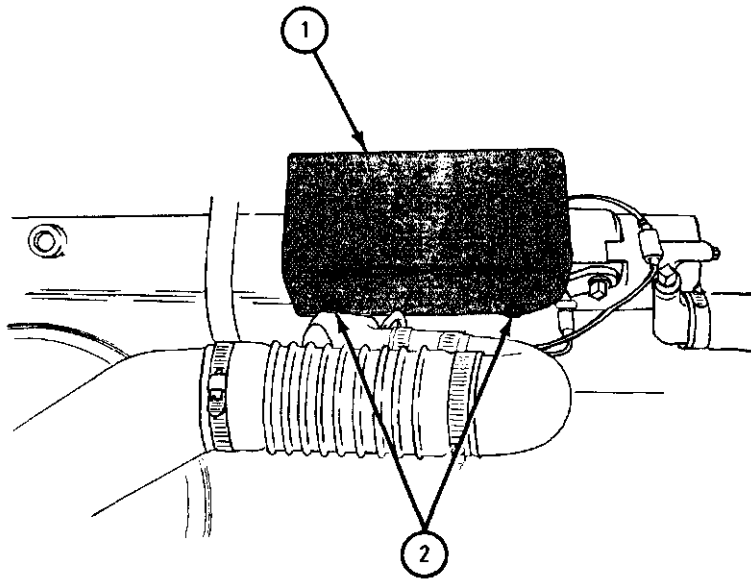

TA 051732

4-27. MANIFOLD HEATER (TOP-MOUNTED, COVERED) IGNITION COIL AND FUEL PUMP REMOVAL AND REPLACEMENT (TRUCKS WITH ENGINE LD 465-1C).

TOOLS :	1/2-inch wrench	3/8-inch wrench
	7/16-inch wrench	Flat-tip screwdriver
	7/8-inch wrench	6-inch slip joint pliers

SUPPLIES : None

PERSONNEL: One

EQUIPMENT CONDITION : Truck parked, engine off, handbrake set.

a. Preliminary Procedures.

(1) Open hood. Refer to TM 9-23270-209-10.

(2) Disconnect battery ground cable. Refer to para 7-58.

b. Removal.

FRAME 1

1. Using 1/2-inch wrench, unscrew and take out four capscrews (1) .
 2. Take off cover (2).
- GO TO FRAME 2

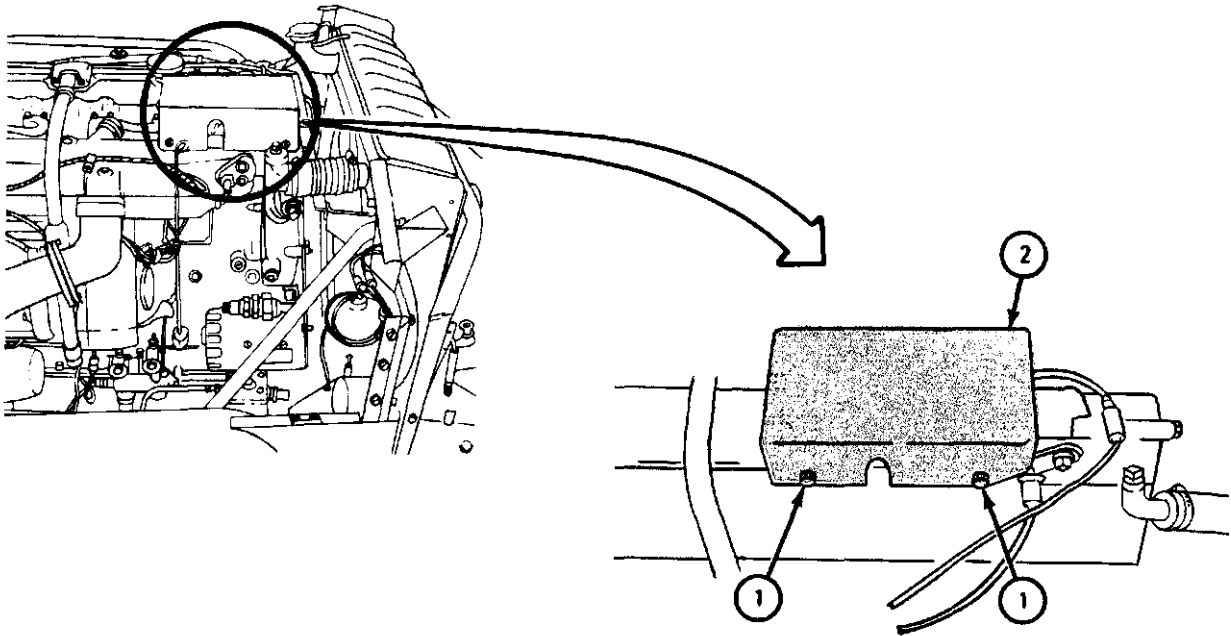

TA 083331

FRAME 2

1. Using 7/8-inch wrench, unscrew and take off electrical cable connector (1).
2. Using pliers, unscrew and take off electrical cable connector (2).
3. Using pliers, unscrew and take off electrical cable connector (3) from fuel pump (4).
4. Using 7/16-inch wrench, unscrew and take off tube fitting (5).
5. Using 3/8-inch wrench, unscrew and take off tube fitting (6).

GO TO FRAME 3

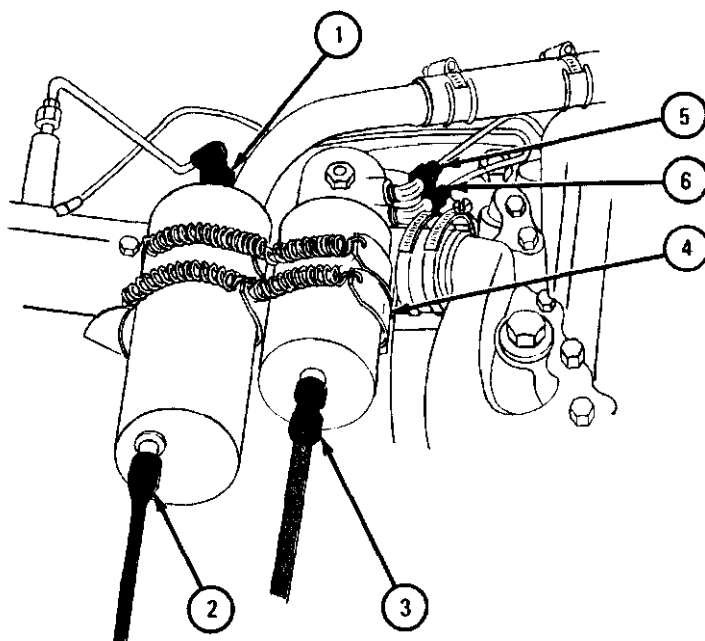

TA 083332

FRAME 3

1. Turn fuel pump (1) to left.
2. Using 7/16-inch wrench, unscrew and take off elbow (2) .
3. Using 3/8-inch wrench, unscrew and take off elbow (3).
4. Take off four clamps (4).
5. Take off ignition coil (5) and fuel pump (1) .

END OF TASK

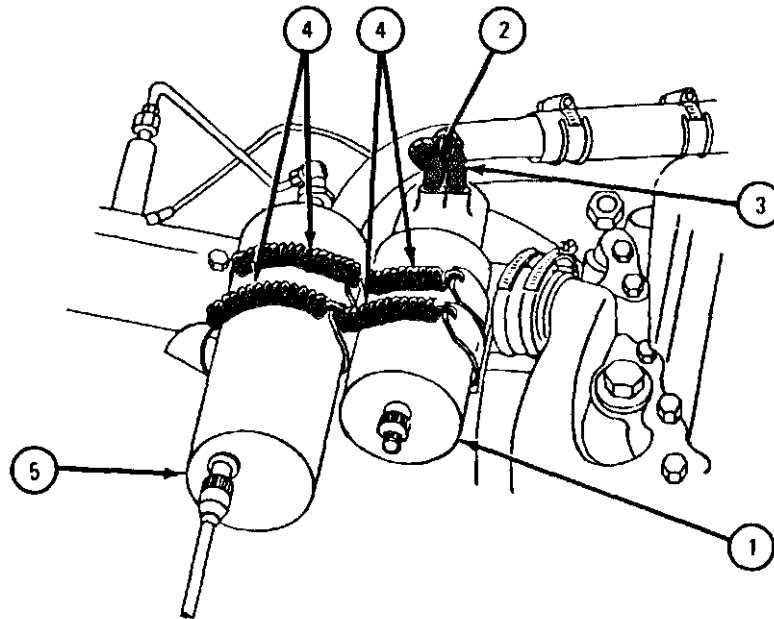

TA 085534

c. Replacement.

FRAME 1

1. Put ignition coil (1) and fuel pump (2) in place. Put on four clamps (3).
2. Using 3/8-inch wrench, screw on and tighten elbow (4).
3. Using 7/16-inch wrench, screw on and tighten elbow (5).
4. Turn fuel pump (2) to right.

GO TO FRAME 2

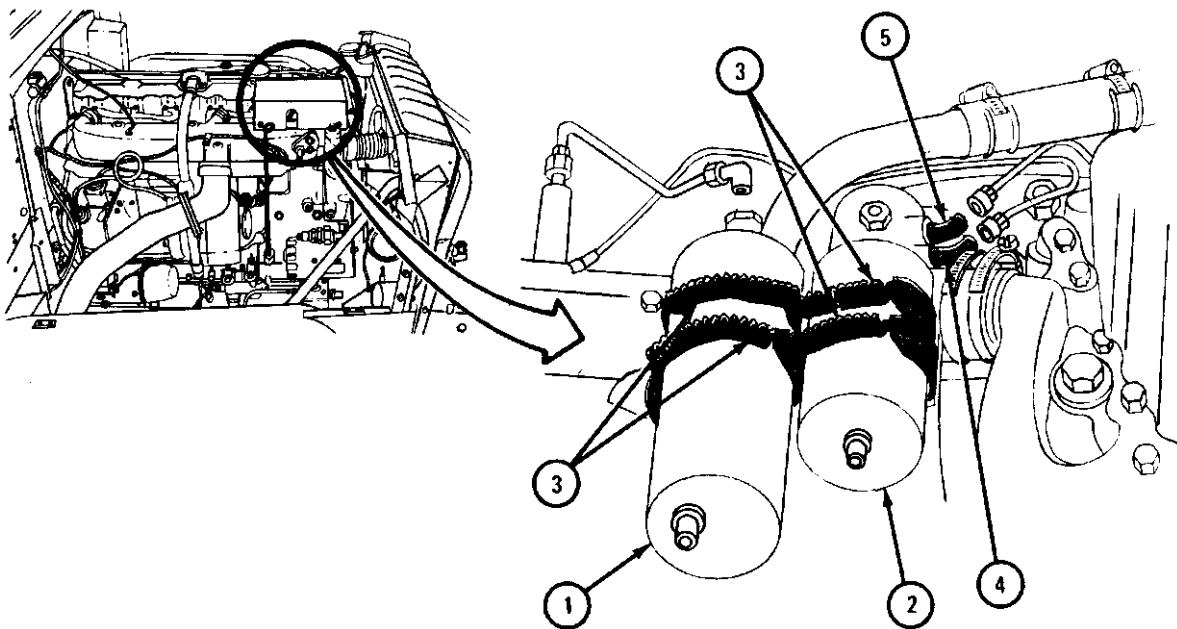

TA 085535

FRAME 2

1. Using 3/8-inch wrench, screw on and tighten tube fitting (1).
 2. Using 7/16-inch wrench, screw on and tighten tube fitting (2).
 3. Using pliers, screw on and tighten electrical cable connector (3) on fuel pump (4).
 4. Using pliers, screw on and tighten electrical cable connector (5).
 5. Using 7/8-inch wrench, screw on and tighten electrical cable connector (6).
- GO TO FRAME 3

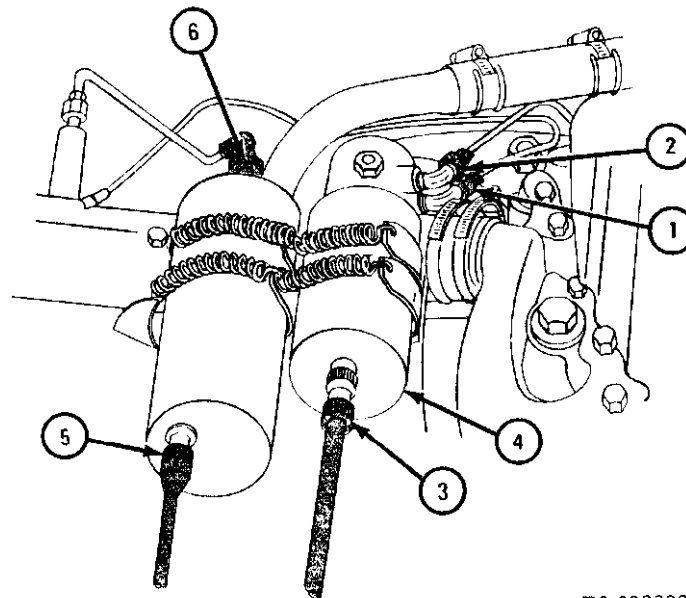

TA 083333

FRAME 3

1. Put cover (1) in place and align screw holes.
2. Using 1/2-inch wrench, screw on and tighten four capscrews (2).

NOTE

Follow-on Maintenance Action Required:

1. Reconnect battery ground cable. Refer to para 7-58.
2. Close hood. Refer to TM 9-2370-209-10.

END OF TASK

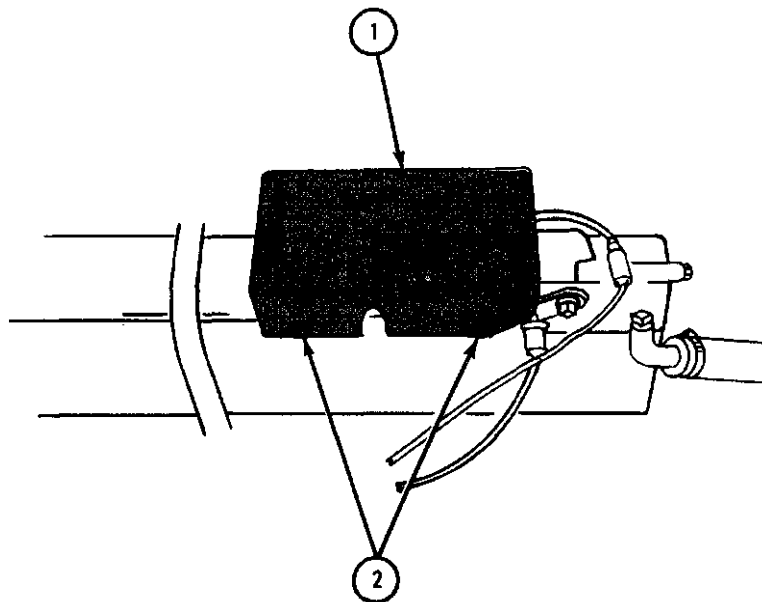

TA 083334

Section VI. ACCELERATOR, THROTTLE, AND ENGINE STOP CONTROLS

4-28. THROTTLE CONTROL AND LINKAGE REMOVAL, REPAIR, REPLACEMENT, AND ADJUSTMENT.

TOOLS : 9/16-inch open end wrench (2)
 Cross-tip screwdriver (Phillips type)
 6-inch scale

SUPPLIES: None

PERSONNEL: Two

EQUIPMENT CONDITION: Truck parked, engine off, handbrake set.

a. Preliminary Procedure. Open hood and right side panel. Refer to TM 9-2320-209-10.

b. Removal.

FRAME 1

1. Using screwdriver, loosen screw (1) and slide connector (2) off throttle control wire (3) .

GO TO FRAME 2

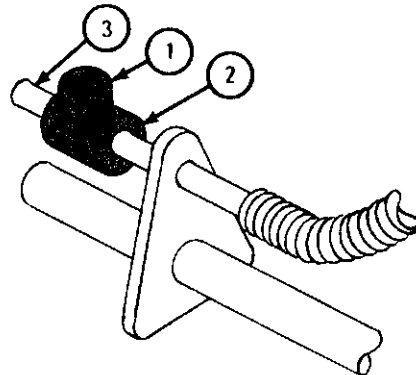
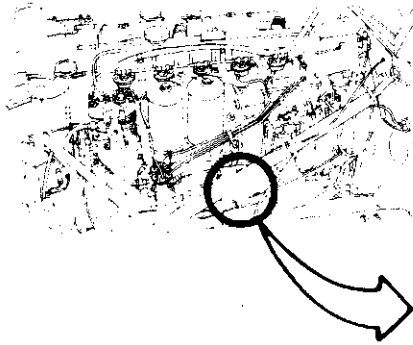

TA 047385

FRAME 2

- Soldier A 1. Using 9/16-inch wrench, hold floor fitting (1) and tell soldier B you are ready.
- Soldier B 2. Using 9/16-inch wrench, unscrew locknut (2) and slide locknut down and off end of throttle control cable (3).
- Soldier A 3. Pull throttle control cable (3) up through hole in floor and take floor fitting (1) off end of cable.

GO TO FRAME 3

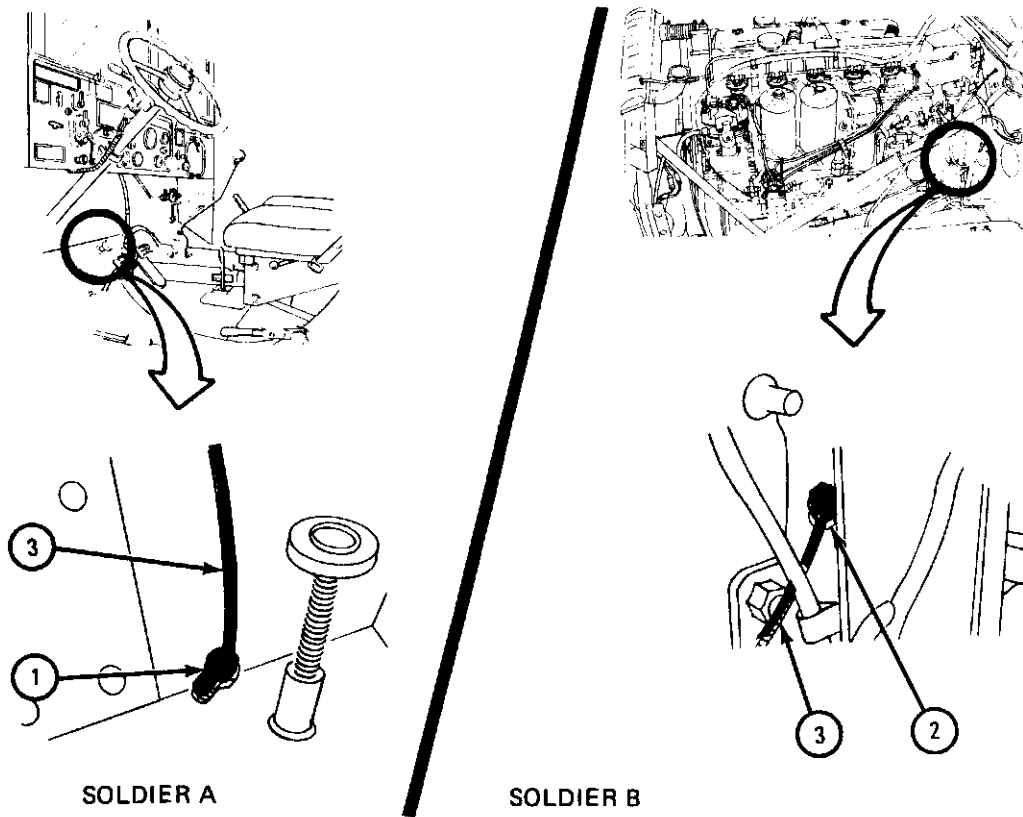

TA 047386

FRAME 3

1. Using 9/16-inch wrench behind instrument panel (1), unscrew nut (2). Slide nut and lockwasher (3) down off end of throttle control cable (4).
2. Pull throttle control cable assembly (5) out through hole from front of instrument panel (1).

END OF TASK

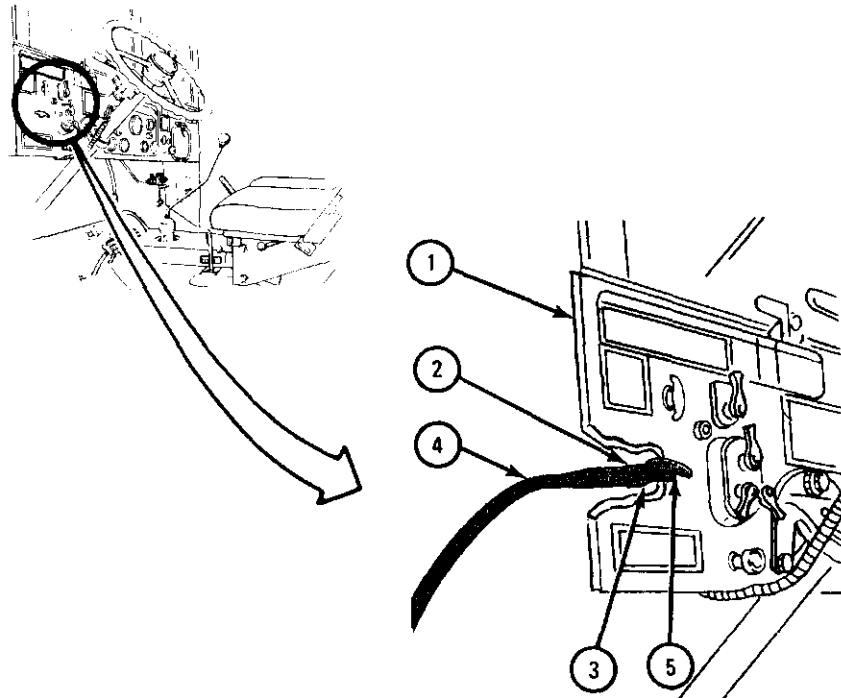

TA 047387

c. Repair. Repair throttle control and linkage by throwing away any bent, broken or worn parts. Use new parts in place of damaged ones.

d. Replacement.

FRAME 1

1. Put throttle control cable assembly (1) into hole from front of instrument panel (2) as shown.
2. Slide lockwasher (3), nut (4), and floor fitting (5) over end of control cable (6).
3. Slide lockwasher (3) and nut (4) up control cable (6) to back of instrument panel (2). Using 9/16-inch wrench, screw on and tighten nut.

GO TO FRAME 2

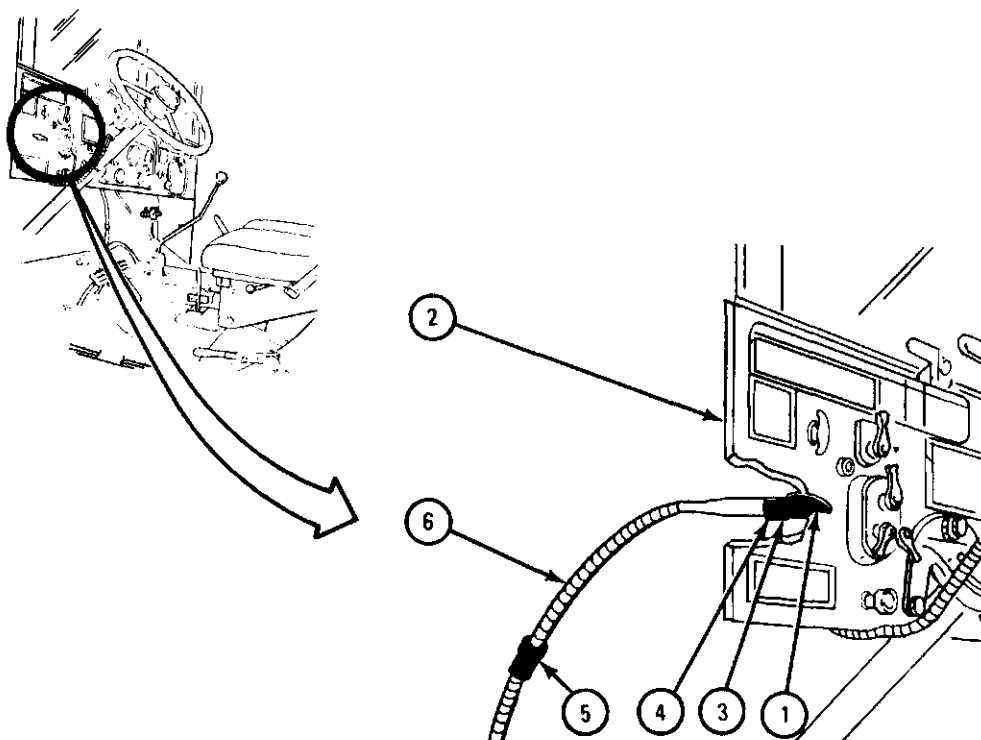

TA 047388

FRAME 2

Soldier A 1. Put throttle control cable (1) through hole in floor and slide floor fitting (2) down throttle control cable into hole.

Soldier B 2. Put locknut (3) on throttle control cable (1) and slide locknut up throttle control cable. Screw locknut onto floor fitting (2). Do not tighten locknut.

GO TO FRAME 3

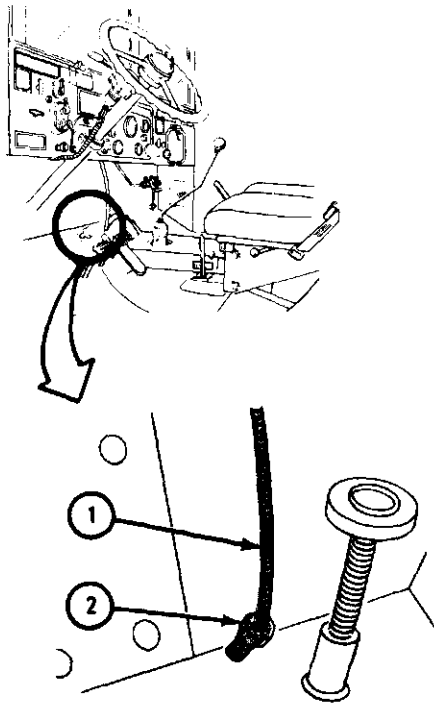

SOLDIER A

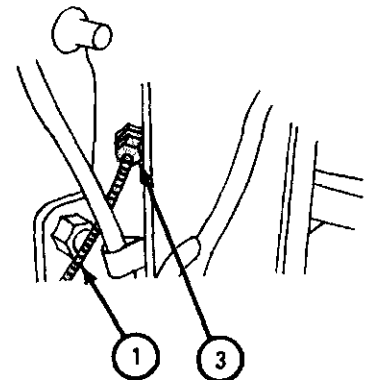
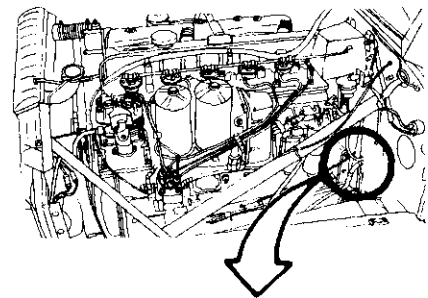

SOLDIER B

TA 047389

FRAME 3

1. Put control wire (1) through hole in clip (2).
2. Slide connector (3) over end of control wire (1) up to clip (2). Do not tighten screw (4) until adjustment procedure, para 4-28e, is done.

END OF TASK

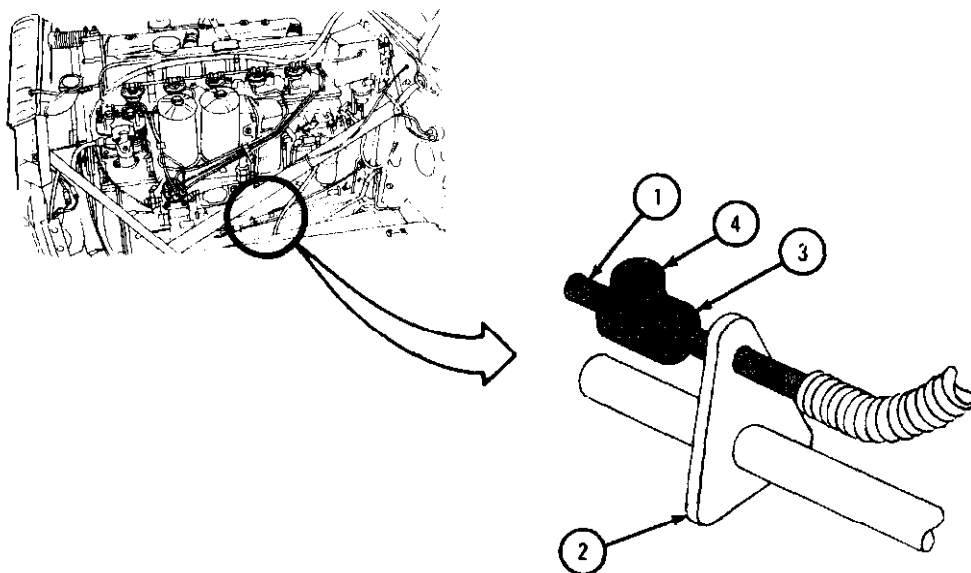

A 047390

e. Adjustment.

FRAME 1

- Soldier A 1. Push THROTTLE control (1) all the way in. Using foot, push and hold accelerator pedal (2) hard against stop.
- Soldier B 2. Check that accelerator rod (3) moves toward firewall as shown by arrow, and that it stays there. Using 6-inch scale, measure distance (4) between end of control cable housing (5) and clip (6).
3. Slide throttle control cable (7) through floor board until distance (4) is about 1/2 inch.
- Soldier A 4. Take foot off accelerator pedal (2).
- GO TO FRAME 2

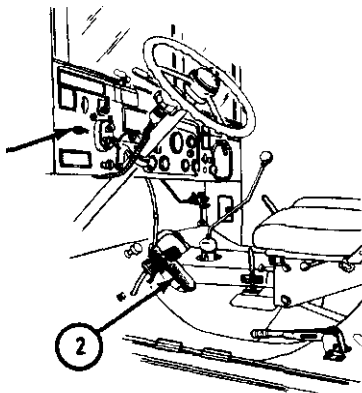

SOLDIER A

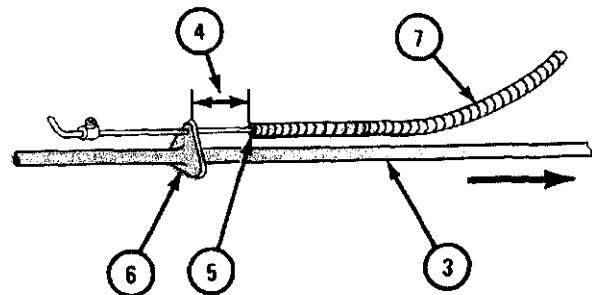
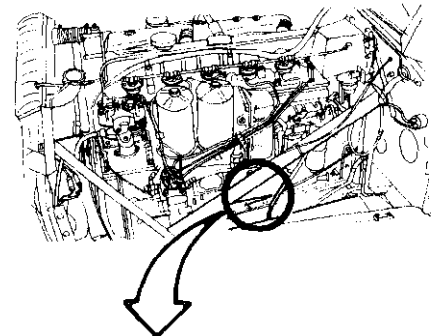

SOLDIER B

TA 047391

FRAME 2

Soldier A 1. Using 9/16-inch wrench, hold floor fitting (1) and tell soldier B you are ready.

Soldier B 2. Using 9/16-inch wrench, screw on and tighten locknut (2).

GO TO FRAME 3

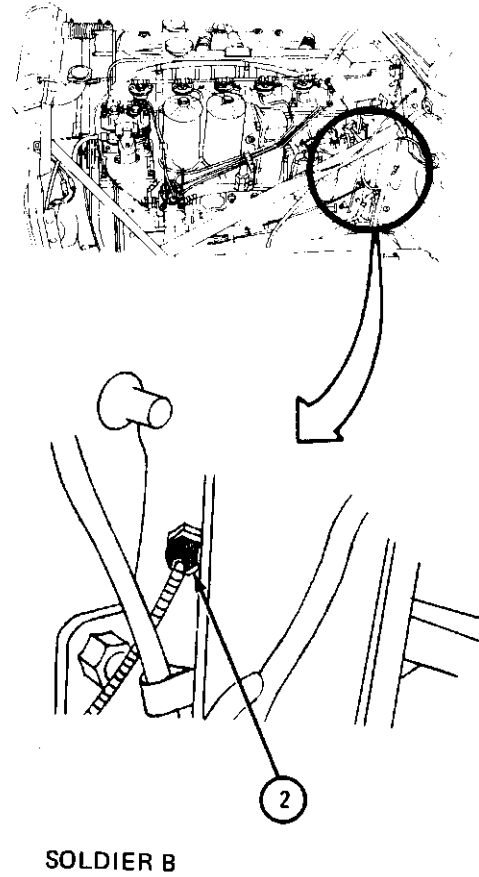
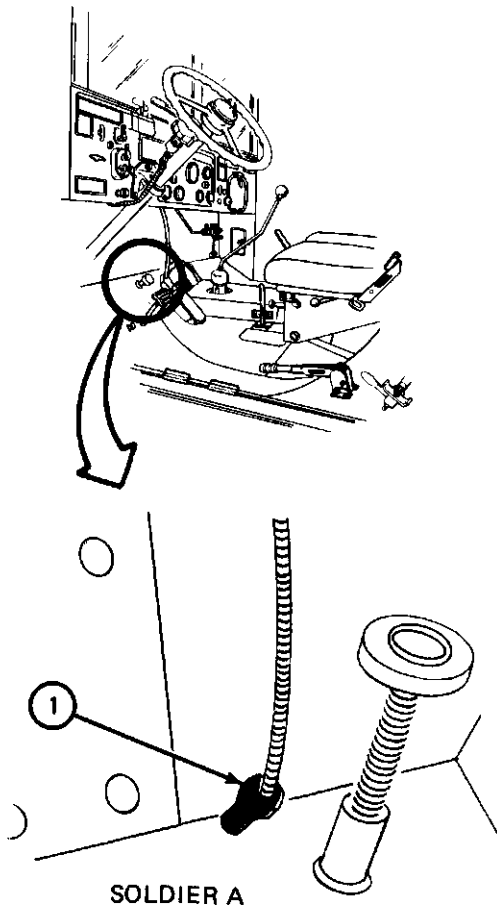

TA 080998

FRAME 3

- Soldier B 1. Slide connector (1) along control wire (2) until it is flush against clip (3).
2. Using screwdriver, tighten screw (4).
- Soldier A 3. Push and release accelerator pedal (5) three or four times.
- Soldier B 4. Check that clip (3) slides back and forth freely on control wire (2).
- Soldier A 5. Pull out and push in THROTTLE control (6) three or four times.
- Soldier B 6. Check that accelerator rod (7) moves back and forth freely.

NOTE

Follow-on Maintenance Action Required:

Close hood and right side panel. Refer to TM 9-2320-209-10.

END OF TASK

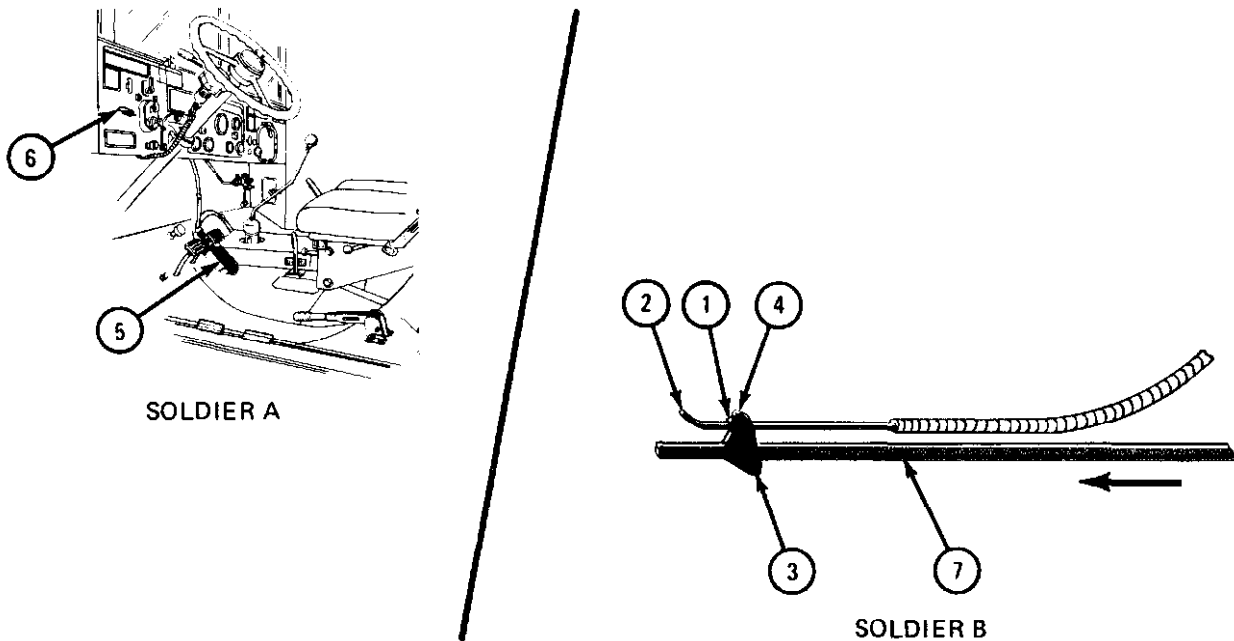

TA 047392

4-29. ACCELERATOR CONTROLS AND LINKAGES REMOVAL, REPAIR, REPLACEMENT, AND ADJUSTMENT.

TOOLS : 1/2-inch open end wrench
1/2-inch socket wrench
Cross-tip screwdriver (Phillips type)
Long nose pliers
Diagonal pliers

SUPPLIES : None

PERSONNEL : Two

EQUIPMENT CONDITION : Truck parked, engine off, handbrake set.

a. Preliminary Procedure. Open hood and left side panel. Refer to TM 9-2320-209-10.

b. Removal.

FRAME 1

1. Take ends of throttle return spring (1) out of swivel assembly (2) and throttle return clip (3).
2. Using phillips screwdriver, loosen screw (4) and slide coupling (5) off hand throttle control wire (6). Pull wire out of clip (7).
3. Using pliers, take cotter pin (8) out of straight-headed pin (9). Pull out straight-headed pin.

GO TO FRAME 2

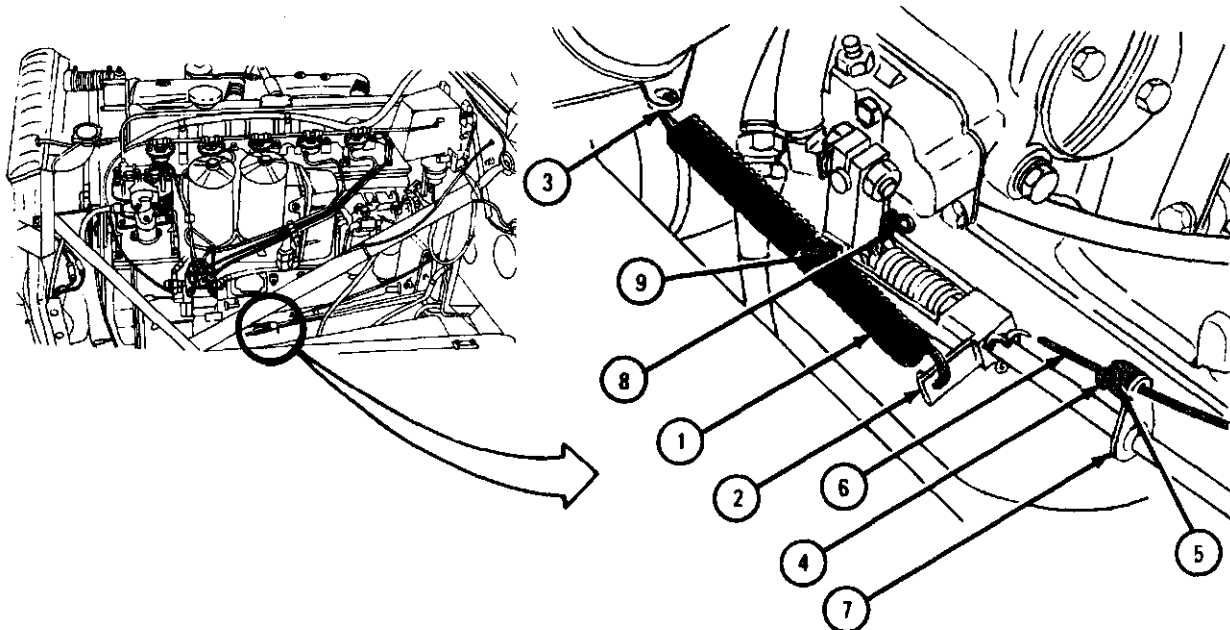

TA 047144

FRAME 2

1. Working from under truck and using 1/2-inch wrench, unscrew locknut (1) from ball joint (2) . Take out accelerator linkage assembly (3) .
 2. Using pliers, take out cotter pin (4) and two cotter pins (5). Throw cotter pins away.
 3. Pull headless pin (6) out of lever assembly (7) and take out lever assembly.
- GO TO FRAME 3

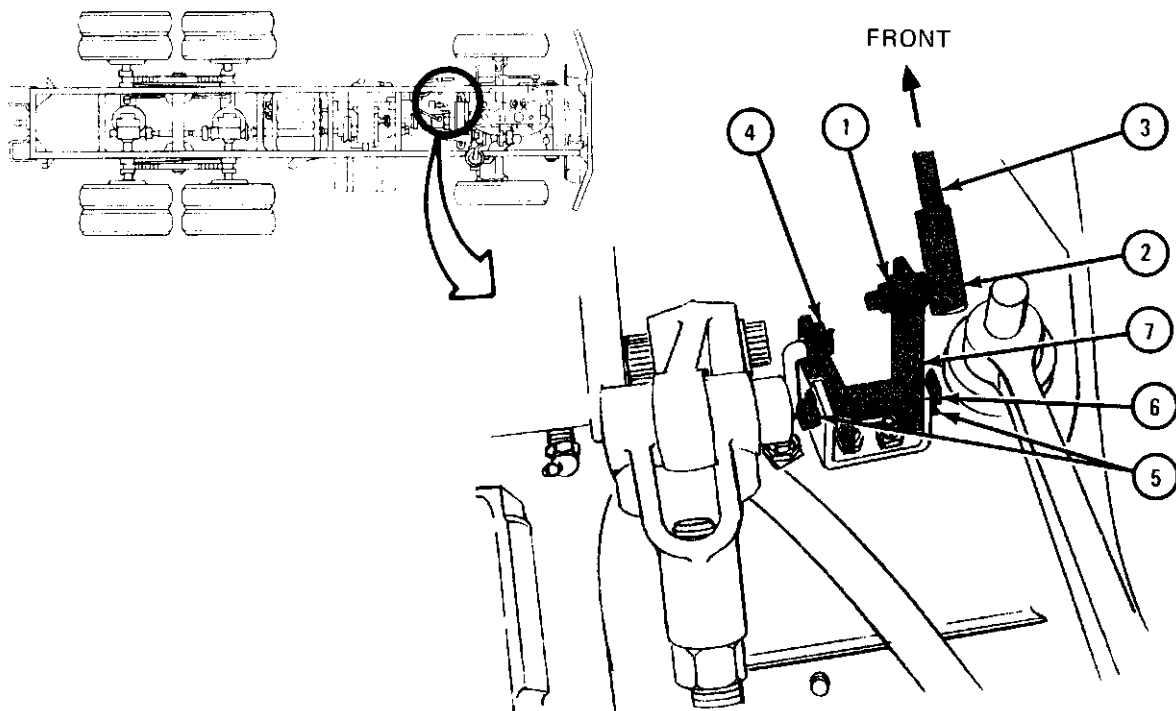

TA 047145

FRAME 3

- Soldier A
1. Using pliers, take cotter pin (1) out connecting link (2).
 2. Pull straight pin (3) out of pedal bracket (4) and take connecting link (2) out of control pedal (5). Set control pedal and connecting link aside.
 3. Using 1/2-inch wrench, hold each of two bolts (6). Tell soldier B that you are ready.
- Soldier B
4. Using 1/2-inch socket wrench, unscrew and take off two locknuts (7). Take off control bracket (8).

END OF TASK

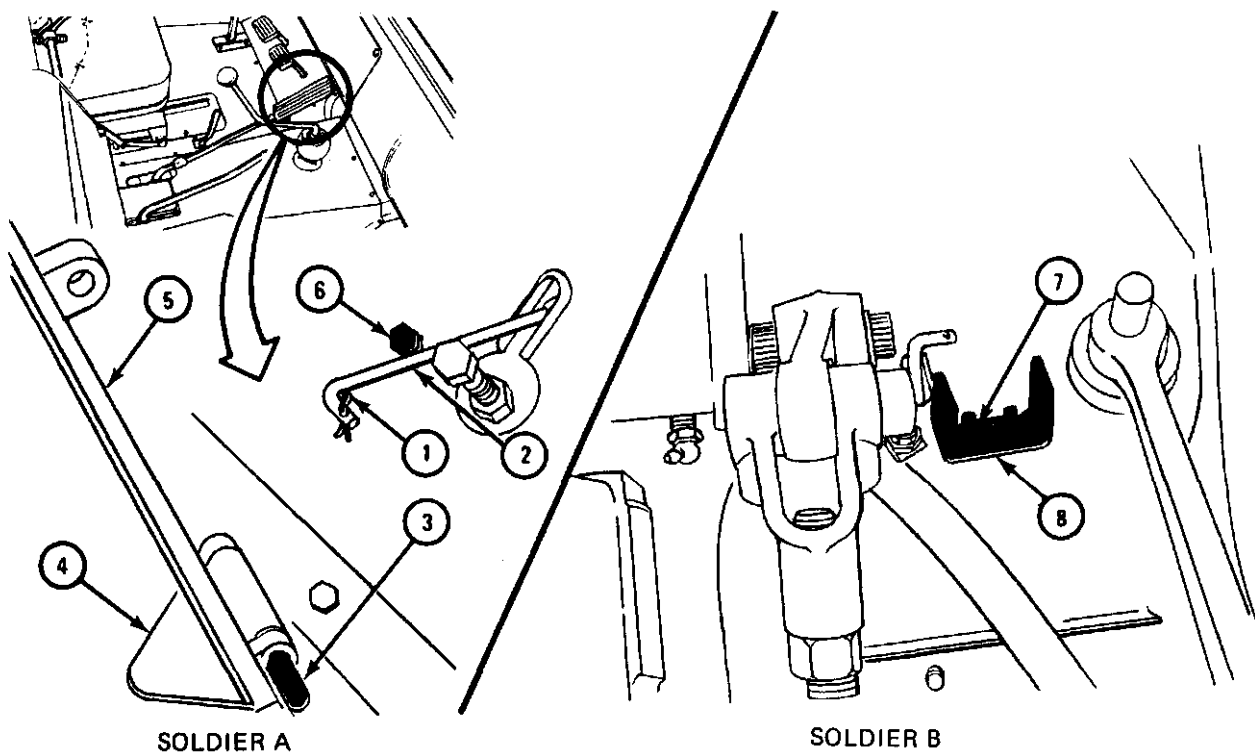

TA 047146

c. Repair. Repair accelerator controls and linkages by replacing damaged or unserviceable parts.

d. Replacement.

FRAME 1

- Soldier A 1. Put two bolts (1) through floor and hold bolts down with fingers.
- Soldier B 2. Working under truck, put control bracket (2) on two bolts (1) and screw on two locknuts (3).
- Soldier A 3. Using wrench, hold each of two bolts (1) in turn.
- Soldier B 4. Using socket wrench, tighten locknuts (3).
- Soldier A 5. Put connecting link (4) through slot in floor as shown.
6. Put control pedal (5) in pedal bracket (6) as shown. Put straight pin (7) through pedal bracket and control pedal.
7. Put end of connecting link (4) through hole at top of control pedal. Put cotter pin (8) through connecting link. Using pliers, spread cotter pin.

GO TO FRAME 2

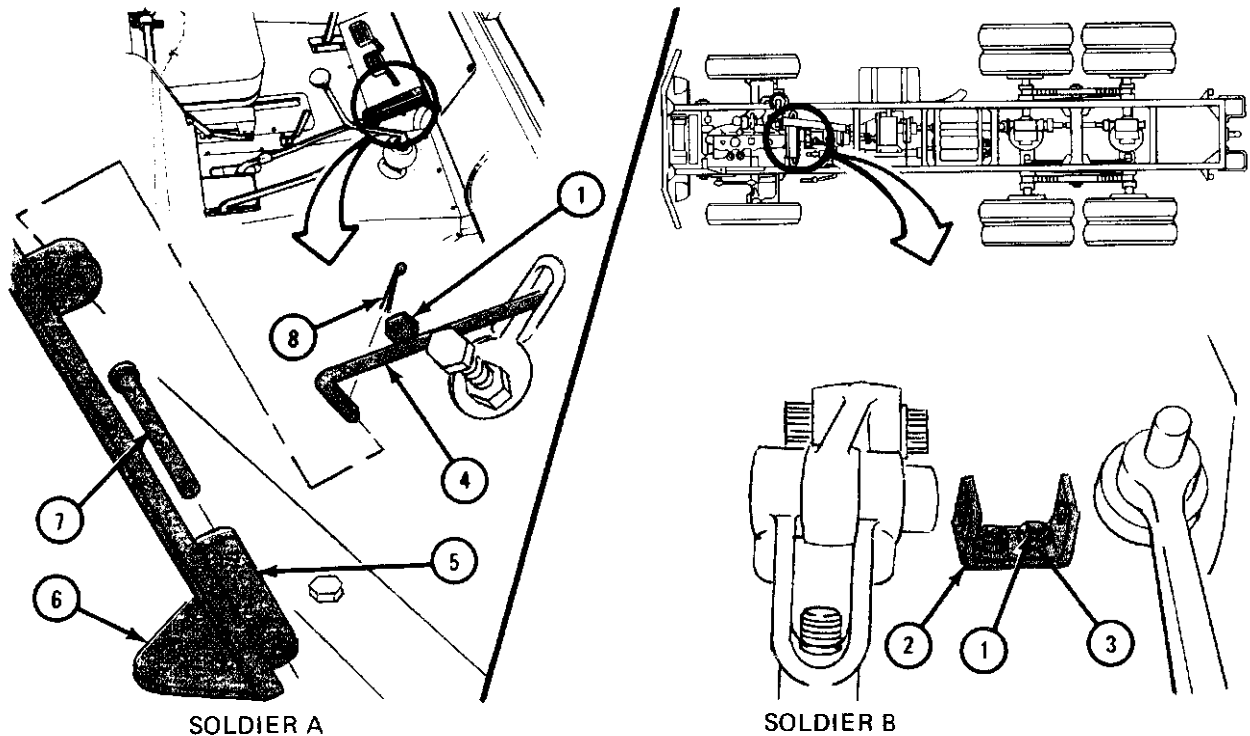

TA 047147

FRAME 2

1. Put end of connecting link (1) through hole in lever assembly (2) as shown. Put cotter pin (3) through hole in end of connecting link. Using pliers, spread cotter pin.
2. Place lever assembly (2) in bracket (4) as shown. Put headless pin (5) through holes in bracket and lever assembly.
3. Put two cotter pins (6) through holes in headless pin (5). Using pliers spread cotter pins .
4. Put stud of ball joint (7) through hole in lever assembly (2) as shown. Using 1/2-inch wrenches, screw on and tighten locknut (8).

GO TO FRAME 3

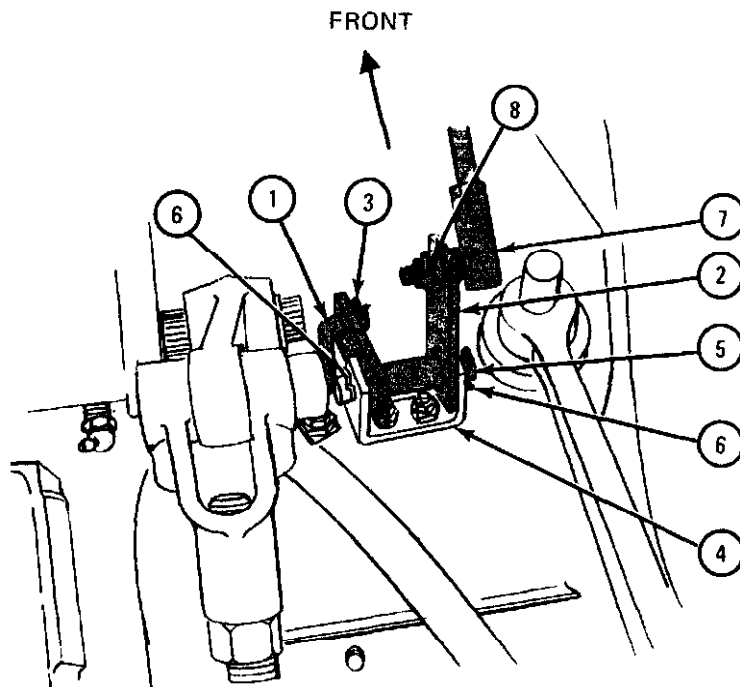

TA 047148

FRAME 3

1. Using left hand, push rack lever (1) toward rear of truck as shown by arrow. Push lever as far as it will go and hold it.
2. Using right hand, move control rod (2) to rear as shown by arrow. Move control rod as far as it will go (pedal in cab hits against stop) and hold it.
3. Aline hole in rack lever (1) with holes in swivel assembly (3). It should be necessary to move swivel assembly forward on control rod (2) , squeezing spring (4) about 1/4 inch.
4. If spring (4) does not squeeze slightly, control rod (2) must be made shorter. If spring squeezes too much, control rod (2) must be made longer. To set length of control rod, refer to adjustment procedure, para 4-29e.

GO TO FRAME 4

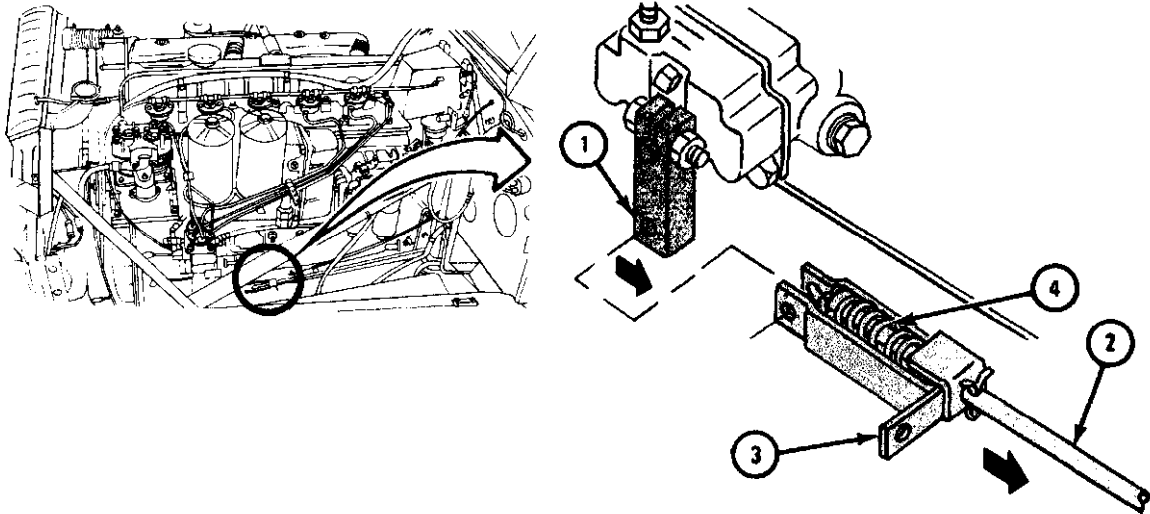

TA 047149

FRAME 4

1. Aline holes in swivel assembly (1) with hole in rack lever (2). Put pin (3) through swivel assembly and rack lever.
2. Put cotter pin (4) through hole in pin (3). Using pliers, spread cotter pin,
3. Hook one end of throttle return spring (5) to throttle return clip (6). Hook other end of spring to swivel assembly (1).

Go TO FRAME 5

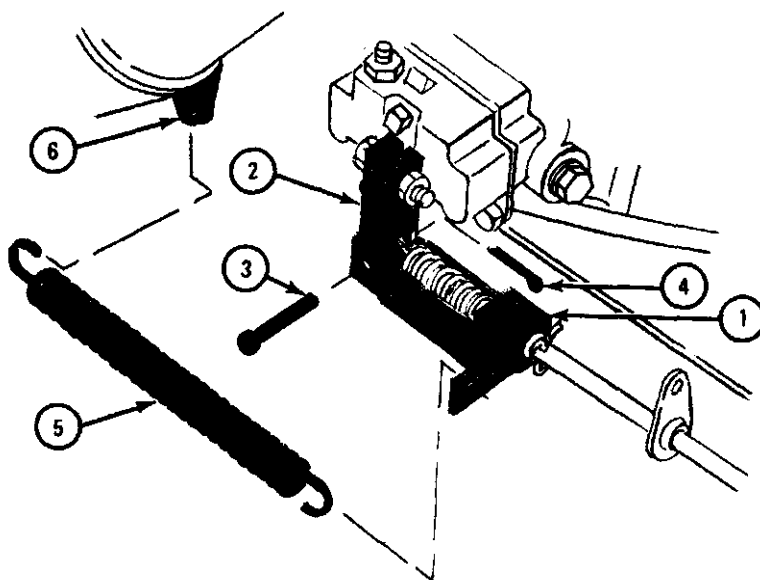

TA 047150

FRAME 5

1. Put hand throttle control wire (1) through clip (2). Slide coupling (3) on end of throttle control wire and up to clip.
2. Place coupling (3) 1/8 inch away from clip (2) and tighten screw (4) using phillips screwdriver.
3. Move control rod (5) forward and to rear several times to check operation of control linkages. Make sure linkages move freely.

NOTE

Follow-on Maintenance Action Required:

Close hood and left side panel. Refer to TM 9-2320-209-10.

END OF TASK

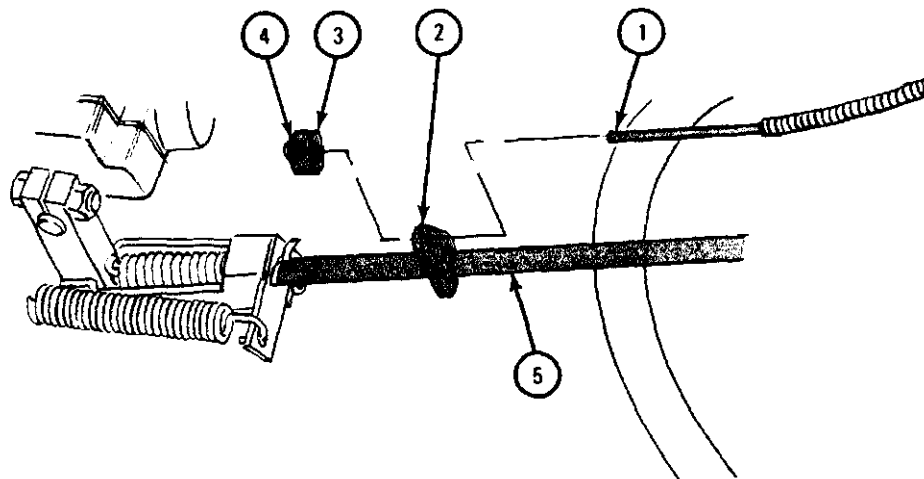

TA 047151

e. Adjustment.

FRAME 1

1. Using 1/2-inch wrench, unscrew and take off locknut (1) from threaded stud on ball joint (2).
2. Take ball joint (2) out of lever assembly (3).
3. Using 1/2-inch wrench, loosen nut (4).
4. Shorten rod (5) by screwing ball joint (2) onto rod.
5. Lengthen rod (5) by unscrewing ball joint (2).
6. When length of rod (5) is correct, threaded stud on ball joint (2) will slide into lever assembly (3) freely. Put threaded stud of ball joint (2) through hole in lever assembly (3) and using 1/2-inch wrench, tighten nut (4).
7. Using 1/2-inch wrench, screw locknut (1) on threaded stud of ball joint (2).

END OF TASK

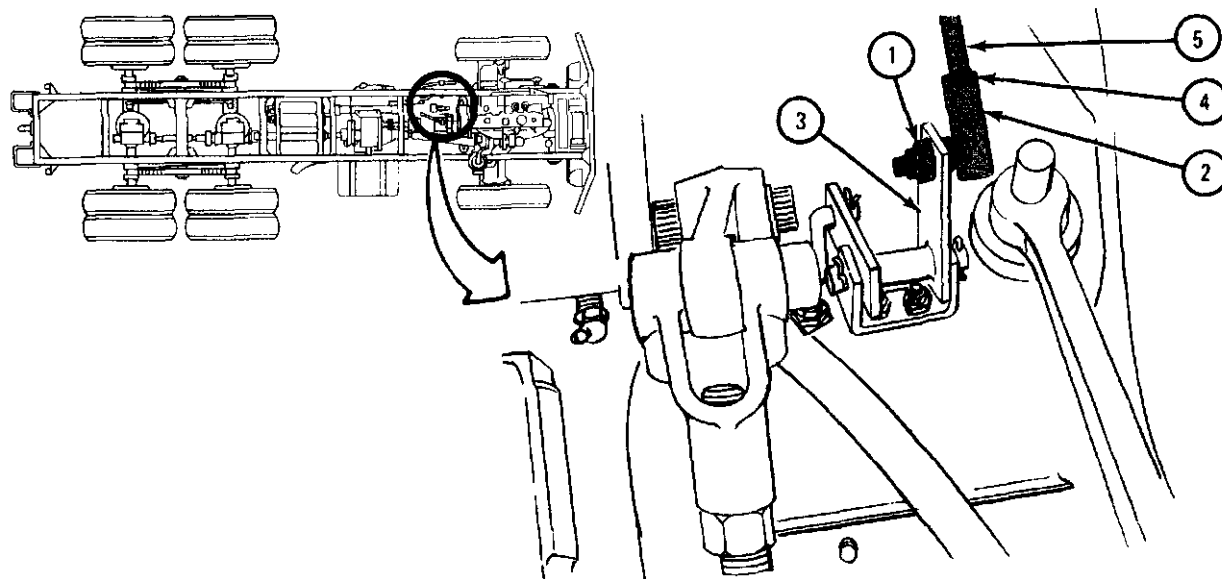

TA 047152

4-30. ENGINE STOP CONTROLS AND LINKAGES REMOVAL, REPAIR, REPLACEMENT, AND ADJUSTMENT.

TOOLS : 9/16-inch wrench
 11/32-inch wrench
 Cross-tip screwdriver (Phillips type)

SUPPLIES: None

PERSONNEL: One

EQUIPMENT CONDITION: Truck parked, engine off, handbrake set.

a. Preliminary Procedures.

(1) Open hood and left side panel. Refer to TM 9-2320-209-10.

(2) Remove light switch. Refer to para 7-14.

Removal.

FRAME 1

1. Using 11/32-inch wrench and screwdriver, unscrew and takeoff nut (1). Take screw (2) out of clamp (3), and take off two lockwashers (4).
2. Take clamp (3) off control cable (5).
3. Using screwdriver, loosen screw (6). Straighten end of control cable wire (7) and pull it out of swivel (8).
4. Take clip (9) off steering column.

GO TO FRAME 2

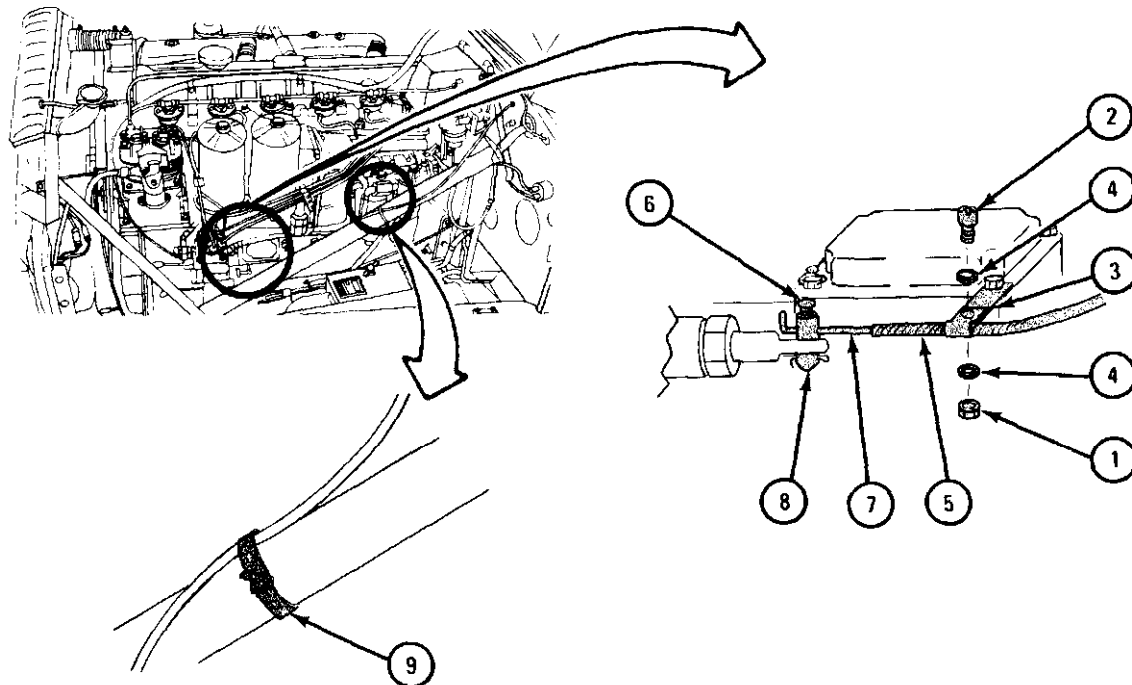

TA 047396

FRAME 2

1. Using 9/16-inch wrench, unscrew nut (1) behind instrument panel (2). Slide nut and lockwasher (3) back on control cable (4).
2. Pull control assembly (5) out from front of instrument panel (2). Take nut (1) and lockwasher (3) off end of control cable (4) after it comes through hole in firewall (6).
3. Take grommet (7) out of hole in firewall (6).

END OF TASK

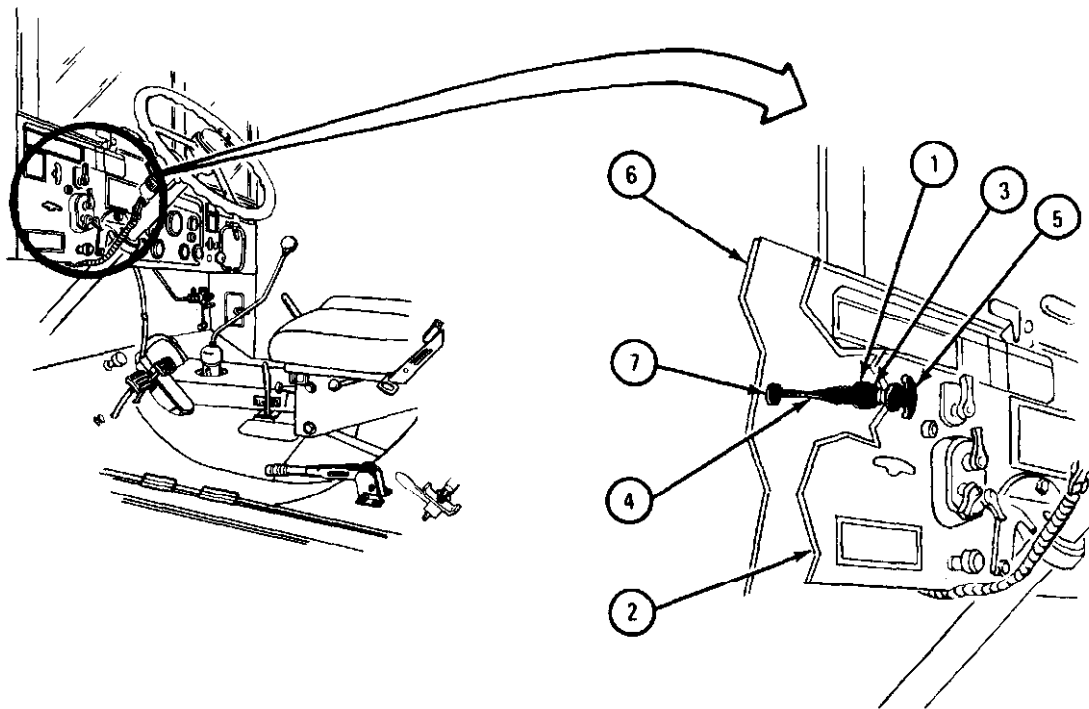

TA 047397

- c. Repair. Repair engine stop control and linkage by replacing damaged or worn parts.
- d. Replacement.

FRAME 1

1. Put grommet (1) in hole in firewall (2).
 2. Put end of control cable (3) through hole in instrument panel (4).
 3. Put lockwasher (5) and nut (6) on end of control cable (3) and slide them up control cable to back of instrument panel (4).
 4. Put end of control cable (3) through grommet (1) and push control assembly (7) into place as shown.
 5. Using 9/16-inch wrench, screw on and tighten nut (6) with lockwasher (5) .
- GO TO FRAME 2

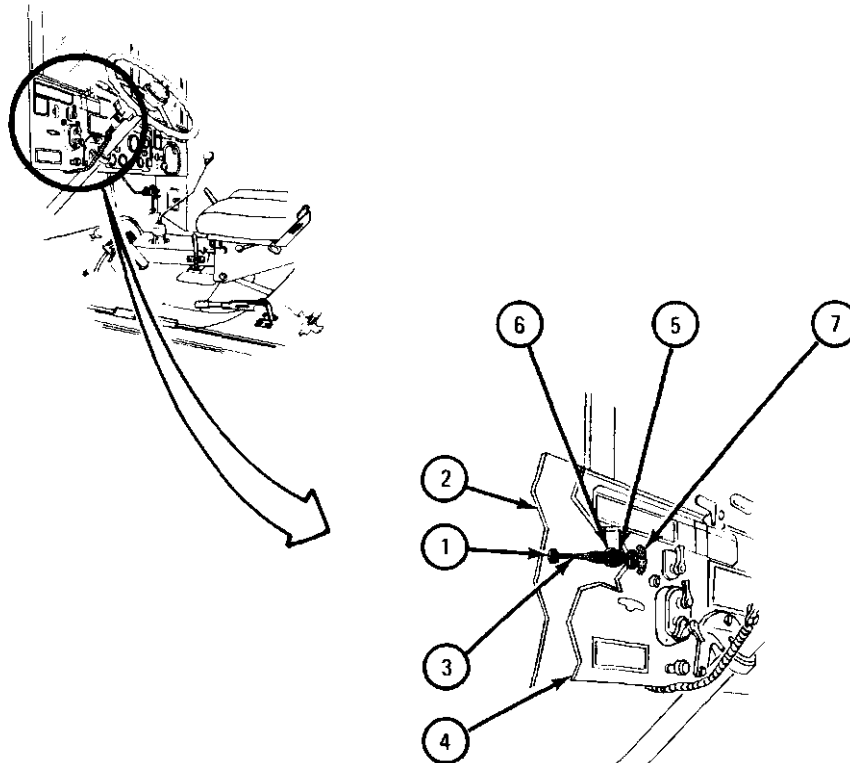

TA 047398

FRAME 2

1. Put clamp (1) on control cable (2) and injector pump flange as shown. Put in screw (3), two lockwashers (4), and nut (5) as shown. Do not tighten nut at this time.
2. Slide control cable (2) in clamp (1) to put control wire (6) through hole in swivel (7). Do not tighten screw (8) at this time.
3. Snap clip (9) around control cable (2) and steering column (10).

END OF TASK

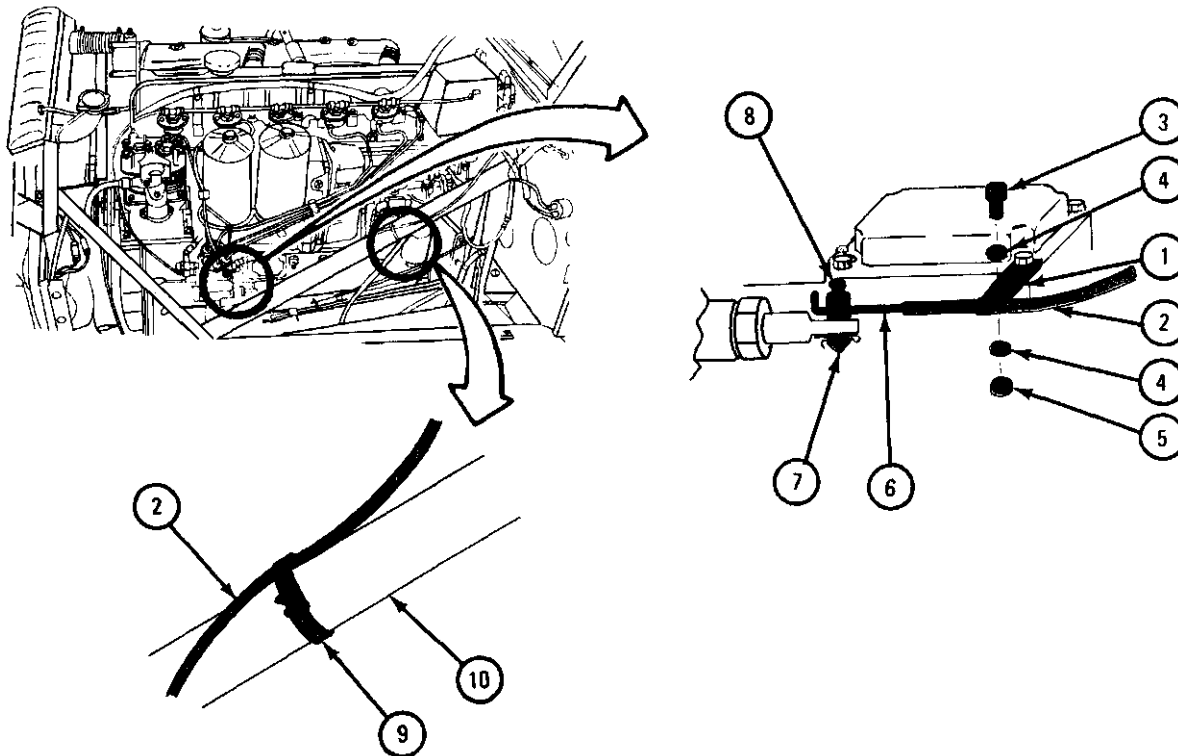

TA 047399

e. Adjustment.

FRAME 1

1. Push ENGINE STOP control (1) all the way in.
2. Pull fuel shutoff valve actuator (2) all the way out (toward firewall).
3. Slide control cable (3) in clamp (4) so that end of control cable clears fuel shutoff valve actuator (2) by no less than 1/2-inch.
4. Using 11/32-inch wrench and screwdriver, tighten nut (5) on screw (6). Push fuel shutoff valve actuator (2) all the way in.
5. Make sure control wire (7) passes through hole in swivel (8) as shown. Using screwdriver, tighten screw (9). Bend end of control wire up.
6. Move ENGINE STOP control (1) out and in several times.
7. Check that fuel shutoff valve actuator (2) and control linkage move smoothly without binding.

NOTE

Follow-on Maintenance Action Required:

1. Close hood and left side panel. Refer to TM 9-2320-209-10.
2. Replace light switch. Refer to para 7-14.

END OF TASK

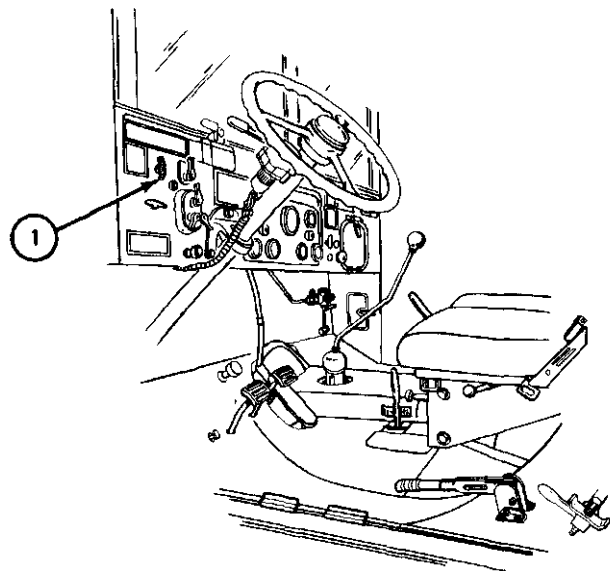
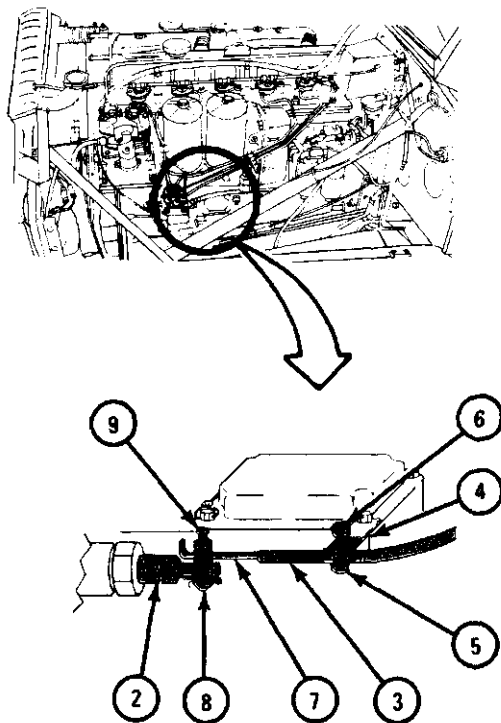

TA 047404

CHAPTER 5

EXHAUST SYSTEM GROUP MAINTENANCE

Section I. SCOPE

5-1. EQUIPMENT ITEMS COVERED . This chapter gives equipment maintenance procedures for exhaust pipes and mufflers for which there are authorized corrective maintenance tasks at the organizational maintenance level.

5-2. EQUIPMENT ITEMS NOT COVERED. All equipment items for which corrective maintenance is authorized at the organizational maintenance level are covered in this chapter.

Section II. EXHAUST PIPES AND MUFFLERS

5-3. EXHAUST SYSTEM (HORIZONTAL) REMOVAL AND REPLACEMENT (TRUCKS WITH ENGINE LD 465).

TOOLS : 9/16-inch wrench (2)
Hammer, medium
1/2-inch chisel

SUPPLIES : Tailpipe extension gasket
Front exhaust pipe gasket
Manifold elbow gasket

PERSONNEL: Two

EQUIPMENT CONDITION : Truck parked, engine off and cool, handbrake set.

a. Preliminary Procedure. Remove air cleaner. Refer to para 4-3.

WARNING

Do not work on hot exhaust systems.
Personnel can be badly burned.

b. Removal.

FRAME 1

1. Using 9/16-inch wrenches, unscrew and take off three locknuts (1) and capscrews (2).
 2. Take off tailpipe extension pipe (3) and gasket (4). Throw away gasket.
- GO TO FRAME 2

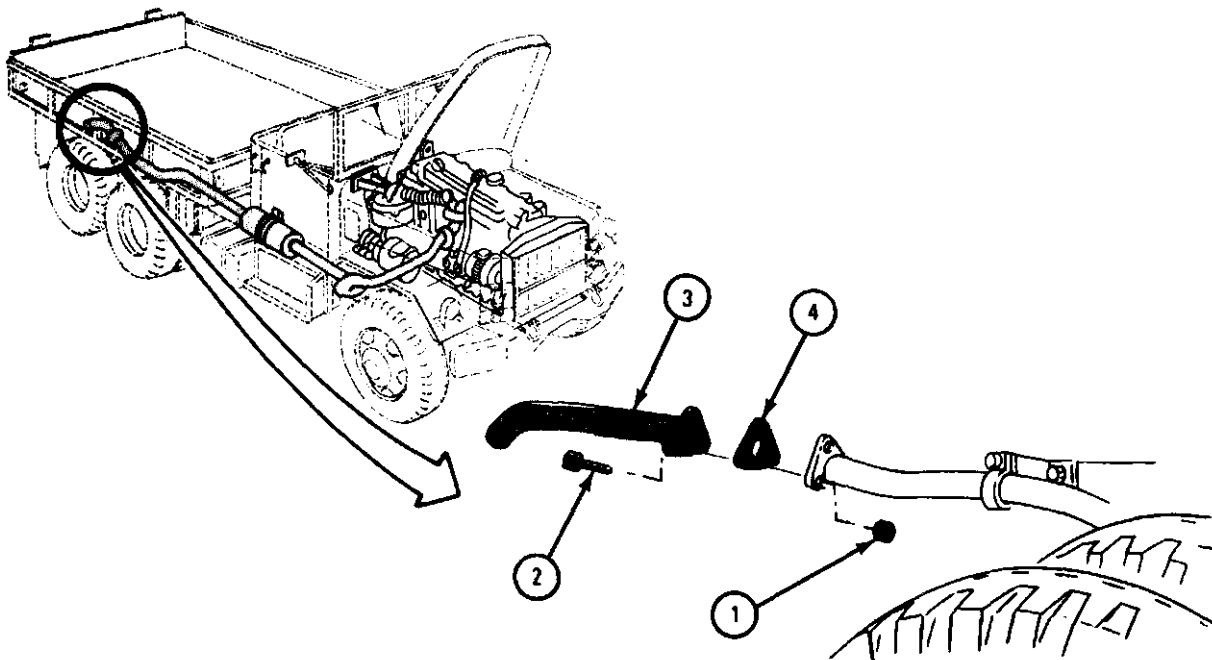

TA 080725

FRAME 2

1. Using 9/16-inch wrench , unscrew and take off two nuts (1) , washers (2) , and clamp bracket (3) . Take off U-bolt (4).
2. Using 9/16-inch wrenches, unscrew and take off capscrew (5) and locknut (6) from tailpipe bracket (7) .

GO TO FRAME 3

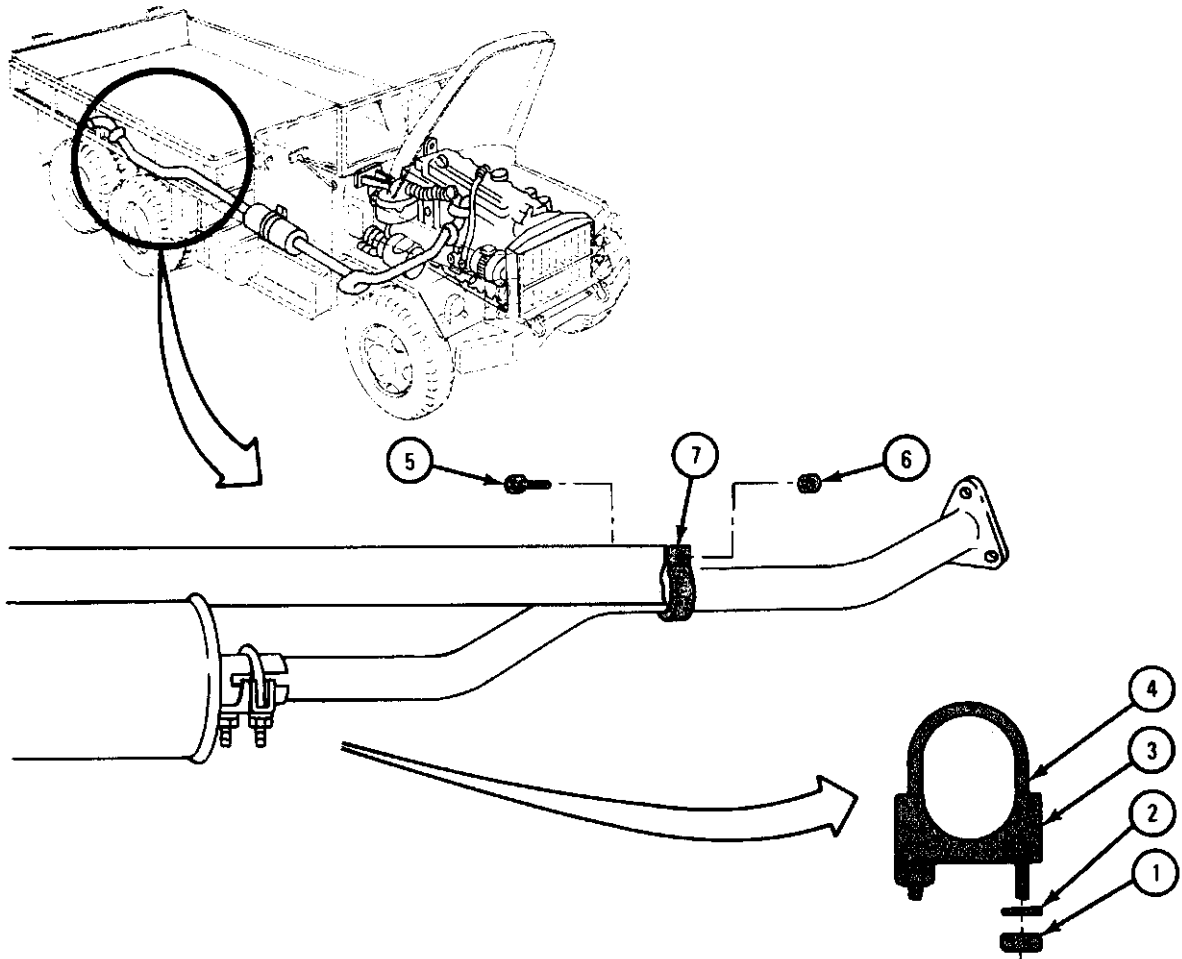

TA 080726

FRAME 3

Soldier A 1. Hold muffler (1).

NOTE

Tailpipe (2) may be stuck to muffler (1) . If needed, use hammer and chisel to loosen tailpipe.

Soldier B 2. Take out tailpipe (2) from muffler (1) by turning tailpipe back and forth and pulling it out.

3. Spread open and take off loop clamp (3) .

GO TO FRAME 4

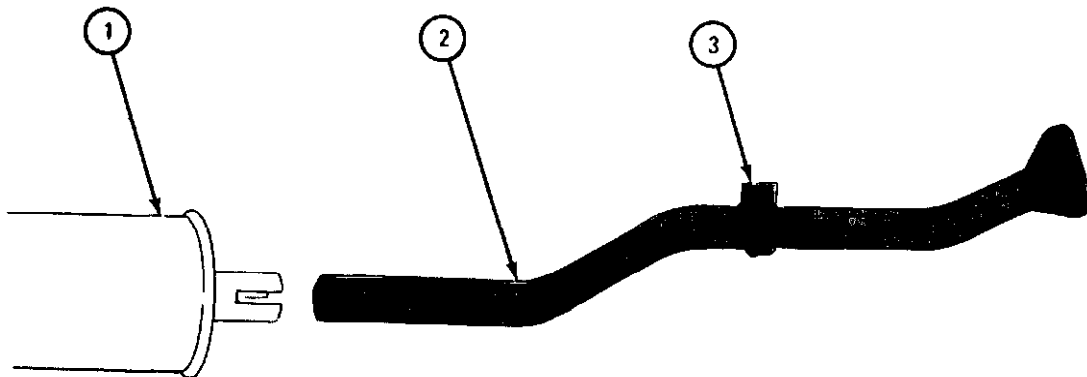

TA 080703

FRAME 4

- Soldier A 1. Using 9/16-inch wrench, unscrew and take off two nuts (1), washers (2), and clamp bracket (3). Take off U-bolt (4).
- Soldier B 2. Hold muffler (5) so it does not fall.
- Soldier A 3. Using 9/16-inch wrenches, unscrew and take off two nuts (6) and capscrews (7) from muffler loop clamp (8).

GO TO FRAME 5

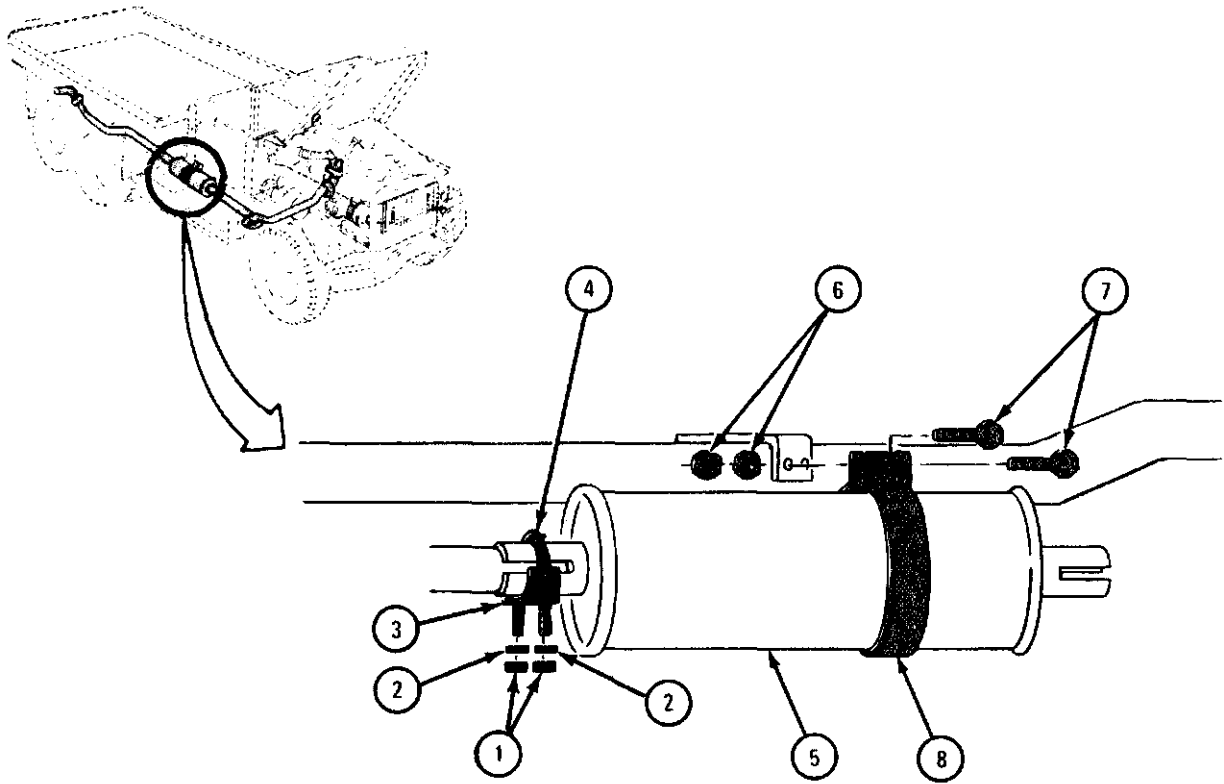

TA 080727

FRAME 5

Soldier A 1. Hold exhaust pipe (1).

NOTE

Muffler (2) may be stuck to front exhaust pipe (1). If needed, use hammer and chisel to loosen muffler.

Soldier B 2. Take off muffler (2) by turning it back and forth and pulling it off.

3. Spread open and take off muffler loop clamp (3).

GO TO FRAME 6

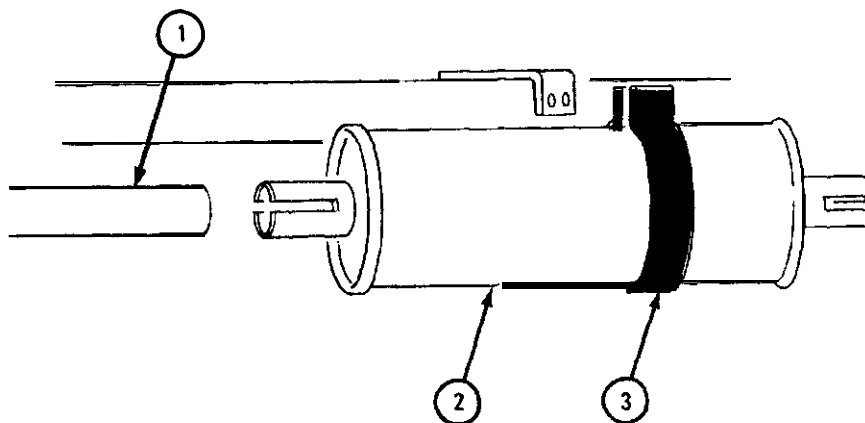

TA 080728

FRAME 6

1. Using 9/16-inch wrench, unscrew and take out capscrew (1).
2. Pull pebble shield (2) away from front exhaust pipe (3) so that pipe can be taken out.

GO TO FRAME 7

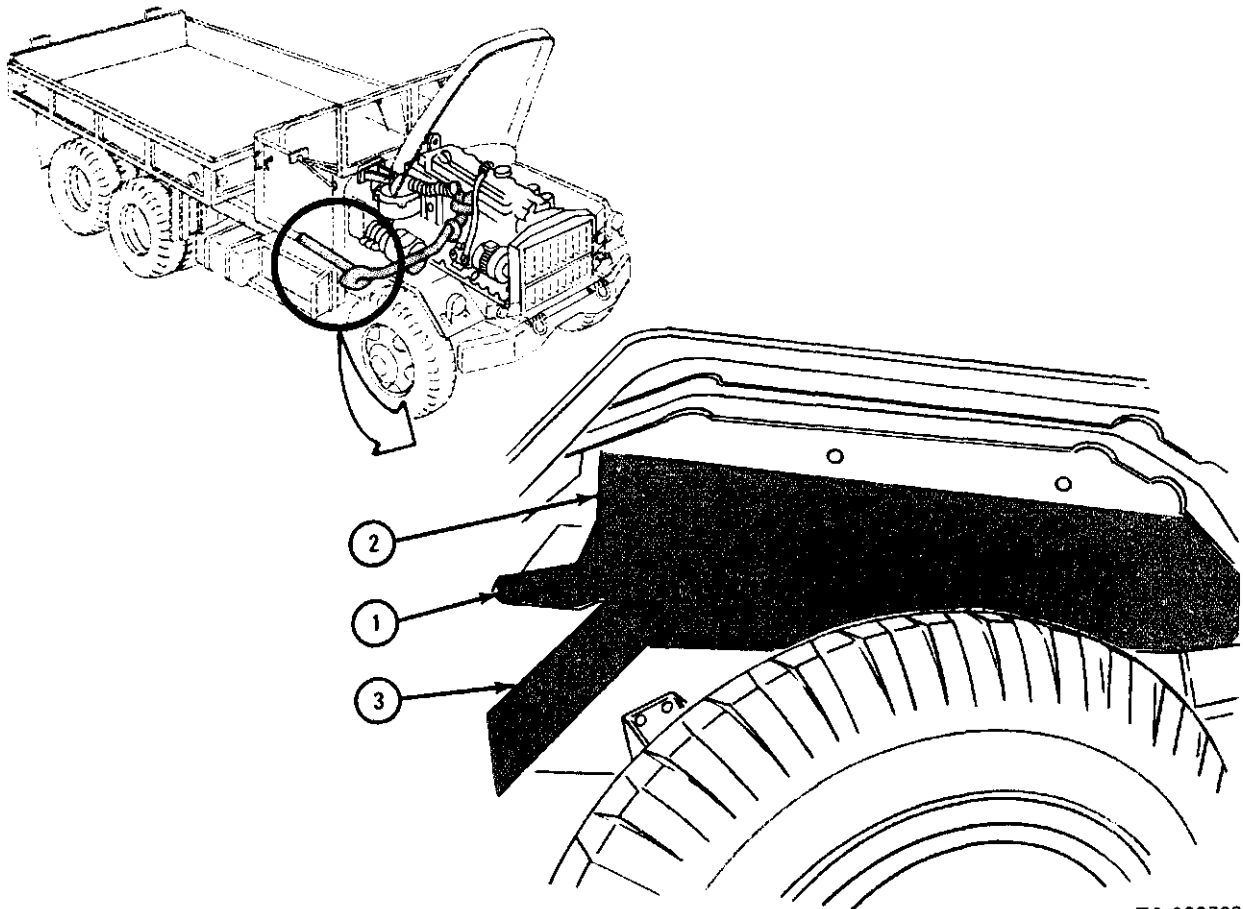

TA 080729

FRAME 7

- Soldier A 1. Using 9/16-inch wrenches, unscrew and take off three locknuts (1) and capscrews (2).
- Soldier B 2. Hold front exhaust pipe (3) so it does not fall.
- Soldier A 3. Takeoff front exhaust pipe (3) and gasket (4) . Throw away gasket.
- GO TO FRAME 8

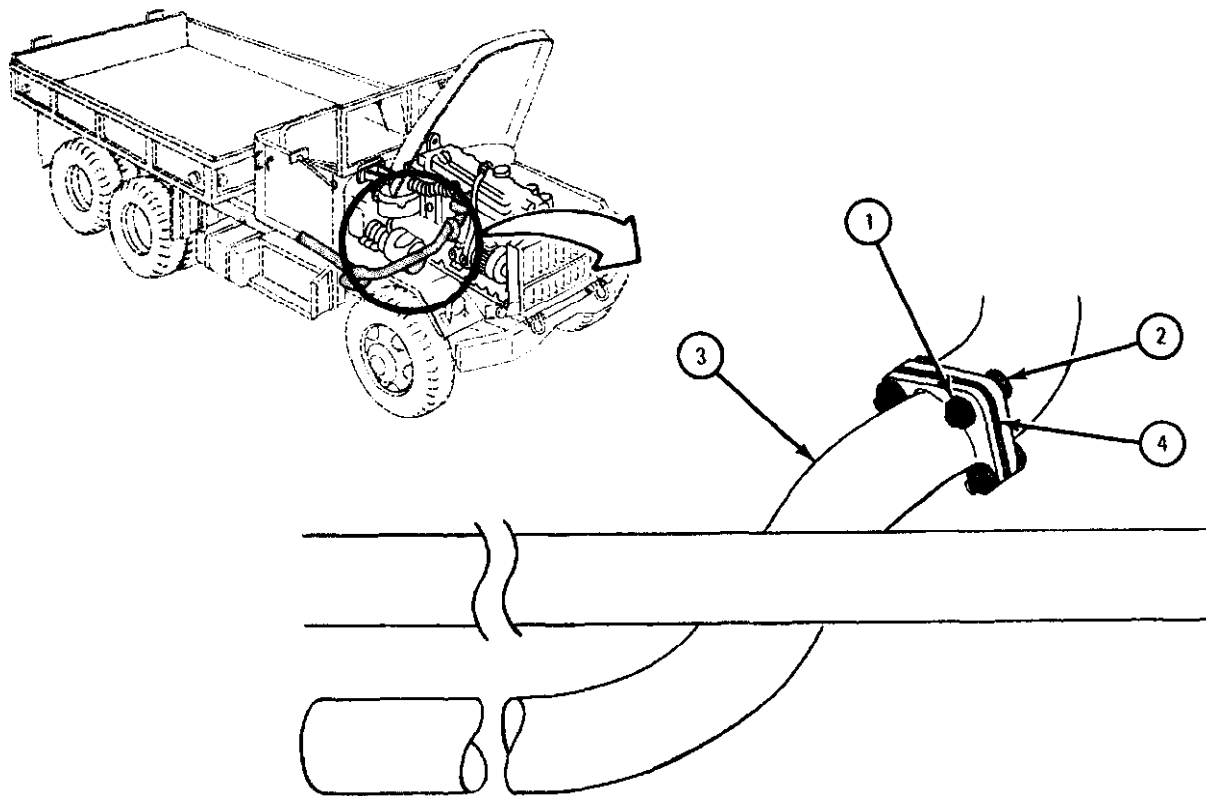

TA 080730

FRAME 8

1. Using 9/16-inch wrenches, unscrew and take off four locknuts (1) and capscrews (2) while holding exhaust manifold elbow (3).
2. Take off manifold elbow (3) and gasket (4). Throw away gasket.

END OF TASK

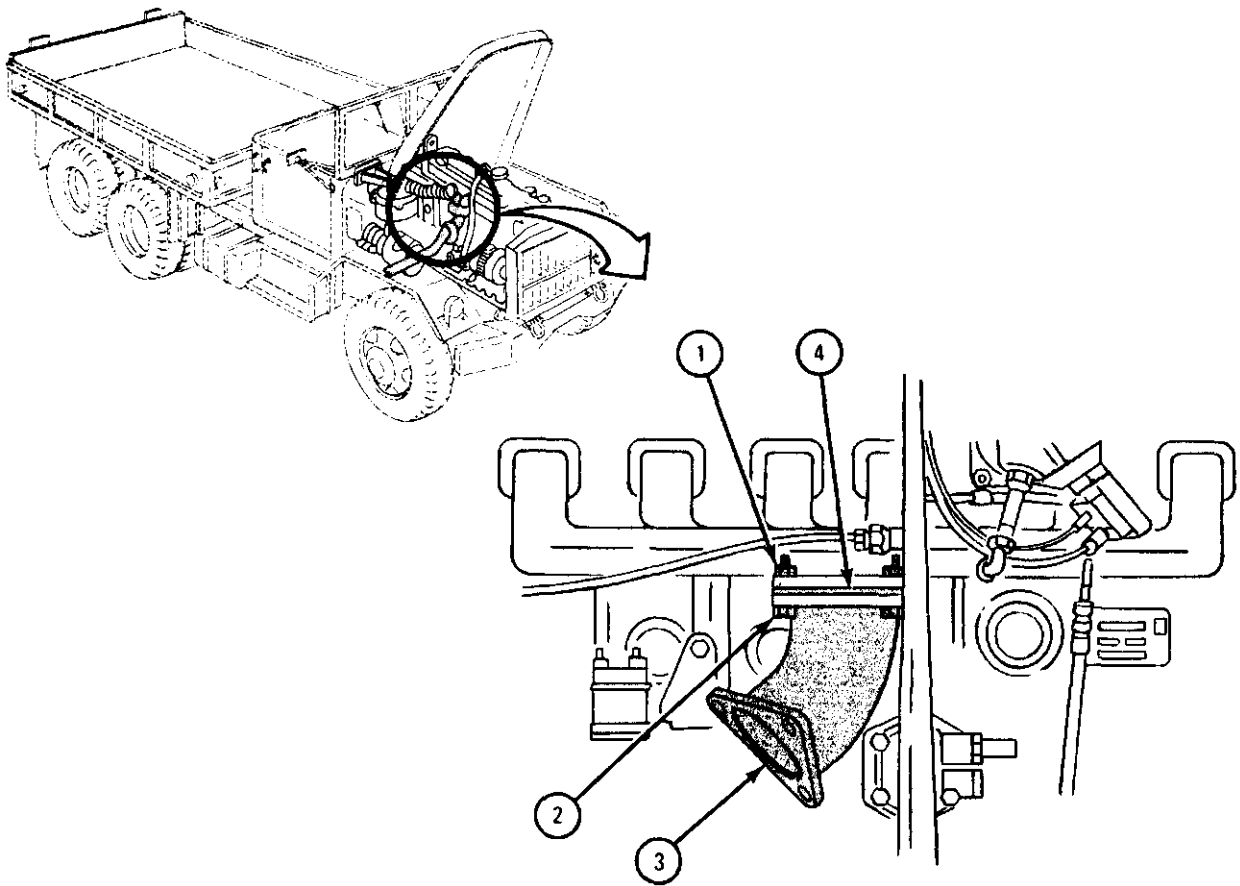

TA 080731

c. Replacement.

FRAME 1

1. Put exhaust manifold elbow (1) with gasket (2) up to exhaust manifold (3) and aline holes.
2. Using 9/16-inch wrenches, screw in and tighten two capscrews (4) and locknuts (5).

GO TO FRAME 2

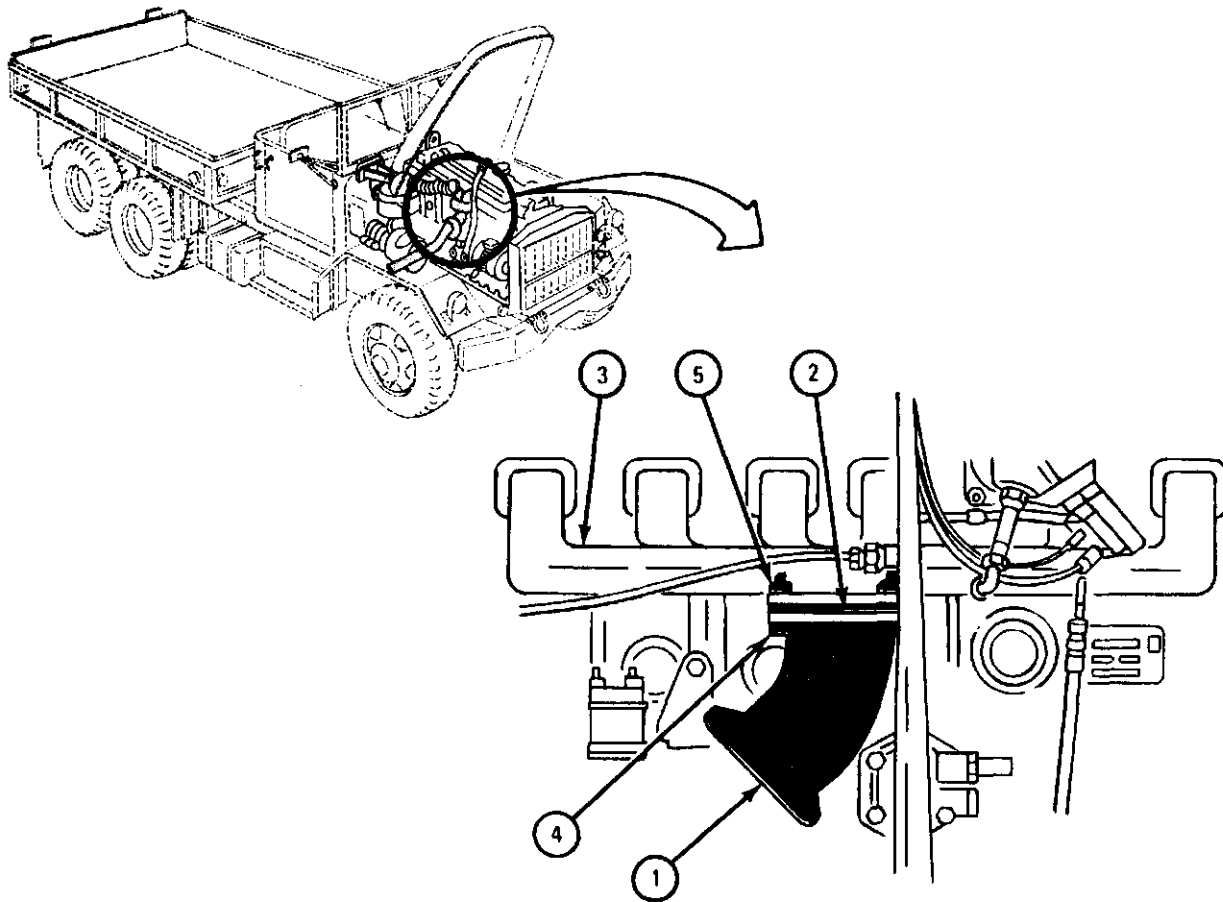

TA 080732

FRAME 2

1. From under right front fender (1), put in front exhaust pipe (2) as shown.
2. Using 9/16-inch wrench, screw in and tighten capscrew (3).

GO TO FRAME 3

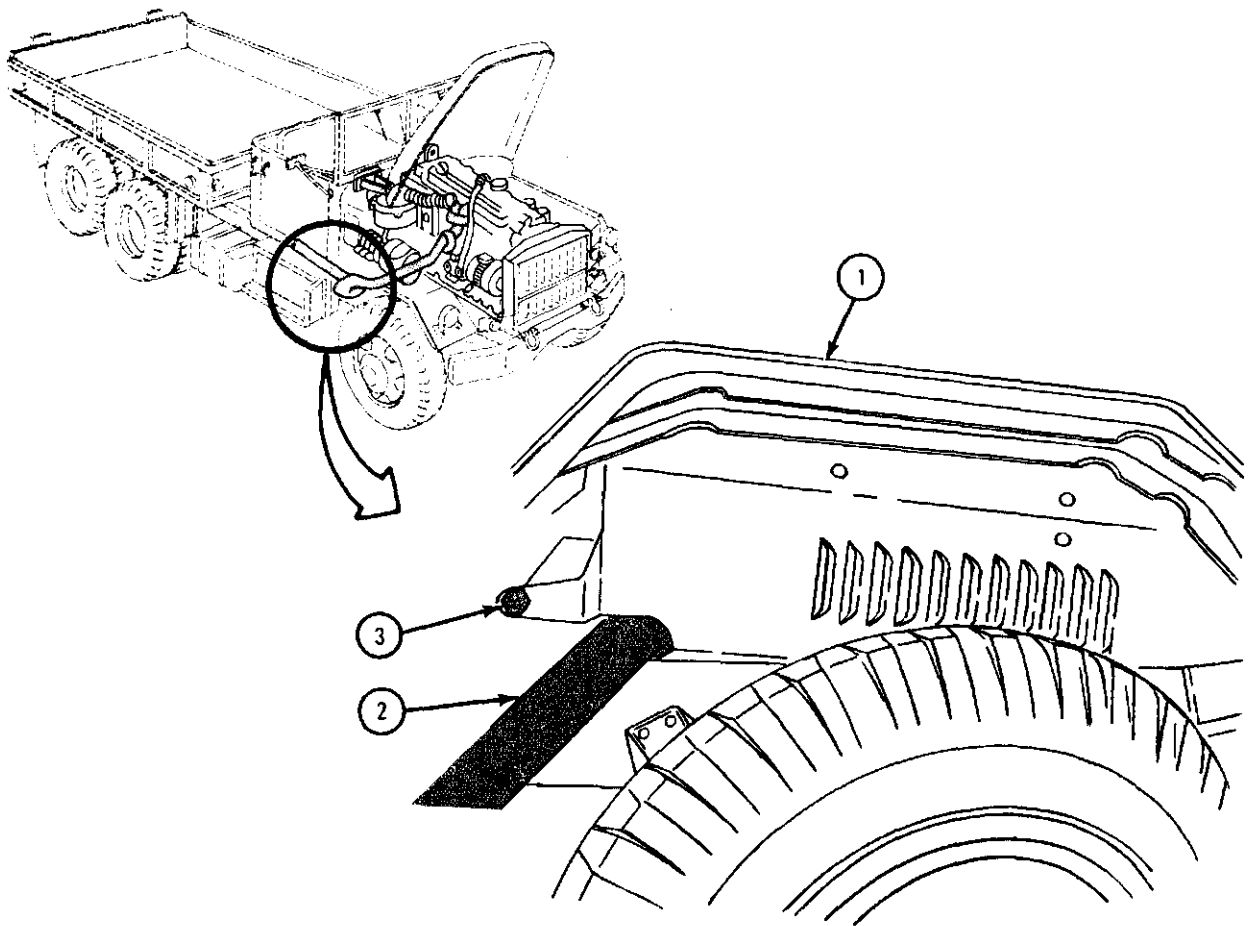

TA 080733

FRAME 3

Soldier A 1. Put front exhaust pipe (1) in place with gasket (2), and aline holes.

Soldier B 2. Using 9/16-inch wrenches, screw in and tighten three capscrews (3) and locknuts (4).

GO TO FRAME 4

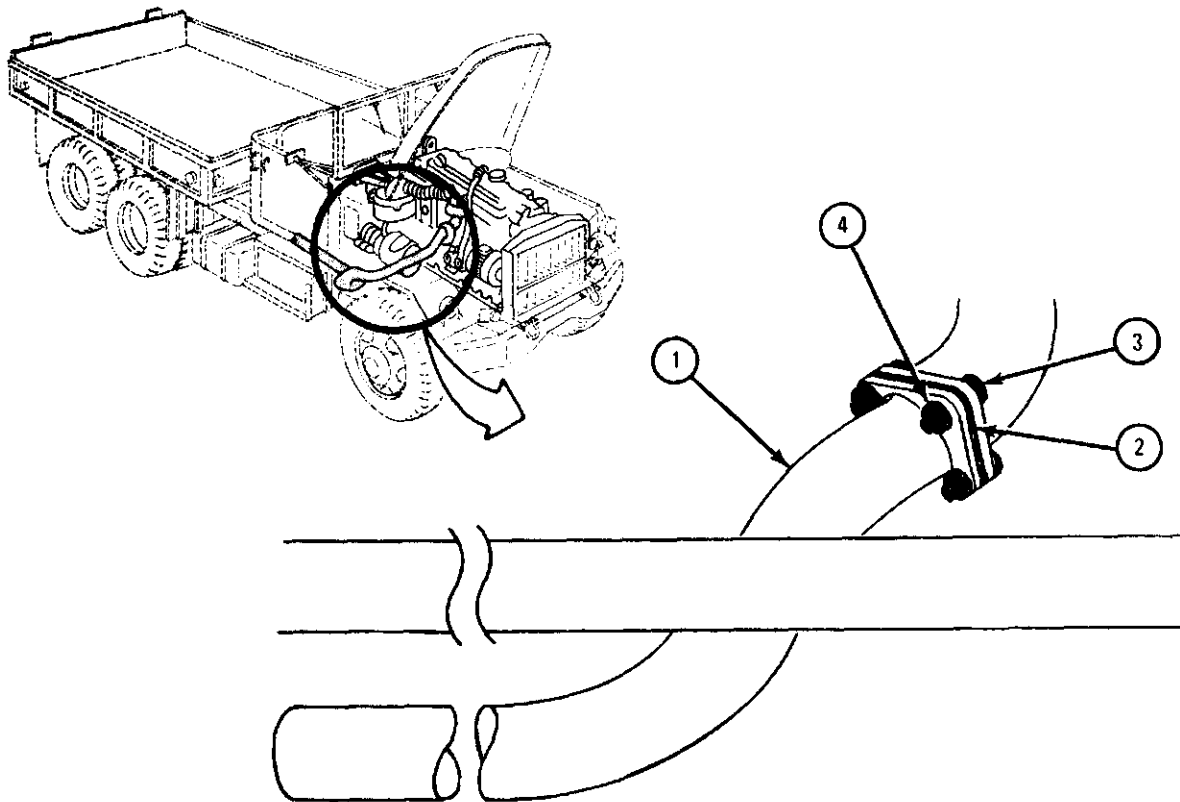

TA 080734

FRAME 4

- Soldier A
1. Put large end of muffler (1) toward front of truck.
 2. Spread open muffler loop clamp (2) and put it on muffler (1).
 3. Push large end of muffler (1) over front exhaust pipe (3) as far as it can go and hold in place.
- Soldier B
4. Aline holes on muffler loop clamp (2) and bracket (4), then screw in two capscrews (5) and locknuts (6).
 5. Using 9/16-inch wrenches, tighten two capscrews (5) and locknuts (6).

GO TO FRAME 5

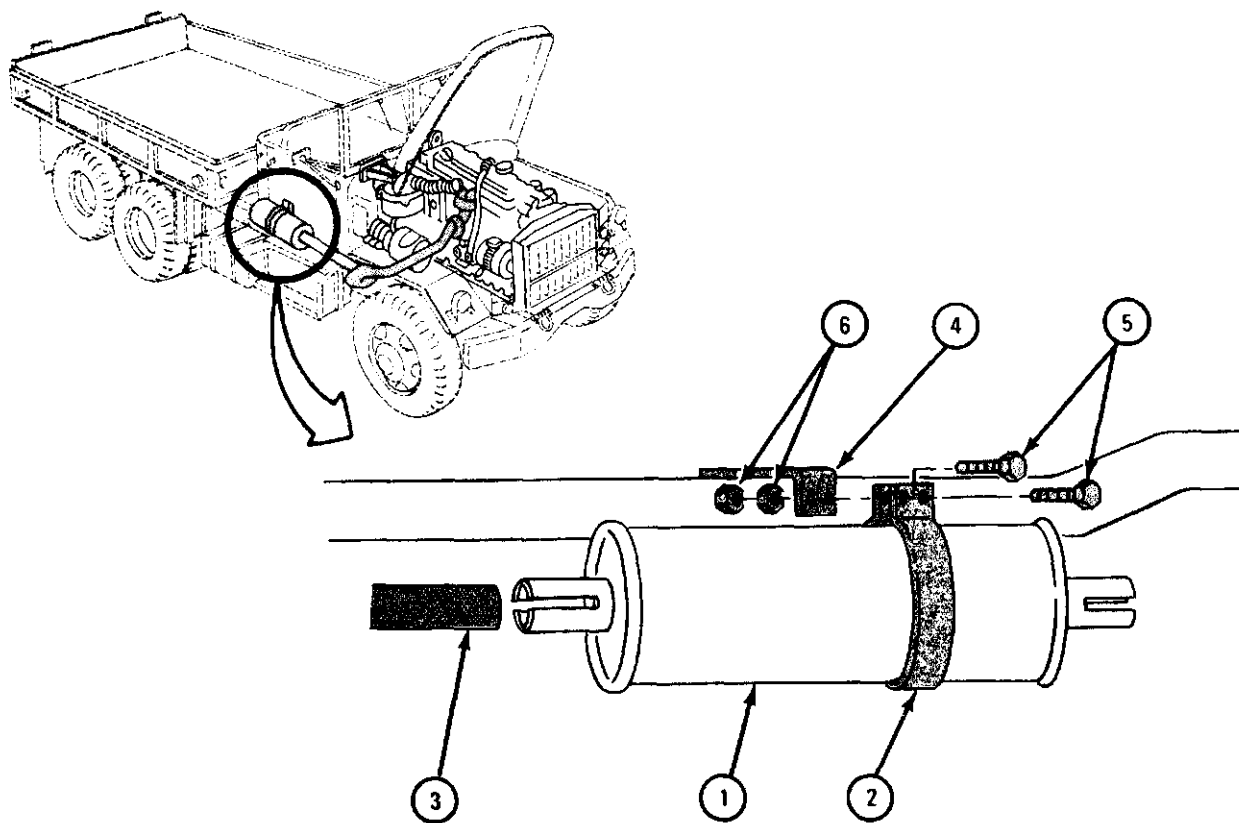

TA 080735

- Soldier A 1. Put tailpipe (1) between rear tire (2) and frame (3). Push tailpipe into muffler (4) and hold in place.
- Soldier B 2. Spread open loop clamp (5) and put it on tailpipe (1). Aline hole in loop clamp with screw hole in bracket (6).
3. Screw in capscrew (7) with locknut (8).
4. Aline tailpipe (1) to clear tire (2). Using 9/16-inch wrenches, tighten capscrew (7) with locknut (8).

GO TO FRAME 6

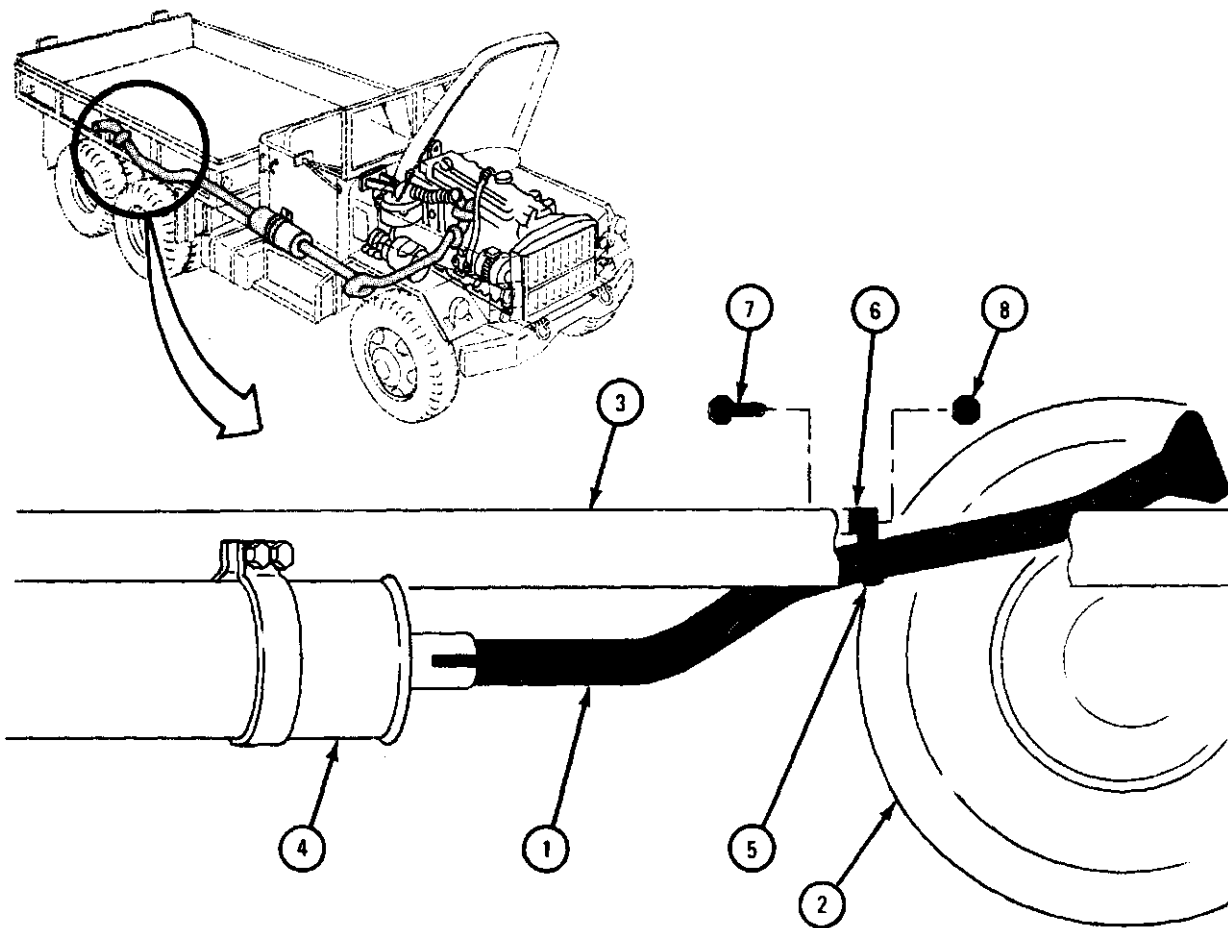

TA 080736

FRAME 6

1. Put U-bolt (1) and clamp bracket (2) on front of muffler (3). Using 9/16-inch wrench, screw on and tighten two washers (4) and nuts (5).
2. Put U-bolt (6) and clamp bracket (7) on back of muffler (3). Using 9/16-inch wrench, screw in and tighten two washers (8) and nuts (9).

GO TO FRAME 7

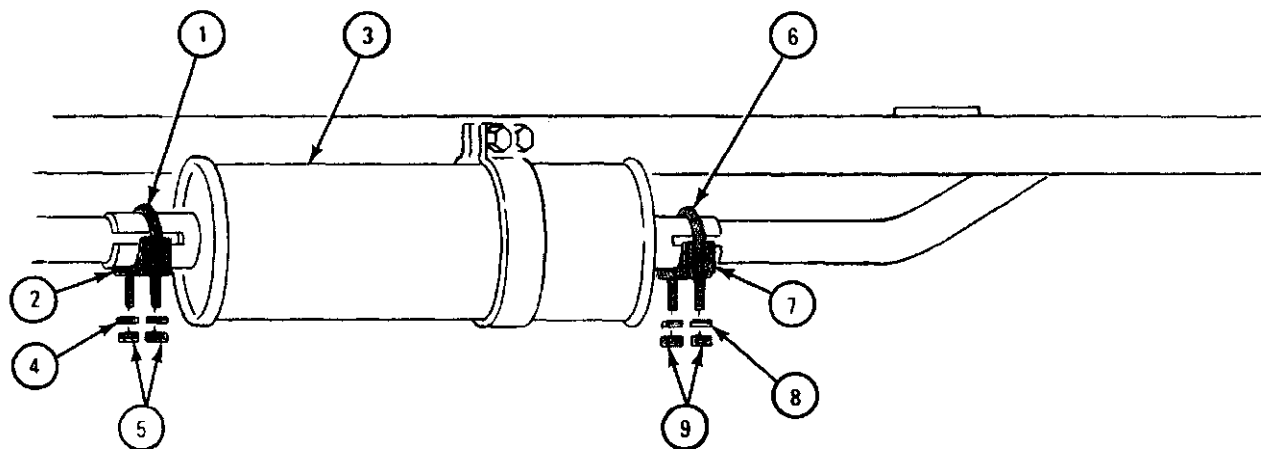

TA 080724

FRAME 7

1. Put tailpipe extension pipe (1) with gasket (2), on tailpipe (3) .
2. Aline holes and screw in three capscrews (4) and locknuts (5).
3. Using 9/16-inch wrenches, tighten three capscrews (4) and locknuts (5).

NOTE

Follow-on Maintenance Action Required:
Replace air cleaner. Refer to para 4-3.

END OF TASK

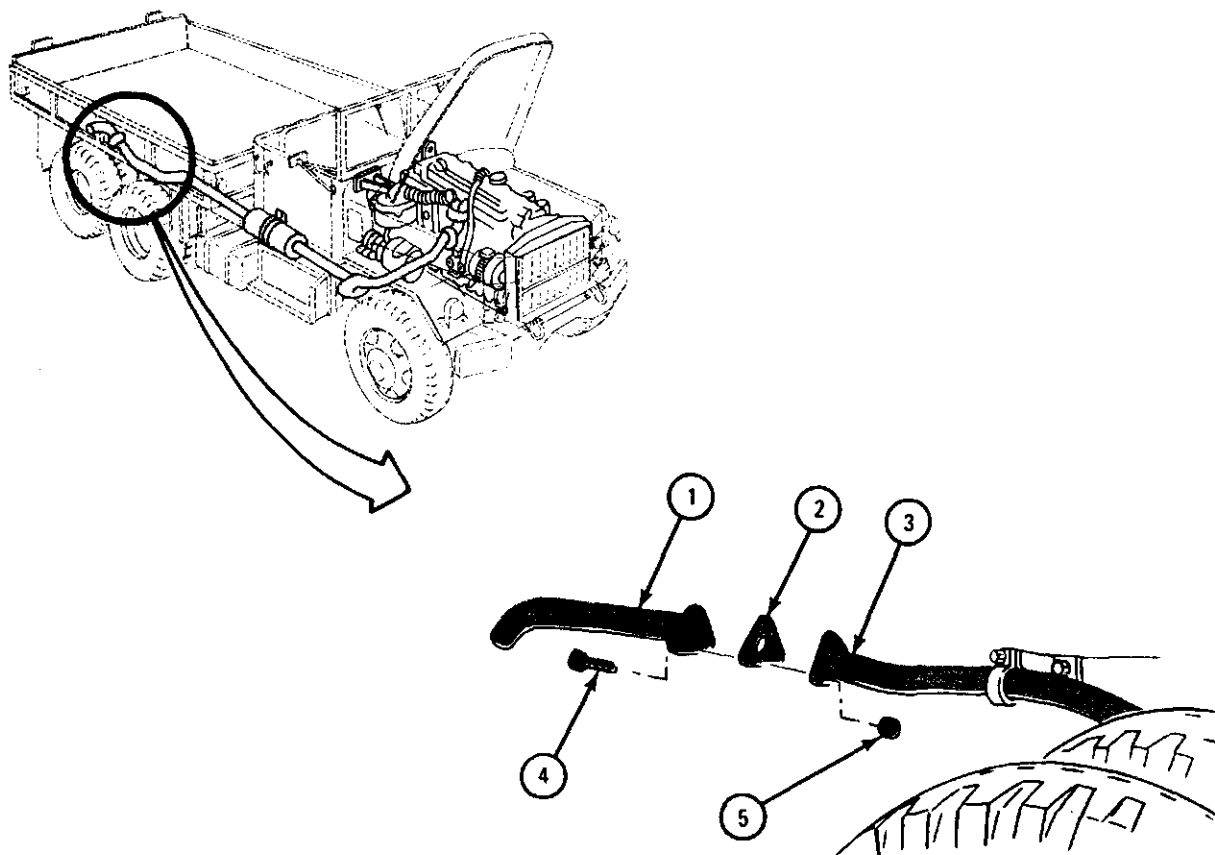

T/I 080737

5-4. EXHAUST SYSTEM (HORIZONTAL) REMOVAL AND REPLACEMENT
(TRUCKS M50A1, M50A2, AND M50A3).

TOOLS :	3/4-inch wrench (2)	6-inch extension
	9/16-inch wrench (2)	10-inch extension (2)
	1/2-inch wrench	Universal
	9/16-inch wrench	3/4-inch socket
	Hammer	Ratchet
	Chisel	Cross-tip screwdriver (Phillips type)
	Rubber mallet	Pliers

SUPPLIES: Bypass valve gasket
 Front exhaust pipe gasket
 Exhaust pipe extension pipe gasket
 Exhaust manifold elbow gasket
 Fording valve top gasket (trucks M50A1 and M50A2)
 Fording valve bottom gasket (trucks M50A1 and M50A2)
 Extension bypass pipe gasket (truck M50A3)

PERSONNEL : Two

EQUIPMENT CONDITION : Truck parked, engine off and cool, handbrake set.

a. Preliminary Procedure. Remove air cleaner. Refer to para 4-3.

WARNING

Do not work on hot exhaust systems.
 Personnel can be badly burned.

b. Removal.

FRAME 1

1. Working outside of truck and using 9/16-inch wrenches, unscrew and take off three locknuts (1) and capscrews (2).
 2. Takeoff exhaust pipe extension pipe (3) and gasket (4). Throw away gasket.
 3. Using 9/16-inch wrenches, unscrew and take off capscrew (5) and locknut (6).
- GO TO FRAME 2

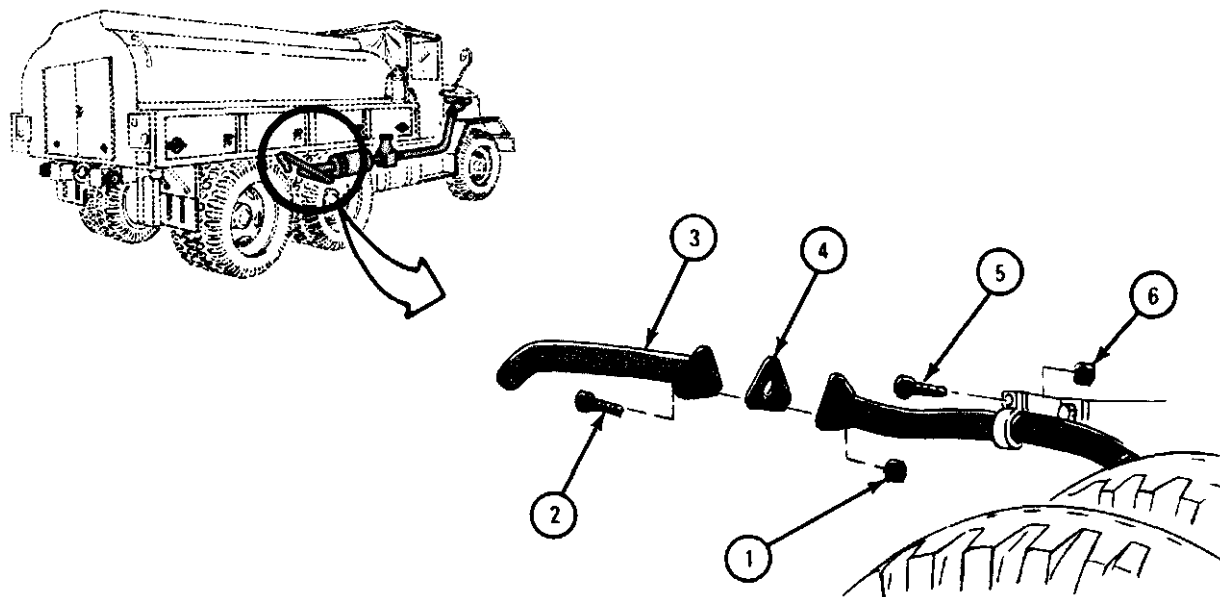

TA 080701

FRAME 2

1. Working under truck and using 1/2-inch wrench, unscrew and take off two nuts (1) , two washers (2) , and clamp bracket (3). Take off U-bolt (4).

GO TO FRAME 3

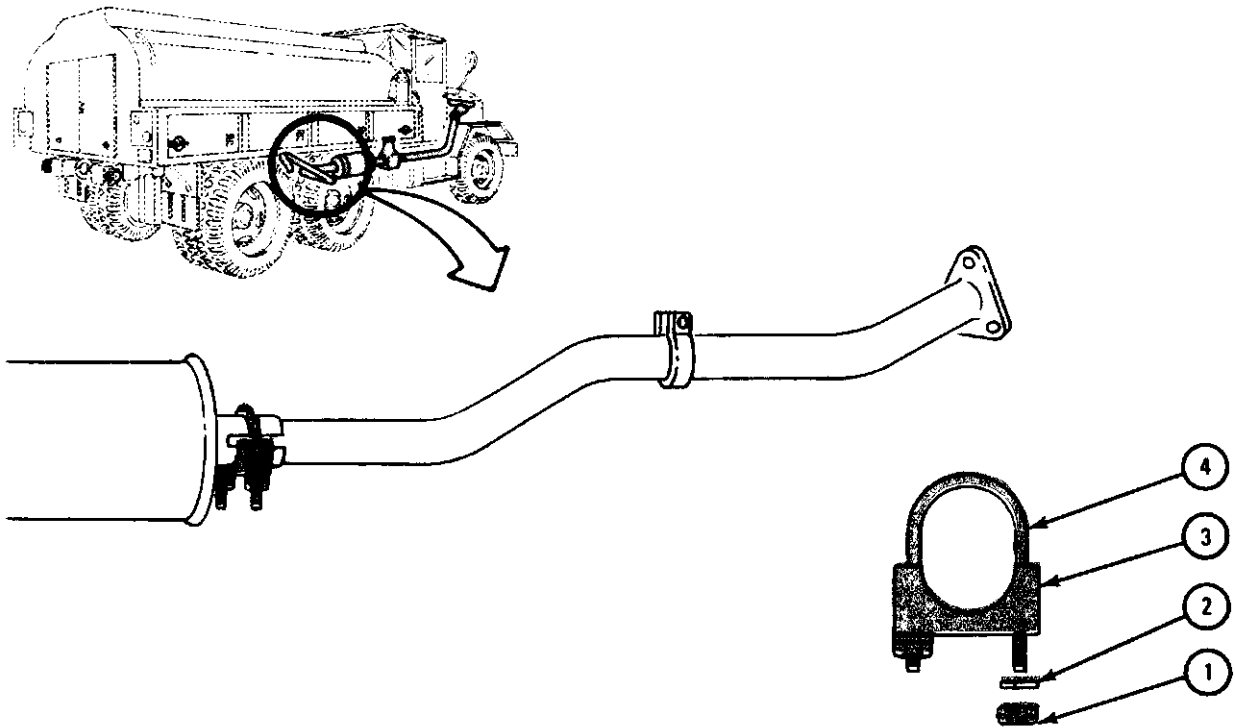

TA 080702

FRAME 3

NOTE

Exhaust pipe (1) may be stuck to muffler (2). If needed, use hammer and chisel to loosen exhaust pipe.

1. Take out exhaust pipe (1) from muffler (2) by turning it back and forth,
2. Slide off clamp (3).

GO TO FRAME 4

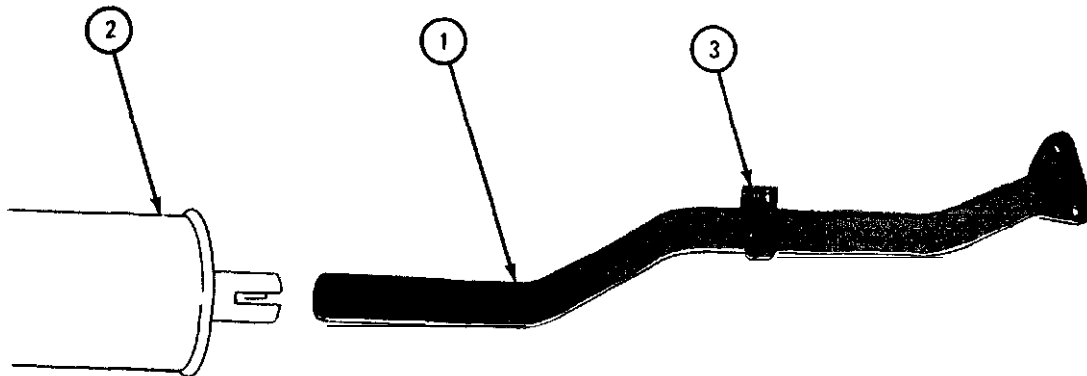

TA 080703

FRAME 4

1. Using 9/16-inch wrench, unscrew and take off two nuts (1), two washers (2), and clamp bracket (3). Take off U-bolt (4).
2. Using 9/16-inch wrenches, unscrew and take off two nuts (5) and capscrews (6) from muffler loop clamp (7).

GO TO FRAME 5

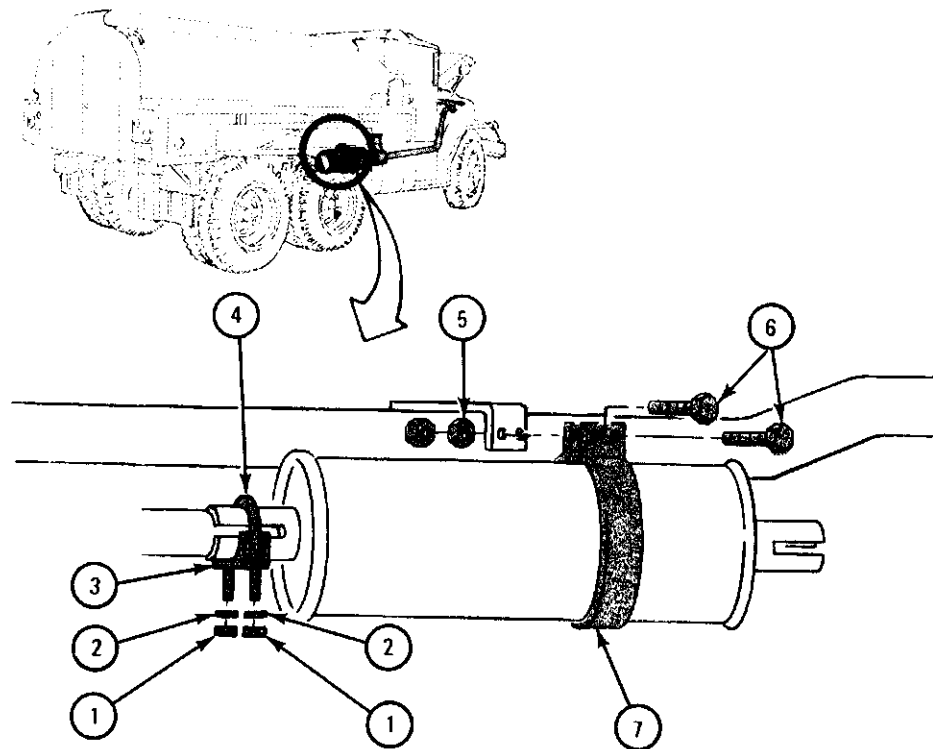

TA 080704

FRAME 5

NOTE

Muffler (1) may be stuck to bypass valve (2). If needed, use hammer and chisel to loosen muffler.

1. Take off muffler (1) by turning it back and forth.
2. Spread muffler loop clamp (3) and take it off.

GO TO FRAME 6

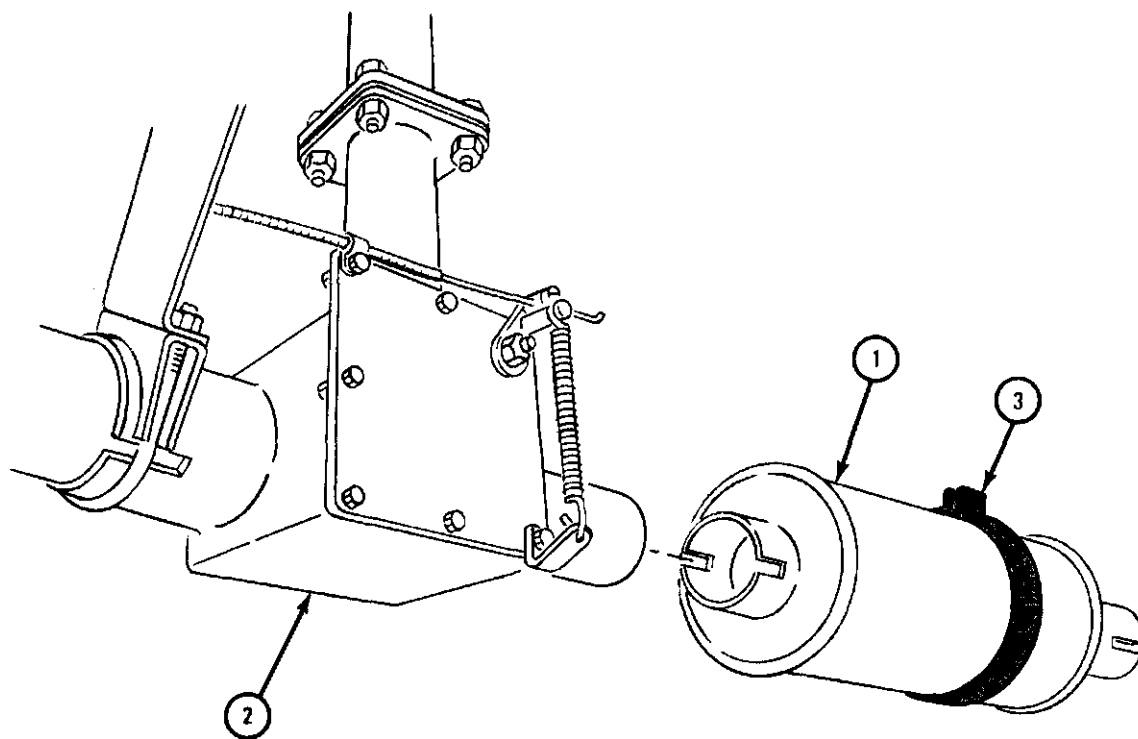

TA 080705

FRAME 6

1. Using 3/4-inch wrenches, unscrew and take off four nuts (1) and capscrews (2).
2. Using 7/16-inch wrenches, unscrew and take off locknut (3) and capscrews (4). Spread open and take off cable clamp (5).
3. Using screwdriver, loosen screw (6). Using pliers, straighten front of cable (7) and take out cable.

GO TO FRAME 7

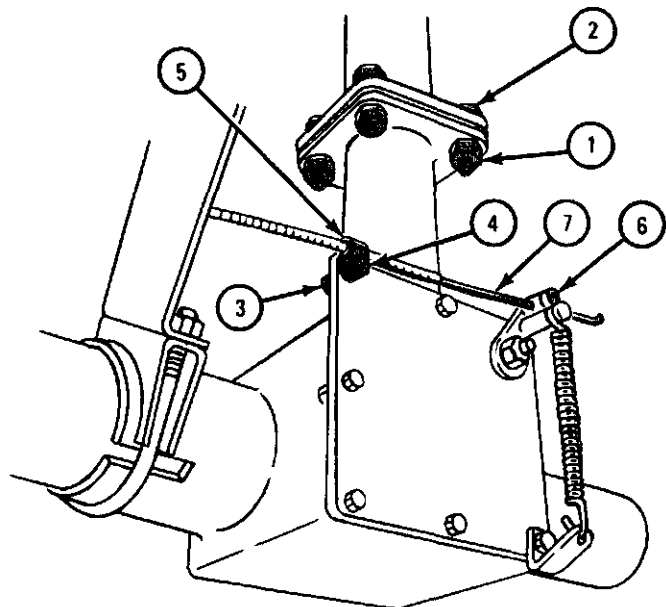
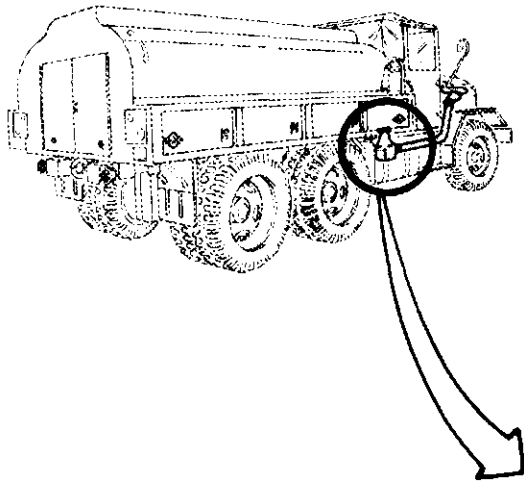

TA 080706

FRAME 7

1. Using 9/16-inch wrench, unscrew and take off two nuts (1) and washers (2). Take off U-bolt (3) and bracket (4).

NOTE

Bypass valve (5) maybe stuck to exhaust pipe (6).
If needed, use hammer and chisel to pry up ends of
bypass valve.

2. Using rubber mallet, tap off bypass valve (5).
3. Take off and throw away gasket (7).

IF WORKING ON TRUCK M50A1 OR M50A2, GO TO FRAME 8.
IF WORKING ON TRUCK M50A3, GO TO FRAME 9

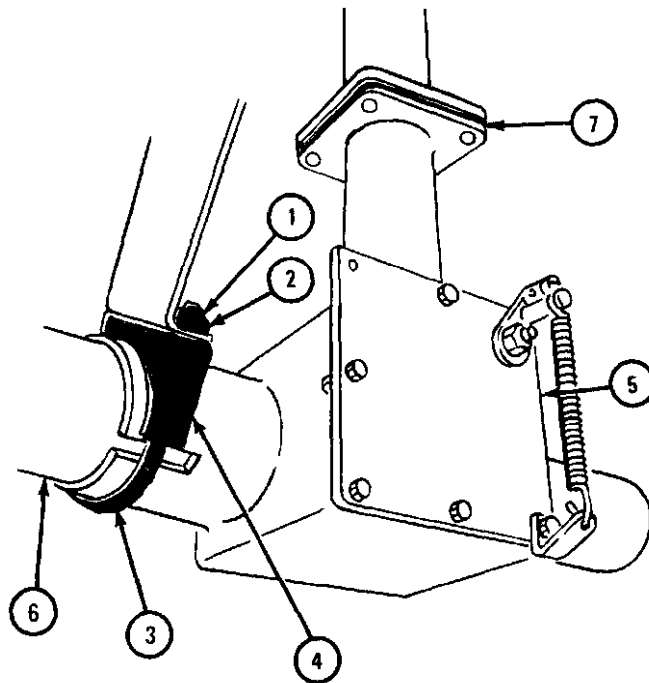

TA 080707

FRAME 8

- Soldier A 1. Working behind cab using 3/4-inch wrench, hold four capscrews (1), Tell soldier B when ready.
- Soldier B 2. Working under truck using 3/4-inch socket with two 10-inch extensions and universal, unscrew and take off four locknuts (2).
3. Take off bypass extension pipe (3) and gasket (4). Throw away gasket.
4. Hold fording valve (5) .
- Soldier A 5. Using 3/4-inch wrenches, unscrew and take out four capscrews (6) and four locknuts (7).
- Soldier B 6. Take off fording valve (5) and gasket (8).
- GO TO FRAME 10

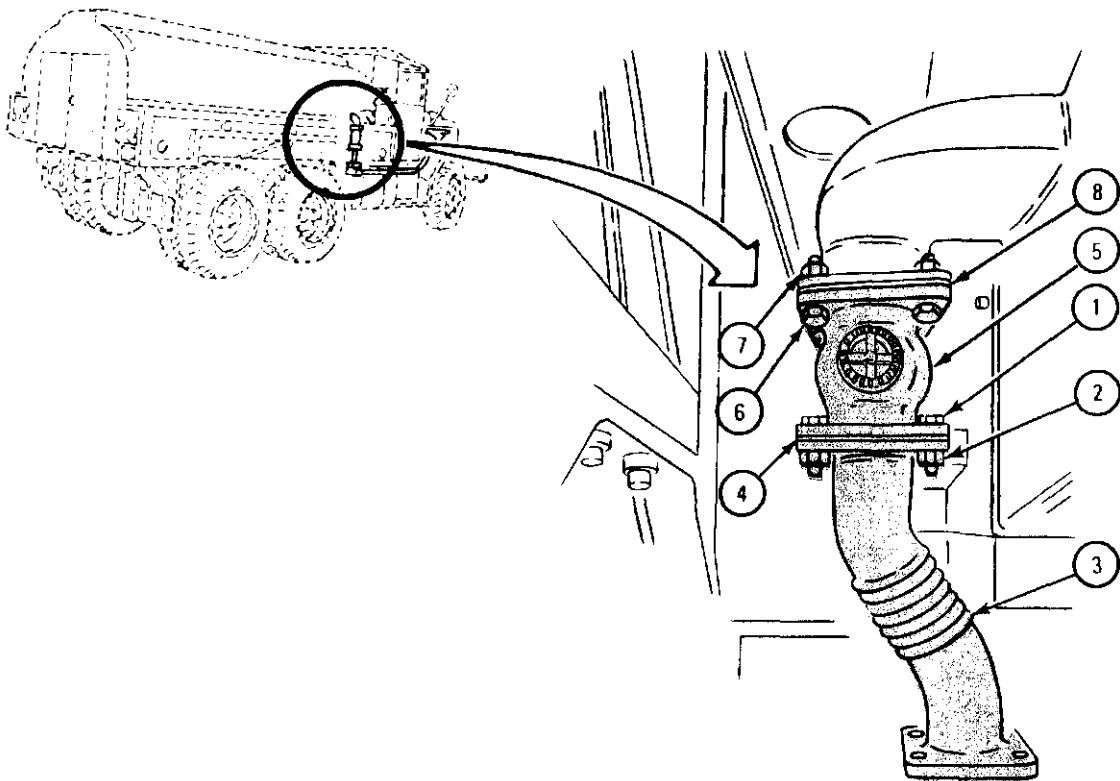

TA 080708

FRAME 9

- Soldier A 1. Working under truck, hold bypass extension (1).
- Soldier B 2. Working behind cab using 3/4-inch wrenches, unscrew and take off four cap screws (2) and four locknuts (3).
- Soldier A 3. Take off bypass extension (1) and gasket (4).
- GO TO FRAME 10

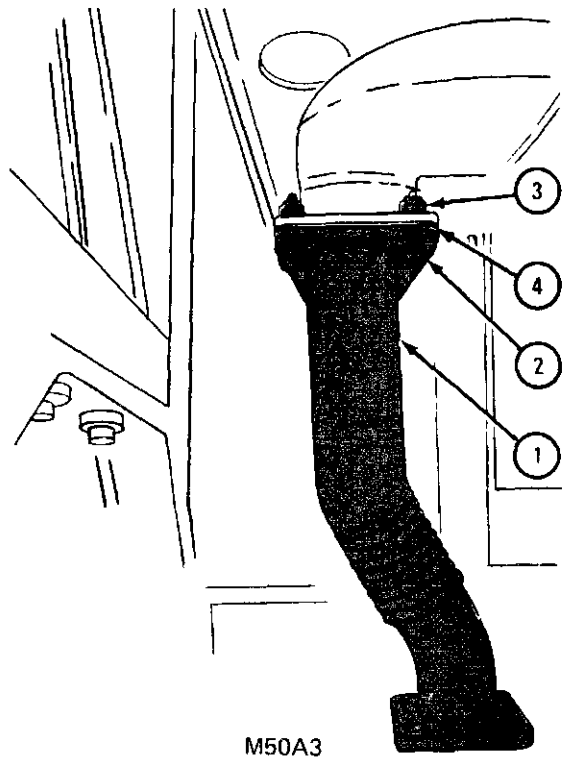
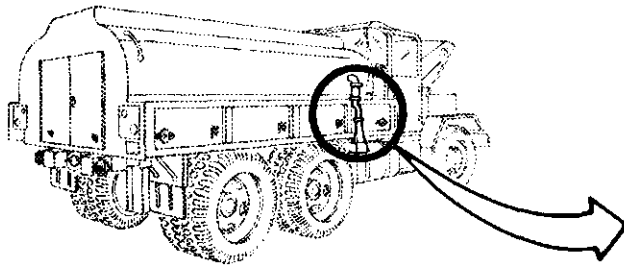

TA 080709

FRAME 10

1. Using 9/16-inch wrench, unscrew and take out capscrew (1).
2. Pull pebble shield (2) away from front exhaust pipe (3) so pipe can be taken out.

GO TO FRAME 11

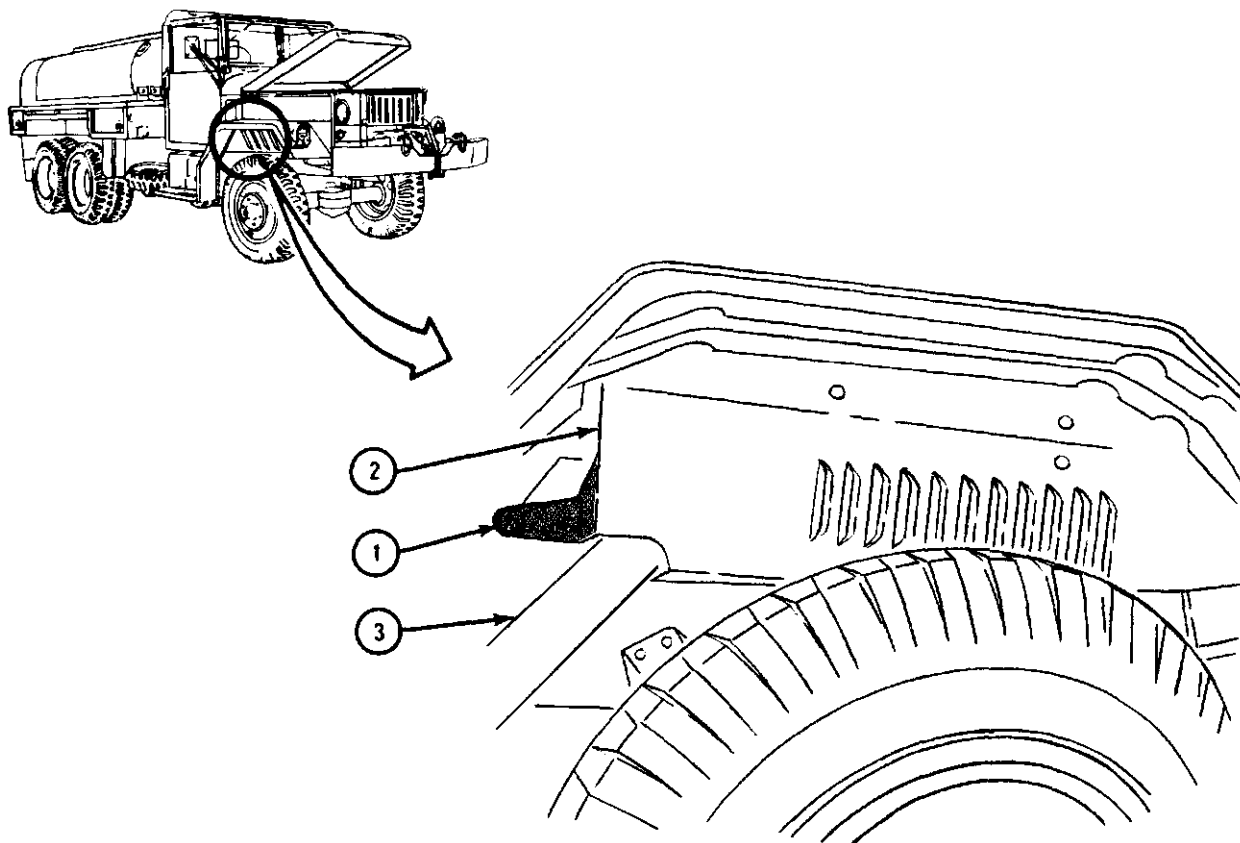

TA 080710

FRAME 11

1. Using 9/16-inch wrenches, loosen three locknuts (1) and capscrews (2).
 2. Takeoff front exhaust pipe (3) and gasket (4). Throw away gasket.
- GO TO FRAME 12

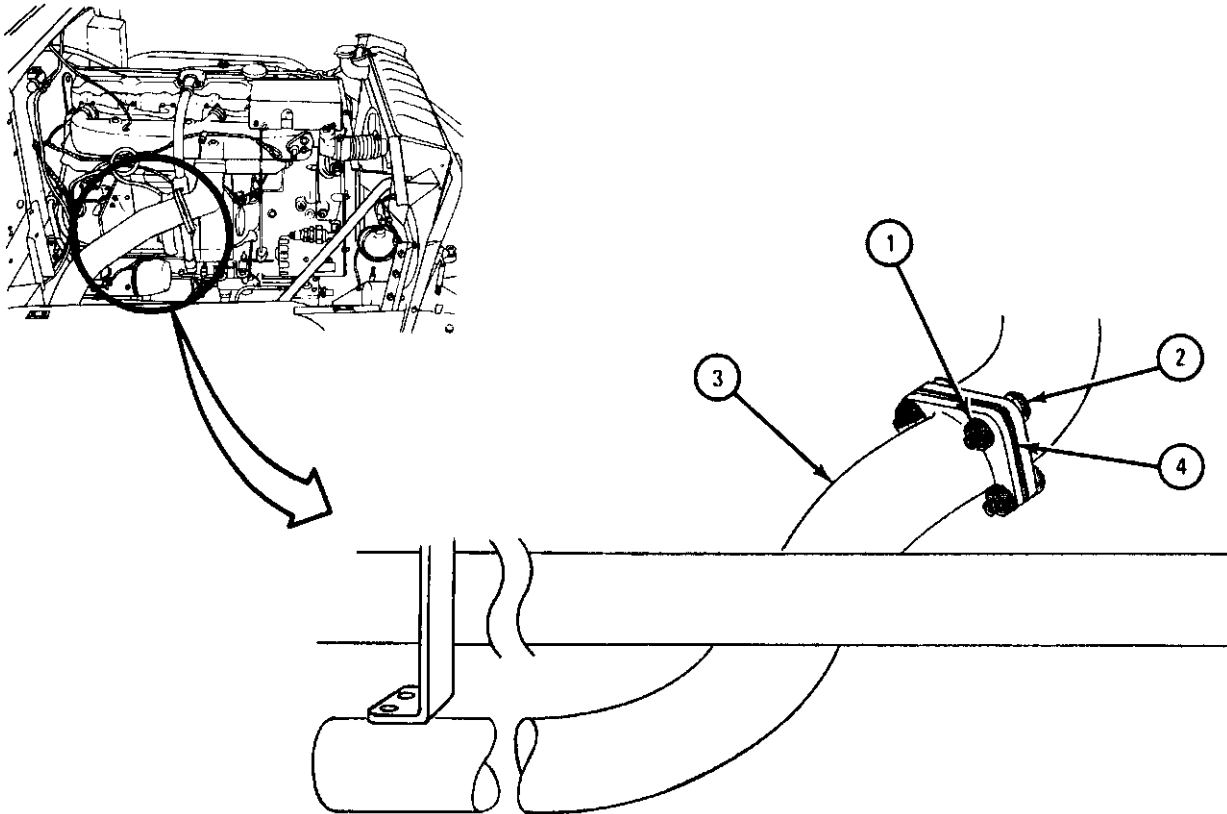

TA 080711

FRAME 12

1. Using 9/16-inch wrenches, unscrew and take off four locknuts (1) and two cap screws (2) while holding exhaust manifold elbow (3).
2. Take off manifold elbow (3) and gasket (4). Throw away gasket.

END OF TASK

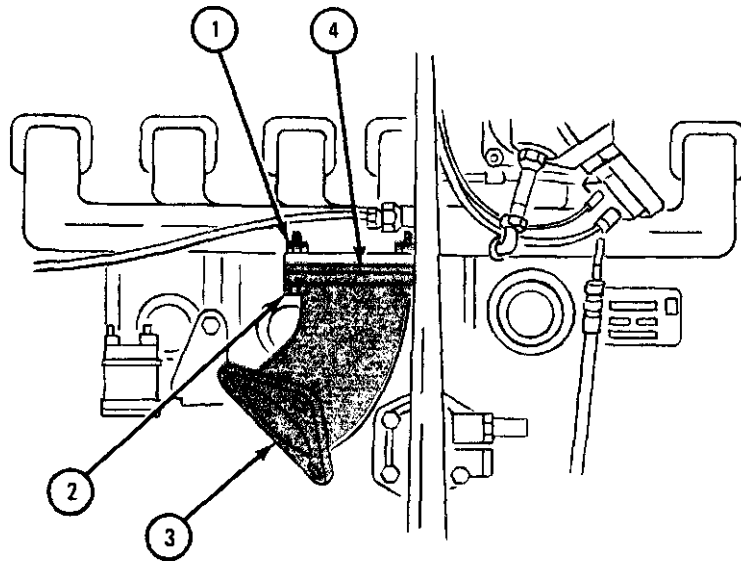

TA 080712

c. Replacement.

FRAME 1

1. Put exhaust manifold elbow (1) with gasket (2) on exhaust manifold (3) and align holes for two capscrews (4).

NOTE

There are two studs on exhaust manifold (3). Two locknuts go on these studs.

2. Using 9/16-inch wrenches, screw in and tighten two capscrews (4) and four locknuts (5).

GO TO FRAME 2

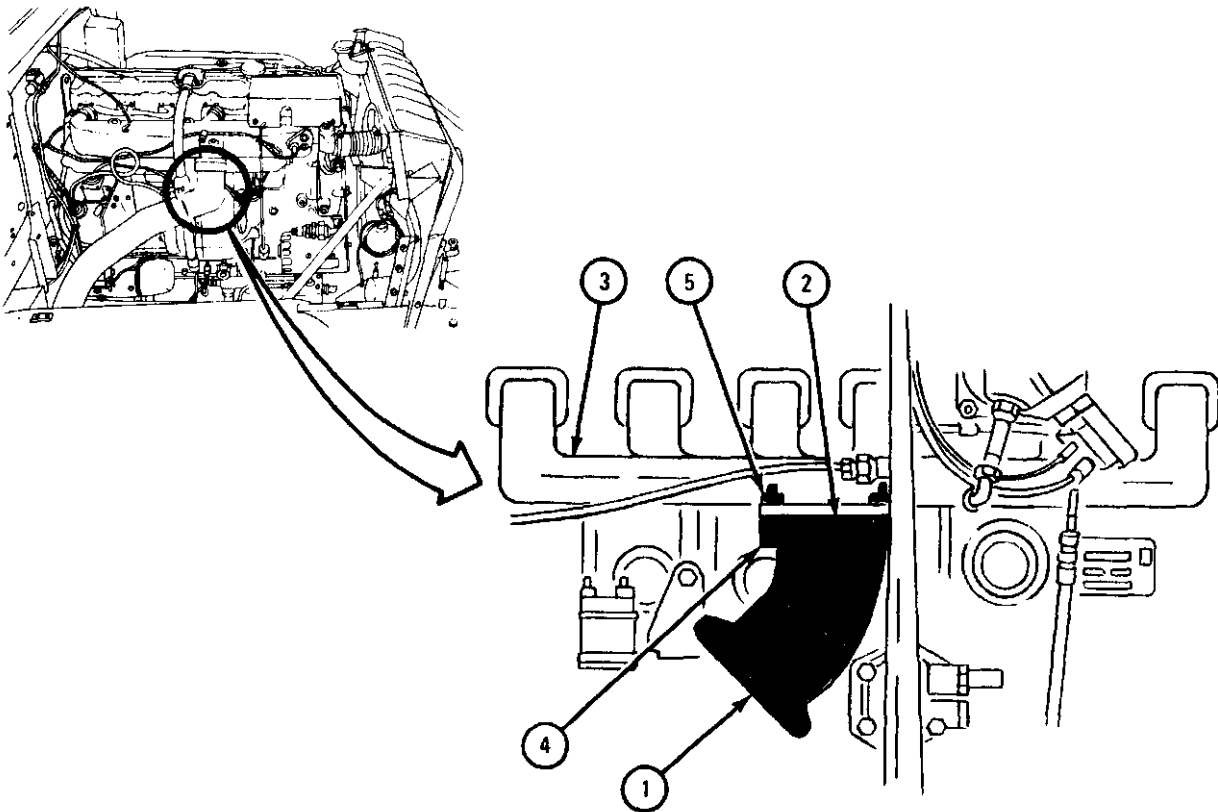

TA 080713

FRAME 2

1. From under right front fender (1), put in front exhaust pipe (2) as shown.
 2. Using 9/16-inch wrench, screw in and tighten capscrew (3).
- GO TO FRAME 3

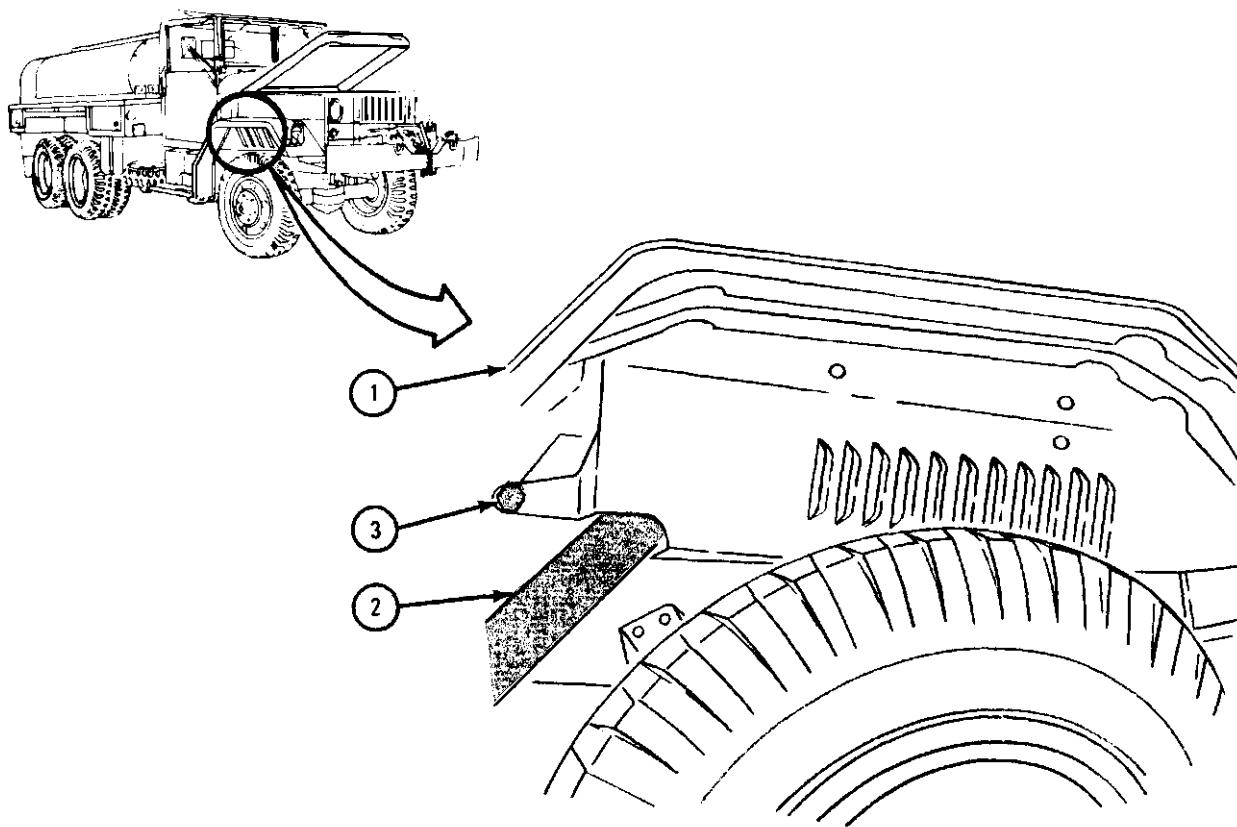

TA 080714

FRAME 3

WARNING

Exhaust pipe flange is slotted. Aline flange correctly so exhaust does not leak. Leaking exhaust can cause serious injury or death to personnel.

1. Put front exhaust pipe (1) and gasket (2) in place and aline holes.
2. Using 9/16-inch wrenches, loosely screw in three capscrews (3) with locknuts (4).

GO TO FRAME 4

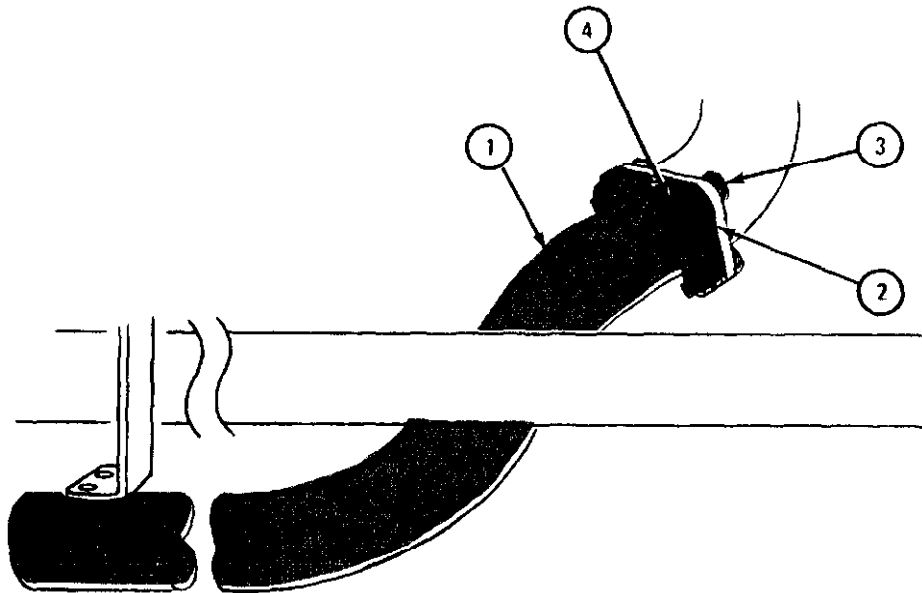

TA 080715

FRAME 4

1. Working under truck, push exhaust bypass valve (1) on engine pipe (2) as far as it can go.
2. Put on clamp assembly (3) so threaded studs go through bracket (4).
3. Screw on two washers (5) and nuts (6).

GO TO FRAME 5

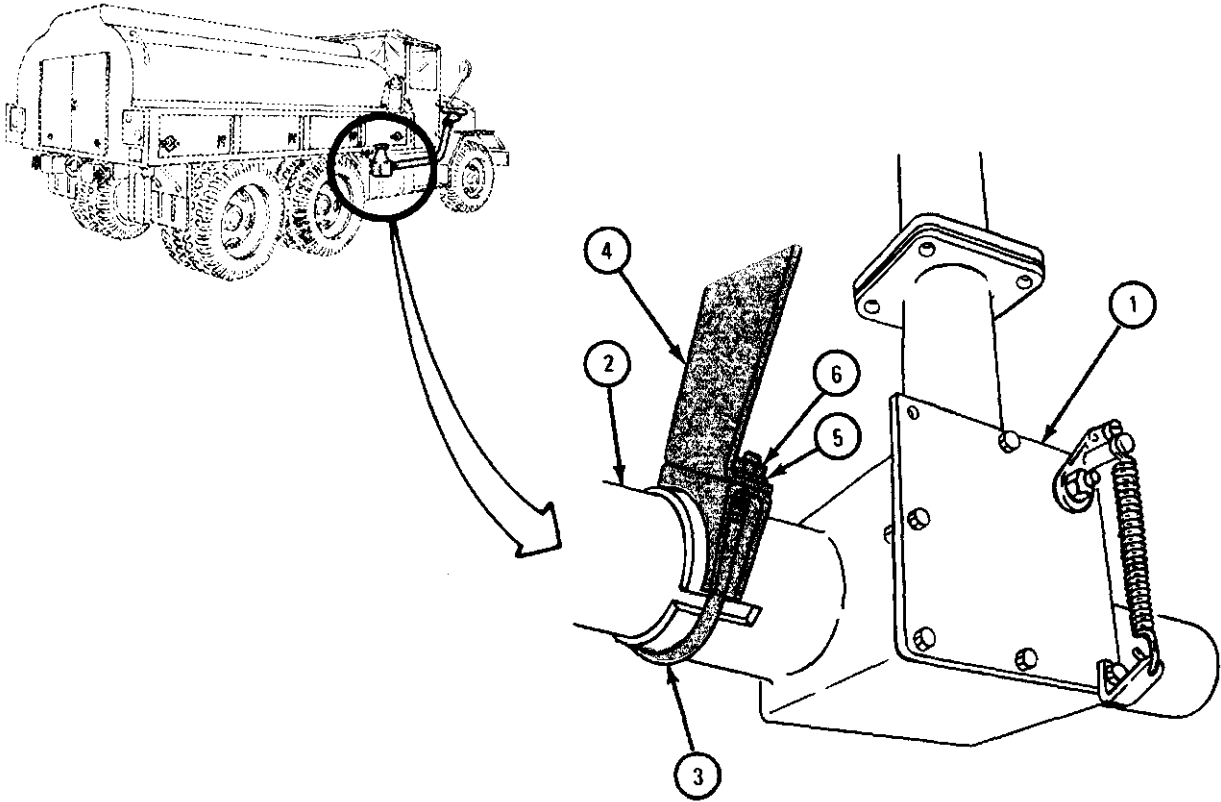

TA 080716

FRAME 5

1. Using 9/16-inch wrenches, tighten three capscrews (1) with locknuts (2).
GO TO FRAME 6

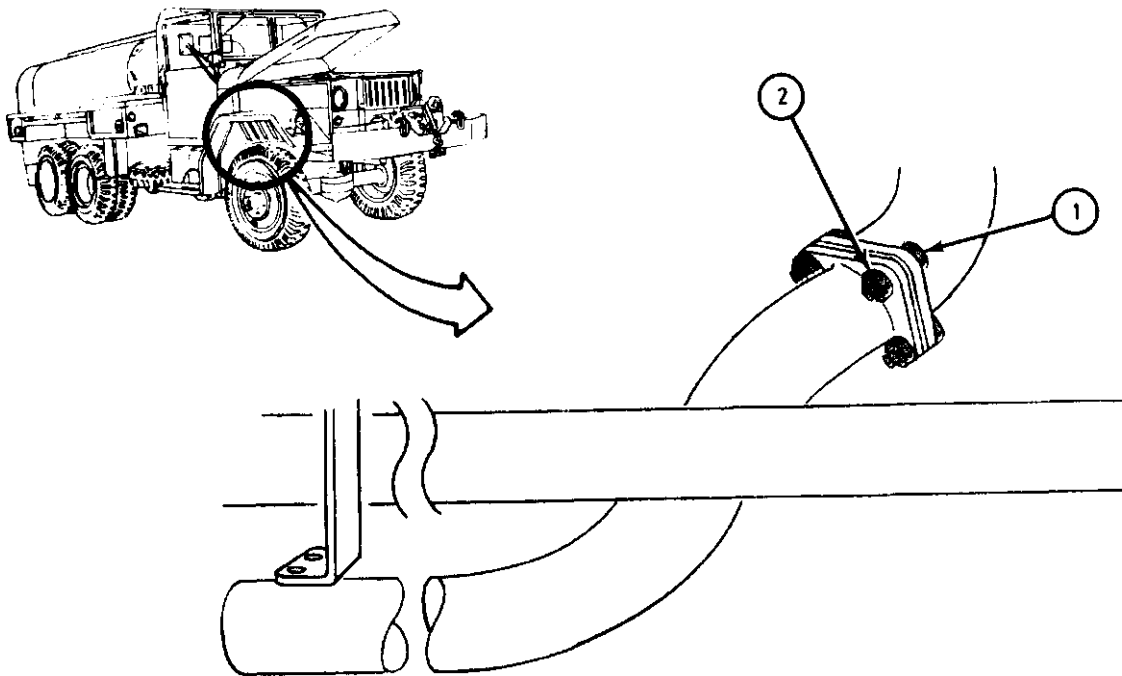

TA 089411

FRAME 6

1. Put cable clamp (1) with cable (2) on bypass valve (3).
2. Aline holes and put in capscrew (4) and screw on locknut (5).
3. Put end of cable (2) 1/2 inch through hole in lever (6) and using screwdriver, tighten screw (7). Using pliers, bend cable end at 45° angle.
4. While holding lever (6) towards back of truck, slide cable case (2) in clamp (1) until there is no slack between clamp and lever.
5. Using 7/16-inch wrenches, tighten locknut (5) and cap screw (4).

GO TO FRAME 7

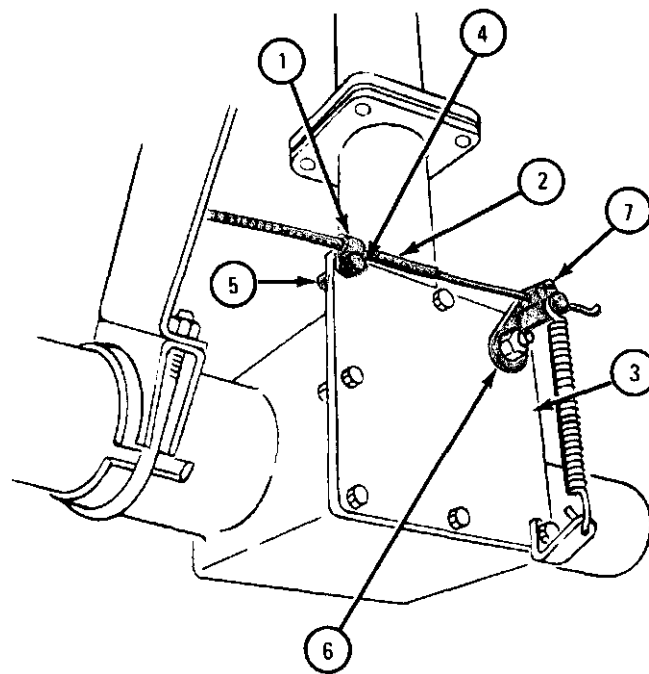

TA 080717

FRAME 7

1. Put exhaust bypass extension pipe (1) on bypass valve (2) with gasket (3).
2. Aline four holes and put in four capscrews (4) and loosely screw on four locknuts (5).

IF WORKING ON TRUCK M50A1 OR M50A2 , GO TO FRAME 8.

IF WORKING ON TRUCK M50A3, GO TO FRAME 9

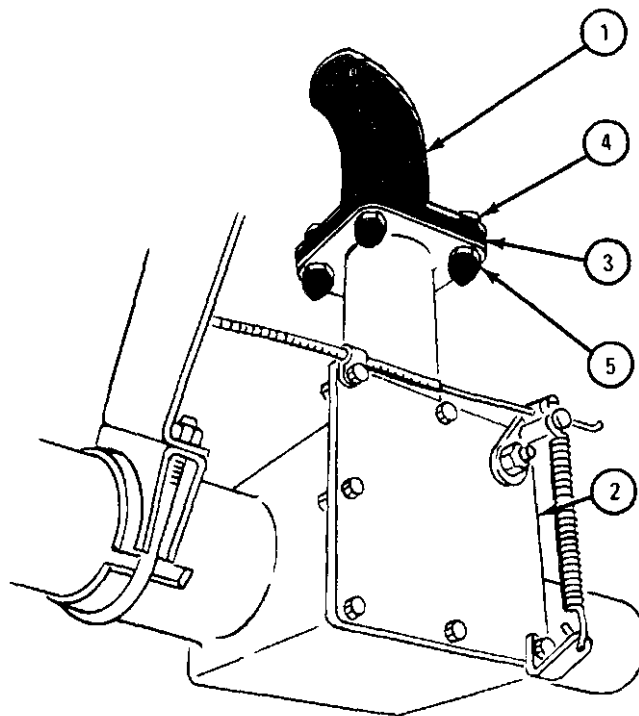

TA 080718

FRAME 8

- Soldiers A and B 1. Put fording valve assembly (1) with top gasket (2) and bottom gasket (3) in place as shown.
2. Aline holes in top and bottom of fording valve assembly (1).
- Soldier A 3. Hold fording valve assembly (1).
- Soldier B 4. Working behind cab, put four capscrews (4) in top of fording valve assembly (1) and screw on four locknuts (5). Put four capscrews (6) in bottom of fording valve assembly.
5. Using 3/4-inch wrenches, hold four locknuts (5) and screw on and tighten four capscrews (4).
- Soldier A 6. Using 3/4-inch wrench, hold four capscrews (6).
- Soldier B 7. Working under truck, using 3/4-inch socket, two 10-inch extensions and universal, screw on and tighten four locknuts (7).

GO TO FRAME 10

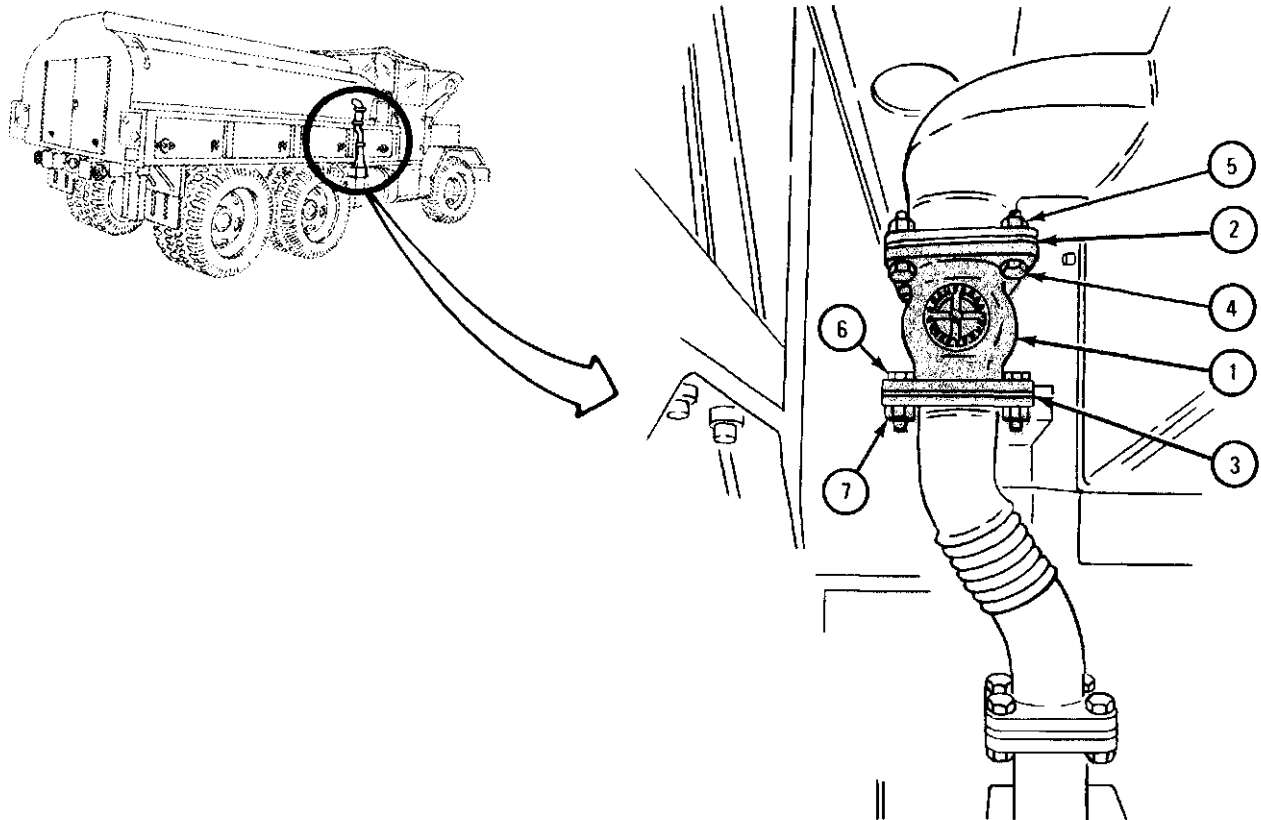

TA 080719

FRAME 9

- Soldiers 1. Put extension bypass pipe (1) with gasket (2) in place as shown, A and B and aline holes.
- Soldier A 2. Working behind cab, put in four capscrews (3) and screw on four locknuts (4).
3. Using 3/4-inch wrench, hold four locknuts (4). Tell soldier B when ready.
- Soldier B 4. Working under truck using 3/4-inch socket, two 10-inch extensions, 6-inch extension, and universal, tighten four capscrews (3).

GO TO FRAME 10

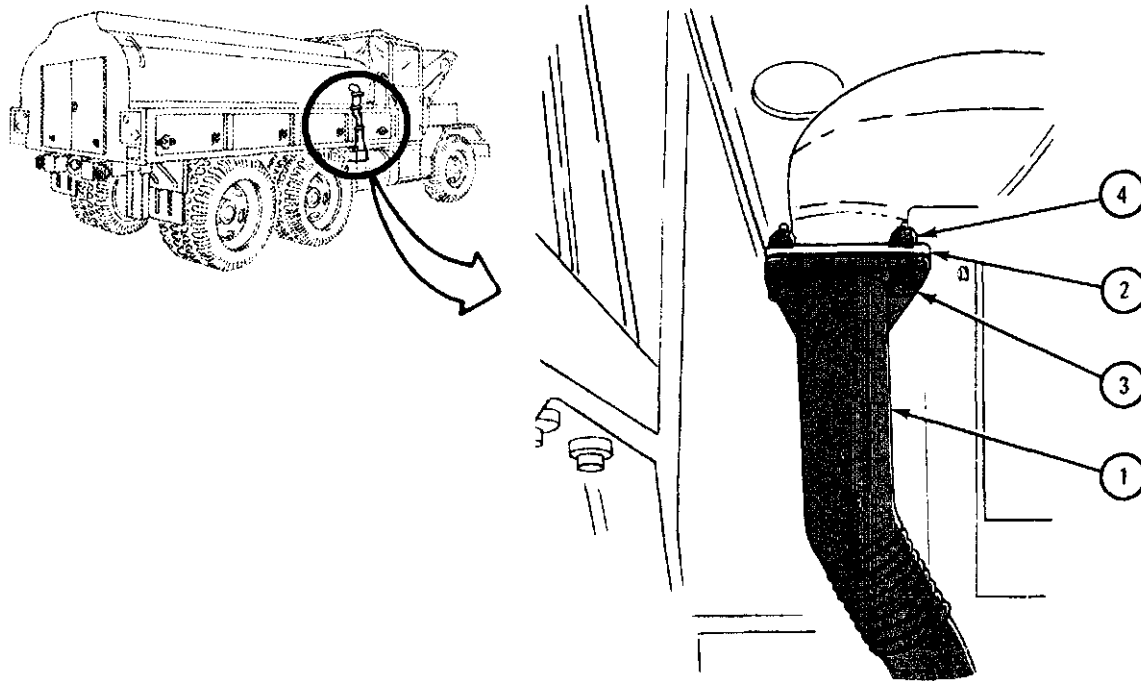

TA 089412

FRAME 10

1. Using 3/4-inch wrenches, tighten four capscrews (1) with locknuts (2).
GO TO FRAME 11

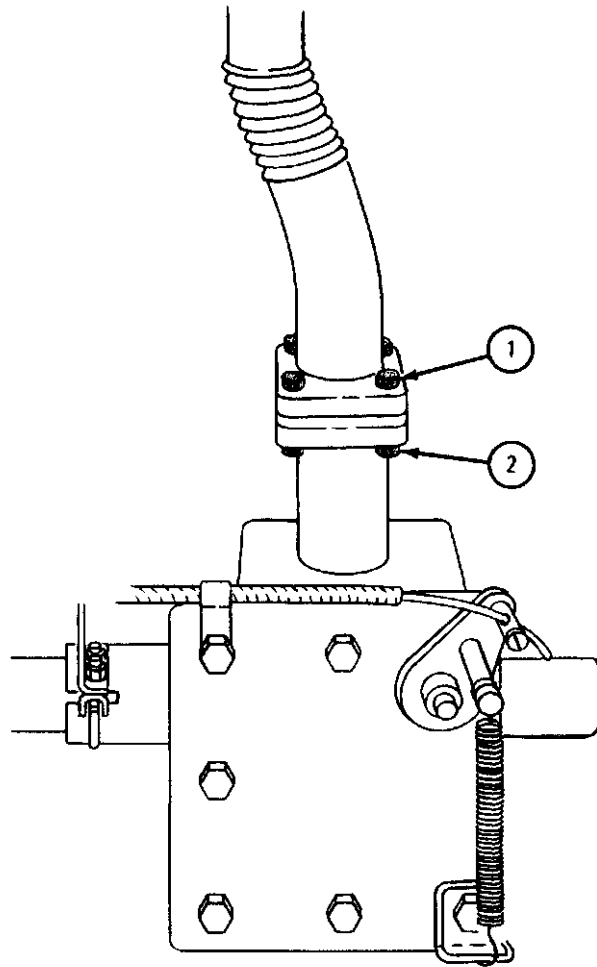

TA 080720

FRAME 11

1. Put large end of muffler (1) toward front of truck.
2. Spread open muffler loop clamp (2) and put it on muffler (1).
3. Push large end of muffler (2) over bypass valve (3) as far as it can go.
4. Align holes on muffler loop clamp (2) and bracket (4). Put in two capscrews (5) and screw on two locknuts (6).
5. Using 9/16-inch wrenches, tighten two capscrews (5) with locknuts (6).
6. Using 9/16-inch wrench, tighten two nuts (7) on clamp assembly (8).

GO TO FRAME 12

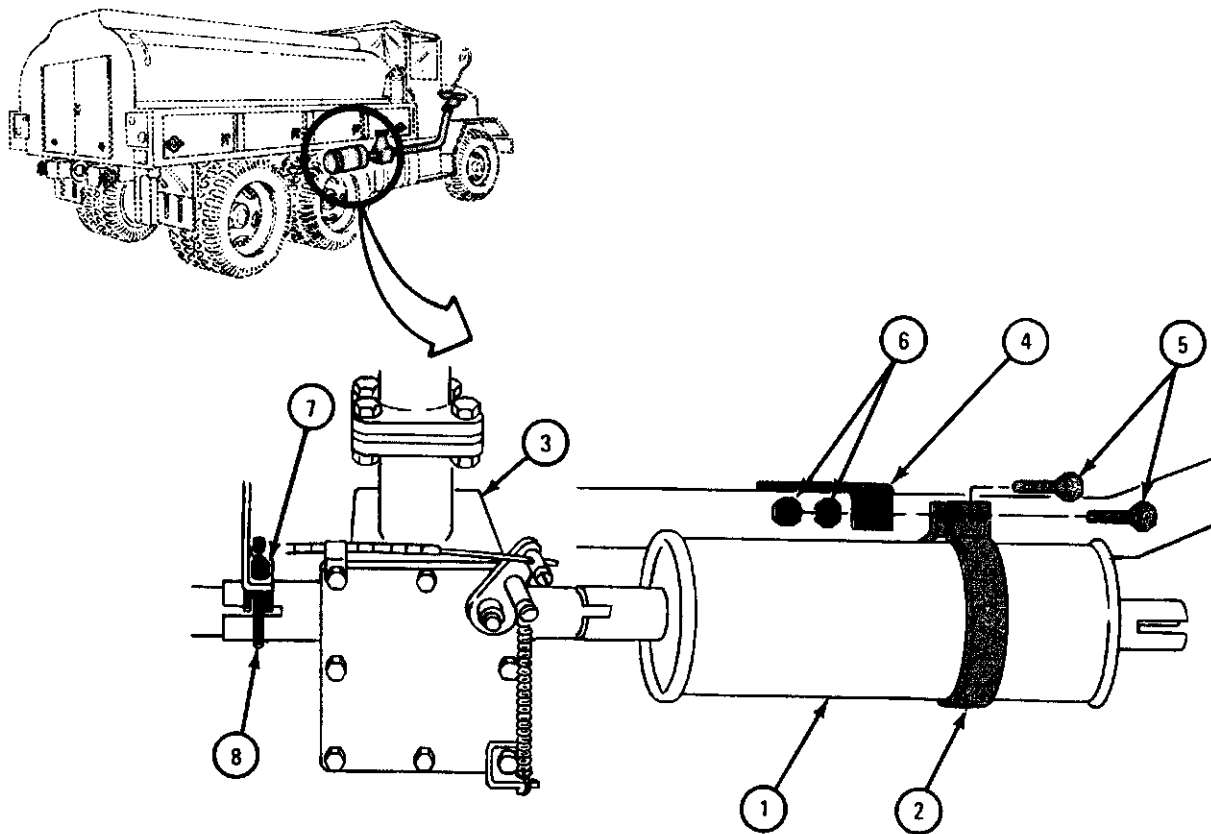

TA 080721

FRAME 12

1. Slide clamp (1) onto exhaust pipe (2).
2. Put exhaust pipe (2) into muffler (3). Exhaust pipe must pass under and outside of frame (4) as shown.

GO TO FRAME 13

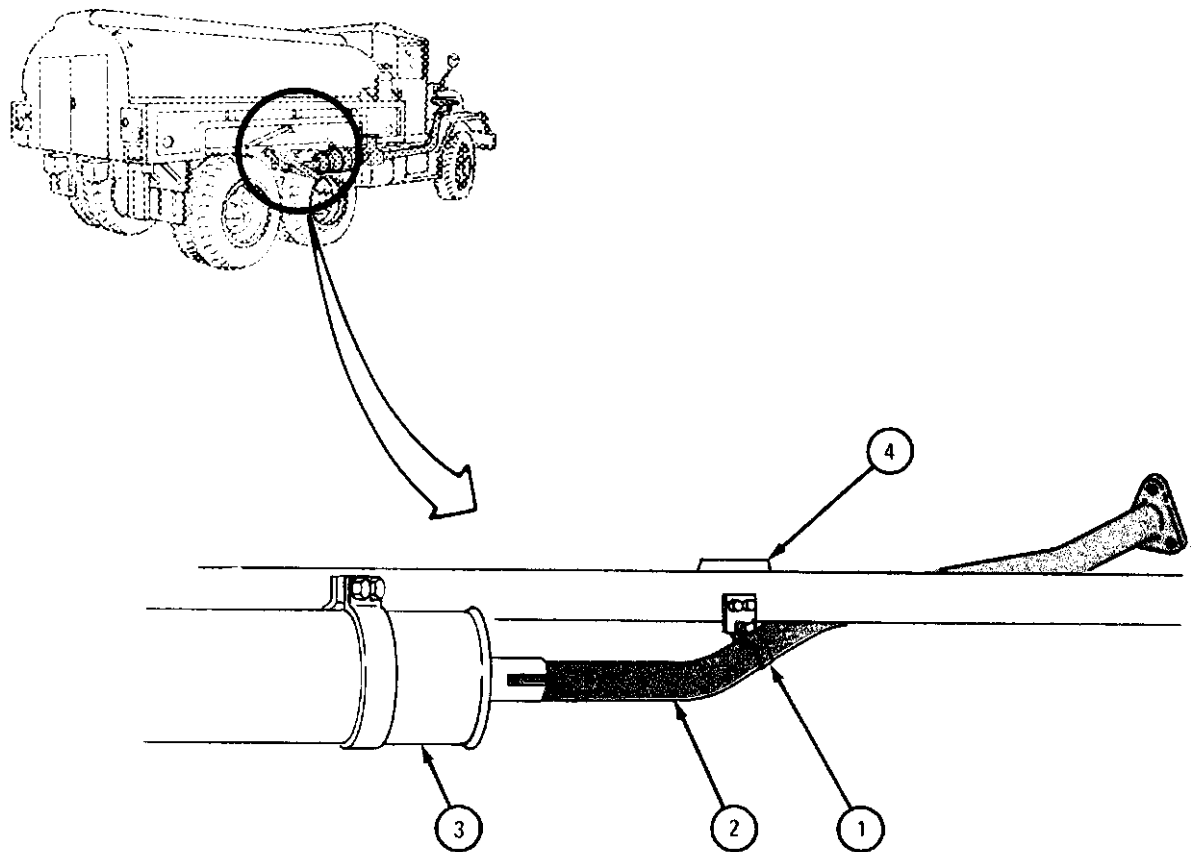

TA 080722

FRAME 13

1. Working from side of truck, aline hole in clamp (1) with hole in bracket (2).
 2. Put in capscrew (3) and screw on locknut (4).
 3. Turn exhaust pipe (5) as needed to make it clear tire (6) by about 1 inch.
 4. Using 9/16-inch wrenches, tighten capscrew (3) and locknut (4).
- GO TO FRAME 14.

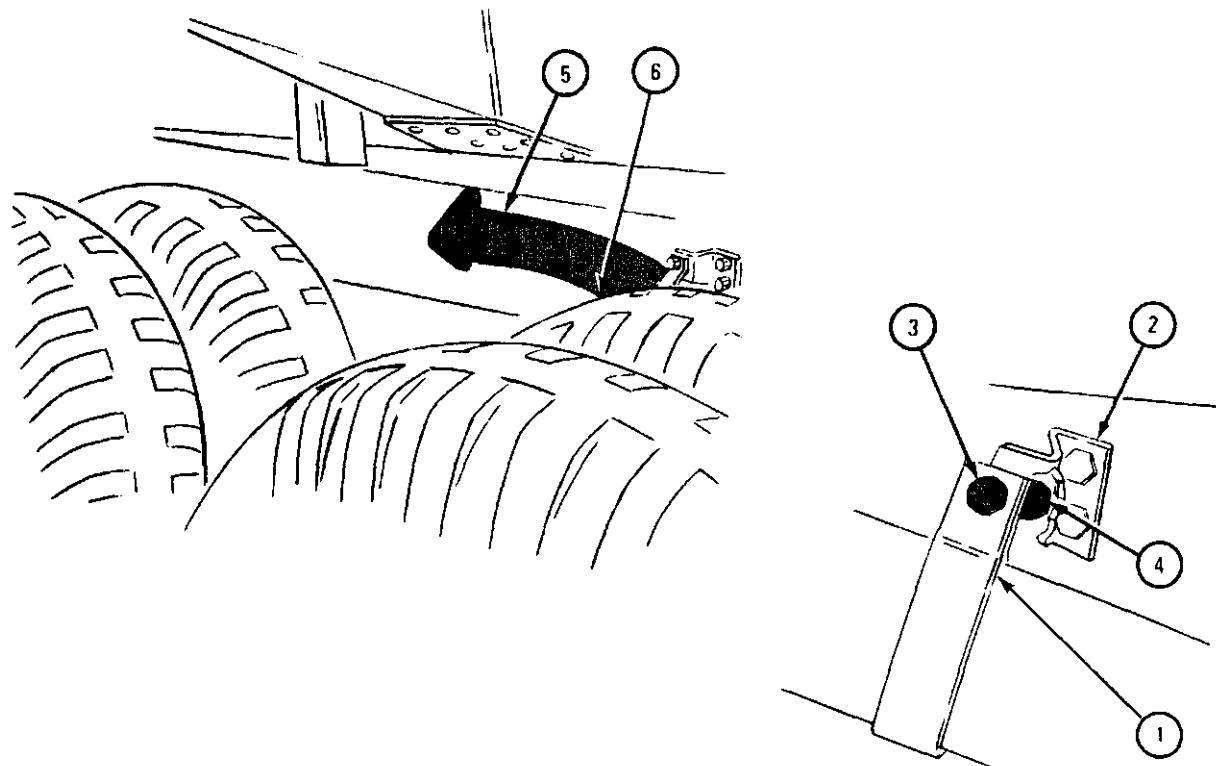

TA 080723

FRAME 14

1. Put U-bolt (1) and clamp (2) on front of muffler (3). Using 9/16-inch wrench, screw on and tighten two washers (4) and nuts (5).
2. Put U-bolt (6) and clamp (7) on back of muffler (3). Using 1/2-inch wrench, screw on and tighten two washers (8) with nuts (9).

GO TO FRAME 15

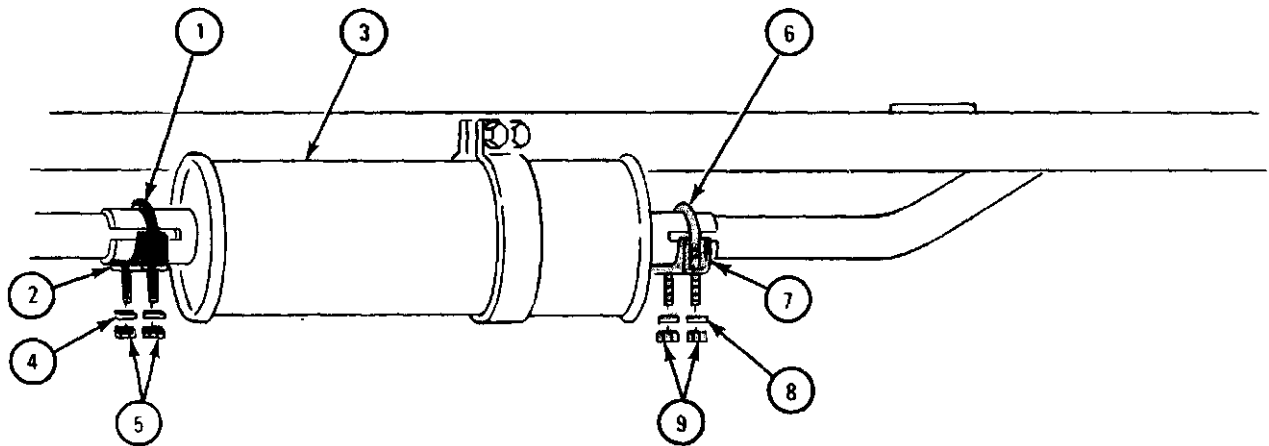

TA 080724

FRAME 15

1. Put exhaust pipe extension pipe (1) and gasket (2) on exhaust pipe (3).
2. Aline holes and put in three capscrews (4) with locknuts (5).
3. Using 9/16-inch wrenches, tighten three capscrews (4) and three locknuts (5).

NOTE

Follow-on Maintenance Action Required:
Replace air cleaner. Refer to para 4-3.

END OF TASK

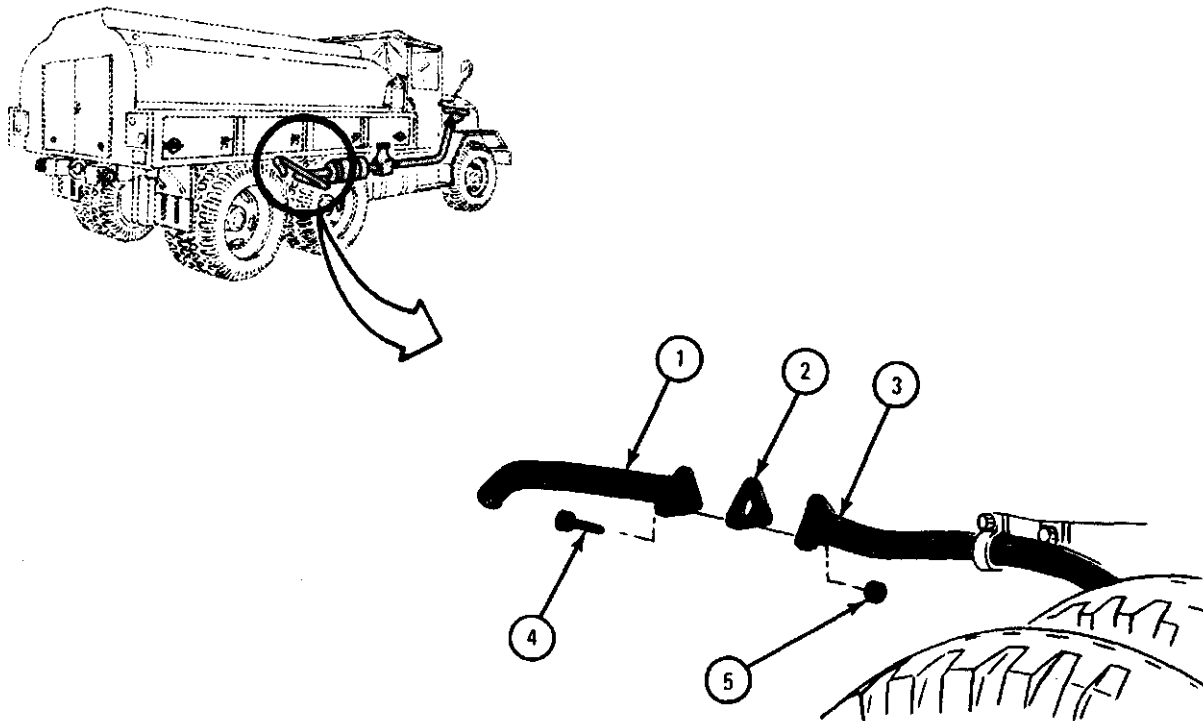

TA 080786

5-5. EXHAUST SYSTEM (HORIZONTAL) REMOVAL AND REPLACEMENT
(TRUCKS WITH ENGINE LD 427).

TOOLS : 9/16-inch wrench (2)
9/16-inch socket wrench
2-inch extension

SUPPLIES : Exhaust pipe front gasket
Exhaust pipe extension gasket

PERSONNEL : One

EQUIPMENT CONDITION : Truck parked, engine off and cool, handbrake set.

a. Preliminary Procedures.

(1) Remove air cleaner. Refer to para 4-3.

(2) Disconnect battery ground cable. Refer to para 7-58.

b. Removal.

WARNING

Do not work on hot exhaust systems.
Personnel can be badly burned.

FRAME 1

1. Using 9/16-inch wrenches, unscrew and take off three locknuts (1) and three capscrews (2).
2. Take off exhaust pipe extension pipe (3) and gasket (4). Throw away gasket.

GO TO FRAME 2

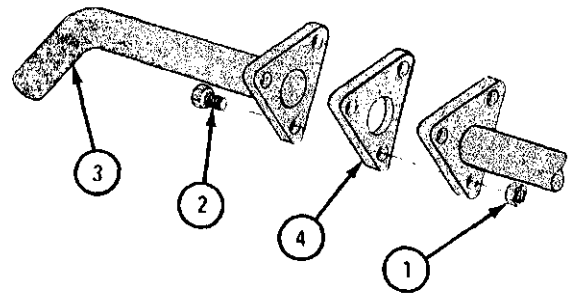
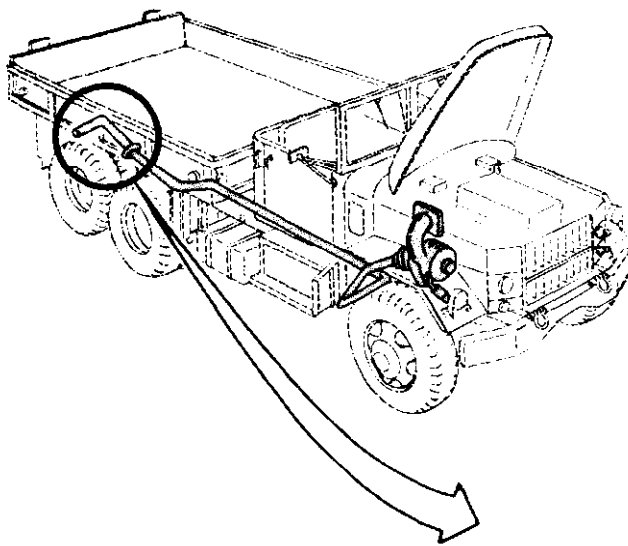

TA 080738

FRAME 2

1. Using 9/16-inch wrenches, unscrew and take off capscrew and locknut (1).
2. Spread open and takeoff clamp (2).

GO TO FRAME 3

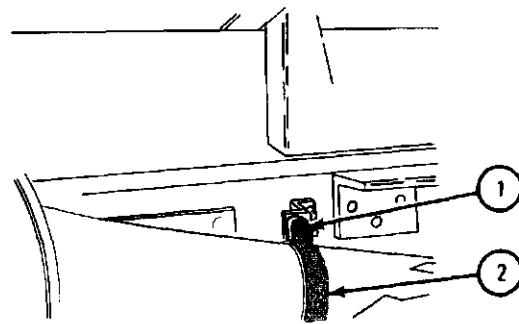
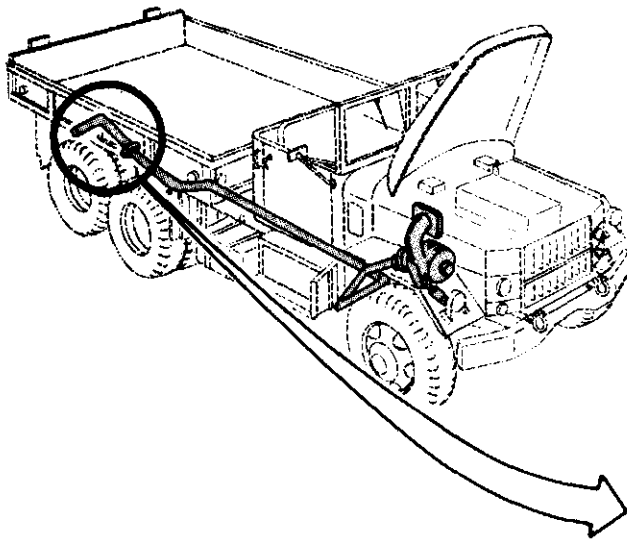

TA 080739

FRAME 3

1. Using 9/16-inch wrench, unscrew and take off two nuts and lockwashers (1), clamp bracket (2), and U-bolt (3).
2. Slide rear pipe (4) out of front pipe (5).

GO TO FRAME 4

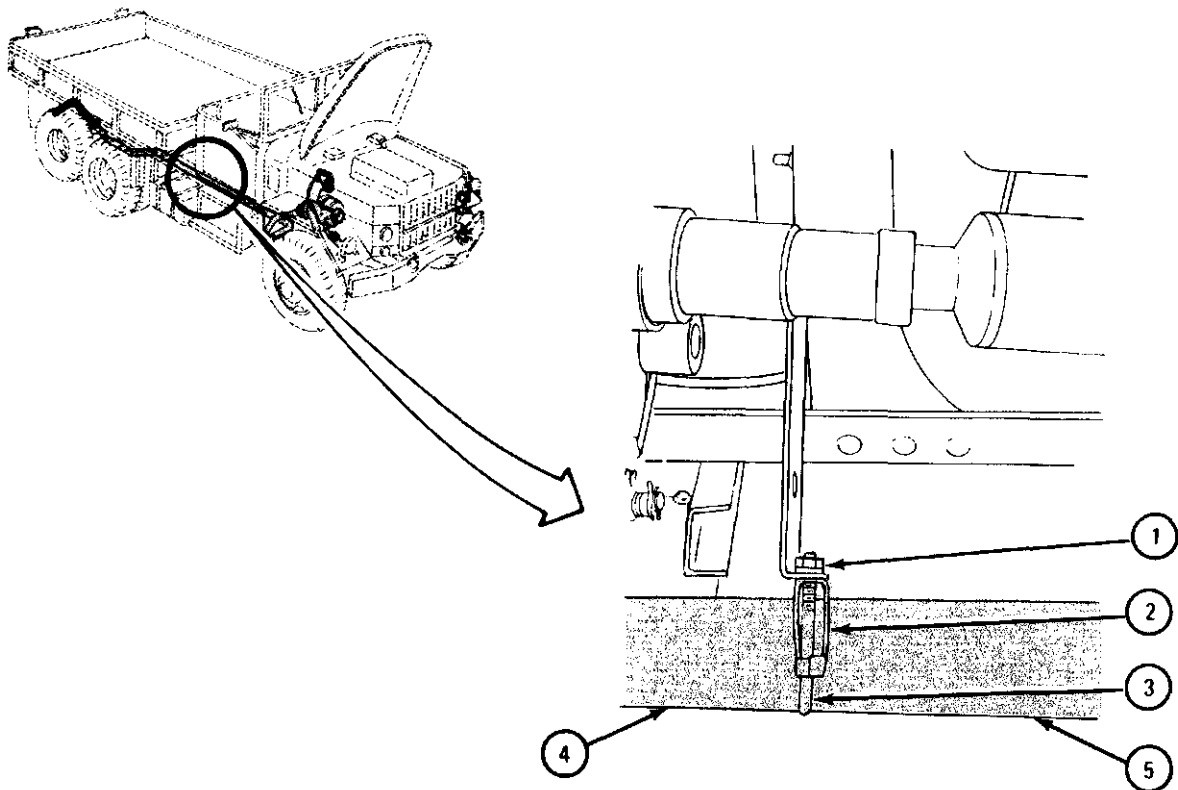

TA 080740

FRAME 4

1. Using 9/16-inch wrench, unscrew and takeout capscrew (1).
2. Pull pebble shield (2) away from exhaust pipe (3) so that pipe can be taken out.

GO TO FRAME 5

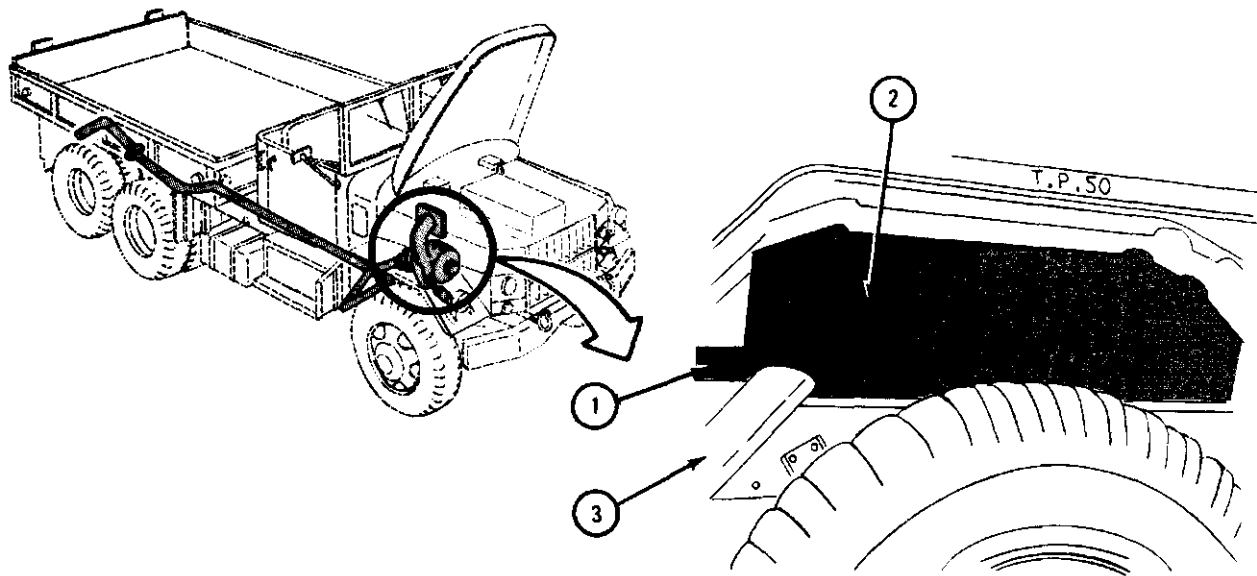

TA 080741

FRAME 5

1. Using 9/16-inch wrenches, unscrew and take off three capscrews (1) and locknuts (2).
2. Take off exhaust pipe (3) and gasket (4). Throw away gasket.

END OF TASK

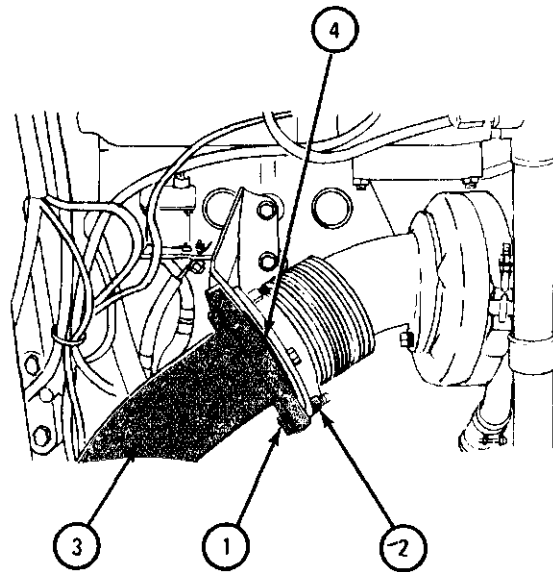
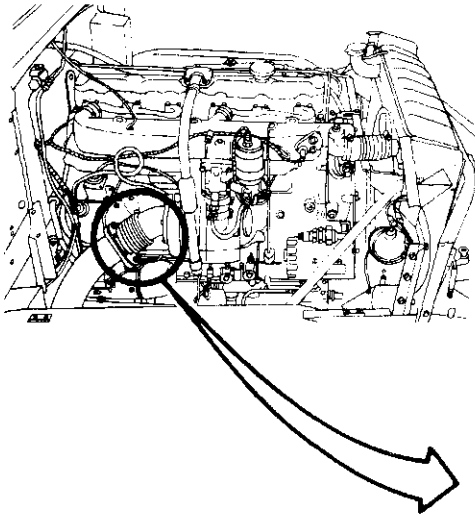

TA 080742

c. Replacement.

FRAME 1

1. From under right front fender (1), put in exhaust pipe (2) as shown.
 2. Put pebble shield (3) over exhaust pipe (2).
 3. Using 9/16-inch wrench, screw in and tighten capscrew (4).
- GO TO FRAME 2

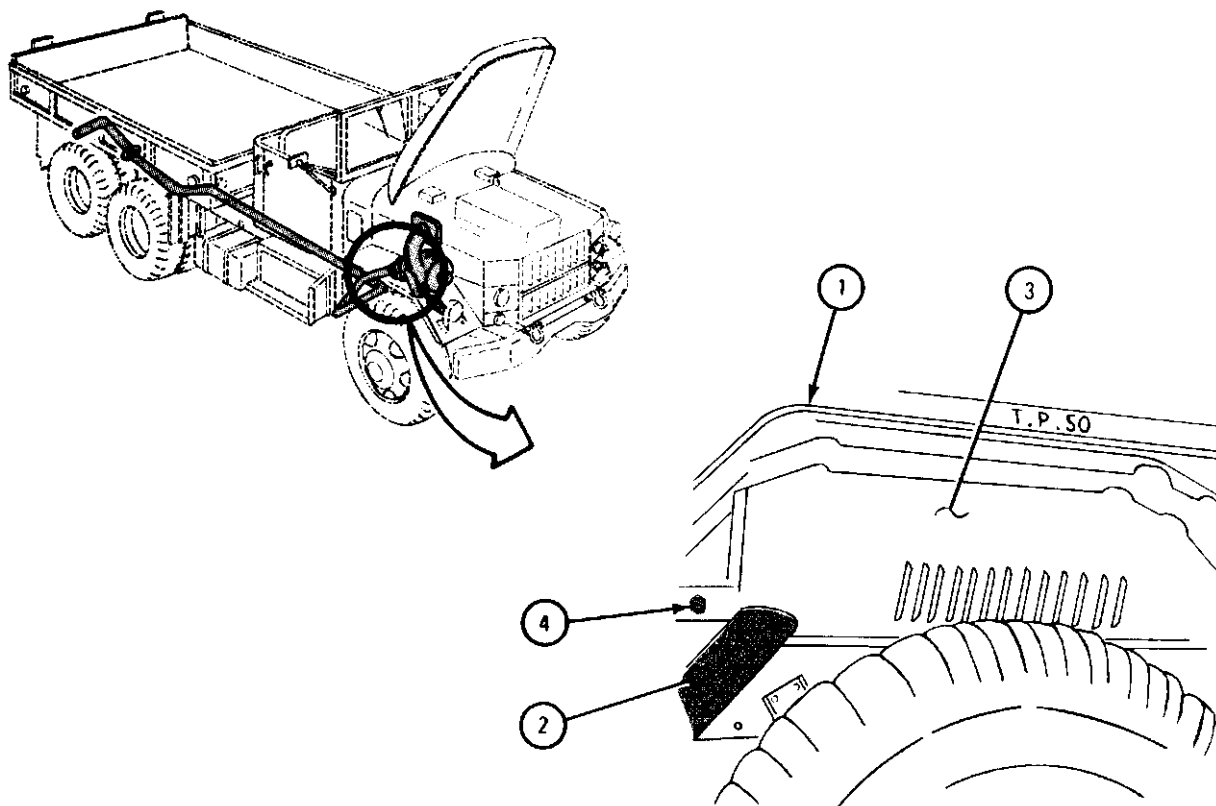

TA 080743

FRAME 2

1. Put exhaust pipe (1) and exhaust pipe front gasket (2) up to elbow (3) and bracket (4), alining holes.
2. Using 9/16-inch wrenches, screw in and tighten three capscrews (5) and locknuts (6).

GO TO FRAME 3

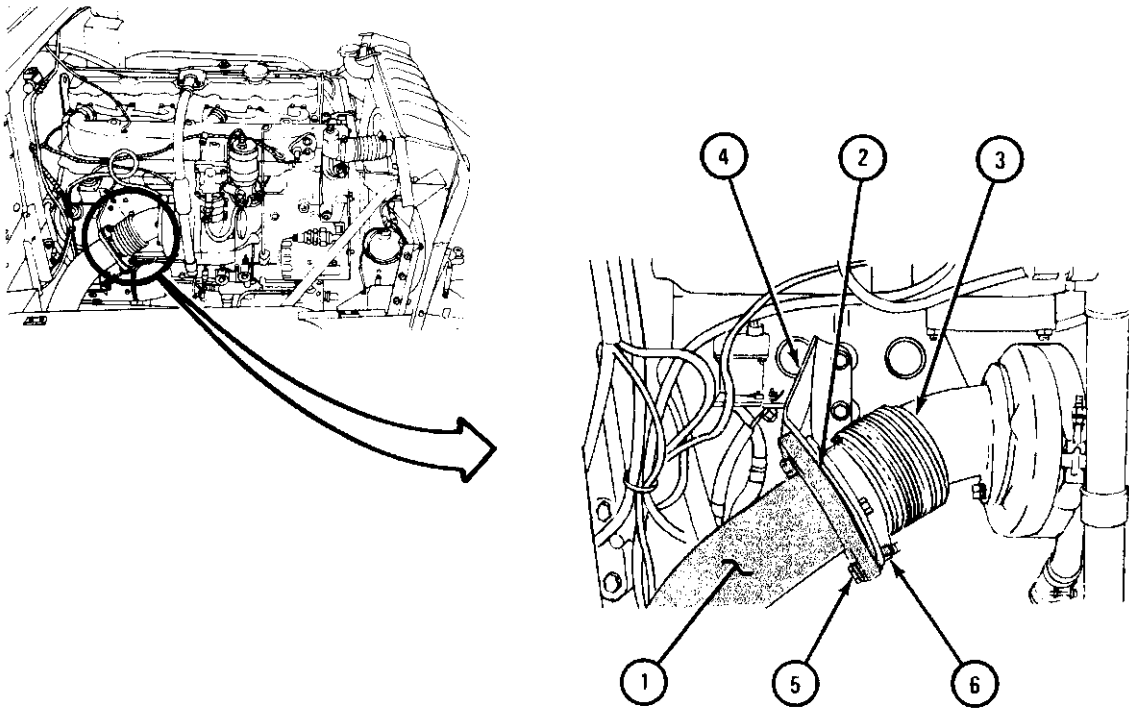

TA 080744

FRAME 3

1. Put clamp bracket (1) in between exhaust pipe (2) and exhaust bracket (3) as shown.
2. Put U-bolt (4) over exhaust pipe (2) and through clamp bracket (1) and exhaust bracket (3). Put slotted end of rear pipe (5) over exhaust pipe (2).
3. Using 9/16-inch wrench, tighten two nuts (6) and lockwashers (7).

GO TO FRAME 4

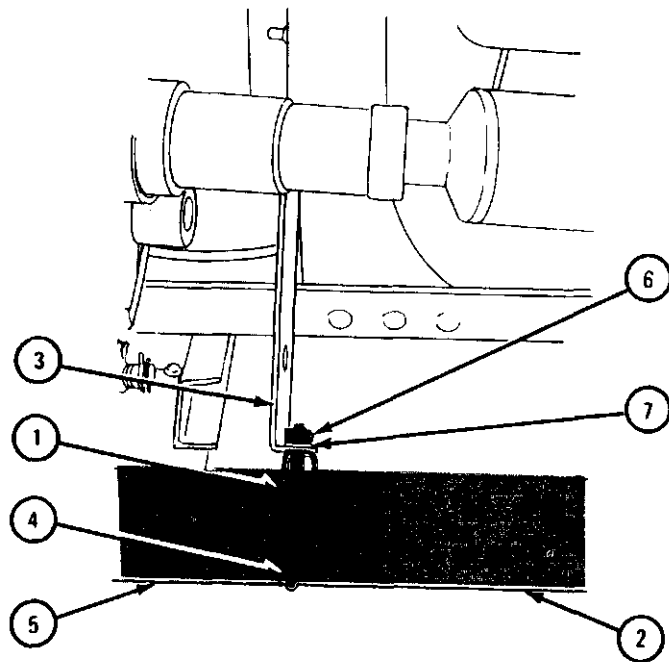
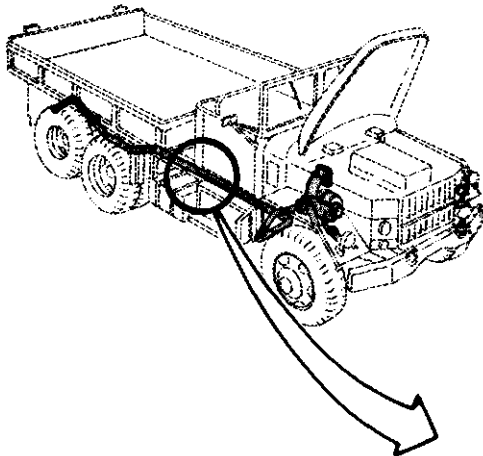

TA 080745

FRAME 4

1. Put clamp (1) over exhaust pipe (2), alining holes in clamp and exhaust bracket (3) .
 2. Using 9/16-inch wrenches , screw in and tighten capscrew and locknut (4).
- GO TO FRAME 5

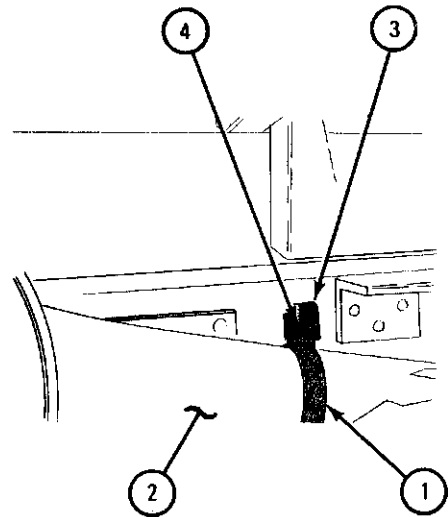
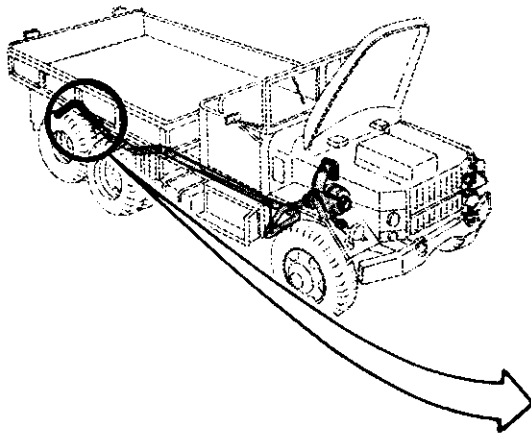

TA 080746

FRAME 5

1. Put tailpipe extension (1) with exhaust pipe extension gasket (2) on exhaust pipe (3).
2. Aline holes and screw in three capscrews (4) with three locknuts (5).
3. Using 9/16-inch wrenches, tighten three capscrews (4) and three locknuts (5).

NOTE

Follow-on Maintenance Action Required:

1. Replace air cleaner. Refer to para 4-3.
2. Reconnect battery ground cable. Refer to para 7-58.

END OF TASK

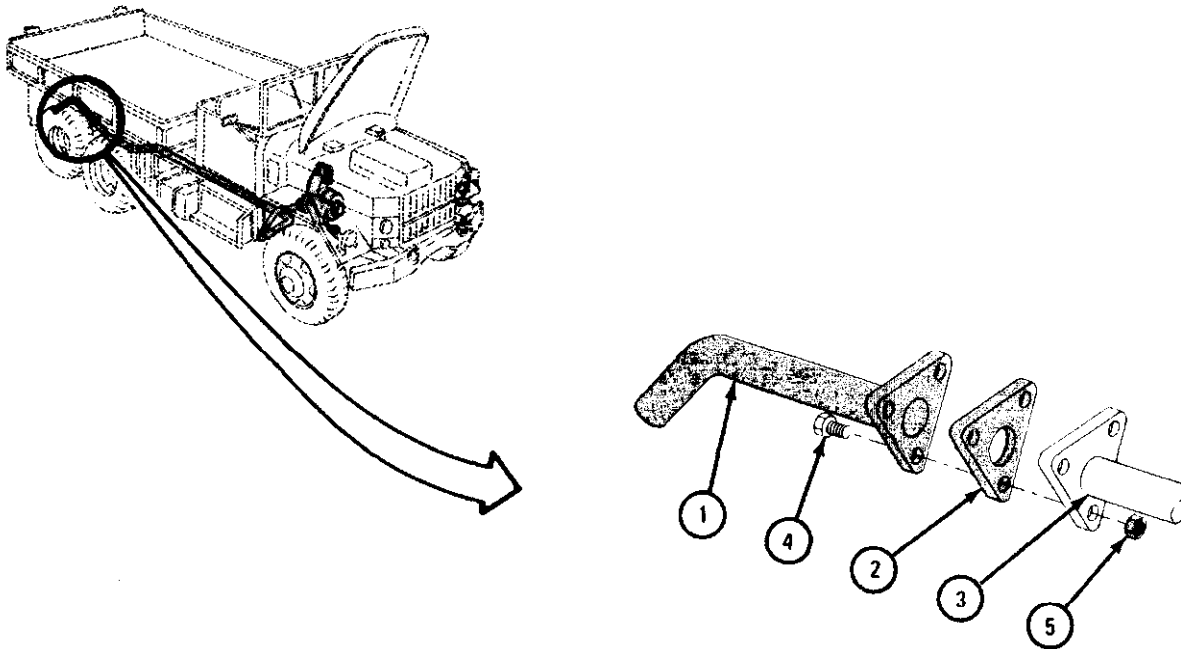

TA 080747

5-6. EXHAUST SYSTEM (VERTICAL STACK) REMOVAL AND REPLACEMENT
(TRUCKS WITH ENGINES LD 465-1, LD 465-1C, AND LDT 465-1C EXCEPT
TRUCKS M50A2 AND M50A3).

TOOLS : 7/16-inch open end wrench 1/2-inch open end wrench
 7/16-inch socket wrench 1/2-inch socket wrench
 Slip joint pliers 9/16-inch open end wrench
 Flat-tip screwdriver (2) 9/16-inch socket wrench

SUPPLIES : None

PERSONNEL: One

EQUIPMENT CONDITION : Truck parked, engine off, handbrake set.

- a. Preliminary Procedure. Remove air cleaner. Refer to para 4-3.
- b. Removal.

FRAME 1

1. Using 7/16-inch wrenches, unscrew and take out locknut (1) and bolt (2) .
2. Using screwdriver and pliers, spread coupling (3) and slide coupling a few inches up pipe (4) .
3. Throw gasket (5) away.

GO TO FRAME 2

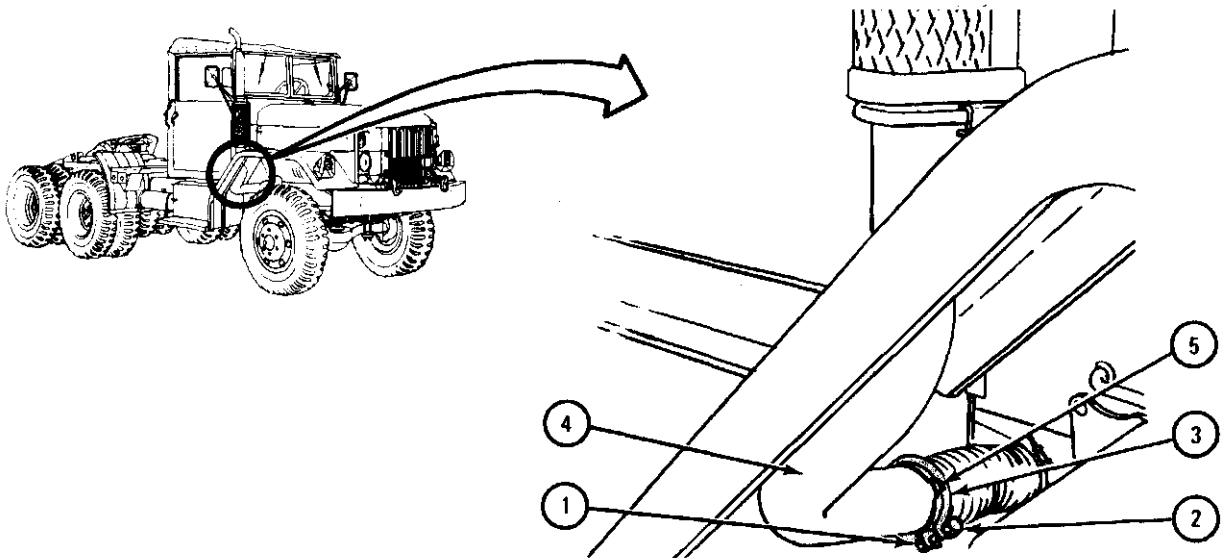

TA 047228

FRAME 2

1. Using 7/16-inch wrench and 1/2-inch wrench, unscrew and take off two locknuts (1) and two bolts (2) out of fender shield (3).
2. If needed, use screwdriver to pry fender shield (3) away from top of fender (4).
3. If needed, use screwdriver to pry sand shield (5) away from bottom of fender (4).

GO TO FRAME 3

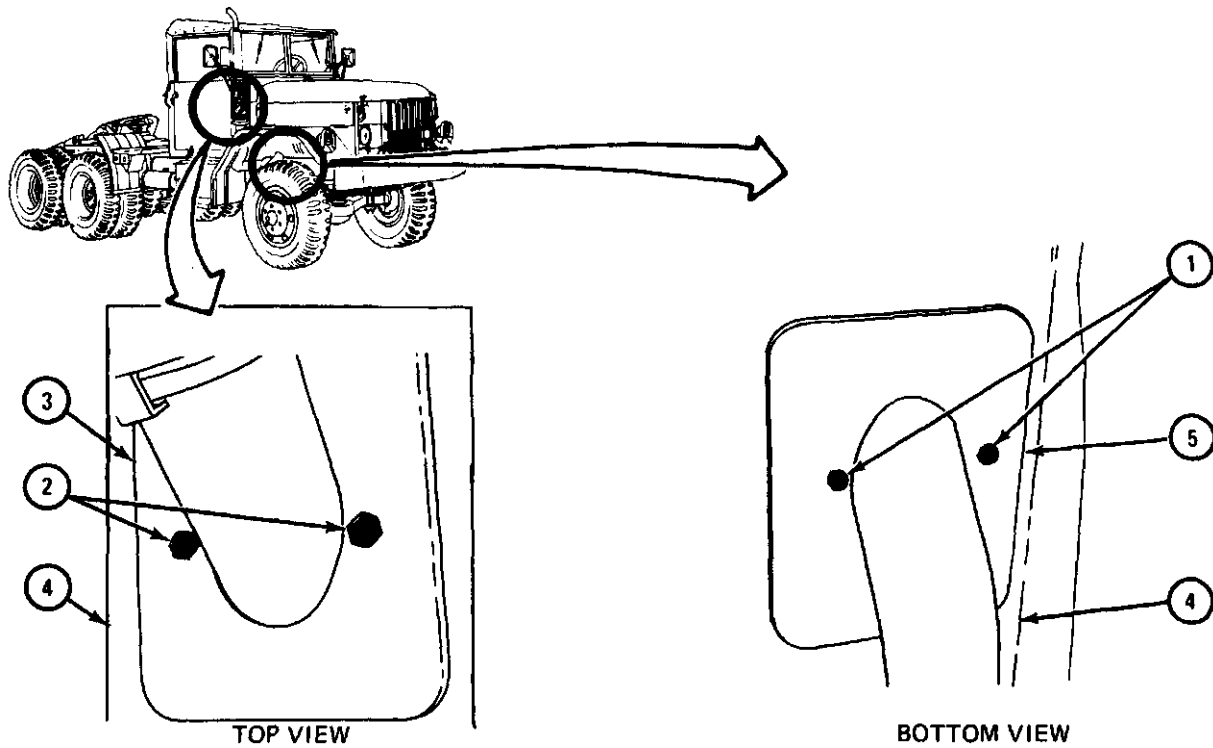

TA 047229

FRAME 3

1. Using 1/2-inch wrench, unscrew two locknuts (1) and take off U-bolt and bracket (2).

NOTE

Upper stack pipe (3) may be stuck to lower stack pipe (4). If needed, use hammer and pinch bar to loosen stack pipe.

2. Pull upper stack pipe (3) off lower stack pipe (4).

NOTE

Hold lower stack pipe (4) when taking off locknuts (5) and U-bolt and bracket (6).

3. Using 9/16-inch wrench, unscrew two locknuts (5) and take off U-bolt and bracket (6). Slide shield assembly (7) up and off lower stack pipe (4).
4. Take lower stack pipe (4) out by turning as necessary and lowering pipe through cutout in fender.

GO TO FRAME 4

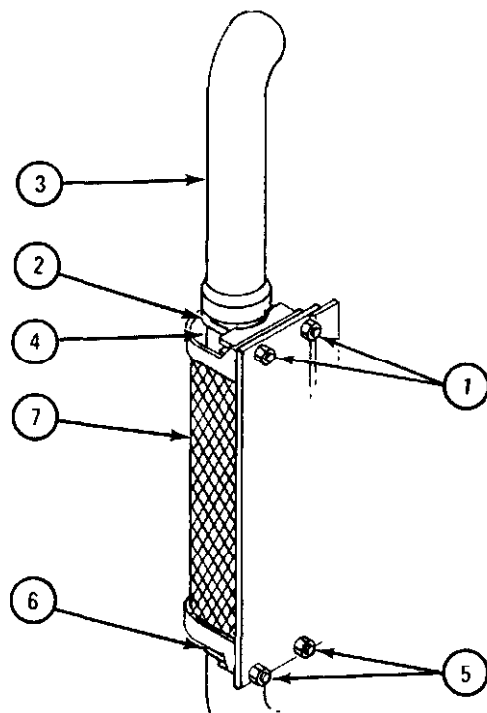

TA 047230

FRAME 4

1. Using 7/16-inch wrenches, unscrew and takeout locknut (1) and bolt (2) from coupling (3).
2. Using screwdriver and pliers, spread coupling (3) and take off exhaust flex line (4).
3. Throw gasket (5) away.

GO TO FRAME 5

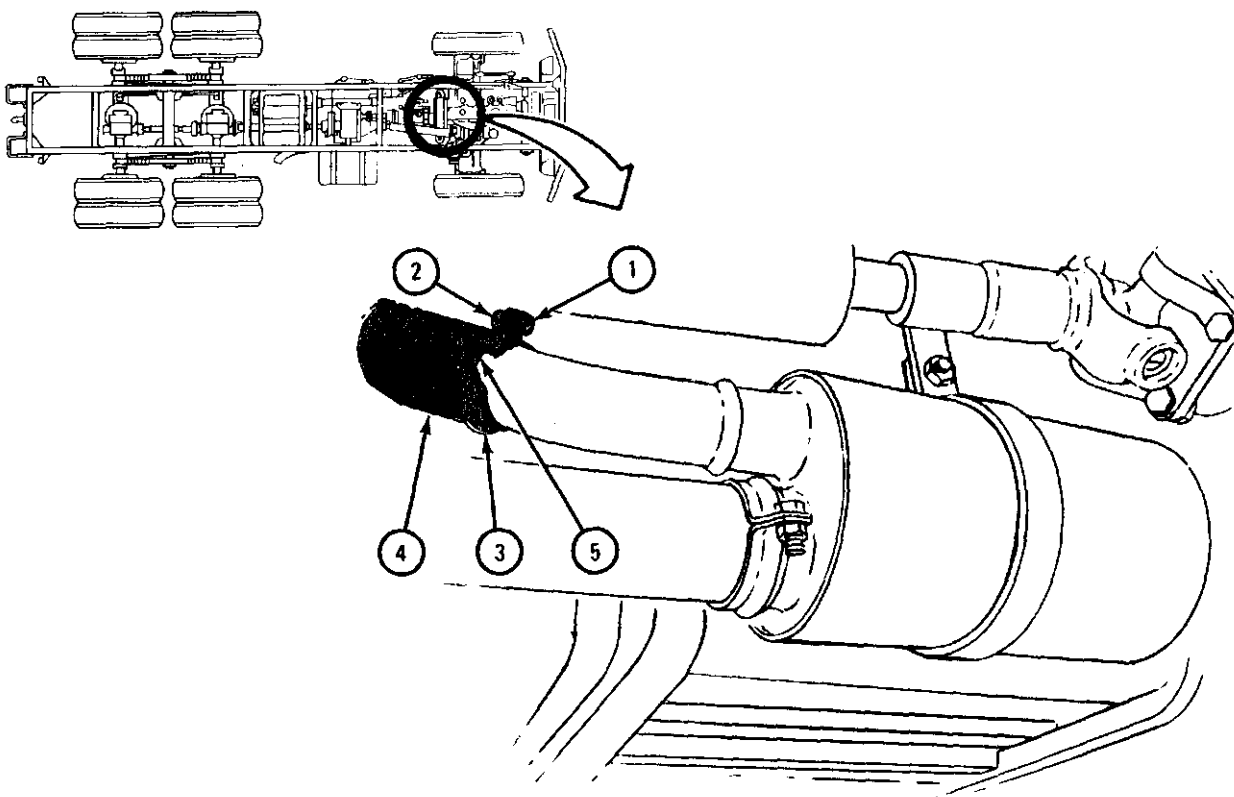

TA 047231

FRAME 5

1. Using 1/2-inch wrenches, unscrew and take out locknut (1) and bolt (2) from coupling (3) .
2. Using screwdriver and pliers, spread coupling (3) and slide coupling forward and away from muffler (4) . Throw gasket (5) away.

GO TO FRAME 6

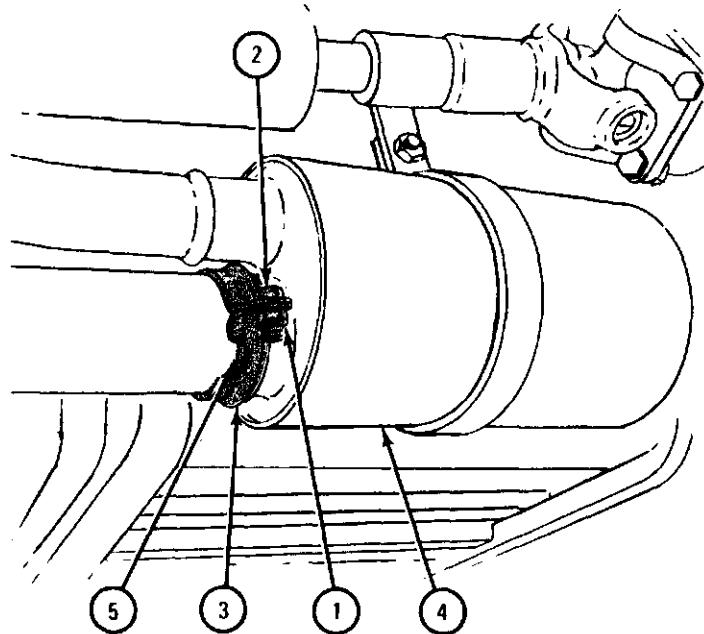

TA 047232

FRAME 6

1. Using 9/16-inch wrenches, unscrew and take off two locknuts (1) from two bolts (2).

CAUTION

Hold muffler (3) up with one hand when taking off bolts (2). Failure to do this may cause damage to equipment.

2. Take off two flat washers (4) and two bolts (2).
3. Take muffler (3) off two resilient mounts (5).

GO TO FRAME 7

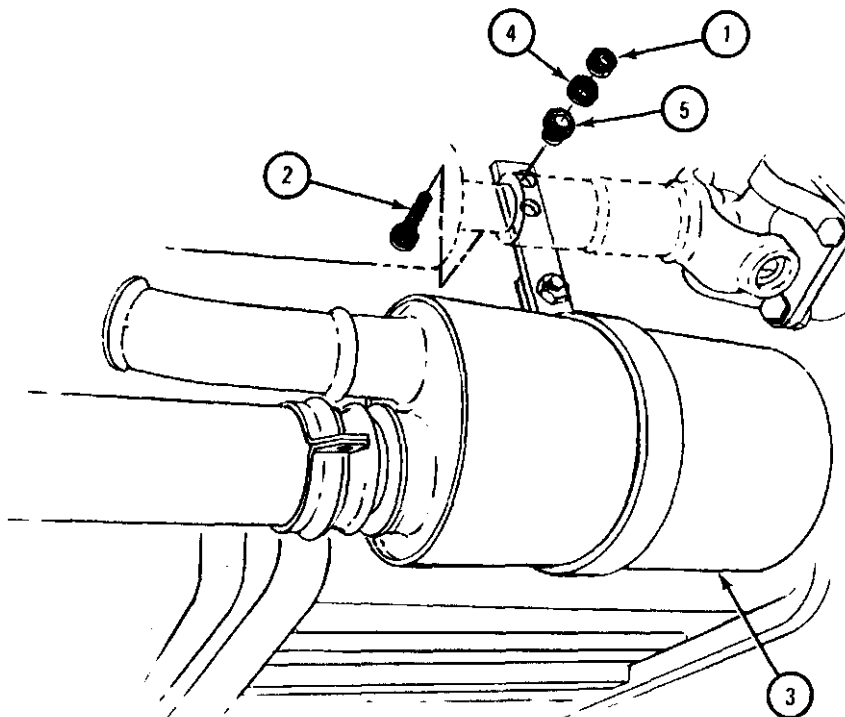

TA 047233

FRAME 7

1. Using 9/16-inch wrenches, unscrew and take off locknut (1) and bolt (2) from loop clamp (3) .
 2. Using large screwdriver, spread loop clamp (3) and slide off of muffler (4).
- GO TO FRAME 8

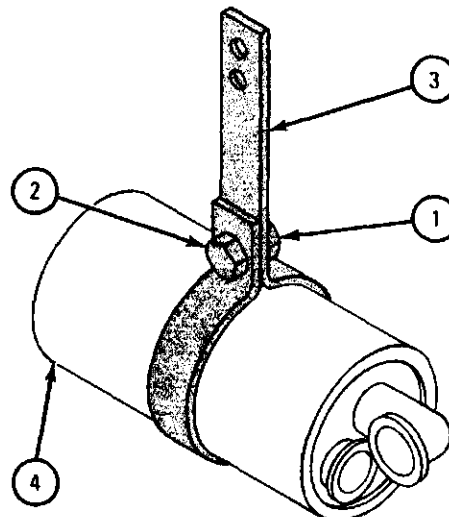

TA 047234

FRAME 8

1. Using 9/16-inch wrenches, unscrew three locknuts (1) from three bolts (2). Hold exhaust pipe (3) and take out bolts.
2. Take out exhaust pipe (3). Throw gasket (4) away.

GO TO FRAME 9

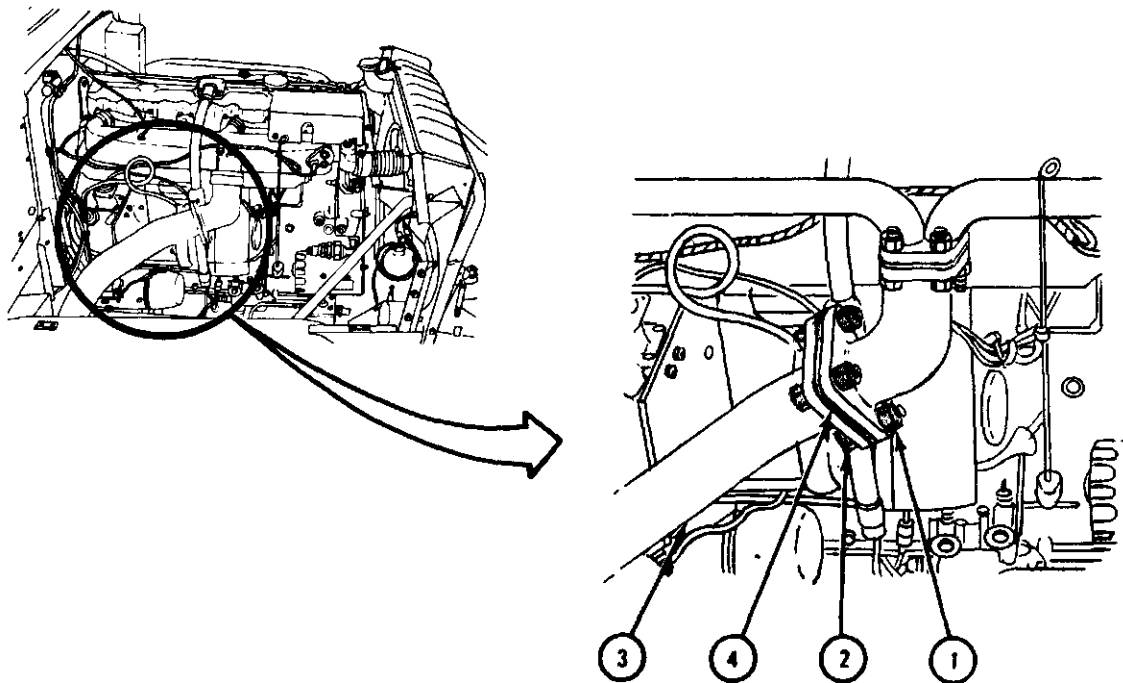

TA 047235

FRAME 9

1. Using 9/16-inch wrenches, unscrew and take off two locknuts (1) and two bolts (2). Hold exhaust elbow (3) and unscrew two locknuts (4) from two studs (5) using 9/16-inch wrench.
2. Take elbow (3) off manifold (6). Throw gasket (7) away.

END OF TASK

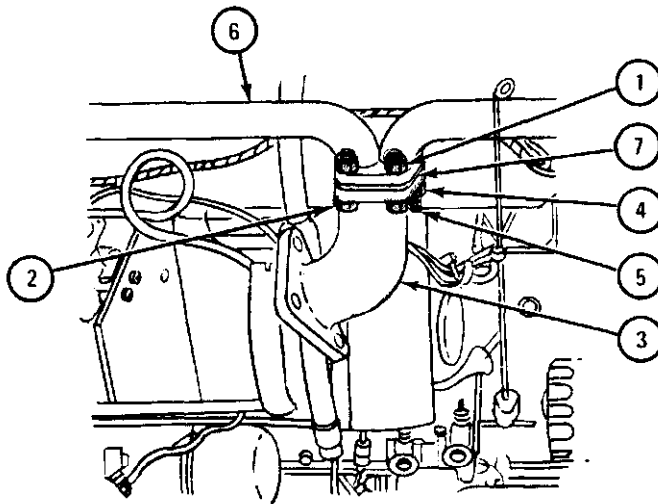

TA 047236

c. Replacement.

FRAME 1

1. Put exhaust elbow (1) and new gasket (2) over two studs on flange (3).
2. Screw two locknuts (4) on studs at inside of flange (3).
3. Put two bolts (5) through exhaust elbow (1) and flange (3). Screw on two locknuts (6).
4. Using 9/16-inch wrench, evenly tighten locknuts (6) on bolts (5) and locknuts (4) on studs of flange (3).

GO TO FRAME 2

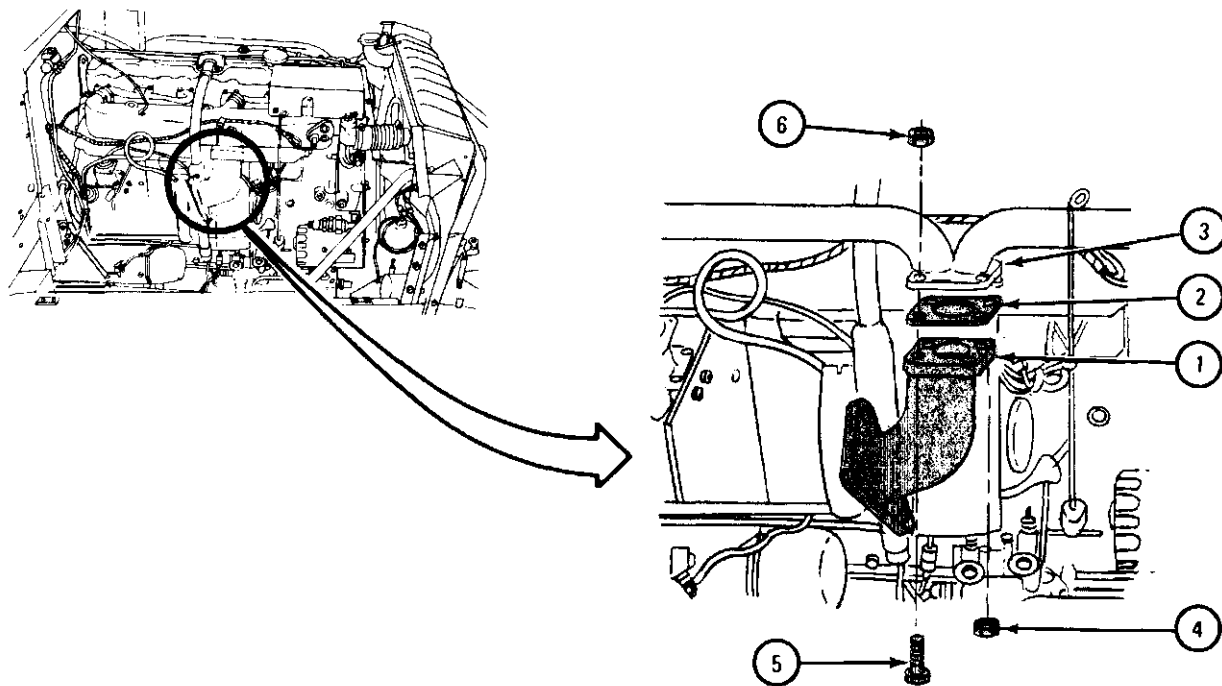

TA 047237

FRAME 2

1. Put exhaust pipe (1) into engine compartment as shown.
2. Join flange of exhaust pipe (1) to exhaust elbow flange (2). Use three bolts (3) , new gasket (4) and three locknuts (5) as shown. Screw on locknuts but do not tighten at this time.

GO TO FRAME 3

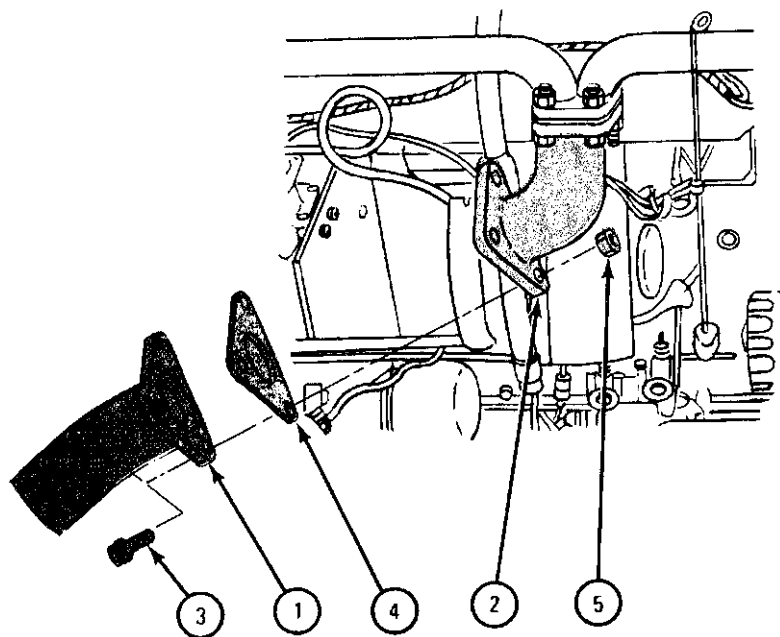

TA 047238

FRAME 3

1. Put loop clamp (1) on muffler (2) as shown. Put bolt (3) through loop clamp and screw on locknut (4) finger tight.
2. Set loop clamp (1) so larger intake opening (5) is directly below outlet (6) as shown. Both must be in line with loop clamp.
3. Using 9/16-inch wrenches, tighten locknut (4).

GO TO FRAME 4

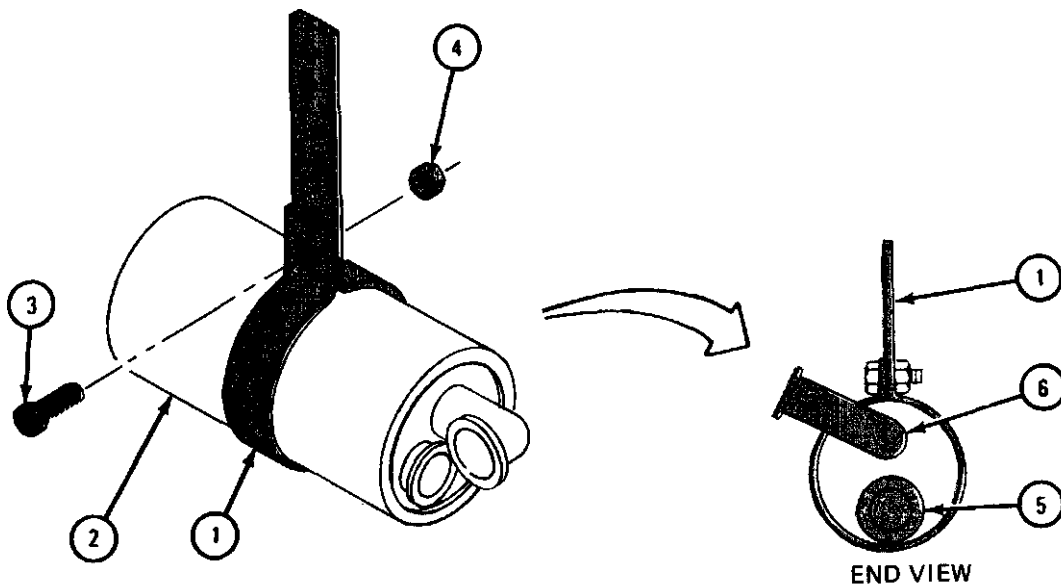

TA 047239

FRAME 4

1. Put two resilient mounts (1) through holes in loop clamp (2) as shown.
2. Place muffler (3) so holes in loop clamp (2) aline with holes in bracket (4). Put two bolts (5) through bracket and loop clamp as shown.
3. Put two flat washers (6) on bolts (5) and screw on two locknuts (7). Using 1/2-inch wrenches, tighten locknuts.

GO TO FRAME 5

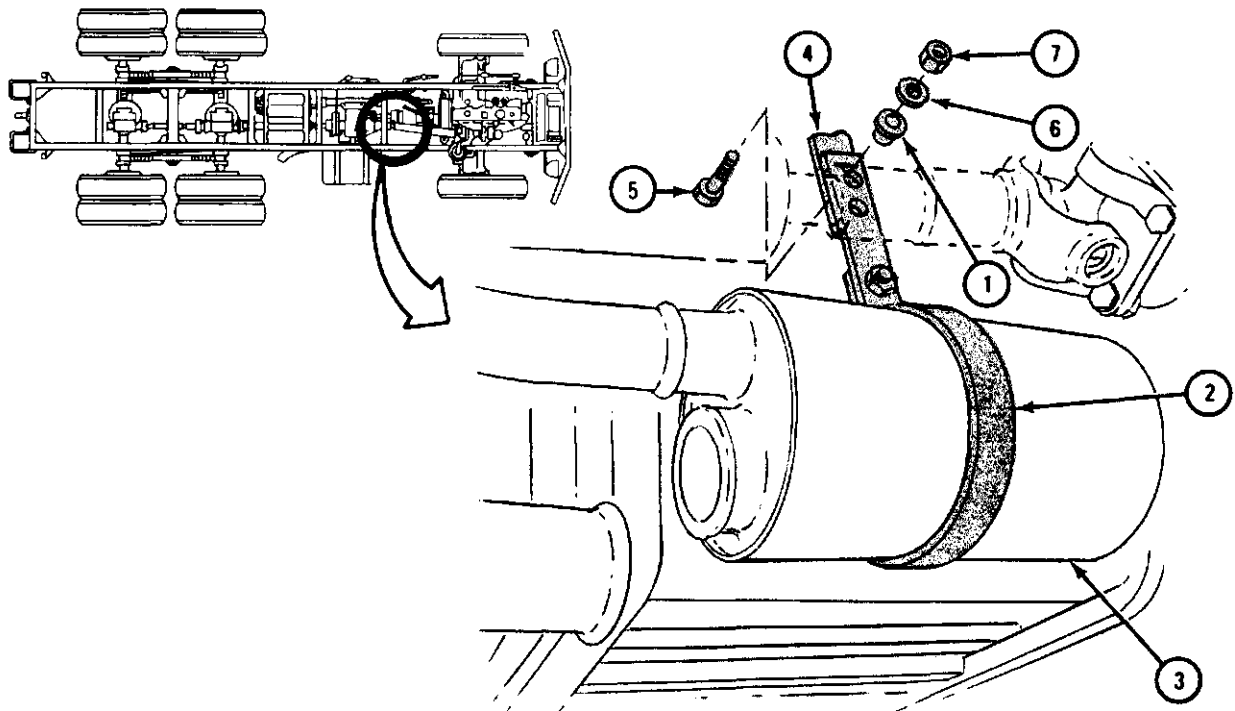

TA 047240

FRAME 5

1. Put gasket (1) against flange of exhaust pipe (2). Spread coupling (3) and put over flange and gasket.
2. Raise exhaust pipe (2) and aline with muffler intake fitting (4).
3. Join exhaust pipe (2) to intake fitting (4) using coupling (3).

NOTE

Coupling must hold both flanges. Make sure gasket (1) stays in coupling.

4. Put bolt (5) through coupling (3) and screw on locknut (6). Using 7/16-inch wrenches, tighten locknut.

GO TO FRAME 6

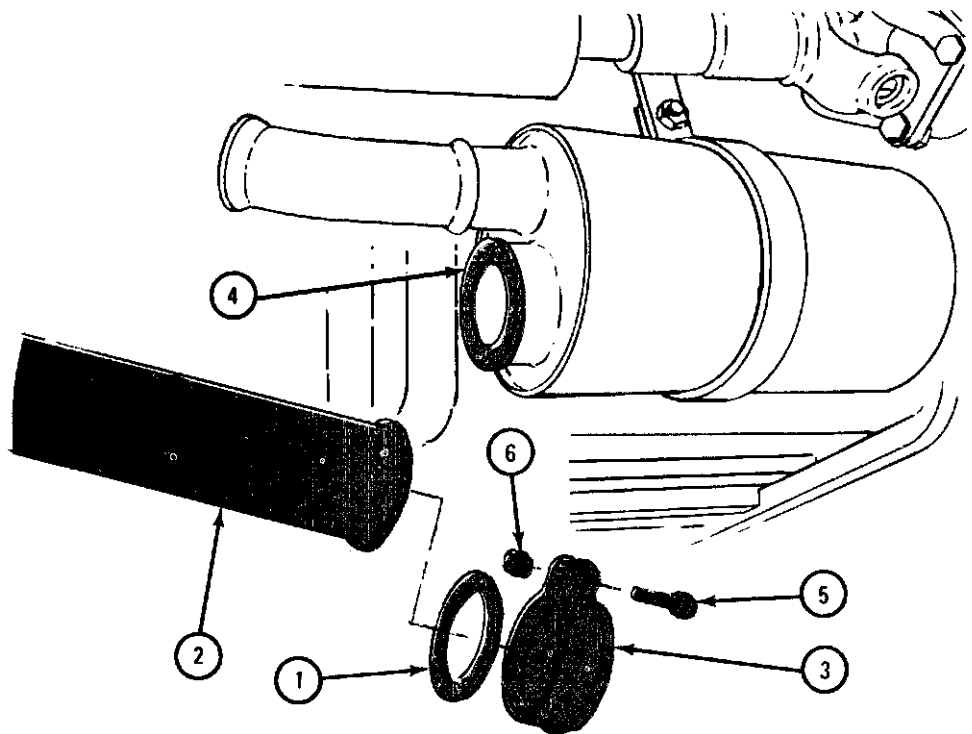

TA 047241

FRAME 6

1. Join exhaust flex line (1) to elbow (2) using gasket (3) and coupling (4) as shown.

NOTE

Coupling must hold both flanges. Make sure gasket (3) is between flange of exhaust flex line (1) and flange of elbow (2).

2. Put bolt (5) through coupling (4) and screw on locknut (6). Using 7/16-inch wrenches, tighten locknut.

GO TO FRAME 7

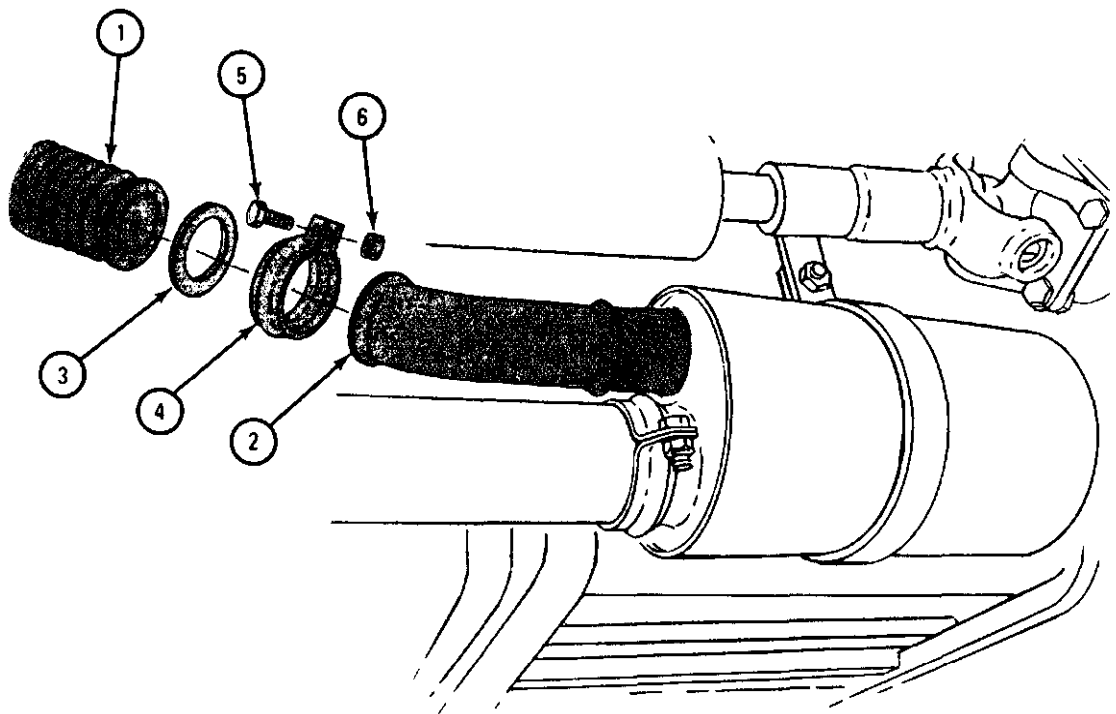

TA 047242

FRAME 7

1. Using 9/16-inch wrenches, evenly tighten three locknuts (1) on three bolts (2).

GO TO FRAME 8

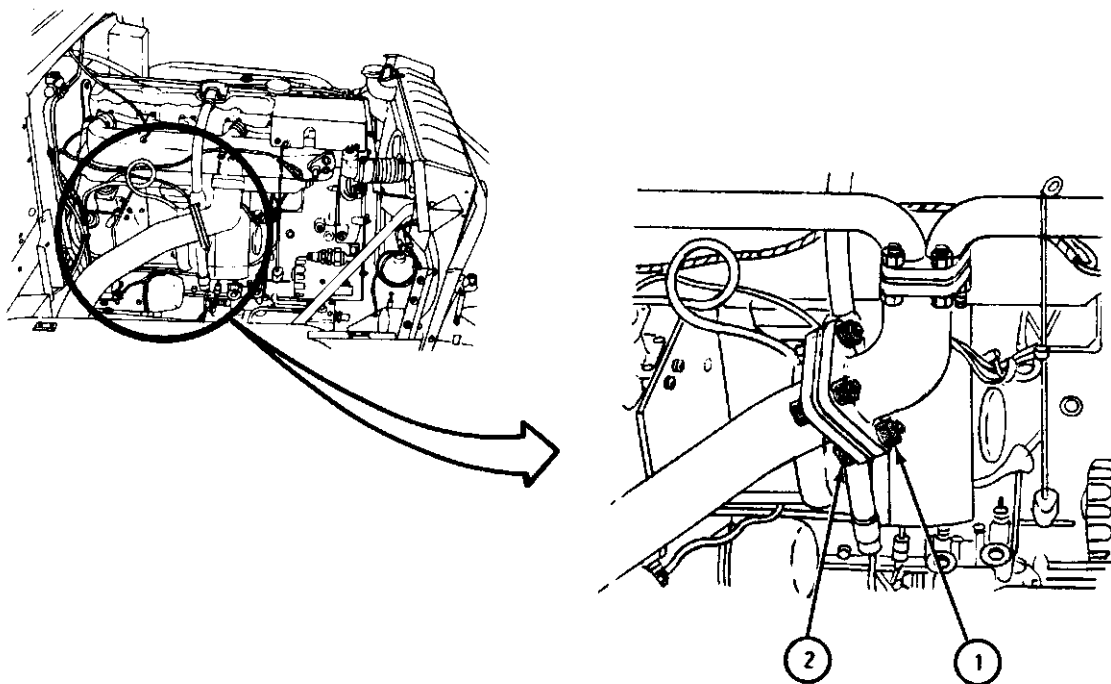

TA 047243

FRAME 8

1. Put fender shield (1) on top of fender (2) and sand shield (3) under fender. Put two bolts (4) through shields and fender.

2. Screw two locknuts (5) on bolts (4) but do not tighten at this time.

GO TO FRAME 9

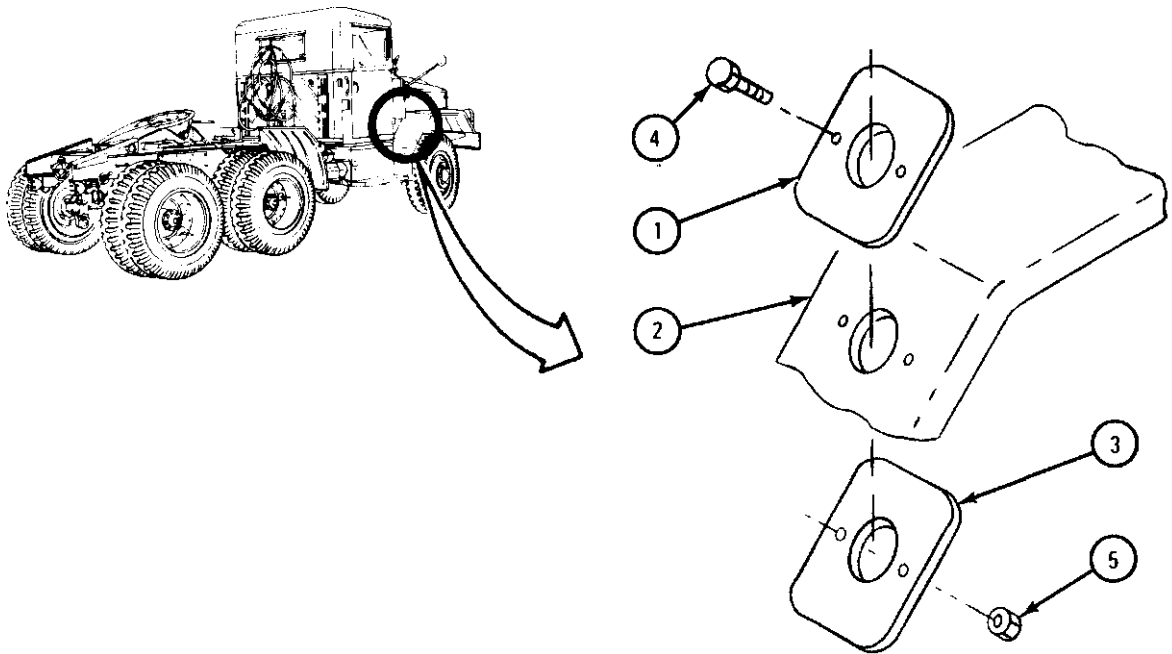

TA 047244

FRAME 9

1. Put two U-bolts (1) through two brackets (2). Set one bracket in top of shield assembly (3) and other bracket in bottom.
2. Put shield assembly (3) against exhaust bracket (4) and push two U-bolts (1) through holes in exhaust bracket.
3. Screw four locknuts (5) on U-bolts (1). Do not tighten locknuts at this time.
4. Slide lower stack pipe (6) up through fender (7), shield (3), and U-bolts (1).

GO TO FRAME 10

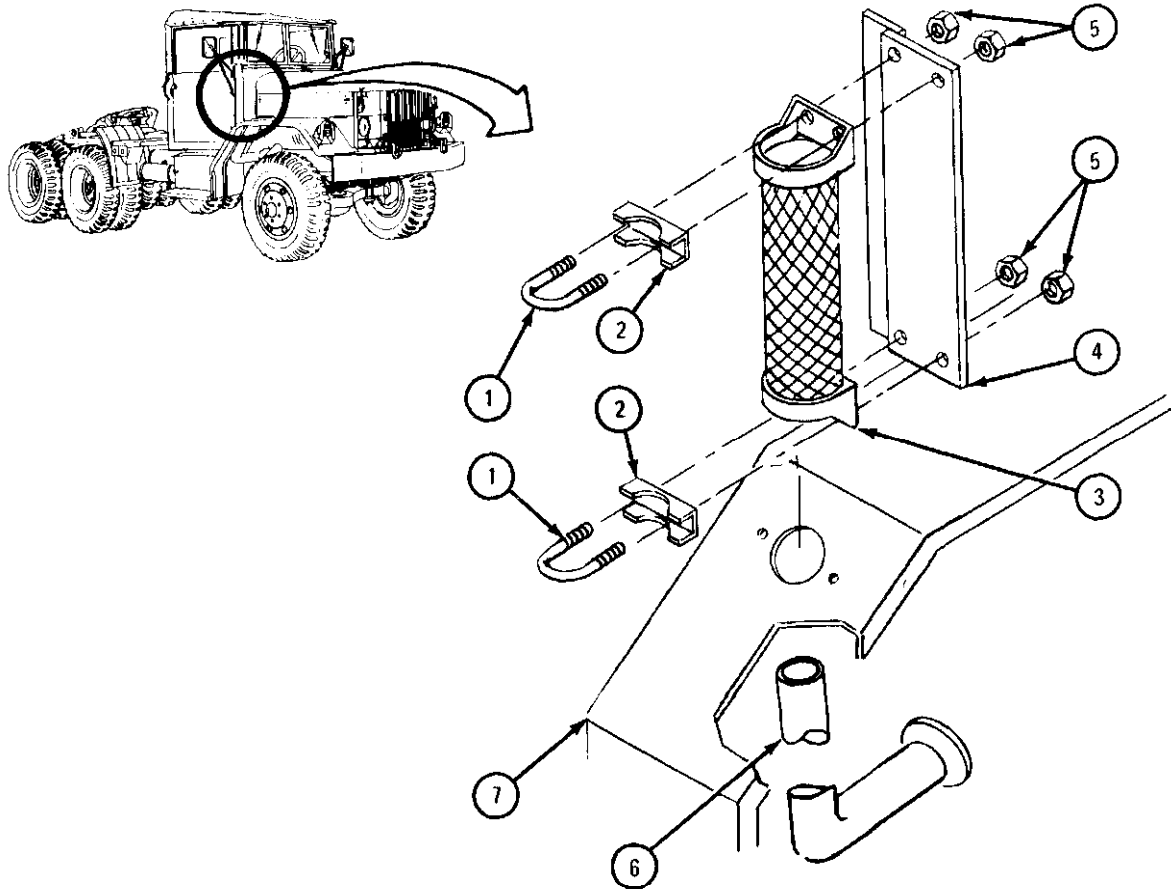

TA 047245

FRAME 10

1. Put gasket (1) against flange (2) of lower stack pipe (3), Spread coupling (4) and put over flange and gasket.
2. Move exhaust flex line (5) as needed to aline flange (6) with flange (2).
3. Join lower stack pipe (3) and exhaust flex line (5) using coupling (4).

NOTE

Coupling (4) must hold both flanges (2 and 6). Make sure gasket (1) stays in coupling.

4. Put bolt (7) through coupling (4) and using 1/2-inch wrenches , screw on and tighten locknut (8).

GO TO FRAME 11

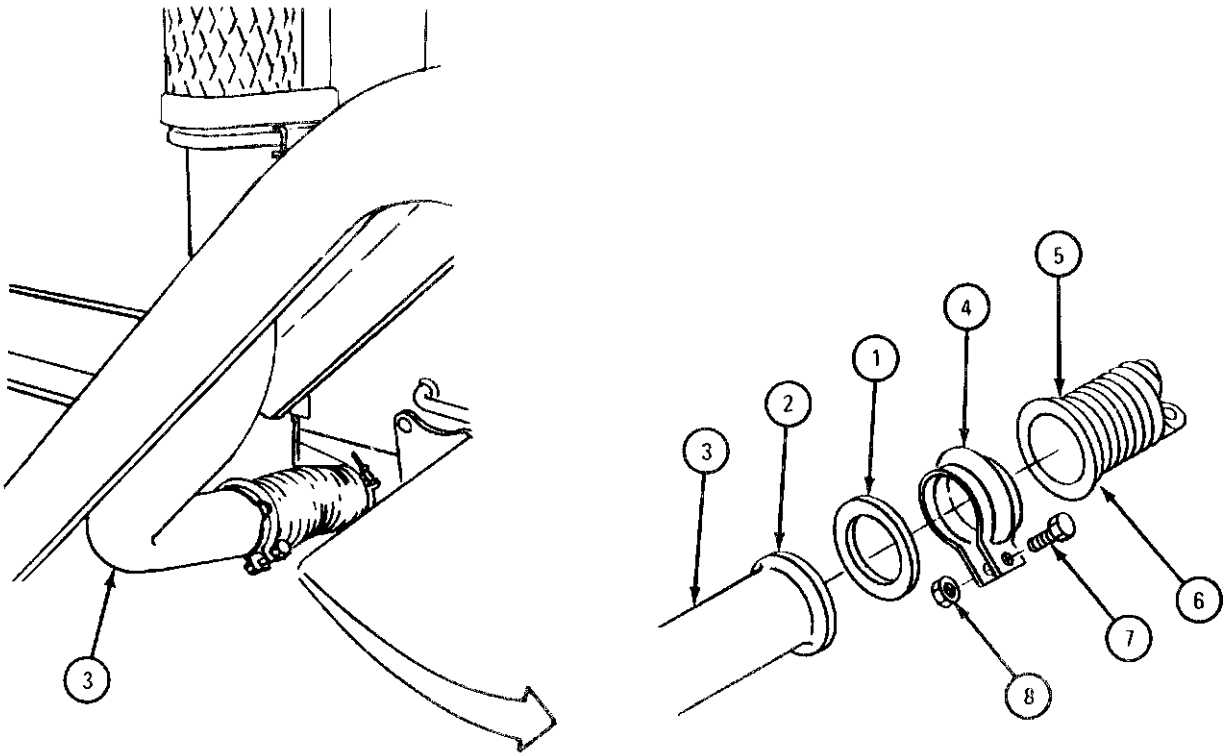

TA 047246

FRAME 11

1. Set top of lower stack pipe (1) to extend 1-inch above U-bolt (2) as shown.
2. Using 1/2-inch wrench, tighten two locknuts (3).
3. Loosen two locknuts (4) as needed, and put upper stack pipe (5) on lower stack pipe (1) . Make sure upper stack pipe is firmly seated.

NOTE

Install upper stack pipe (5) so outlet (6) is out and back.
The angle from truck centerline should be 45°.

4. Using 1/2-inch wrench, tighten two locknuts (4) .

GO TO FRAME 12

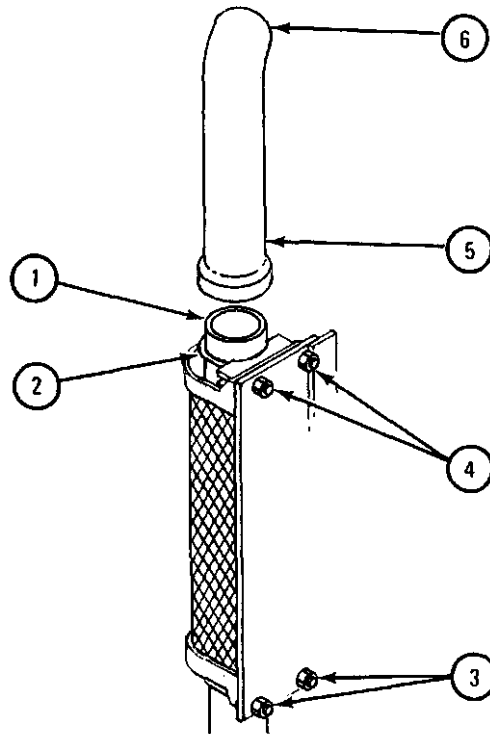

7A 047247

FRAME 12

1. Check sand shield (1) and fender shield (2) to make sure each is flat against fender (3).
2. Using 7/16-inch wrench and 1/2-inch wrench, tighten two locknuts (4) on bolts (5) .

NOTE

Follow-on Maintenance Action Required:

1. Replace air cleaner. Refer to para 4-3.
2. Operate engine and check all exhaust system fittings for leaks.

END OF TASK

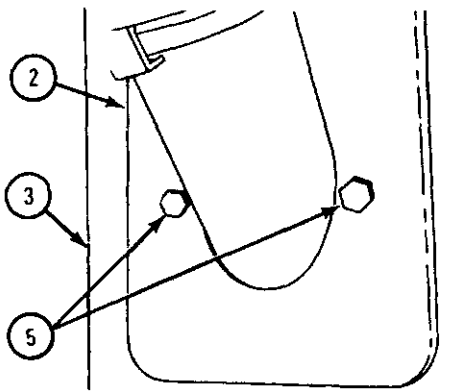
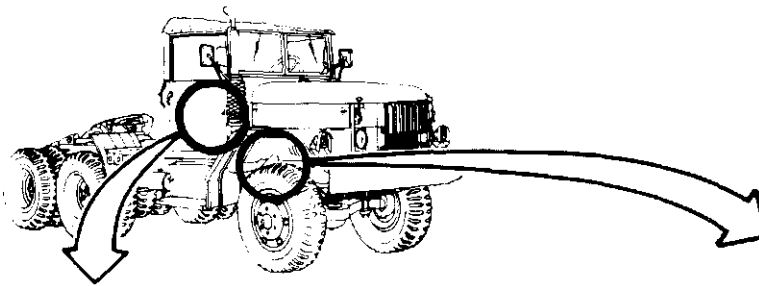

TOP VIEW

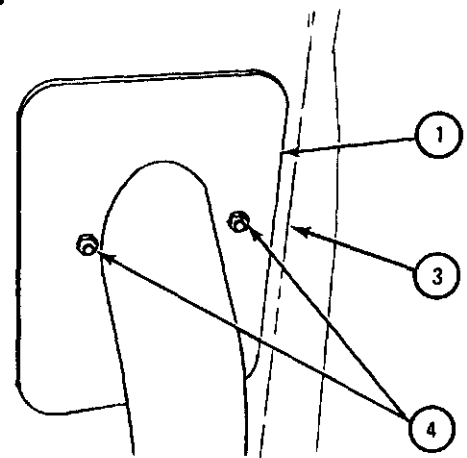

BOTTOM VIEW

TA 047248

5-7. EXHAUST SYSTEM (CLEAN AIR) REMOVAL, AND REPLACEMENT.

TOOLS : 7/16-inch open end wrench 1/2-inch socket wrench
1/2--inch open end wench 9/16-inch socket wrench
9/16-inch open end wrench Slip joint pliers
7/16-inch socket wrench flat--tip screwdriver

SUPPLIES : None

PERSONNEL : One

EQUIPMENT' CONDITION : Truck parked, engine off, handbrake set.

- a. Preliminary Procedure. Remove air cleaner. Refer to para 4-3.
- b. Removal.

FRAME 1

1. Using 1/2-inch wrench, unscrew and take off locknut (1) and bolt (2).
2. Using screwdriver, spread coupling (3) and lift exhaust pipe (4) clear. Throw away gasket (5) and take off coupling.

GO TO FRAME 2

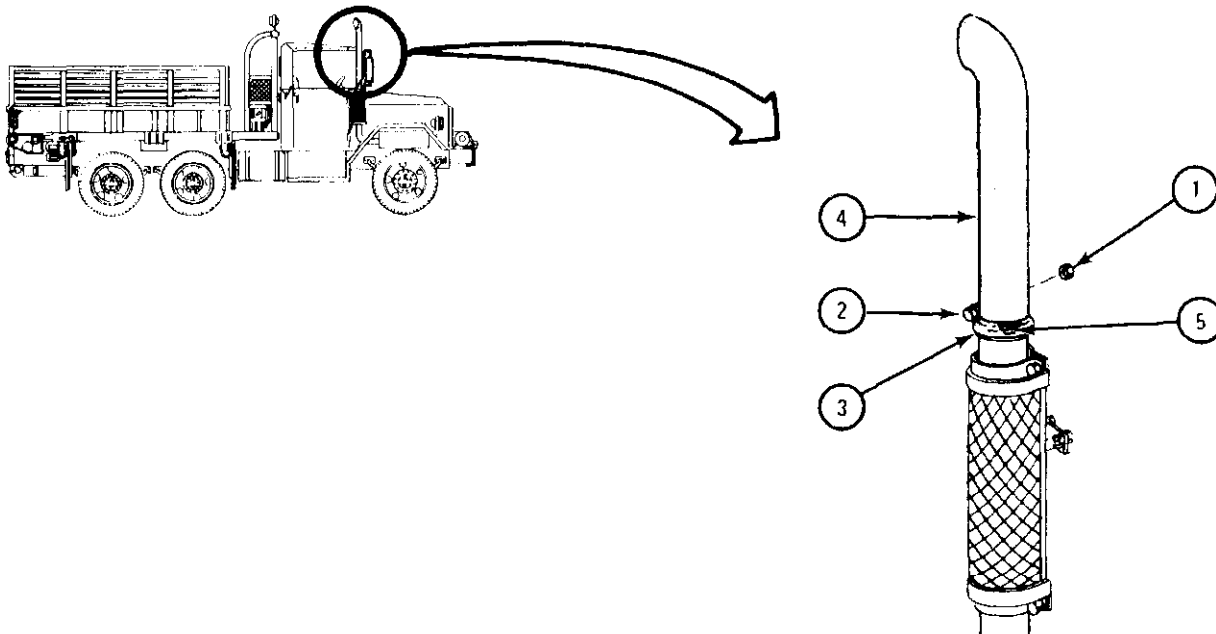

TA 047213

FRAME 2

1. Using 7/16-inch wrench, unscrew and take off four locknuts (1) and four bolts (2). Pull two brackets (3) from exhaust pipe (4).
 2. Take exhaust shield (5) off exhaust pipe (4).
 3. Using 9/16-inch wrench, loosen two nuts (6) on clamp (7).
- GO TO FRAME 3

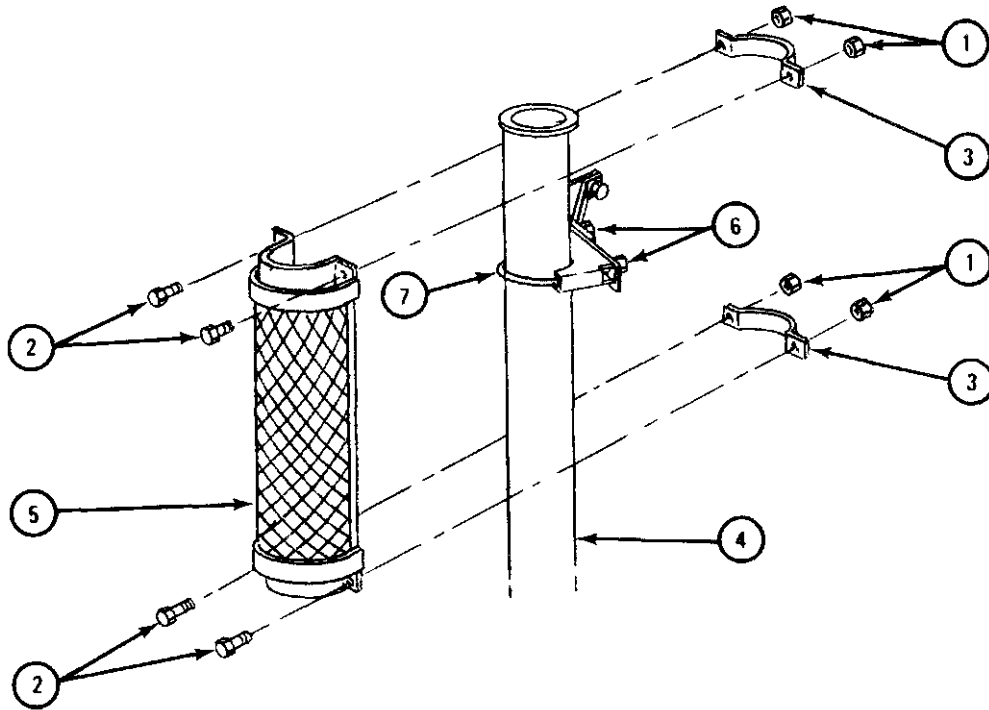

TA 047214

FRAME 3

1. Using 7/16-inch wrenches, unscrew two locknuts (1) from two bolts (2). Take off nuts and two flat washers (3).
2. Take two bolts (2) with flat washers (4) out of cover plates (5).
3. Take off two cover plates (5).

GO TO FRAME 4

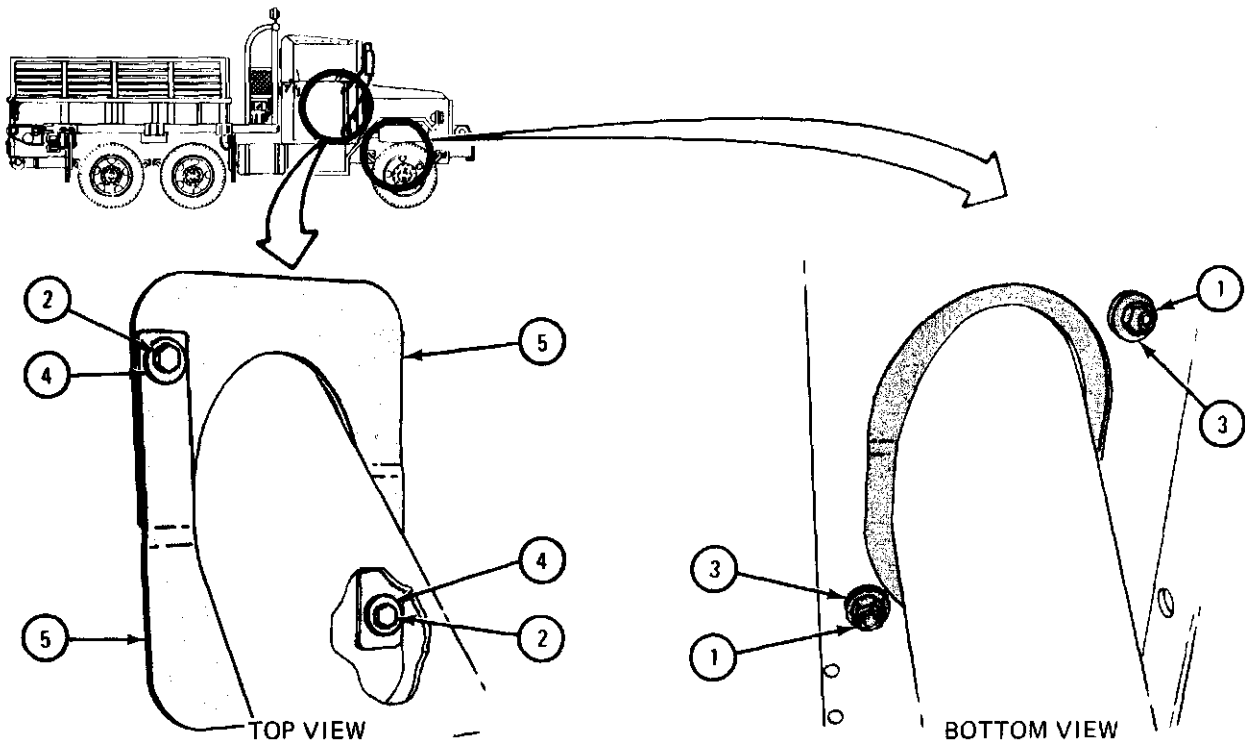

TA 047215

FRAME 4

1. Using 1/2-inch wrench, unscrew and take off locknut (1) . Take off bolt and two flat washers (2) from inside wheel well.
2. Using 1/2-inch wrenches, unscrew and take off locknut (3) and bolt (4) from engine compartment.

CAUTION

Stackway may fall when coupling is taken off. Hold stackway when taking coupling off.

3. Spread coupling (5) and lower exhaust pipe (6) a few inches. Take off clamp (7) and coupling (5) .

GO TO FRAME 5

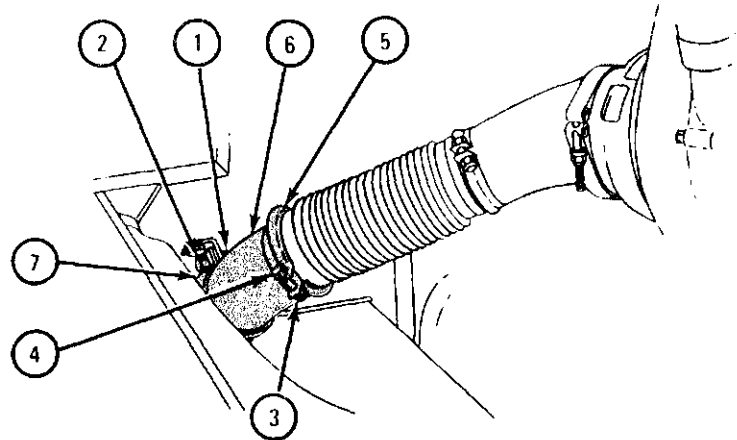
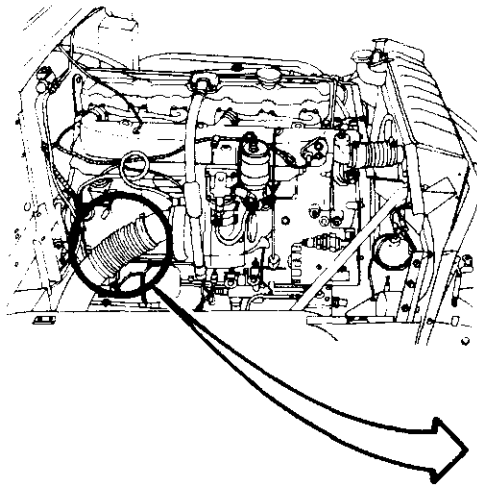

TA 047216

FRAME 5

1. Using 1/2-inch wrenches, unscrew and take off bolt (1) and locknut (2) from coupling (3).
2. Using screwdriver, spread coupling (3) and pull exhaust flex line (4) out of coupling.
3. Take coupling (3) off elbow assembly (5) and throw away gasket (6) .

GO TO FRAME 6

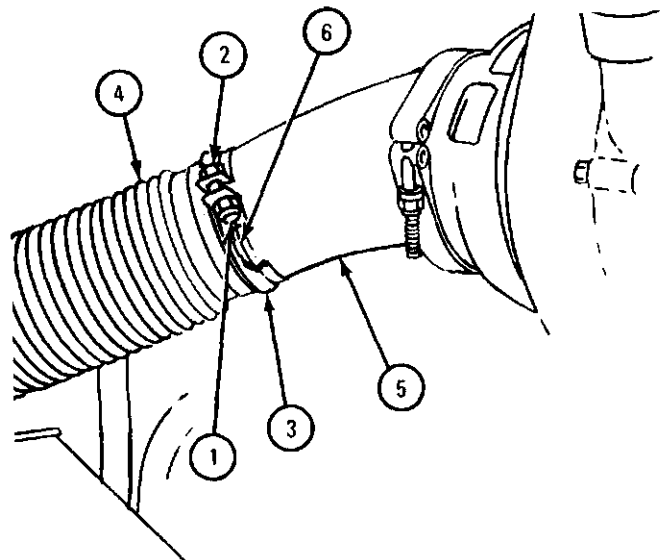

TA 047217

FRAME 6

1. Using 7/16-inch wrench, loosen nut (1) and using screwdriver, spread coupling (2) .
2. Pull elbow assembly (3) out of coupling (2). Throw gasket (4) away and take coupling off turbocharger (5) .

GO TO FRAME 7

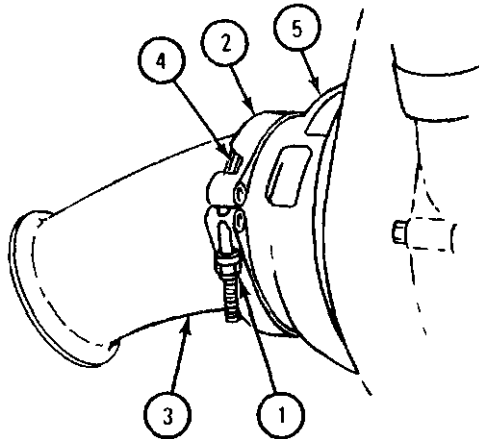

TA 047218

FRAME 7

1. Using 9/16-inch wrench, unscrew and take off two locknuts and flat washers (1).

NOTE

Hold up exhaust pipe (2) when pulling out U-bolt (3).

2. Pull U-bolt (3) out of support brace (4), exhaust support (5), and support block (6).
3. Take exhaust pipe (2) out of truck.

END OF TASK

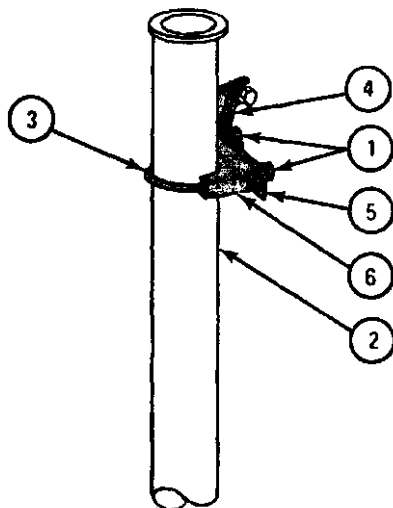

TA 047219

c. Replacement.

FRAME 1

1. Put exhaust pipe (1) through hole in fender (2) and position as shown.
2. Put U-bolt (3) around exhaust pipe (1), through support block (4), and support brace assembly (5).
3. Put two flat washers (6) on U-bolt (3) and screw on two locknuts (7). Using 9/16-inch wrench, snug up locknuts but do not tighten at this time.

GO TO FRAME 2

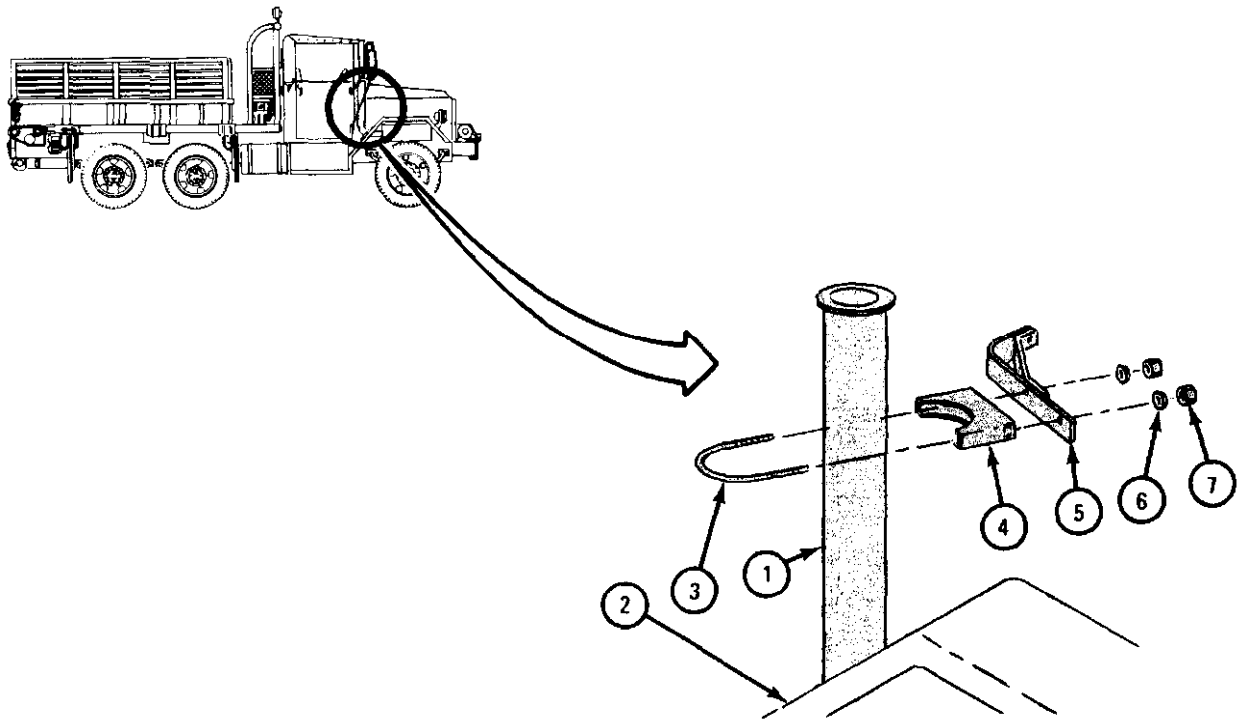

TA 047220

FRAME 2

1. Join elbow assembly (1) to turbocharger (2) by spreading coupling (3) with screwdriver. Put new gasket (4) on flanged end of elbow assembly and put flanged end into coupling.
 2. Using 7/16-inch wrench, snug up locknut (5) but do not tighten at this time.
- GO TO FRAME 3

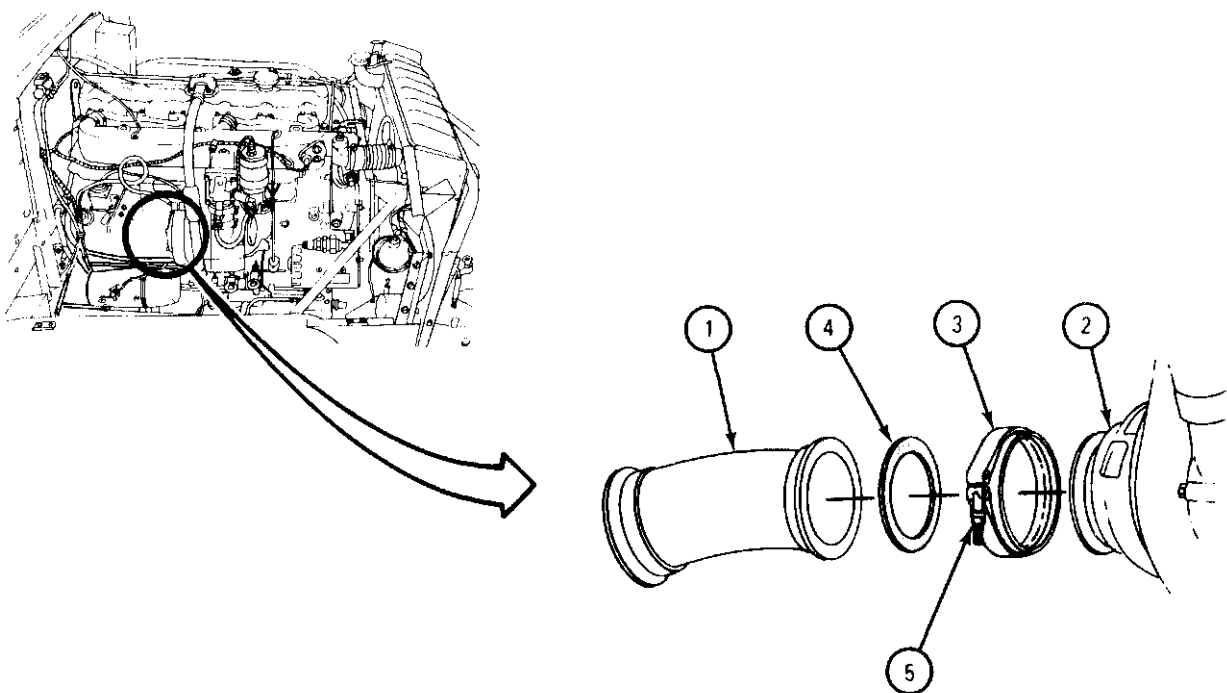

TA 047221

FRAME 3

1. Join exhaust flex line (1) to elbow assembly (2) by spreading coupling (3) using screwdriver. Put new gasket (4) on end of elbow assembly and put flex hose into coupling.
2. Put bolt (5) through coupling (3) and screw on locknut (6). Do not tighten locknut.

GO TO FRAME 4

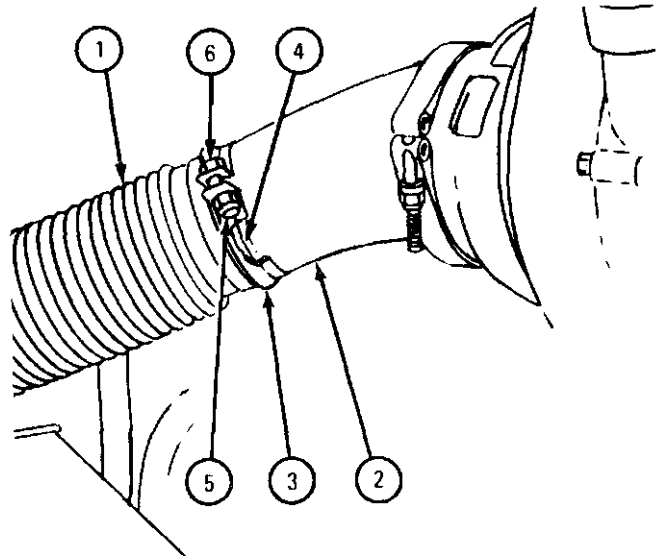

TA 101725

FRAME 4

1. Turn elbow assembly (1) until exhaust flex line (2) is alined with exhaust pipe (3) and end of elbow assembly.

NOTE

Exhaust flex line (2) must form a straight line between elbow assembly (1) and exhaust pipe (3).

2. Using 1/2-inch wrench, tighten locknut (4).
3. Using 9/16-inch wrench, tighten locknut (5).

GO TO FRAME 5

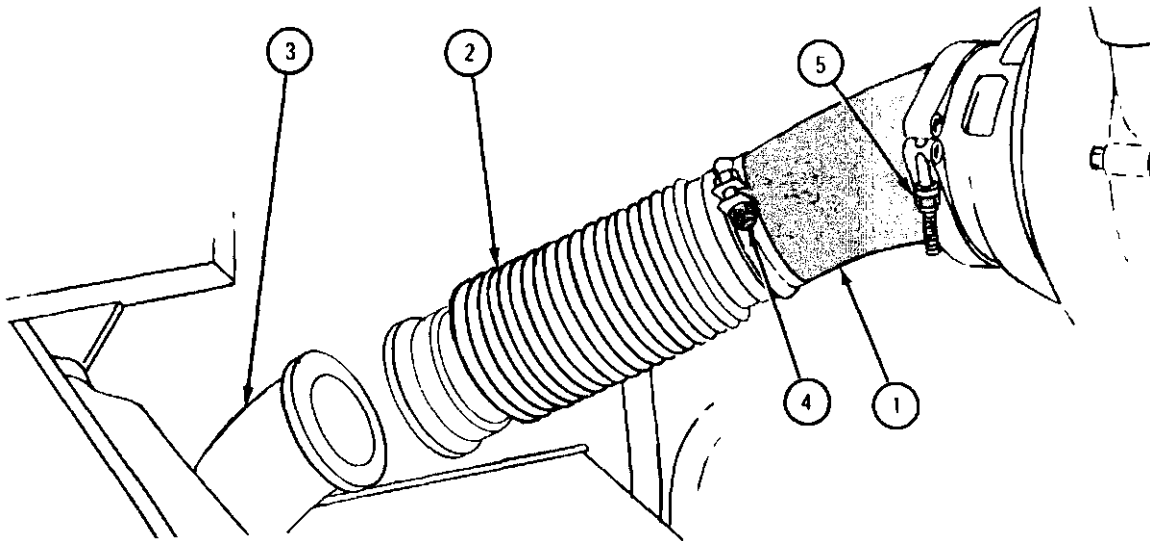

TA 047224

FRAME 5

1. Spread clamp (1) using screwdriver and put on exhaust pipe (2) as shown.
2. Join exhaust pipe (2) to exhaust flex line (3) by spreading coupling (4) using screwdriver. Put new gasket (5) on flanged end of exhaust pipe and put flanged end into coupling.
3. Put bolt (6) through coupling (4) and screw on locknut (7).
4. Using 1/2-inch wrenches, tighten locknut (7).

GO TO FRAME 6

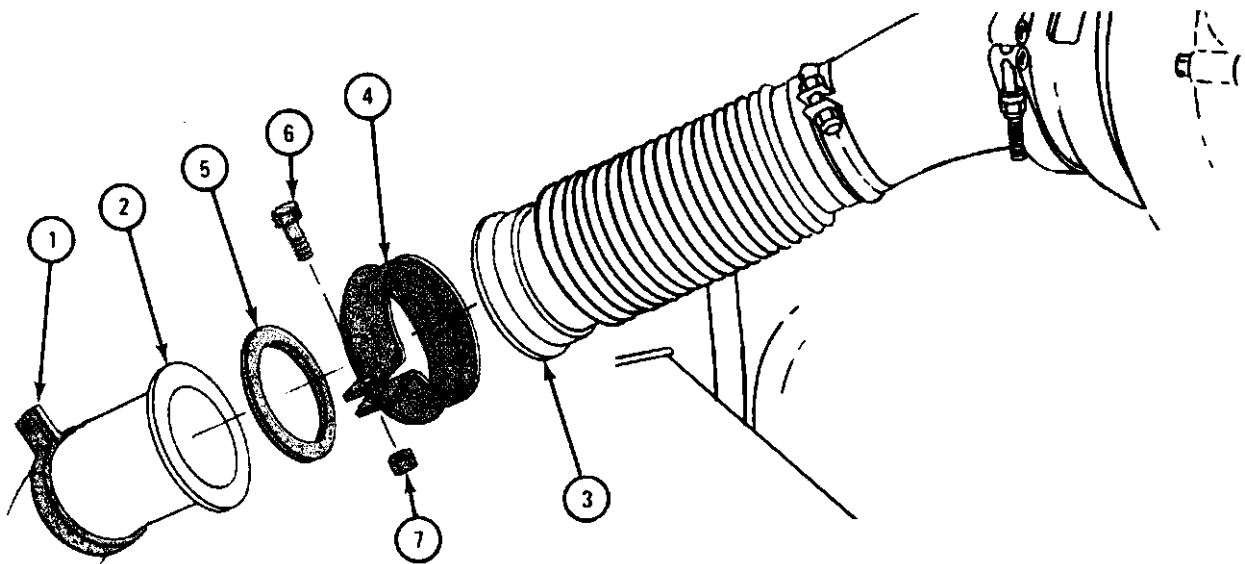

TA 047222

FRAME 6

1. Put clamp (1) against bracket (2). To aline holes, it may be necessary to move clamp on exhaust pipe (3), or to raise exhaust pipe.
2. Put bolt (4) through clamp (1) and bracket (2) and screw on locknut (5). Using 1/2-inch wrenches, tighten locknut.

GO TO FRAME 7

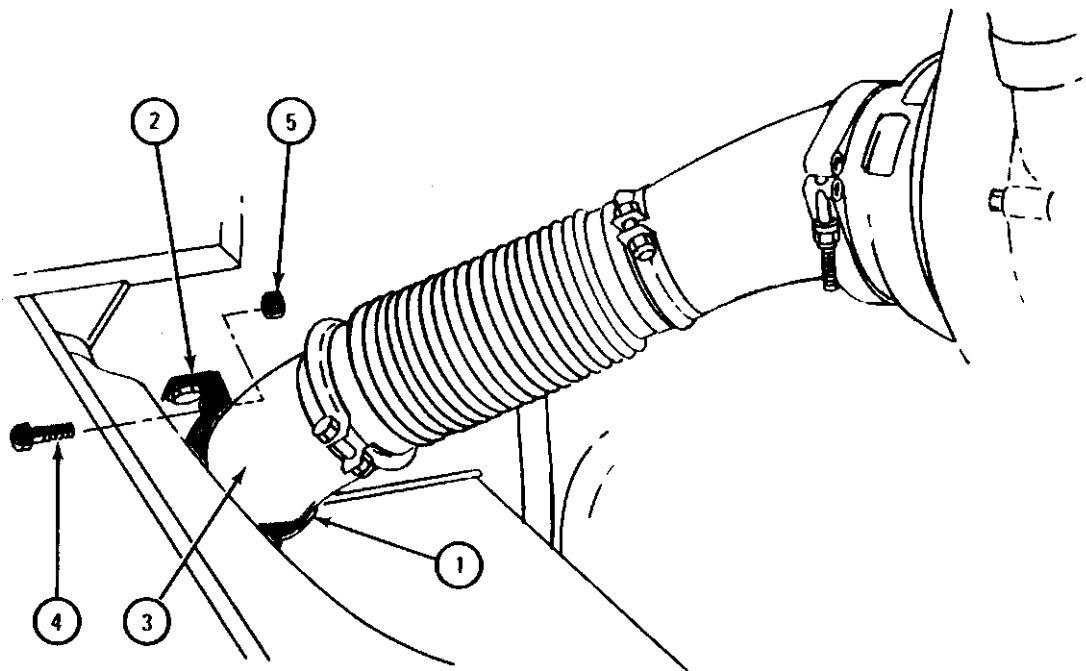

TA 047223

FRAME 7

1. Put two cover plates (1) on top of fender (2) as shown and align mounting holes.
2. Put two bolts (3) with flat washers (4) through cover plates (1) and fender (2).
3. Put two flat washers (5) on bolts (3) and screw on two locknuts (6).
4. Using 7/16-inch wrenches, tighten locknuts (6) .

GO TO FRAME 8

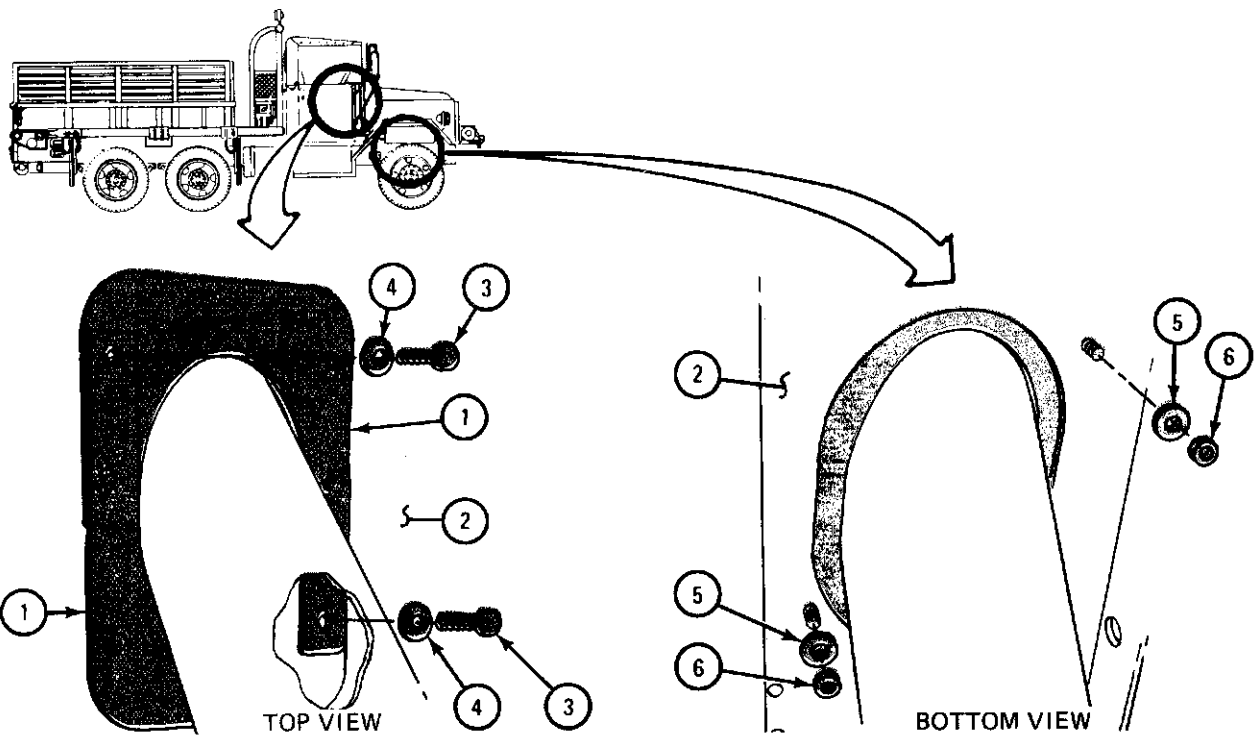

TA 047225

FRAME 8

1. Using 9/16-inch wrench, tighten two locknuts (1).
2. Place exhaust shield (2) on exhaust pipe (3) as shown.
3. Put four bolts (4) through exhaust shield (2) mounting holes. Put two brackets (5) on exhaust pipe (3) and push bolts through bracket mounting holes.
4. Using 7/16-inch wrench, screw on and tighten four locknuts (6).

GO TO FRAME 9

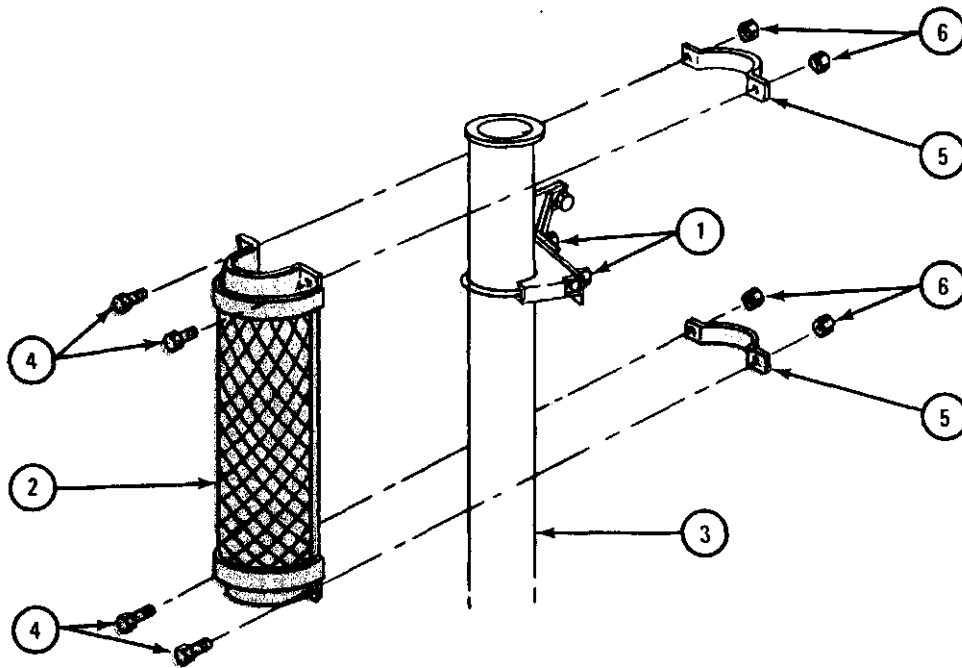

TA 047226

FRAME 9

1. Join upper exhaust pipe (1) to lower exhaust pipe (2) with coupling (3). Spread coupling using screwdriver. Put flanged ends of pipes into coupling with new gasket (4) as shown.
2. Put bolt (5) through coupling (3) and screw on locknut (6) finger tight.
3. Turn upper exhaust pipe (1) to position shown. Using 1/2-inch wrenches, tighten locknut (6) .

NOTE

Follow-on Maintenance Action Required:
Replace air filter element. Refer to para 4-3.

END OF TASK

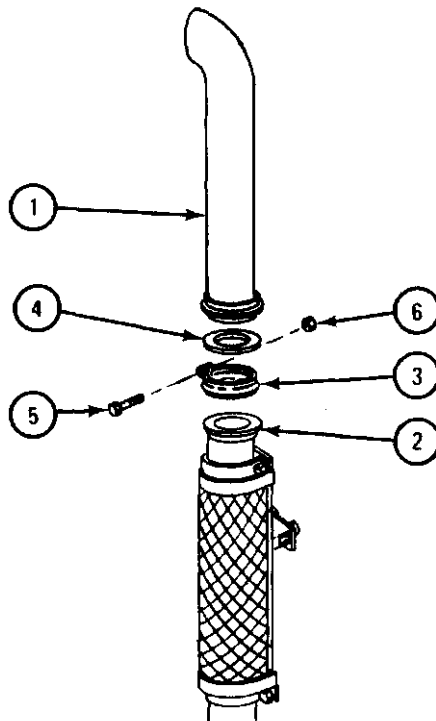

TA 047227

CHAPTER 6

COOLING SYSTEM GROUP MAINTENANCE

Section I. SCOPE

6-1. EQUIPMENT ITEMS COVERED. This chapter gives equipment maintenance procedures for the radiator assembly, thermostat, water pump, fan assembly and related parts and cooling system service for which there are authorized corrective maintenance tasks at the organizational maintenance level.

6-2. EQUIPMENT ITEMS NOT COVERED. All equipment items for which corrective maintenance is authorized at the organizational maintenance level are covered in this chapter.

Section II. RADIATOR ASSEMBLY

6-3. RADIATOR REMOVAL AND REPLACEMENT.

TOOLS : Flat-tip screwdriver
1/2-inch open end wrench
9/16-inch wrench (2)
3/4-inch box wrench (2)

SUPPLIES : None

PERSONNEL : Two

EQUIPMENT CONDITION : Truck parked, engine off, handbrake set.

a. Preliminary Procedures.

(1) Open hood and both side panels. Refer to TM 9-2320-209-10.

(2) Drain cooling system. Refer to para 6-10.

b. Removal.

FRAME 1

1. Using 3/4-inch box wrenches, loosen two nuts (1) from two bolts (2) on left and right sides of brush guard (3).
2. Push up two braces (4) to unlatch braces from two bolts (2).

GO TO FRAME 2

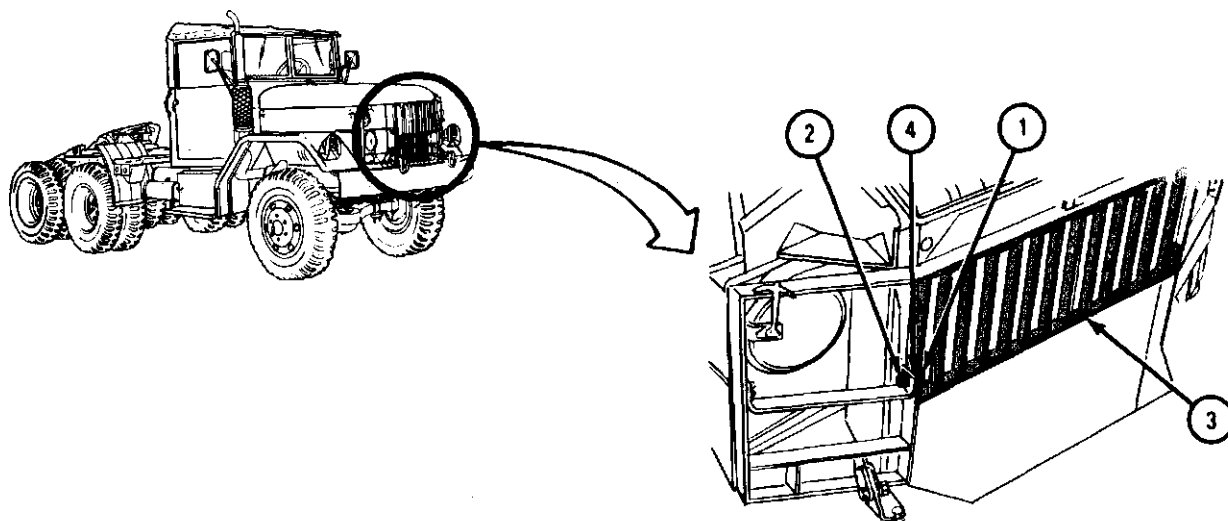

TA 047027

FRAME 2

- 1. Using 3/4-inch box wrenches, loosen two nuts (1) on two bolts (2) at left and right side of brush guard (3).
 - 2. Lift brush guard (3) off frame brackets (4) and set brush guard aside.
- Soldiers A and B
- GO TO FRAME 3

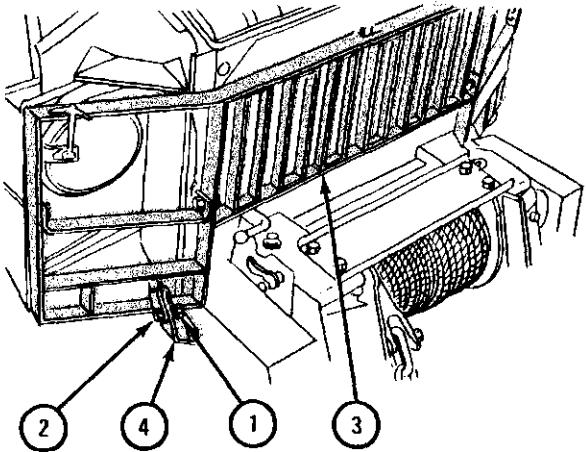
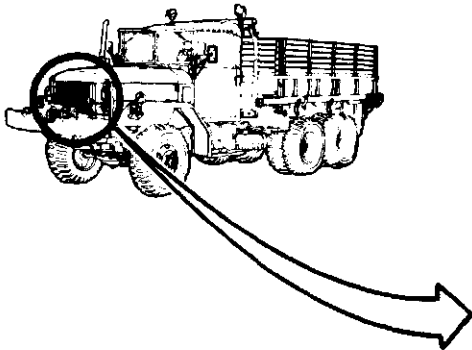

TA 047028

FRAME 3

1. Using 3/4-inch wrench, unscrew and take off two locknuts (1) from two radiator mounting studs (2).
2. Take four flat washers (3) and two springs (4) off two radiator mounting studs (2).
3. Using 9/16-inch wrenches , unscrew and take off locknut (5) from bolt (6) at bottom right of radiator frame.
4. Take Lockwasher (7) off bolt (6) and pull ground strap (8) off bolt.
5. Take out bolt (6) .

GO TO FRAME 4

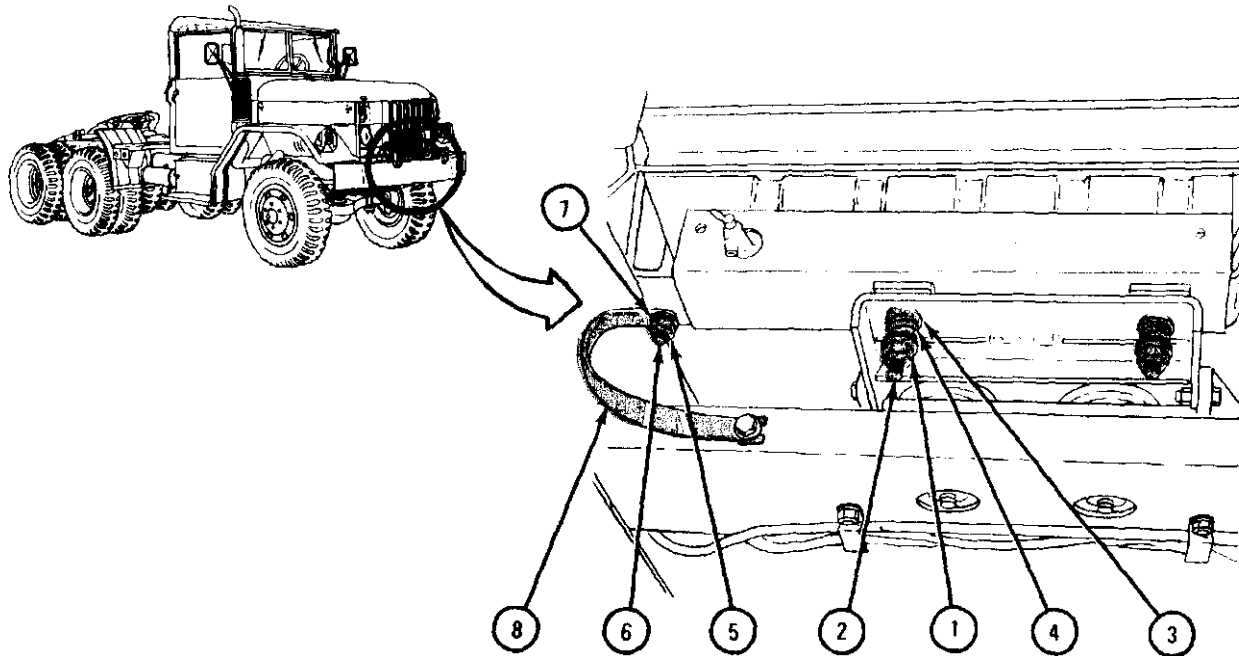

TA 047029

FRAME 4

1. Using screwdriver, loosen screw (1) on hose clamp (2) and slide hose clamp back on hose (3).
2. Loosen hose (3) from inlet fitting (4).
3. Using screwdriver, loosen screw (5) on hose clamp (6) and pull hose away from thermostat (7).

GO TO FRAME 5

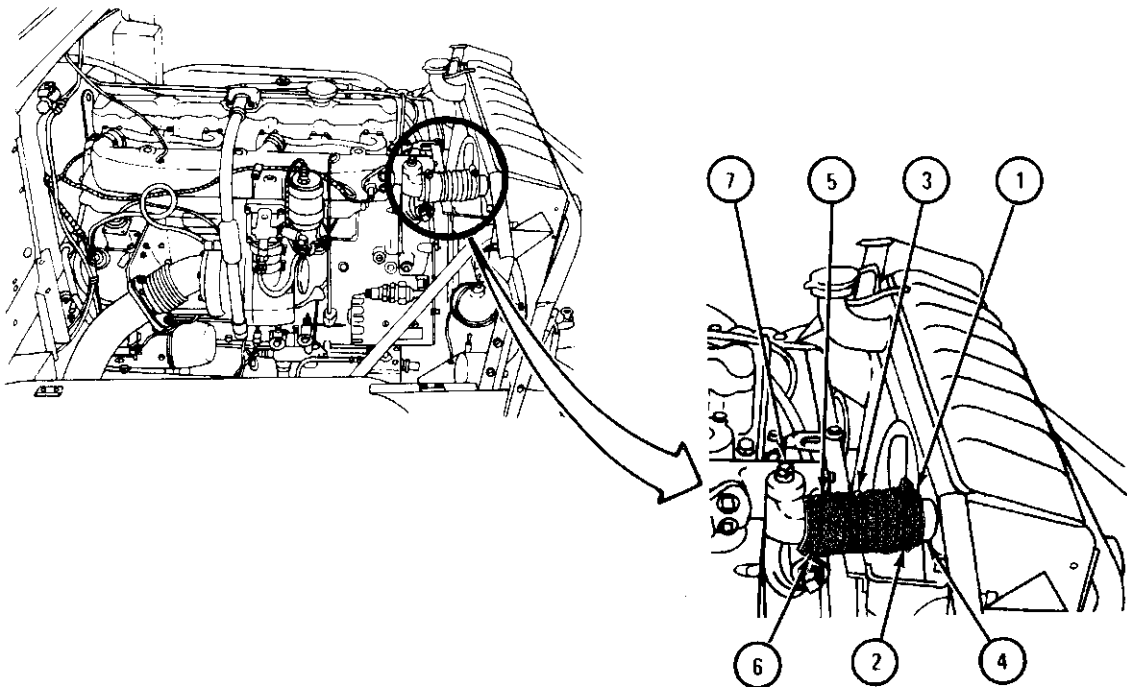

TA 047030

FRAME 5

1. Using screwdriver, loosen screw (1) on hose clamp (2) and slide hose clamp back on hose (3).
2. Loosen hose (3) from outlet fitting (4).

GO TO FRAME 6

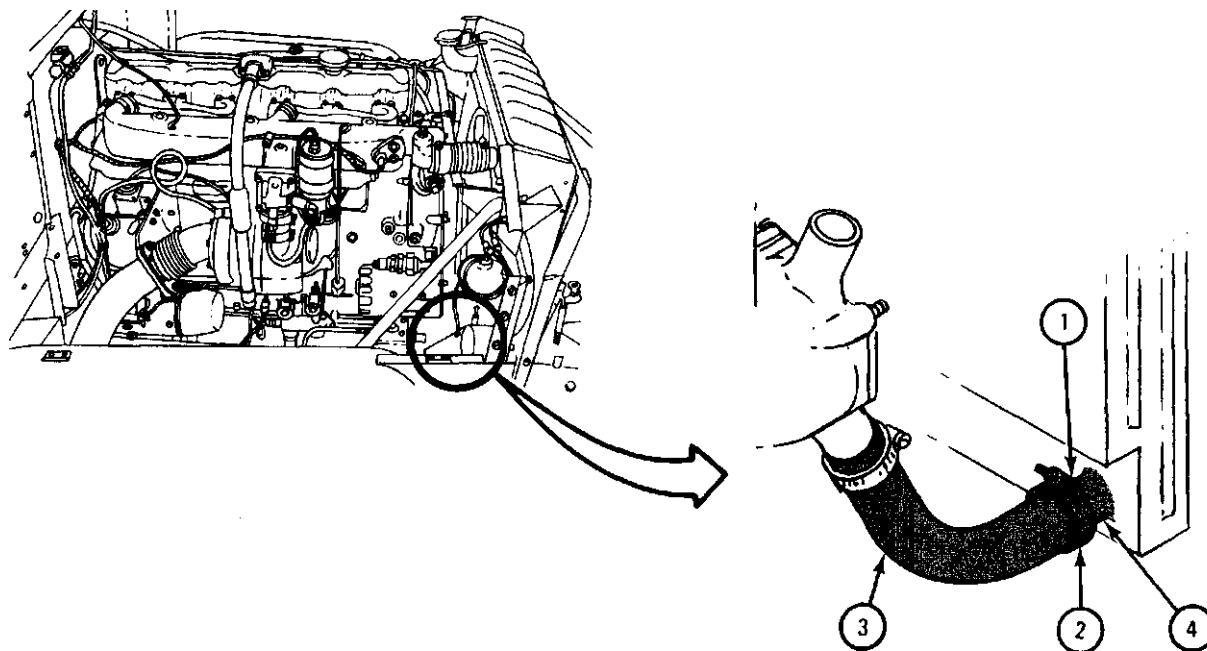

TA 047031

FRAME 6

1. Using 9/16-inch wrenches, unscrew and take off locknut (1) from bolt (2).
2. Take out bolt and tilt radiator (3) forward.
3. Using 1/2-inch wrench, take out four bolts (4). Take off fan blade (5).

CAUTION

When removing radiator (3), be very careful not to damage shroud (6) and core (7) on engine cooling fan.

Soldiers A and B 4. Tilt radiator (3) forward as shown and lift radiator out of engine compartment.

5. Take two shims (8) off two radiator mounting studs (9).

END OF TASK

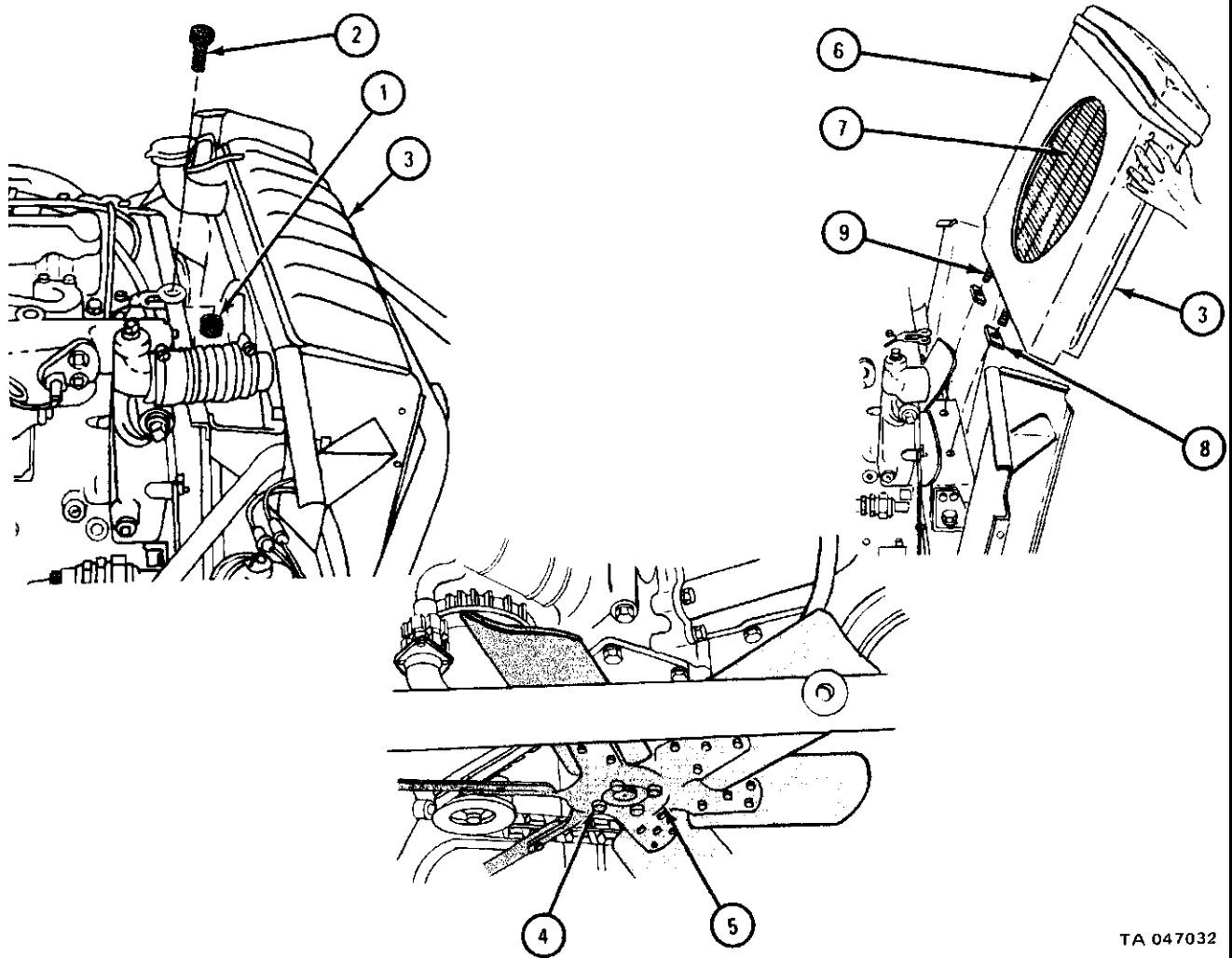

TA 047032

c. Replacement.

FRAME 1

1. Put two shims (1) on two radiator mounting studs (2).
2. Tape shims (1) to bottom of radiator (3) using short lengths of masking tape. This will prevent shims from dropping off during installation.

CAUTION

Be very careful when putting radiator into engine compartment. Core (4) and shroud (5) can be easily damaged.

Soldiers 3. Lower radiator (3) into engine compartment. Radiator mounting studs A and B (2) must go through holes (6) in bracket (7) as shown.

GO TO FRAME 2

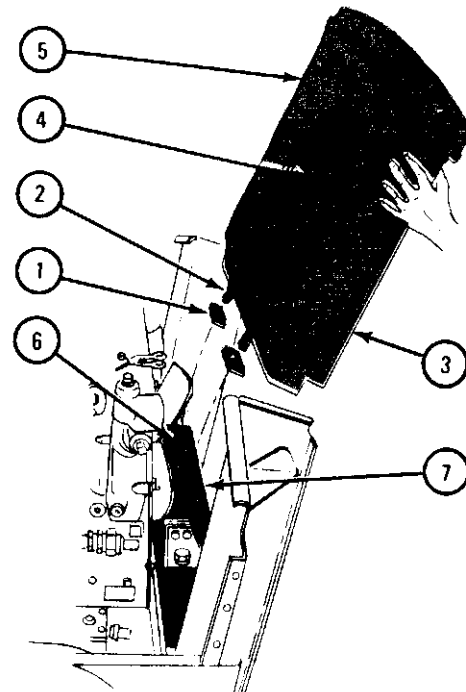
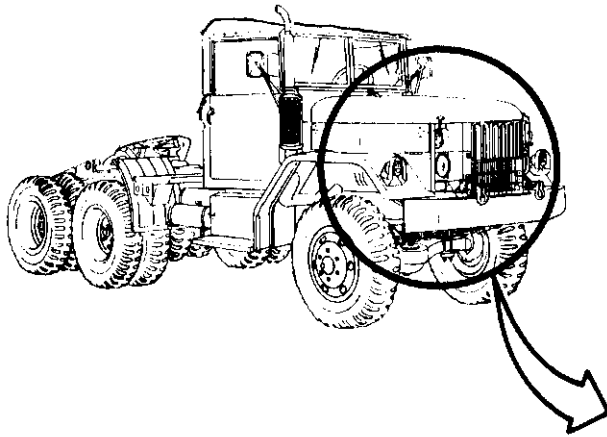

TA 047033

FRAME 2

1. Put fan blade (1) onto cooler pump and aline holes. Using 1/2-inch wrench, screw in and tighten four bolts (2) .
2. Push top of radiator forward or backward to aline hole in clevis (3) with hole in bracket (4).
3. Put bolt (5) through clevis (3) and bracket (4) as shown.
4. Using 9/16-inch wrenches, screw in and tighten locknut (6) on bolt (5).

GO TO FRAME 3

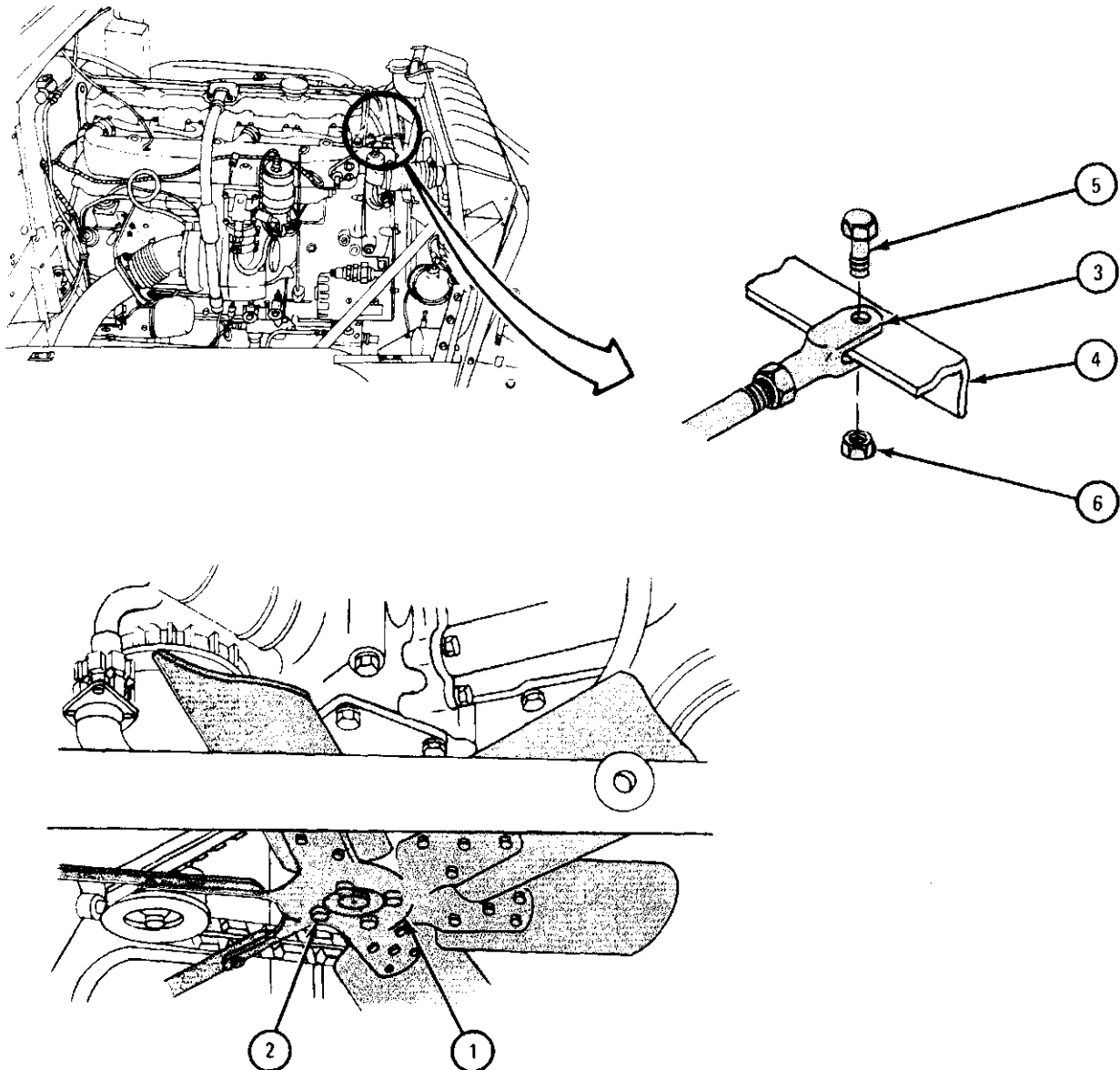

T/A 047034

FRAME 3

1. Put two flat washers (1) and spring (2) on each radiator mounting stud (3). Screw one locknut (4) on each stud.
2. Using 3/4-inch wrench, tighten each locknut (4) evenly to compress springs (2) against bracket (5). Do not compress springs all the way.

GO TO FRAME 4

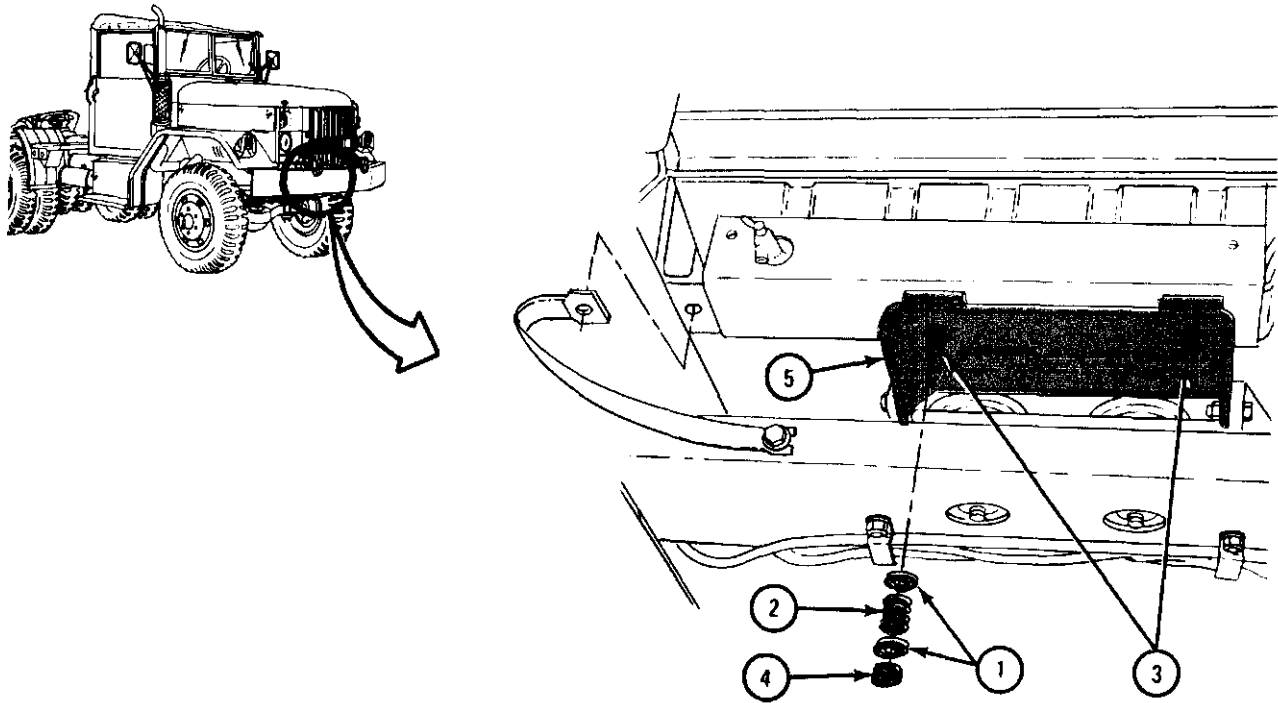

TA 047035

FRAME 4

1. Put bolt (1) through hole in radiator frame (2). Put end of ground strap (3) on bolt.
2. Put lockwasher (4) on bolt (1) and screw on nut (5). Using 9/16-inch wrenches, tighten nut.

GO TO FRAME 5

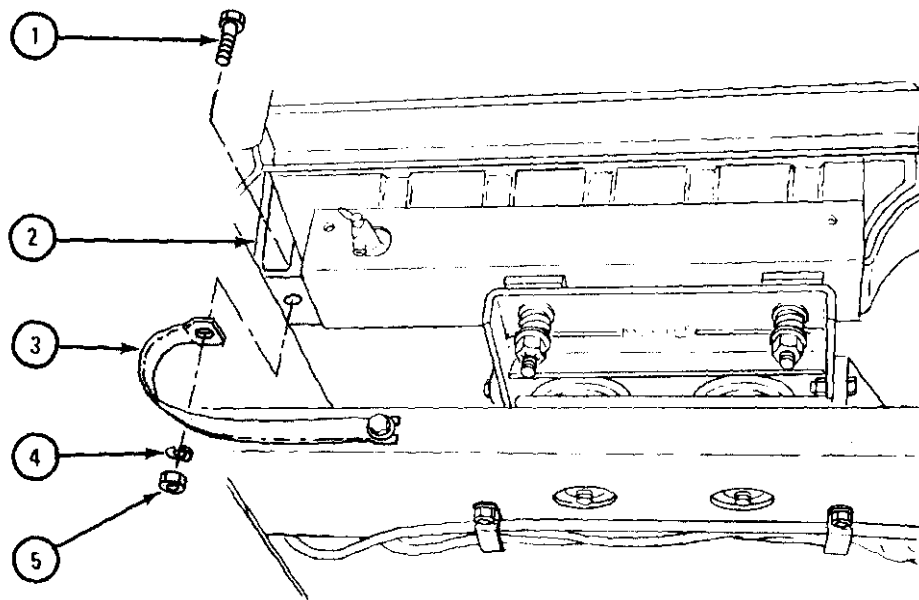

TA 047384

FRAME 5

1. Put hose (1) on inlet fitting (2) and place hose clamp (3) squarely over inlet fitting. Using screwdriver, tighten clamp screw (4).
2. If hose (1) was removed from engine, put other end of hose on thermostat (5). Place hose clamp (6) squarely over hose on thermostat outlet. Using screwdriver, tighten clamp screw (7).

GO TO FRAME 6

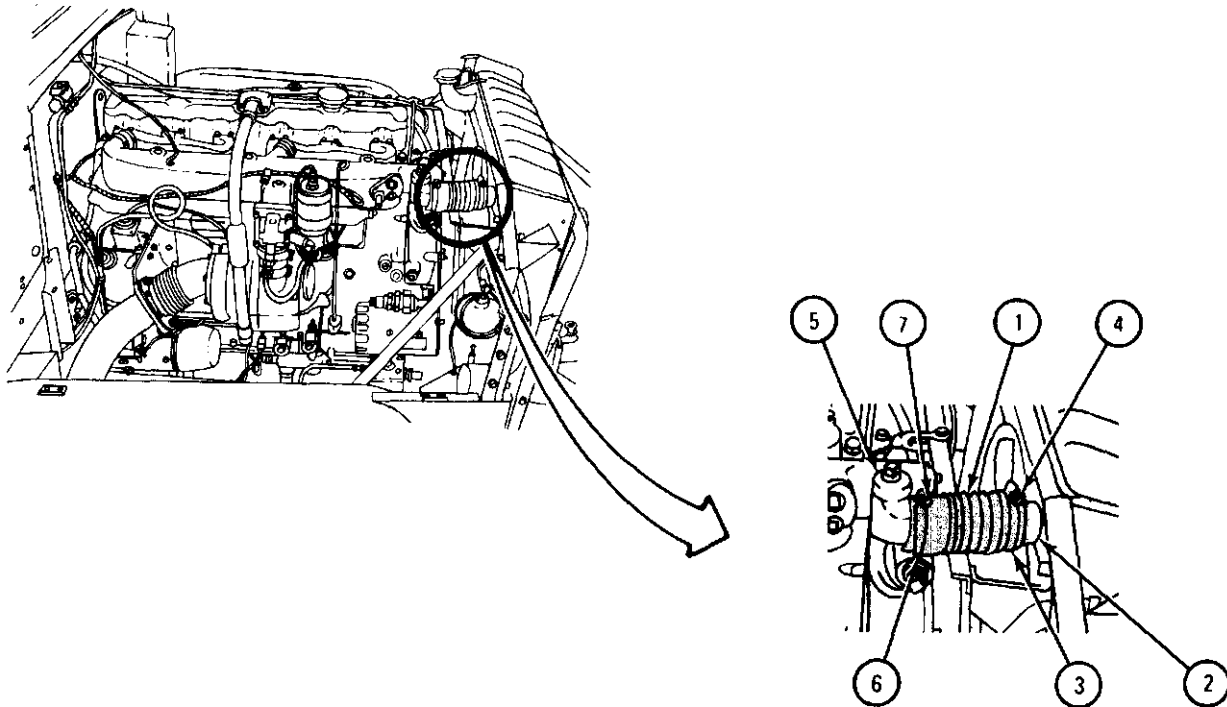

TA 047036

FRAME 6

1. Put hose (1) on radiator outlet fitting (2) and place clamp (3) squarely over hose on outlet fitting. Using screwdriver, tighten clamp screw (4),
2. If hose (1) was removed from engine, put other end of hose on water pump (5). Place clamp (6) squarely over hose on water pump. Using screwdriver, tighten clamp screw (7).

GO TO FRAME 7

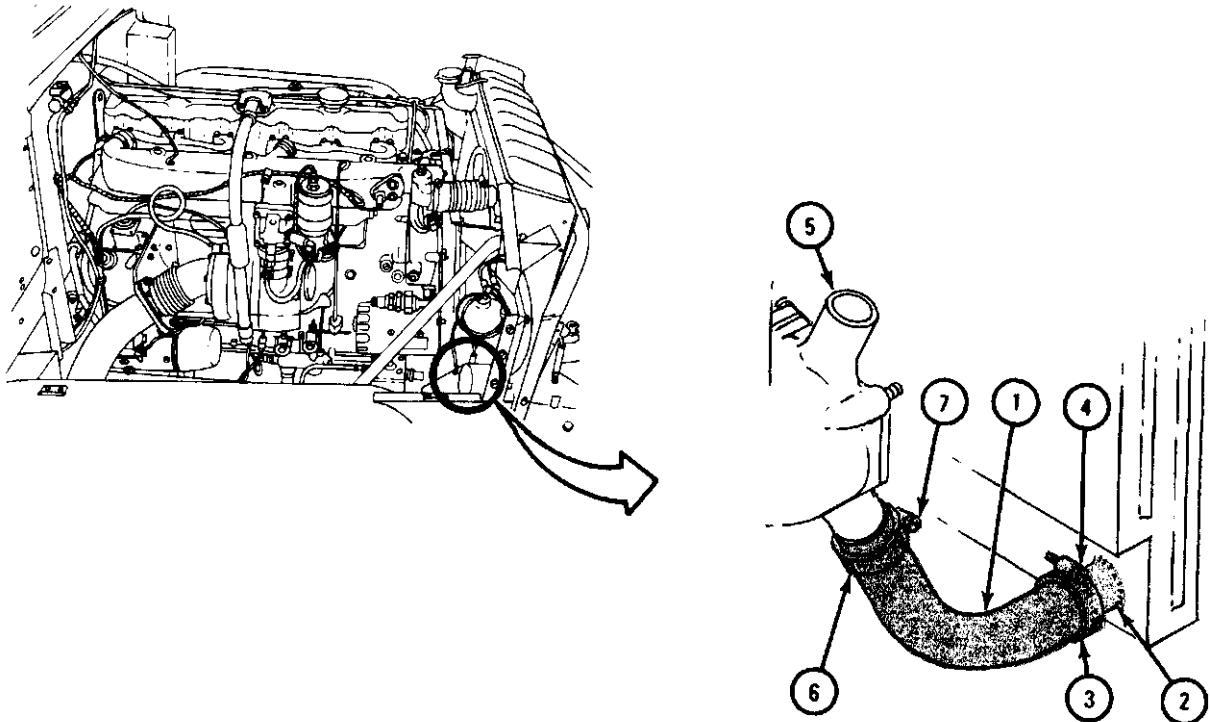

TA 047037

FRAME 7

Soldiers 1. Lift brush guard (1) and put on truck as shown.
A and B

Soldier A 2. Guide brush guard (1) in place so left and right mounting bolts (2) fit into slots of left and right frame brackets (3).

GO TO FRAME 8

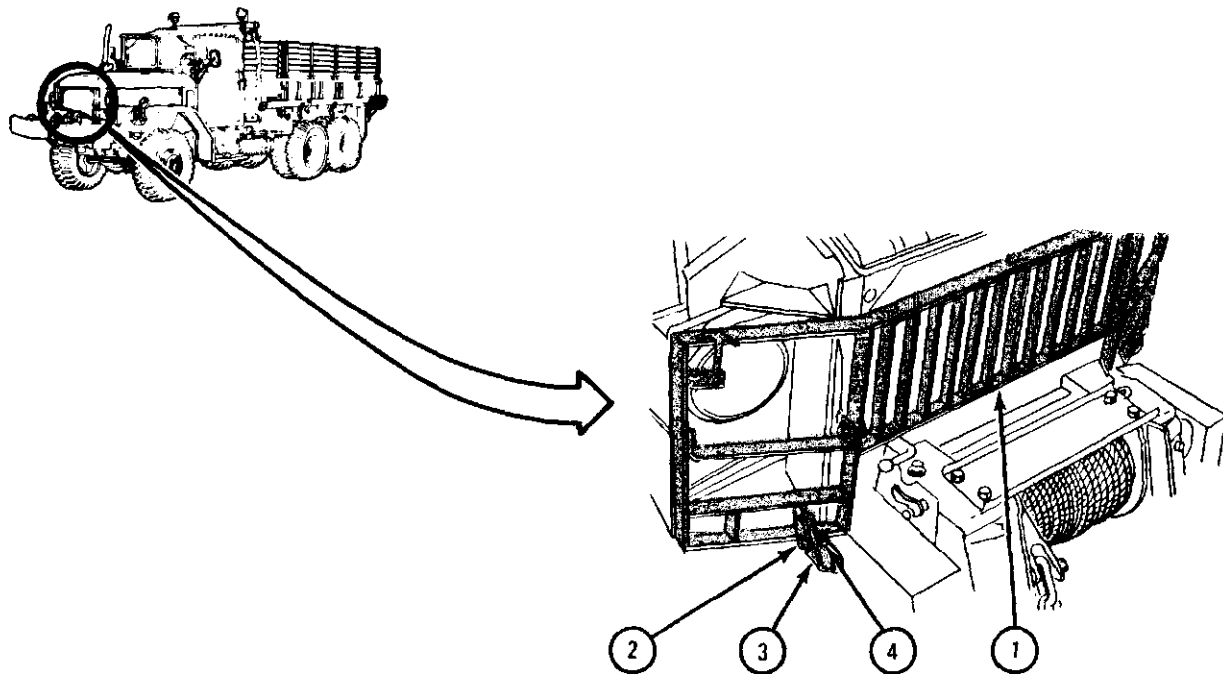

TA 047038

FRAME 8

1. Push in top of brush guard (1). Latch brace (2) on bolt (3) at left and right sides of brush guard.
2. Using 3/4-inch wrenches, tighten locknut (4) on bolt (3) at left and right sides of brush guard (1).
3. Using 3/4-inch wrenches, tighten locknut (5) on bolt (6) at left and right sides of brush guard (1).

NOTE

Follow-on Maintenance Action Required:

1. Fill cooling system. Refer to para 6-10.
2. Start engine. Refer to TM 9-2320-209-10.
3. Check radiator hoses for leaks.
4. Stop engine. Refer to TM 9-2320-209-10.
5. Close hood and side panels. Refer to TM 2320-209-10.

END OF TASK

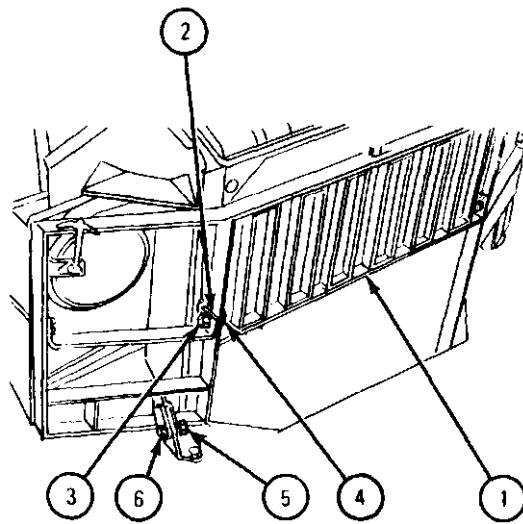

TA 047039

6-4. RADIATOR STONE SHIELD REMOVAL AND REPLACEMENT.

TOOLS : 9/16-inch wrench (2)
7/16-inch wrench (2)
3/4-inch boxwrench (2)

SUPPLIES: None

PERSONNEL: One

EQUIPMENT CONDITION: Truck parked, engine off, handbrake set.

- a. Preliminary Procedure. Open hood. Refer to TM 9-2320-209-10.
- b. Removal.

FRAME 1

1. Using 3/4-inch box wrenches, loosen two nuts (1) from two bolts (2) on left and right sides of brush guard (3).
2. Push up two braces (4) from two bolts (2) and then pull top of brush guard (3) forward.

GO TO FRAME 2

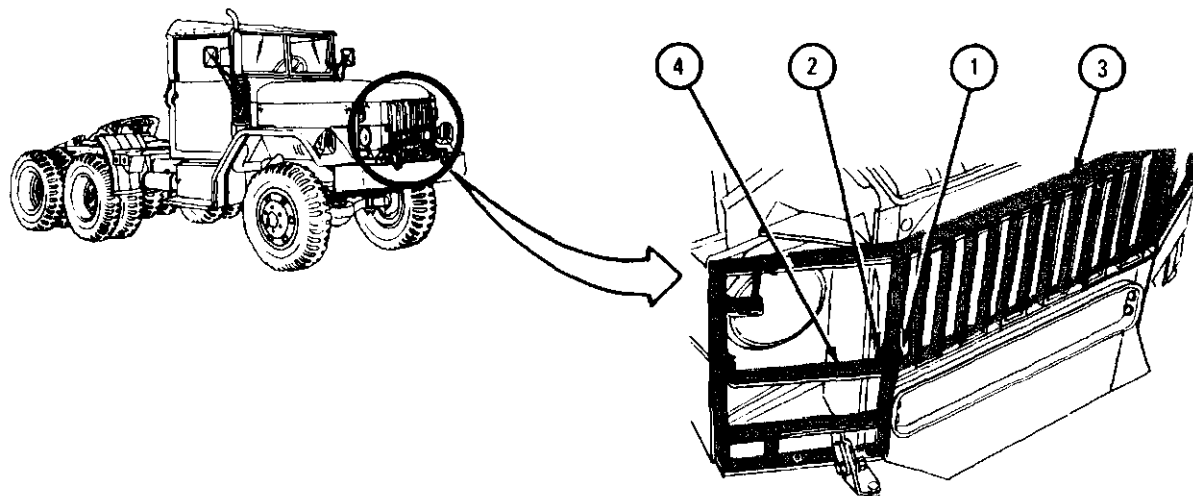

TA 101642

FRAME 2

1. Using 7/16-inch wrenches, unscrew and take off five screws (1). Take off five nuts (2) with five brackets (3).
2. Lift off upper stone shield (4).
3. Using 9/16-inch wrenches, unscrew and take off two screws (5) and nuts (6). Take out lower stone shield (7).

END OF TASK

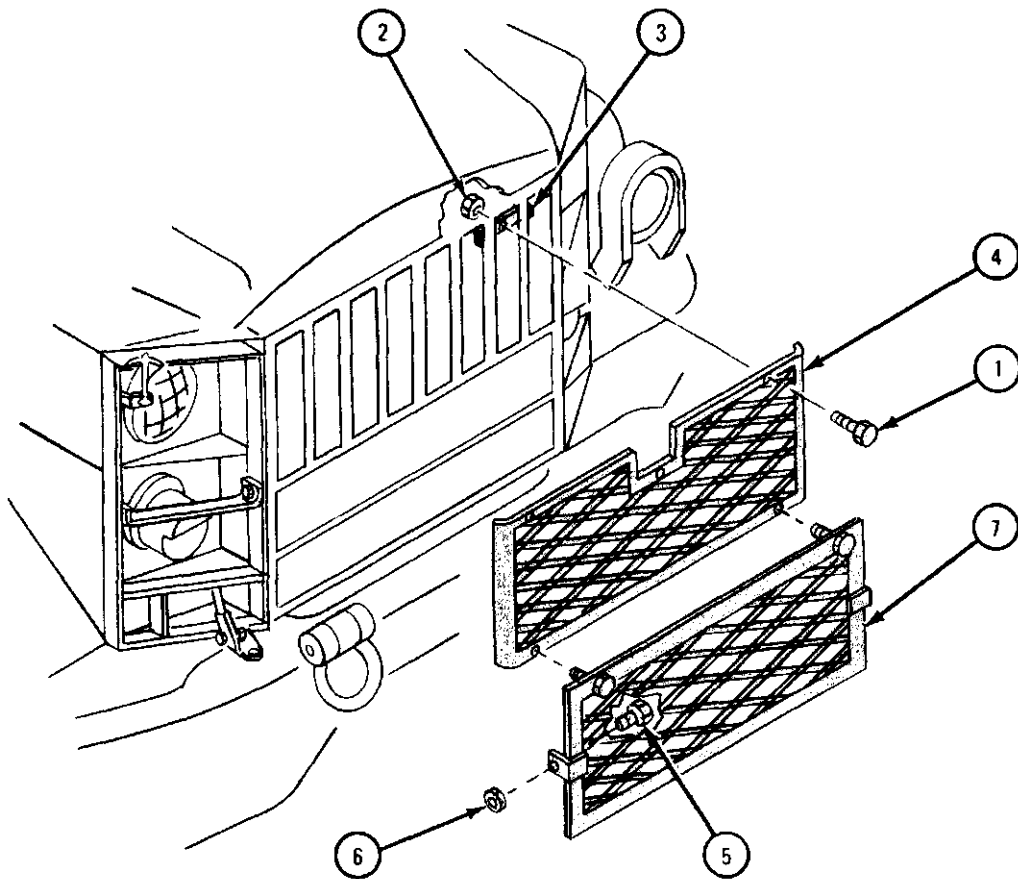

TA 083358

c. Replacement.

FRAME 1

1. Put lower stone shield (1) in place, alining two holes.
2. Using 9/16-inch wrenches, screw in and tighten two screws (2) and nuts (3).
3. Put upper stone shield (4) in place, alining five holes.
4. Hold five brackets (5) in place behind brush guard (6), alining holes. Using 7/16-inch wrenches, screw in and tighten five screws (7) and nuts (8).

GO TO FRAME 2

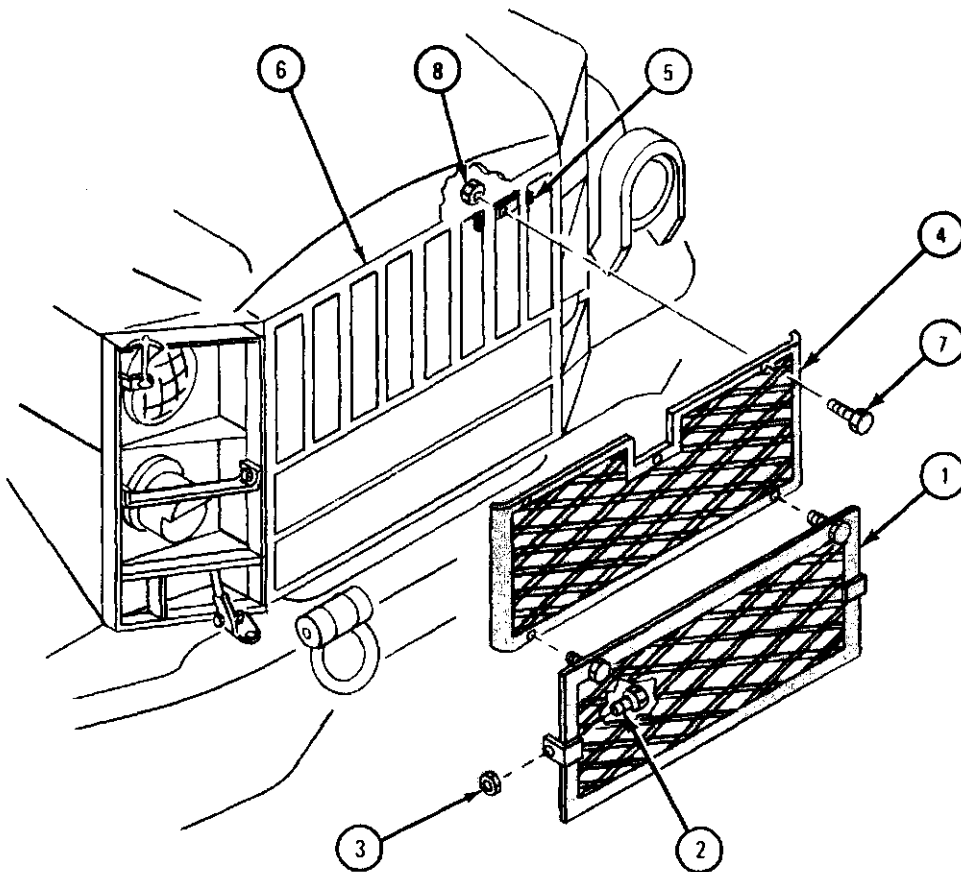

TA 083359

FRAME 2

1. Push in top of brush guard (1). Latch two braces (2) on bolts (3) at left and right sides of brush guard.
2. Using 3/4-inch wrenches, tighten locknut (4) on bolt (3) at left and right sides of brush guard (1).

NOTE

Follow-on Maintenance Action Required:

Close hood. Refer to TM 9--2320-209-10.

END OF TASK

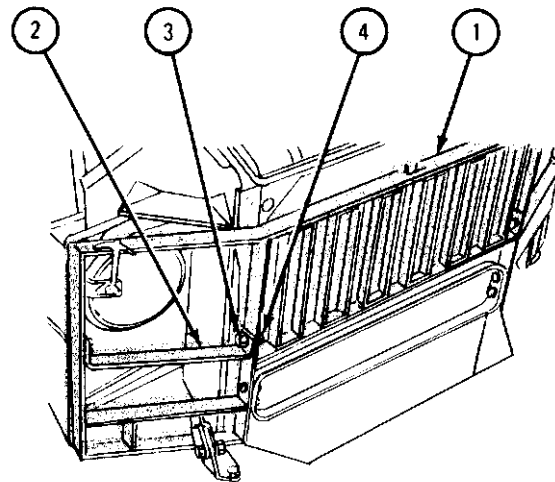

TA 047564

6-5. HOSES AND CLAMPS REMOVAL AND REPLACEMENT.

TOOLS : Flat-tip screwdriver 1/2-inch socket wrench
 9/16-inch wrench (2) 10-inch extension

SUPPLIES : Gasket

PERSONNEL: One

EQUIPMENT CONDITION: Truck parked, engine off, handbrake set.

a. Cooling System Hoses and Clamps.

(1) Preliminary procedures.

(a) Drain cooling system. Refer to para 6-10.

(b) Take off generator belts. Refer to para 6-9.

(2) Removal.

FRAME 1

1. Using screwdriver, loosen two screws (1).
2. Slide two clamps (2) down on hose (3).
3. Using 9/16-inch wrenches, unscrew and take off locknut (4).
4. Pull bolt (5) out of rod end clevis (6).
5. Pull radiator (7) forward at top, just enough to take off hose (3).
6. Pull hose (3) off. Take clamps (2) off hose.

GO TO FRAME 2

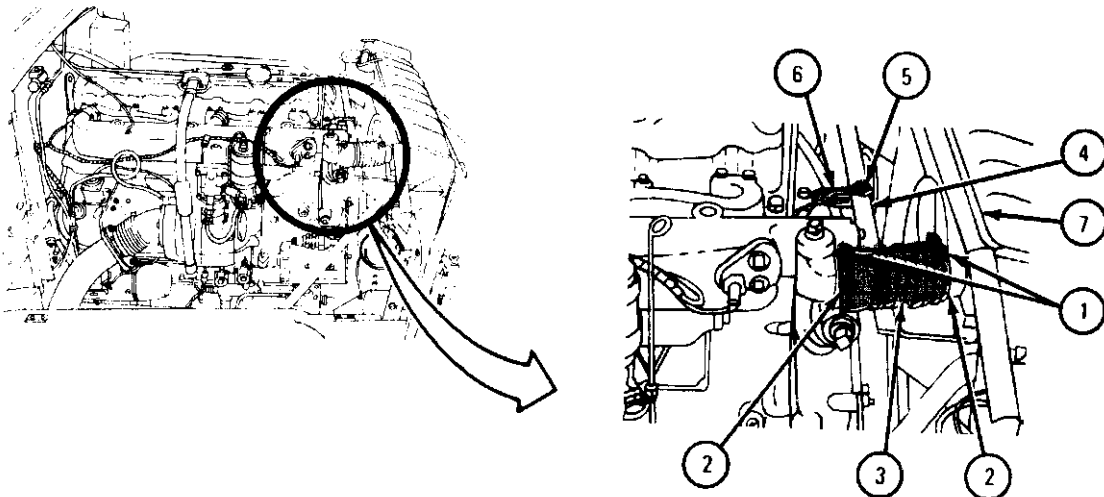

TA 101584

FRAME 2

1. Using 9/16-inch wrench, unscrew and take out two screws (1) with flat washers (2).
2. Using screwdriver, loosen two screws (3) on clamps (4).
3. Slide two clamps (4) down on hose (5).
4. Pull out thermostat housing (6).
5. Take off and throw away gasket (7).
6. Pull off hose (5).
7. Take clamps (4) off hose (5).
8. Using screwdriver, loosen two screws (8) on clamps (9).
9. Slide two clamps (9) down on hose (10).
10. Pull off hose (10) and take off two clamps (9).

END OF TASK

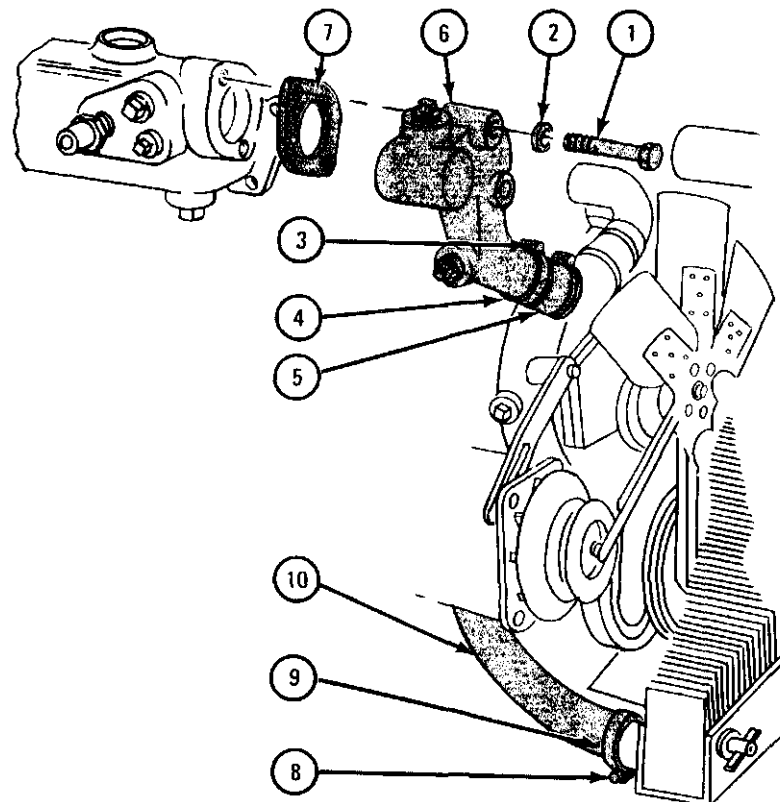

TA 047651

(3) Replacement.

FRAME 1

1. Place two clamps (1) loosely on hose (2).
2. Slip hose (2) onto connector (3) and thermostat housing (4).
3. Slide one clamp (2) to each end of hose (2).
4. Make sure surface of intake manifold flange (5) is clean. Put gasket (6) on flange.
5. Mate thermostat housing (4) with intake manifold flange (5).

GO TO FRAME 2

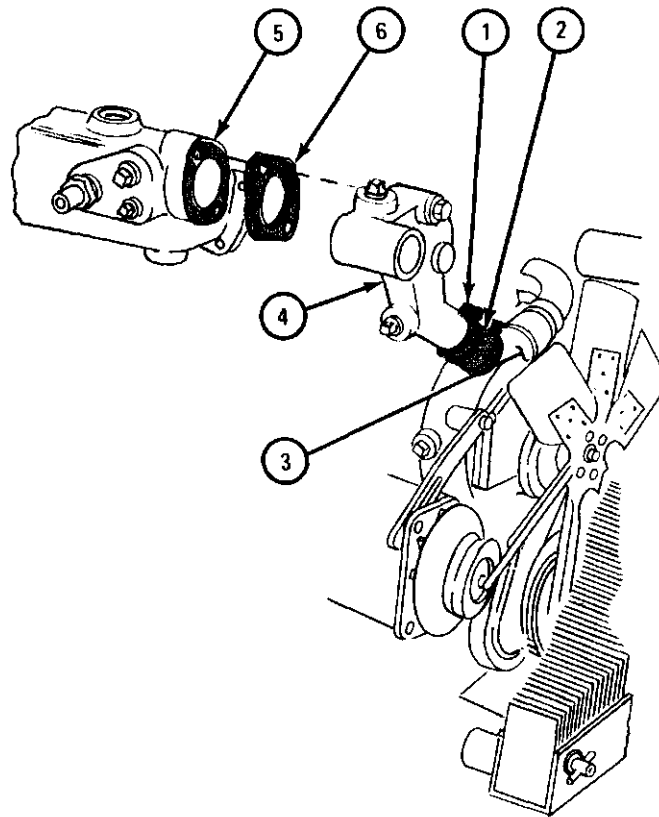

TA 047652

FRAME 2

1. Screw two bolts (1) with lockwashers (2) through thermostat housing (3) into intake manifold (4). Using 9/16-inch wrench, tighten bolts evenly.
2. Using screwdriver, tighten two screws (5).
3. Place two clamps (6) loosely on hose (7).

GO TO FRAME 3

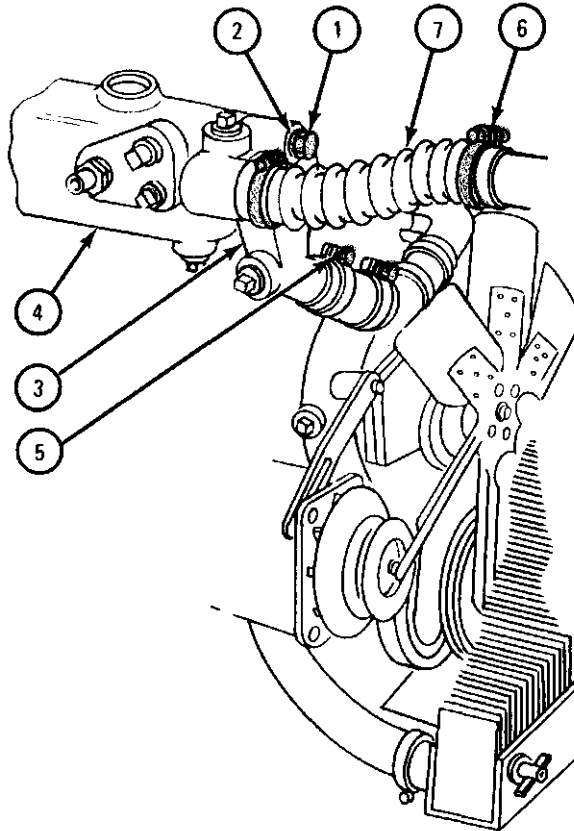

TA 047663

FRAME 3

1. Pull radiator (1) forward just enough to slip hose (2) onto radiator inlet (3).
2. Slip other end of hose (2) onto thermostat housing (4).
3. Slide one clamp (5) to each end of hose (2). Do not tighten screws (6) at this time.

GO TO FRAME 4

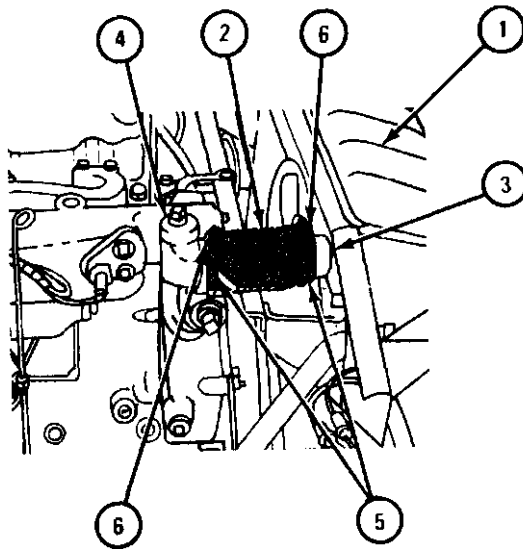

TA 047025

FRAME 4

1. Line up hole in rod end clevis (1) with hole in bracket (2) by moving radiator (3).
2. Put bolt (4) through rod end clevis (1) and bracket (2).
3. Using 9/16-inch wrenches, screw on and tighten locknut (5).
4. Make sure one clamp (6) is at each end of hose (7).
5. Using screwdriver, tighten two screws (8).

GO TO FRAME 5

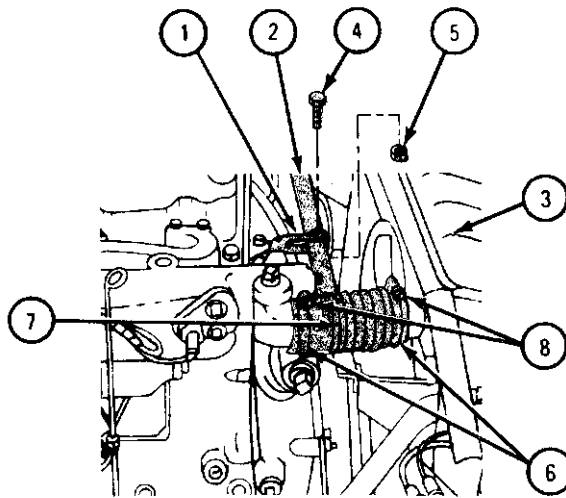

TA 101586

FRAME 5

1. Place two clamps (1) loosely on hose (2).
2. Slip hose (2) onto connectors (3).
3. Slide one clamp (1) to each end of hose (2).
4. Using screwdriver, tighten two screws (4).

NOTE

Follow-on Maintenance Action Required:

1. Put on generator belts. Refer to para 6-9.
2. Fill cooling system. Refer to para 6-10.
3. Check hoses for leakage.

END OF TASK

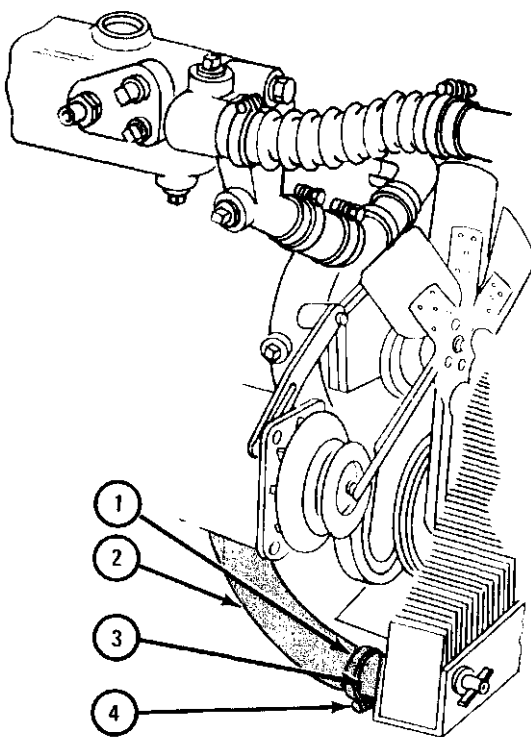

TA 047664

b. Turbocharger System Hoses and Clamps.

(1) Preliminary procedure. Open hood and right side panel. Refer to TM 9-2320-209-10.

(2) Removal.

FRAME 1

1. Using screwdriver, loosen two clamps (1).
2. Using 1/2-inch socket wrench with 10-inch extension, unscrew and take off four nuts (2).
3. Take off elbow (3) and hose (4).
4. Slide two clamps (1) off elbow (3) and hose (4).
5. Take hose (4) from elbow (3).

GO TO FRAME 2

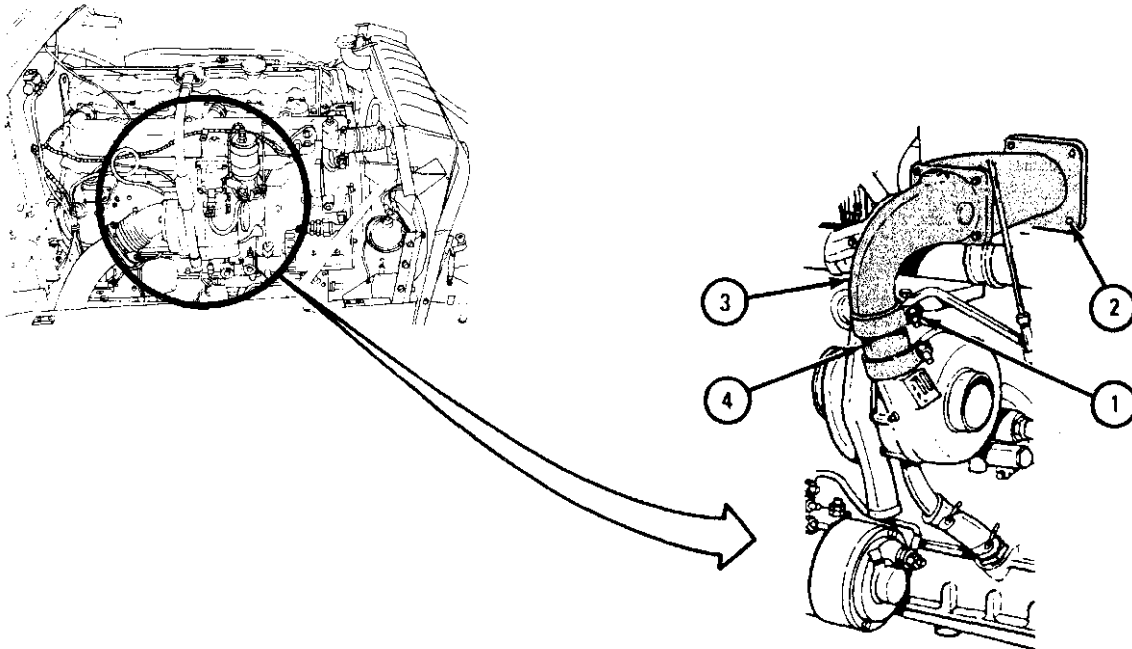

TA 047653

1. Using screwdriver, loosen two screws (1).
2. Slide two clamps (2) down on hose (3).
3. Pull hose (3) off.
4. Take two clamps (2) off hose (3).

END OF TASK

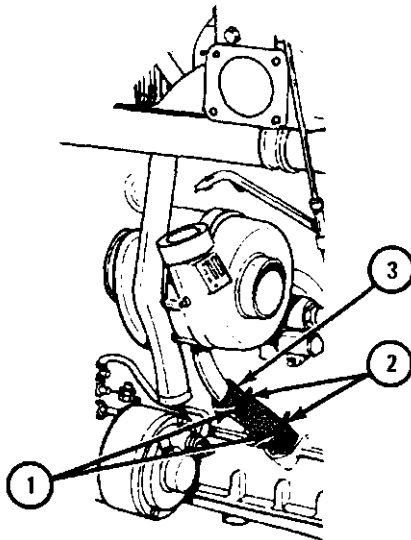

TA 082201

(3) Replacement.

FRAME 1

1. Slide two clamps (1) on hose (2).
2. Put hose (2) in place as shown.
3. Slide two clamps (1) into place as shown.
4. Using screwdriver, tighten two screws (3).

GO TO FRAME 2

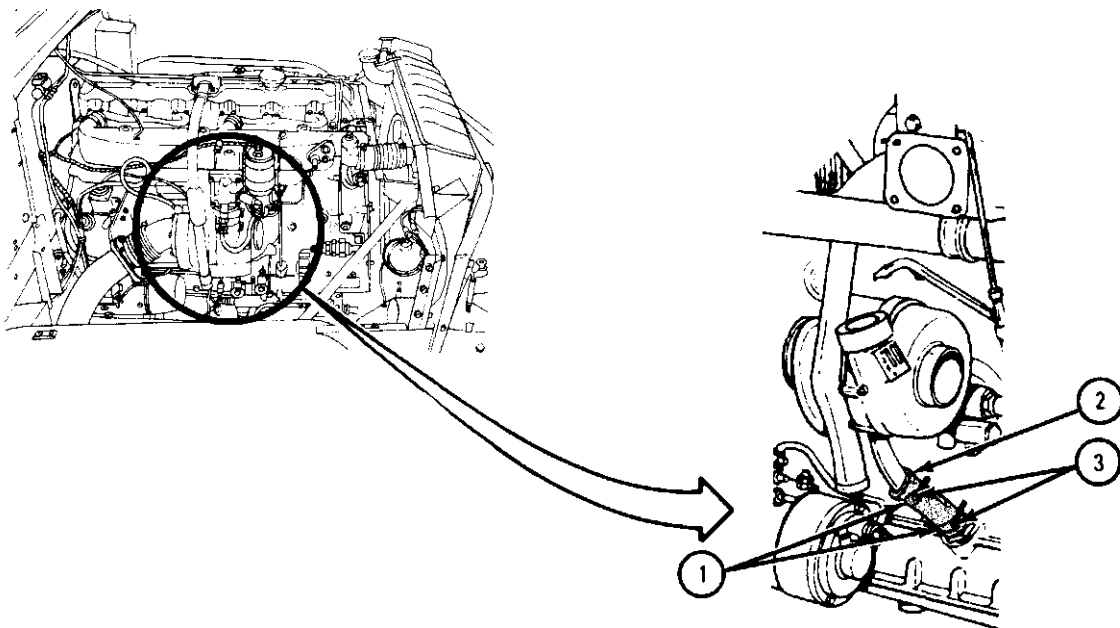

TA 047654

FRAME 2

1. Put hose (1) on elbow (2).
2. Slide two clamps (3) on hose (1) and elbow (2).
3. Put hose (1) and elbow (2) in place as shown.
4. Using 1/2-inch socket wrench with 10-inch extension, screw on and tighten four nuts (4).
5. Using screwdriver, tighten two clamps (3).

NOTE

Follow-on Maintenance Action Required:

Close hood and right side panel. Refer to TM 9-2320-209-10.

END OF TASK

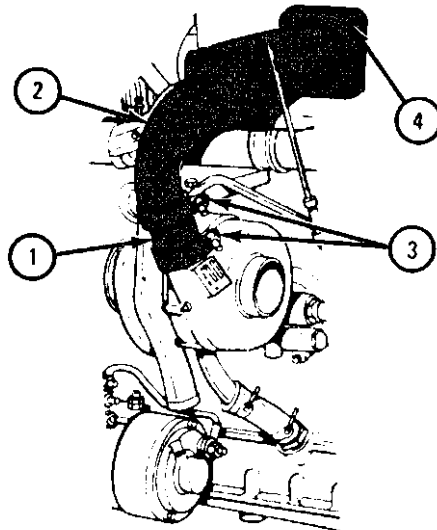

TA 082202

Section III. THERMOSTAT

6-6. THERMOSTAT REMOVAL AND REPLACEMENT.

TOOLS : 9/16-inch open end wrench (2)
Flat-tip screwdriver

SUPPLIES: Solvent, dry cleaning, type II (SD-2), Fed. Spec P-D-680

PERSONNEL: One

EQUIPMENT CONDITION: Truck parked, engine off, handbrake set.

a. Preliminary Procedures.

- (1) Open hood and both side panels. Refer to TM 9-2320-209-10.
- (2) Drain cooling system. Refer to para 6-10.

b. Removal.

<p>FRAME 1</p>	<ol style="list-style-type: none"> 1. Using screwdriver, loosen two screws (1) on two clamps (2). Spread open both clamps and take clamps off hose (3). 2. Using two wrenches, unscrew nut (4) from bolt (5) and take nut off. Pull bolt out of rod end clevis (6). 3. Pull radiator (7) forward at top just enough to take off preformed hose (3). <p>GO TO FRAME 2</p>
<p>TA 085560</p>	

FRAME 2

1. Using 9/16-inch wrench, unscrew two bolts (1). Take bolts with two flat washers (2) out of thermostat housing (3).
2. Using screwdriver, loosen screw (4) on clamp (5).
3. Pull thermostat housing (3) away from intake manifold (6) and from hose (7). Pull gasket (8) away from intake manifold (6) and throw gasket away.

GO TO FRAME 3

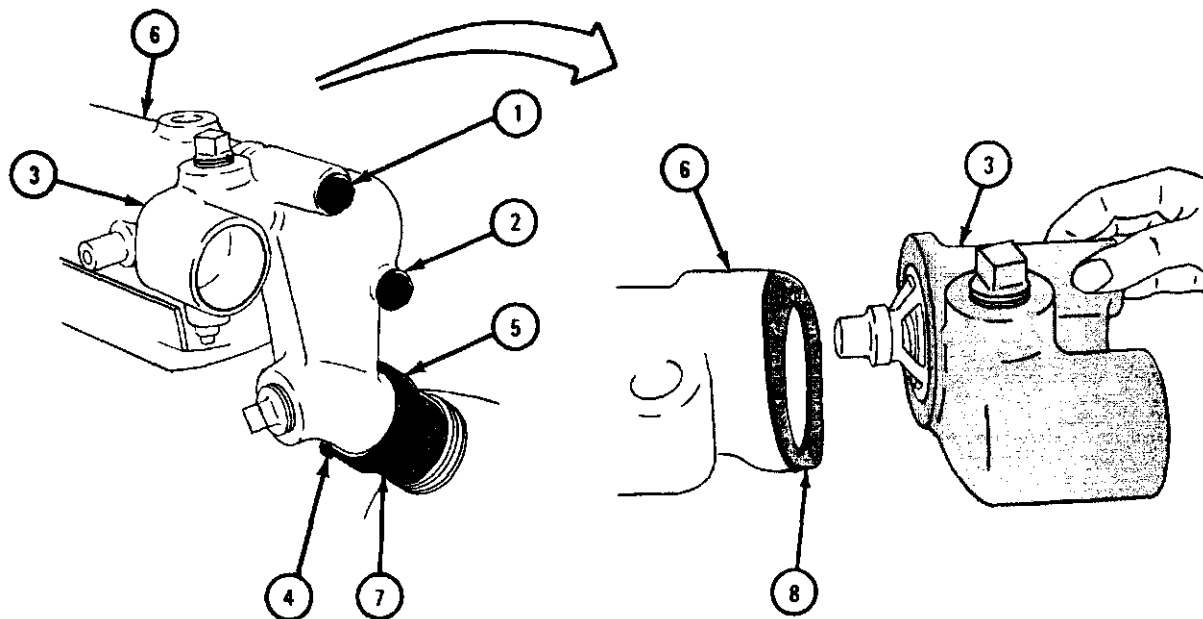

TA 047020

FRAME 3

1. Pull thermostat (1) out of thermostat housing (2).
2. Note position of seal (3) so that you will put it back in the same way. Pull seal out of thermostat housing (2).

END OF TASK

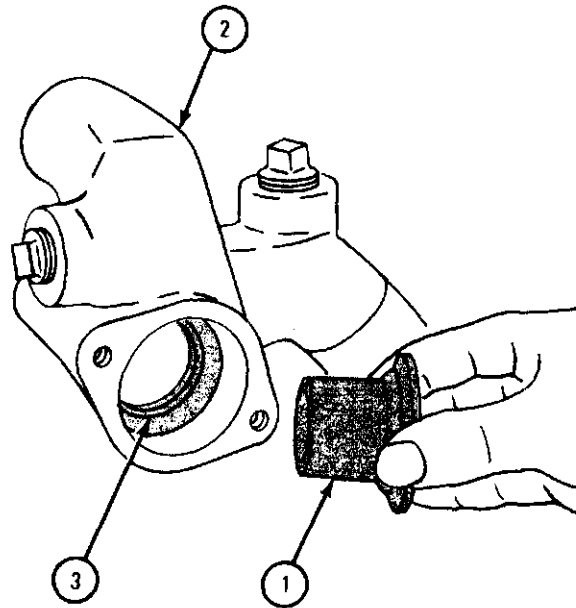

TA 085561

c. Replacement.

FRAME 1

WARNING

Dry cleaning solvent is flammable, Do not use near an open flame. Keep a fire extinguisher nearby when solvent is used. Use only in well-ventilated area. Failure to do this will result in injury to personnel and damage to equipment.

NOTE

Clean thermostat housing (1) using solvent. Make sure surfaces that meet hoses or gaskets are smooth and clean.

1. Put seal (2) into thermostat housing (1) so that lip of seal faces outward toward thermostat (3).
2. Put thermostat (3) into thermostat housing (1) as shown.

GO TO FRAME 2

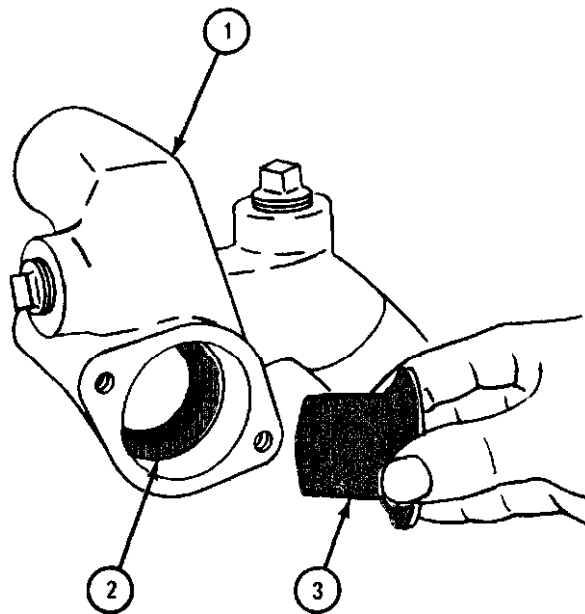

TA 085562

FRAME 2

1. Make sure surface of intake manifold flange (1) is clean. Put gasket (2) on flange.
2. Hold thermostat housing (3) in engine compartment as shown.
3. Join hose (4) to thermostat housing (3) but do not tighten clamp (5).
4. Put thermostat housing (3) against intake manifold flange (1) . Make sure lip (6) of thermostat housing seats in recess (7) of intake manifold flange.

GO TO FRAME 3

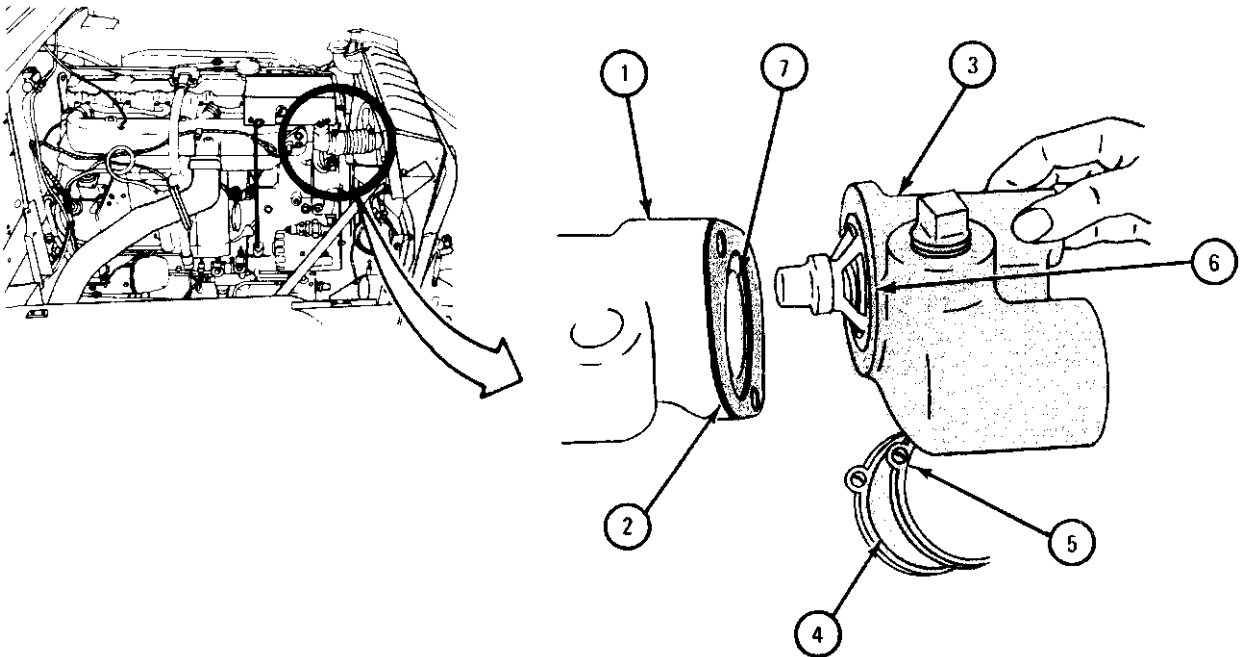

TA 085563

FRAME 3

1. Hold thermostat housing (1) firmly against intake manifold (2).
2. Put two bolts (3) with flat washers (4) through thermostat housing (1) and screw into intake manifold (2). Using 9/16-inch wrench, tighten bolts evenly.
3. Put clamp (5) squarely over hose (6) as shown.
4. Using screwdriver, tighten screw (7) on clamp (5).

GO TO FRAME 4

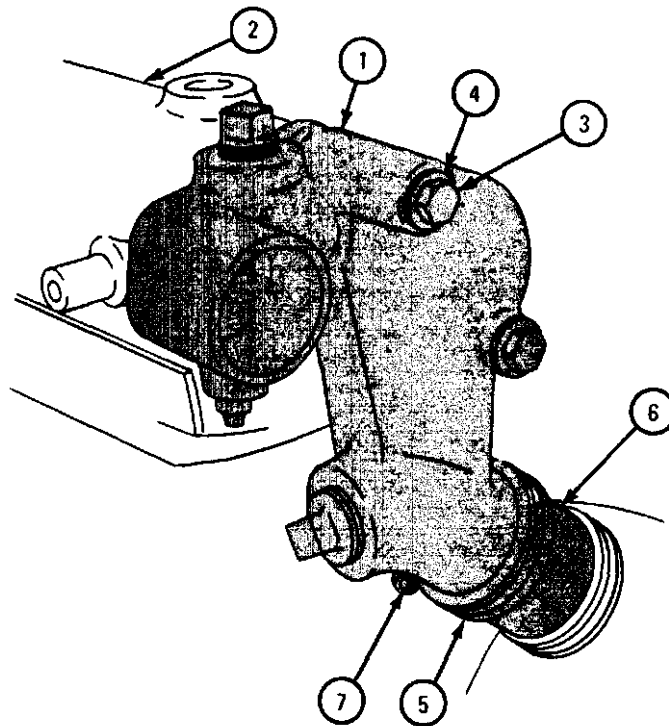

TA 085564

FRAME 4

1. Pull radiator (1) forward just enough to slip preformed hose (2) onto radiator inlet fitting (3).
2. Slip other end of preformed hose (2) on thermostat housing outlet fitting (4).
3. Put two clamps (5) on preformed hose (2) where shown. Do not tighten clamp screws (6) at this time.

GO TO FRAME 5

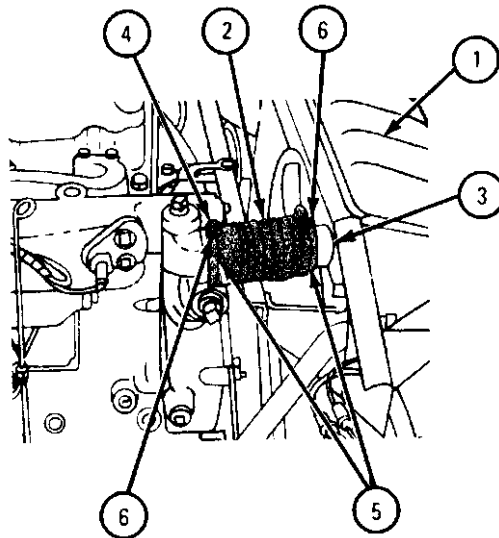

TA 085565

FRAME 5

1. Aline hole in rod end clevis (1) with hole in bracket (2) by moving radiator (3).
2. Put bolt (4) through clevis (1) and bracket (2). Using 9/16-inch wrenches, screw on and tighten locknut (5) on bolt.
3. Make sure clamps (6) are positioned squarely on hose (7). Using screwdriver, tighten two clamp screws (8).

NOTE

Follow-on Maintenance Action Required:

1. Fill cooling system. Refer to para 6-10.
2. Start engine. Refer to TM 9-2320-209-10.
3. Run engine until operating temperature is reached. Check that engine temperature levels off between 160° and 180° as indicated on temperature gage. Check hose fitting on thermostat and radiator for leaks.
4. Stop engine. Refer to TM 9-2320-209-10.
5. Close hood and side panels. Refer to TM 9-2320-209-10.

END OF TASK

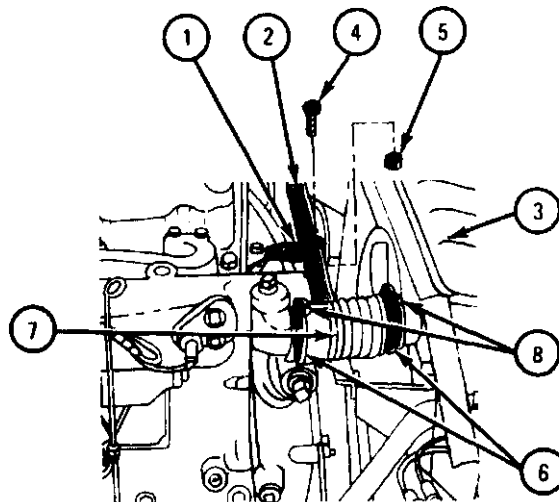

TA 085566

Section IV. WATER PUMP

6-7. WATER PUMP REMOVAL AND REPLACEMENT.

TOOLS : 9/16-inch socket wrench
Flat-tip screwdriver

SUPPLIES : Solvent, dry cleaning, type II (SD-2), Fed. Spec P-D-680

PERSONNEL: One

EQUIPMENT CONDITION : Truck parked, engine off, handbrake set.

a. Preliminary Procedures.

- (1) Open hood and both side panels. Refer to TM 9-2320-209-10.
- (2) Remove radiator. Refer to para 6-3.
- (3) Remove engine cooling fan. Refer to para 6-8.
- (4) Remove fan drive belts. Refer to para 6-9.

b. Removal.

FRAME 1

1. Using screwdriver, loosen two hose clamp screws (1) and slide hose (2) up on thermostat housing (3). Hose should clear water pump outlet (4).
2. Using screwdriver, loosen clamp (5). Slide clamp back on hose (6). Take off hose.
3. Using 9/16-inch wrench, unscrew and take off three bolts and lockwashers (7).
4. Take off water pump (8).

END OF TASK

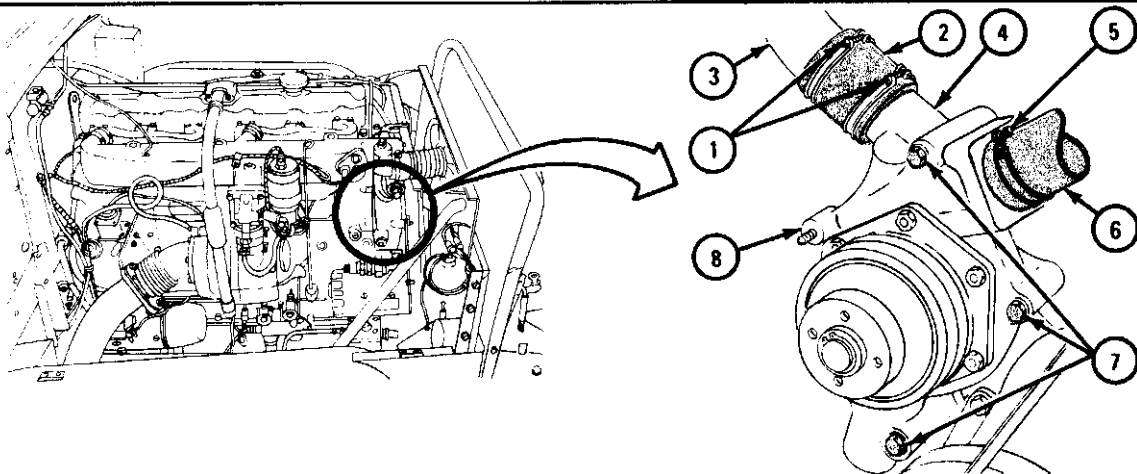

TA 047014

c. Replacement.

FRAME 1

WARNING

Dry cleaning solvent is flammable. Do not use near open flame. Keep a fire extinguisher nearby when working with solvent. Use only in well-ventilated area. Failure to do this will result in injury to personnel and damage to equipment.

NOTE

Before installing water pump, clean pump using solvent. Make sure that all surfaces contacting gaskets or hose are smooth and free of dirt.

1. Place water pump (1) on front of engine block as shown.
2. Put three bolts with lockwashers (2) through water pump mounting holes and using 9/16-inch wrench, tighten bolts.
3. Put hose (3) on water pump (1). Slide clamp (4) into place. Using screwdriver, tighten clamp.
4. Slide hose (5) down from thermostat housing (6) over water pump (1) outlet as shown.
5. Put clamps (7) near ends of hose (5) as shown. Using screwdriver, tighten two screws (8).

GO TO FRAME 2

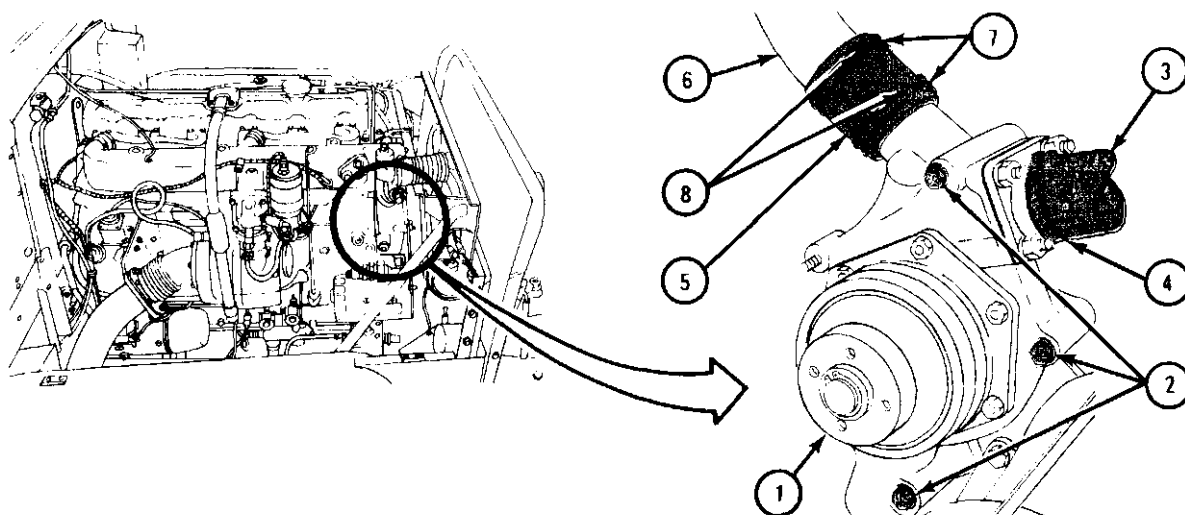

TA 047015

FRAME 2

NOTE

Follow-on Maintenance Action Required:

1. Replace fan drive belts. Refer to para 6-9.
2. Replace engine cooling fan. Refer to para 6-8.
3. Replace radiator. Refer to para 6-3.
4. Start engine and run until operating temperature is reached. Refer to TM 9-2320-209-10. Check hoses for leaks.
5. Close hood and side panels. Refer to TM 9-2320-209-10.

END OF TASK

Section V. FAN ASSEMBLY AND RELATED PARTS

6-8. ENGINE COOLING FAN REMOVAL AND REPLACEMENT.

TOOLS : 1/2-inch socket wrench
Flat-tip screwdriver

SUPPLIES: None

PERSONNEL: One

EQUIPMENT CONDITION: Truck parked, engine off, handbrake set.

a. Preliminary Procedures.

- (1) Open hood and both side panels. Refer to TM 9-2320-209-10.
- (2) Remove radiator. Refer to para 6-3.

b. Removal.

FRAME 1

NOTE

Hold fan (1) while removing bolts.

1. Using 1/2-inch wrench, unscrew and take out four bolts and lockwashers (2).
2. Lift off fan (1) .

END OF TASK

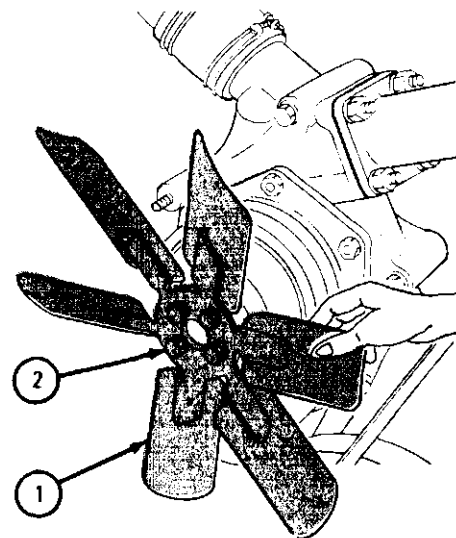
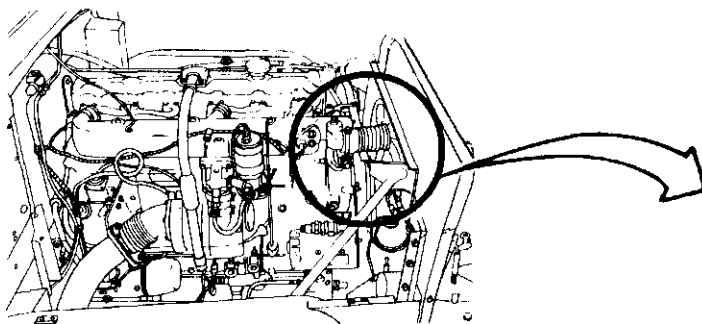

TA 047016

c. Replacement.**FRAME 1**

1. Place fan (1) on hub of drive assembly (2) and align four holes.

NOTE

Hold fan while tightening bolts (3).

2. Screw four bolts (3) with lockwashers (4) through fan (1) mounting holes into drive assembly (2).
3. Using 1/2-inch wrench, tighten four bolts (3).

NOTE

Follow-on Maintenance Action Required:

1. Replace radiator. Refer to para 6-3.
2. Close hood and side panels. Refer to TM 9-2320-209-10.

END OF TASK

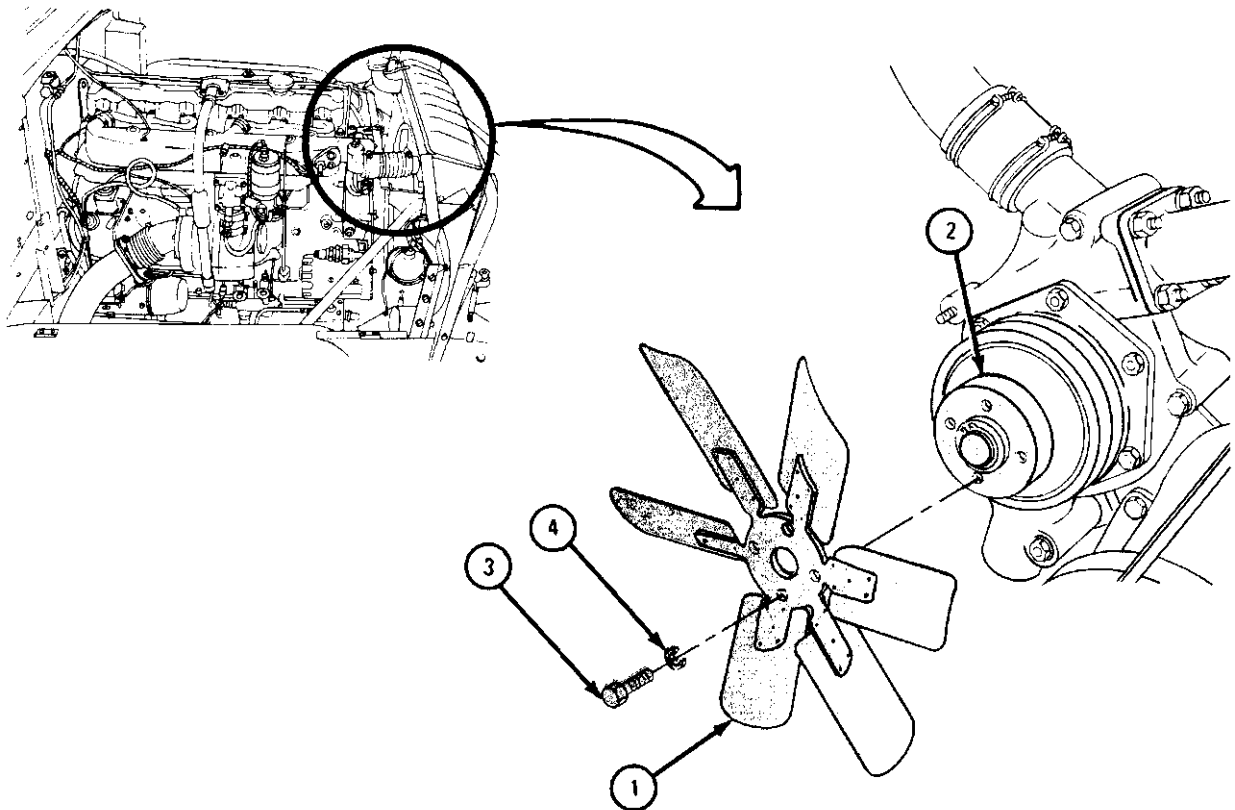

TA 047018

6-9. FAN DRIVE BELTS REMOVAL, REPLACEMENT, AND ADJUSTMENT.

TOOLS: 9/16-inch wrench
30-inch bar
Spring scale
Ruler
Straight edge

SUPPLIES: None

PERSONNEL: One

EQUIPMENT CONDITION: Truck parked, engine off, handbrake set.

- a. Preliminary Procedure. Open hood. Refer to TM 9-2320-209-10,
- b. Removal.

FRAME 1

1. Using 9/16-inch wrench, loosen capscrew (1), and washer (2) that holds adjusting arm (3) to generator (4).

GO TO FRAME 2

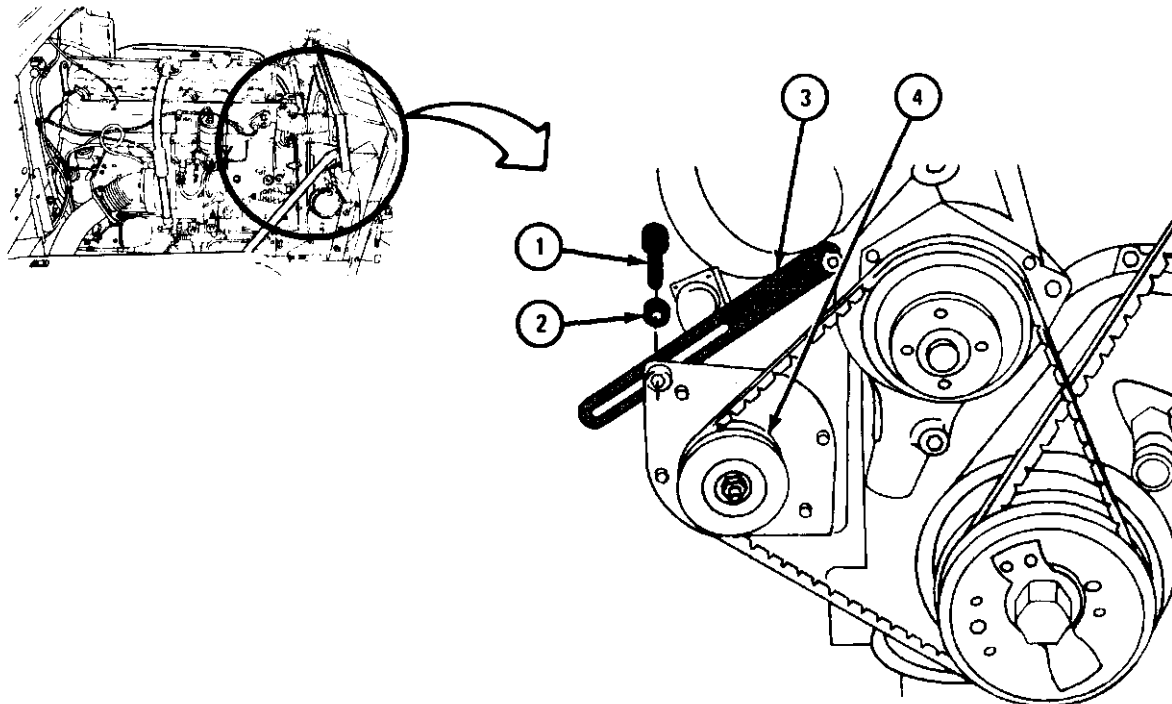

TA 047636

FRAME 2

1. Push generator (1) toward engine. Take off two fan drive belts (2) from generator pulley (3), coolant pump pulley (4), and crankshaft pulley (5).

END OF TASK

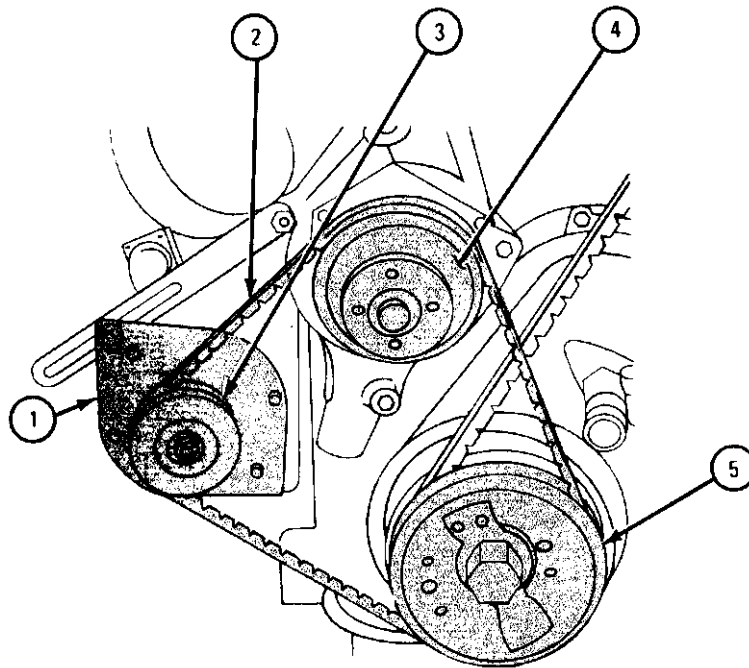

TA 047637

c. Replacement and Adjustment.

FRAME 1

NOTE

Fan drive belts (1) must always be replaced as a pair.

1. Place two fan drive belts (1) over coolant pump pulley (2), crankshaft pulley (3), and generator pulley (4).
2. Hand tighten capscrew (5) with washer (6).

GO TO FRAME 2

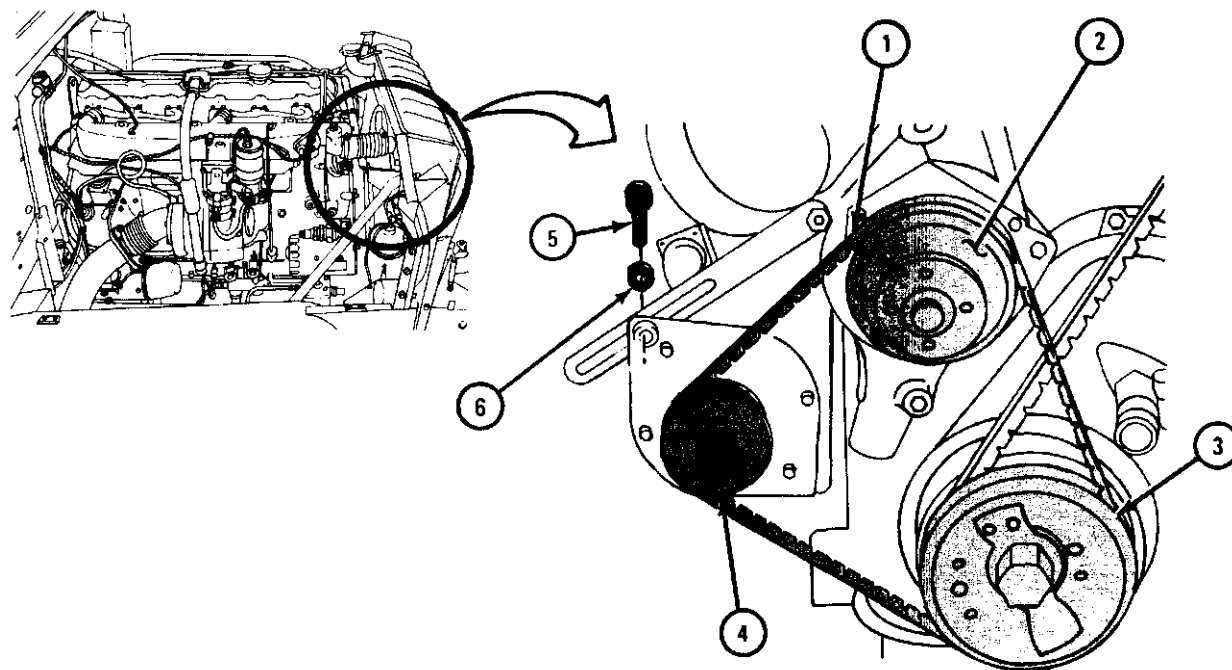

TA 047638

1. Place end of 30-inch bar (1) between crankcase (2) and generator (3).
- GO TO FRAME 3

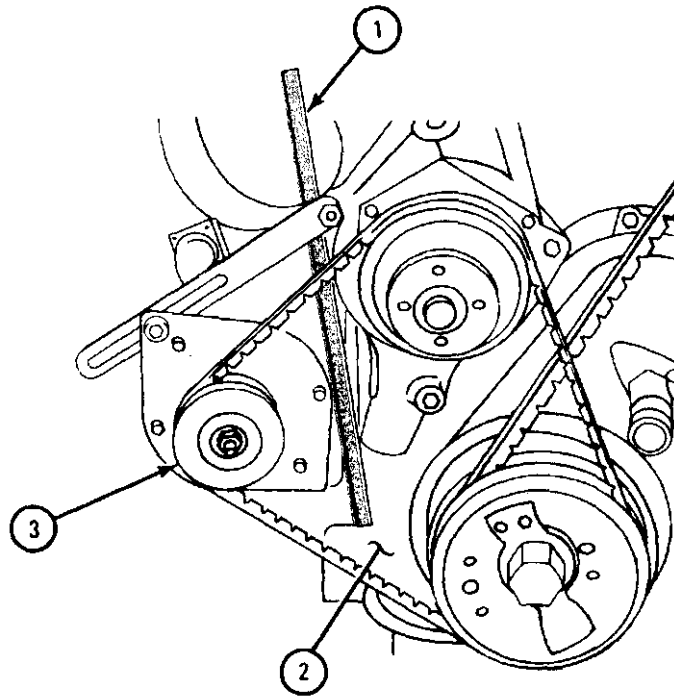

TA 047639

FRAME 3

1. Using spring scale (1), pull upper end of bar (2) with force of 50 pounds and using 9/16-inch wrench, tighten capscrew (3). Take out bar.
2. Push on belts (4) at point midway between coolant pump pulley (5) and generator pulley (6). Belt should give about 3/4-inch at this point.

NOTE

Follow-on Maintenance Action Required:

Close hood. Refer to TM 9-2320-209-10.

END OF TASK

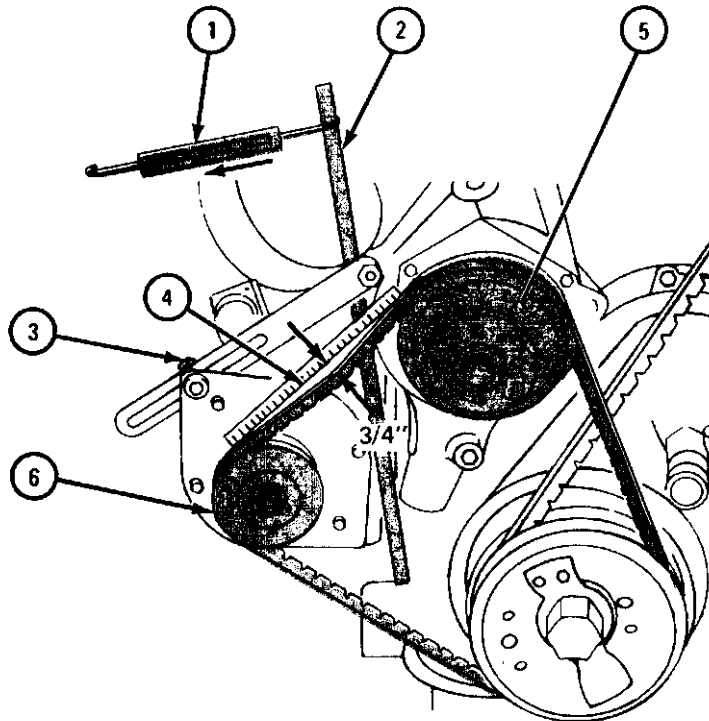

TA 047640

6-10. COOLING SYSTEM SERVICE.

TOOLS : 9/16-inch wrench (2)
6-inch pliers
Scraper
Flat-tip screwdriver
Flushing gun
5-gallon container (2)

SUPPLIES : Cleaning kit (2)
Preformed hose
Coolant
Compressed air source, 30 psi max
Heavy cloth
Rubber gloves
Thermostat housing gasket

PERSONNEL : One

EQUIPMENT CONDITION : Truck parked, engine off and cool, handbrake set.

Preliminary Procedure. Open hood and right side panel. Refer to
TM 9-2320-209-10.

b. Draining.

FRAME 1

WARNING

Do not open filler cap (1) if engine is hot. Pressure will blow out scalding fluid and vapor. Personnel can be badly burned.

1. Press down and turn filler cap (1) all the way to left and lift it off.
2. Put containers under engine block drain cock (2) and radiator drain cock (3). Using pliers, turn two drain cocks to left and let coolant drain into two containers.
3. When all coolant has drained out, turn two drain cocks (2 and 3) to right to close them.
4. Empty coolant in approved disposal area.

END OF TASK

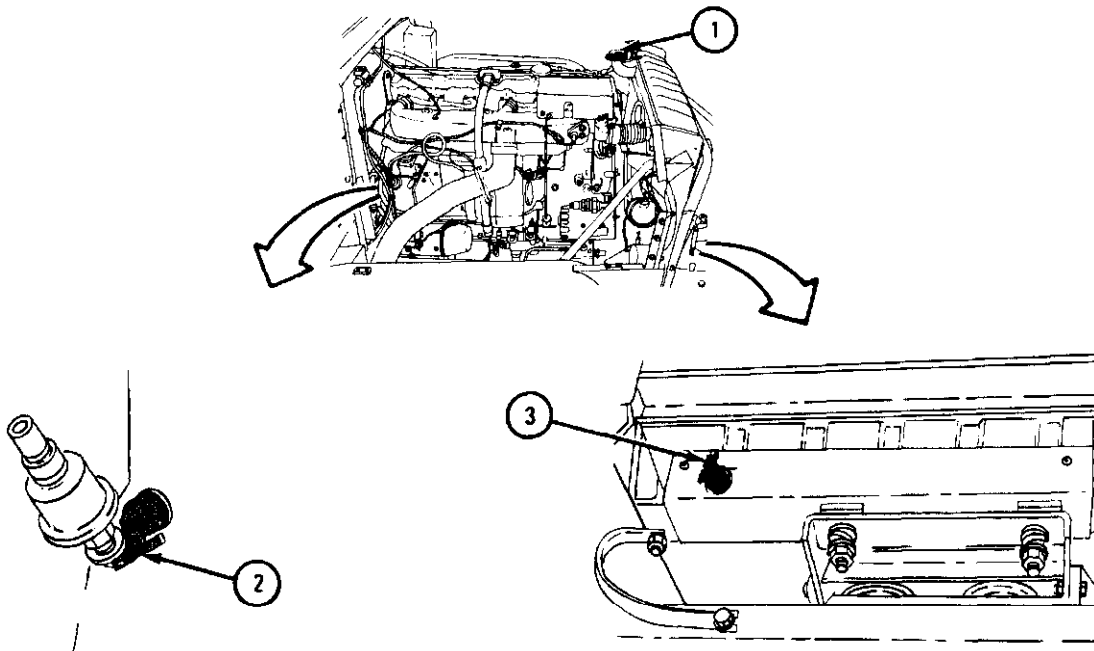

TA 083303

c. Cleaning.**FRAME 1**

1. Fill engine cooling system with clean water to within two inches of overflow.
2. Start engine. Refer to TM 9-2320-209-10.

NOTE

Put cardboard in front of radiator to raise engine temperature if needed, but do not let coolant boil.

3. Run engine at 650 rpm to 700 rpm until engine temperature reaches 160°F to 180°F . Let it run for at least 10 minutes.

WARNING

Use rubber gloves when working with cleaning compound. Do not spill cleaning compound on skin, clothing or truck. Cleaning compound contains strong acid and will cause serious burns to personnel and damage to equipment.

NOTE

Use two bags of oxalic acid and two bottles of aluminum chloride.

4. Slowly pour cleaning compound into radiator filler tube (1) .
5. Put on radiator filler cap (2) and press down and turn it all the way to the right .

GO TO FRAME 2

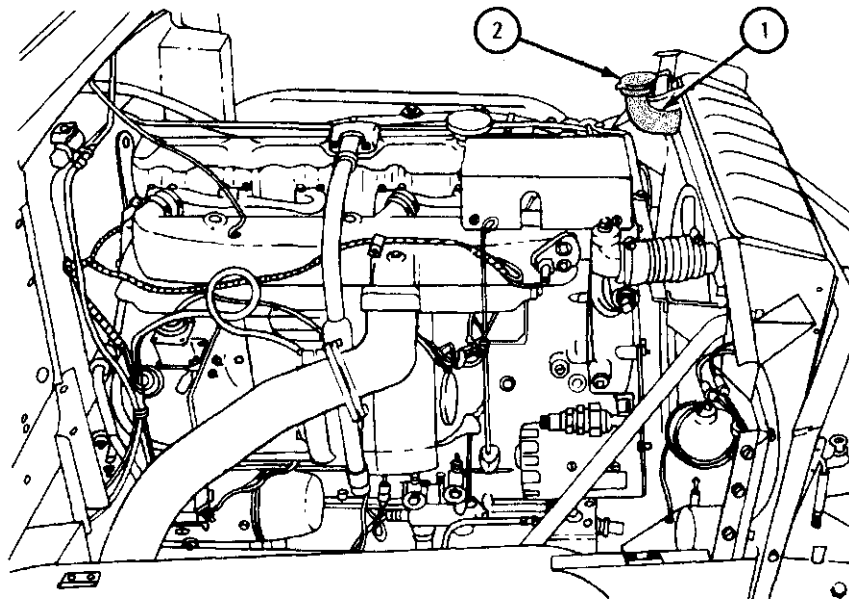

TA 083304

FRAME 2

1. Run engine for 25 minutes.
2. Stop engine. Refer to TM 9-2320-209-10.

WARNING

Do not take off filler cap (1) before pressure has been let out. Pressure will blow out scalding fluid and vapor. Personnel can be badly burned.

3. Put heavy cloth over radiator filler cap (1). Press down and turn filler cap slowly to the left to the first stop. Let all pressure out of cooling system.
4. Press down and turn filler cap (1) all the way to the left and lift it off.

GO TO FRAME 3

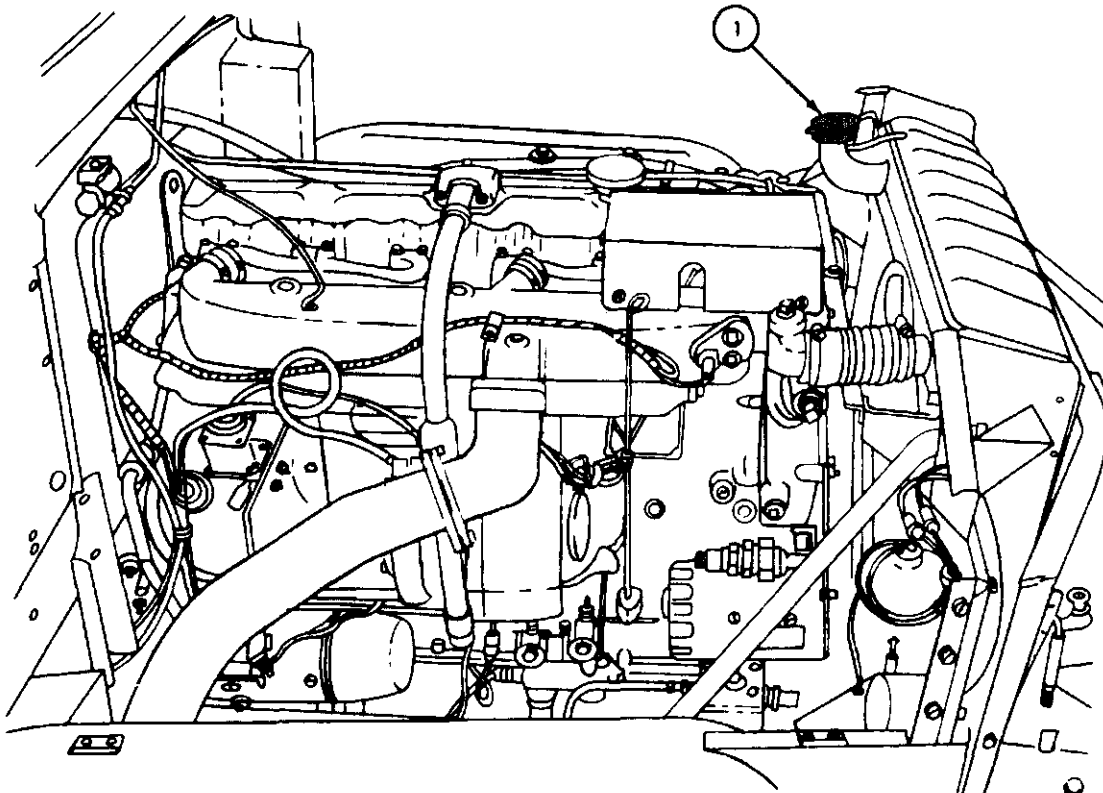

TA 083305

FRAME 3

WARNING

Use rubber gloves when working with cleaning solution. Do not spill cleaning solution on skin, clothing or truck paint. Cleaning solution contains strong acid and will cause serious burns to personnel and damage to equipment.

1. Put containers under engine block drain cock (1) and radiator drain cock (2). Turn two drain cocks to left and let cleaning solution drain into two containers.
2. When all cleaning solution has drained out, turn two drain cocks (1 and 2) to right to close them.
3. Empty cleaning solution in approved disposal area.

END OF TASK

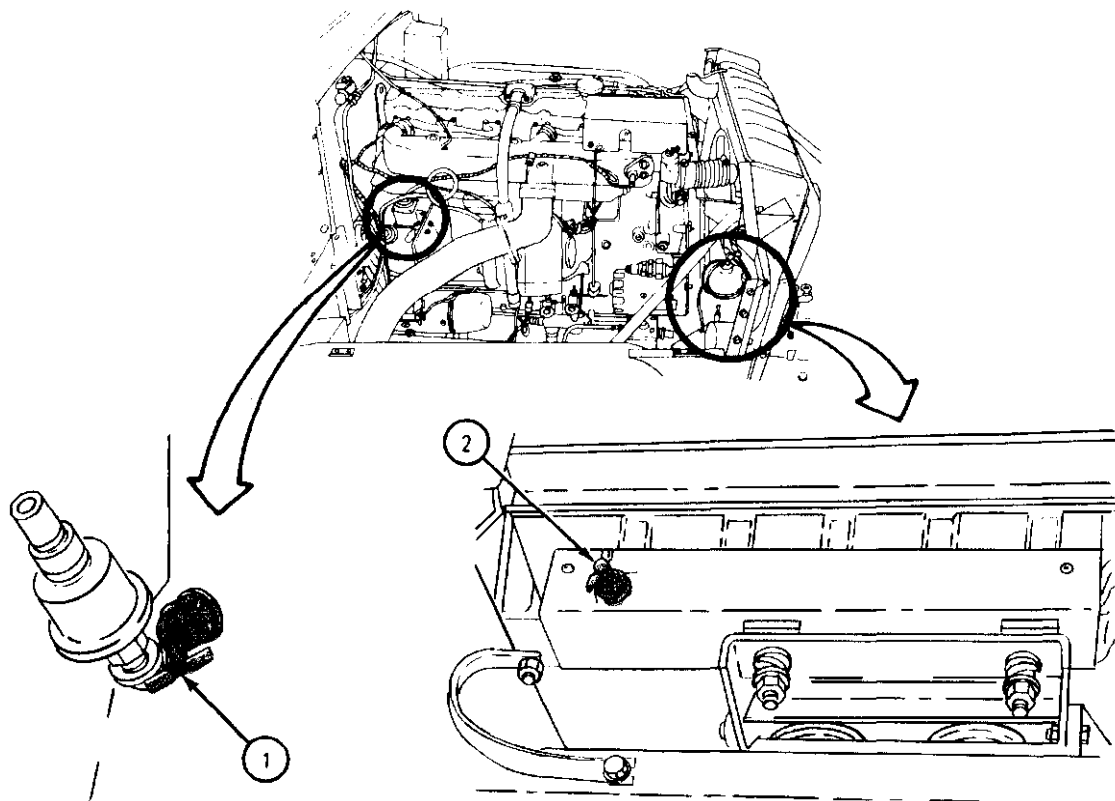

TA 083306

d. Flushing.

FRAME 1

1. Using screwdriver, loosen two screws (1) on two clamps (2). Spread both clamps and take clamps off preformed hose (3).
2. Using 9/16-inch wrenches, unscrew and take off nut (4) from bolt (5). Pull bolt out of rod end clevis (6).
3. Pull top of radiator (7) forward just enough to take off preformed hose (3).

GO TO FRAME 2

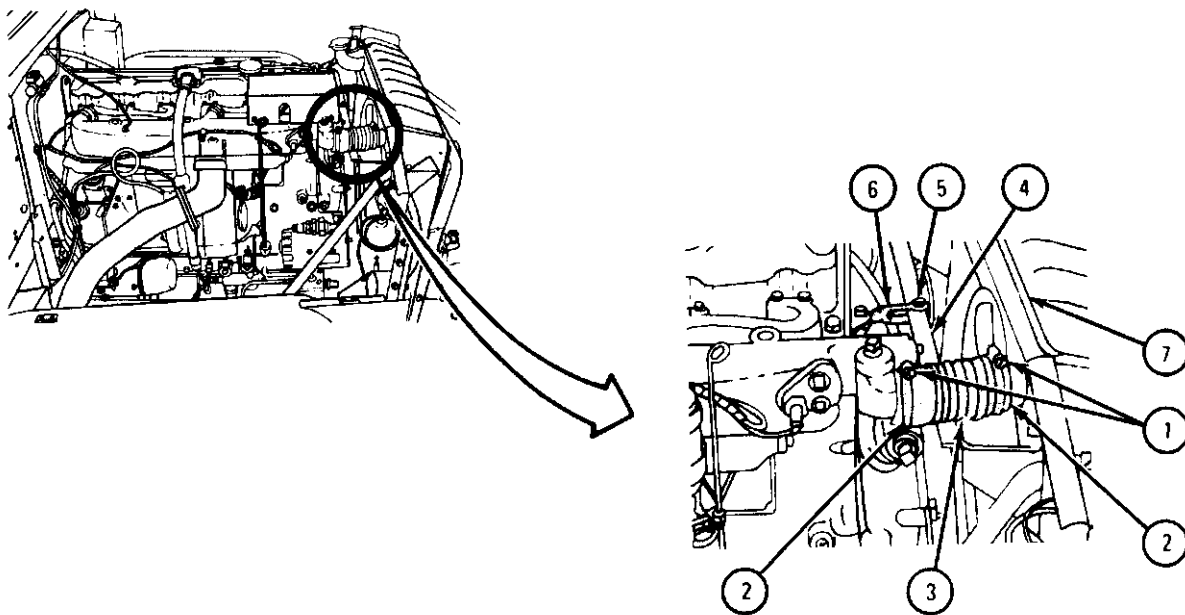

TA 086802

FRAME 2

1. Using 9/16-inch wrench, unscrew two bolts (1). Take bolts with two flat washers (2) out of thermostat housing (3).
2. Using screwdriver, loosen screw (4) on clamp (5).
3. Pull thermostat housing (3) away from intake manifold (6) and from hose (7).
4. Take out thermostat housing (3).

GO TO FRAME 3

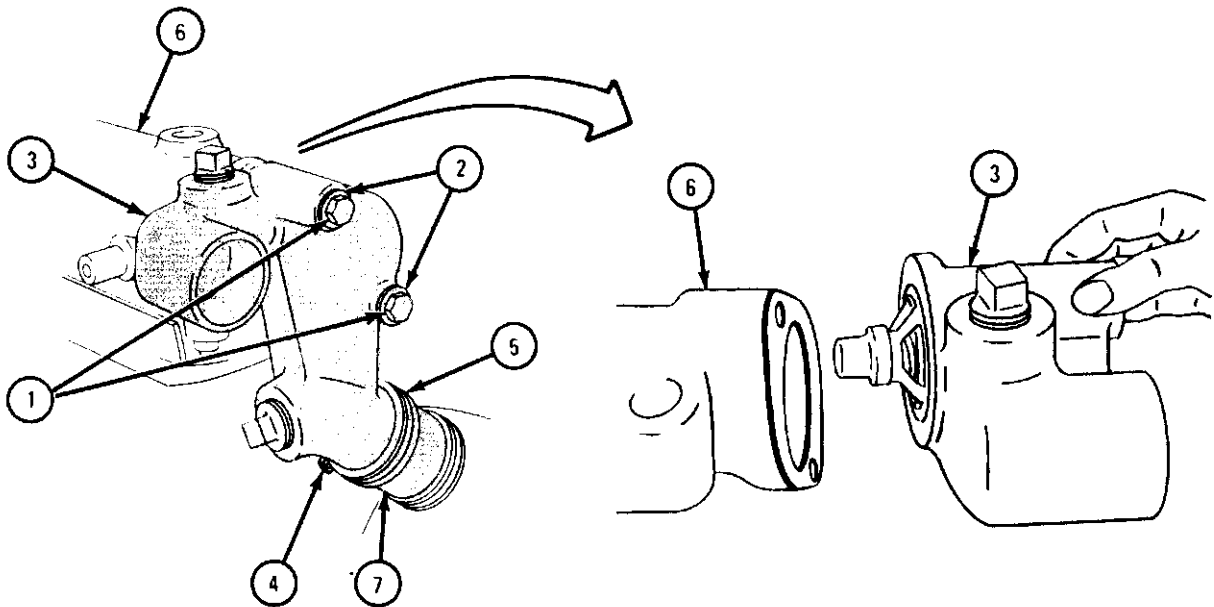

TA 083310

FRAME 3

1. Pull thermostat (1) out of thermostat housing (2).
2. Note position of seal (3) so that it will be put back the same way. Pull seal out of thermostat housing (2).

GO TO FRAME 4

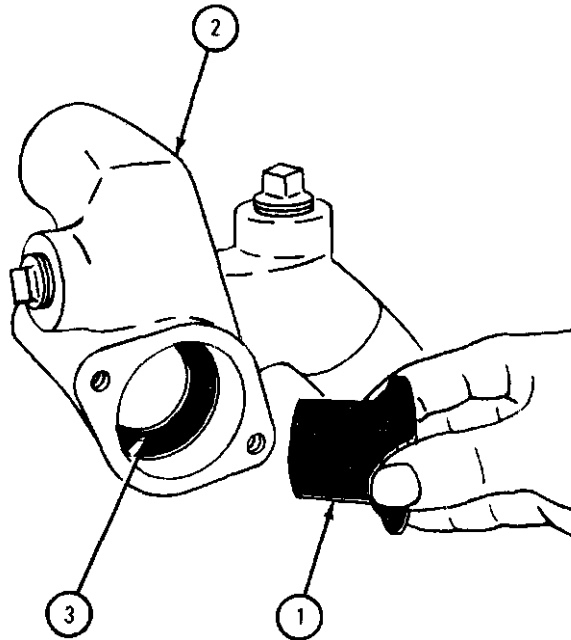

TA 047021

FRAME 4

1. Join hose (1) to thermostat housing (2), but do not tighten clamp (3).
2. Put thermostat housing (2) against intake manifold flange (4). Make sure lip (5) of thermostat housing seats in recess (6) of intake manifold flange.

GO TO FRAME 5

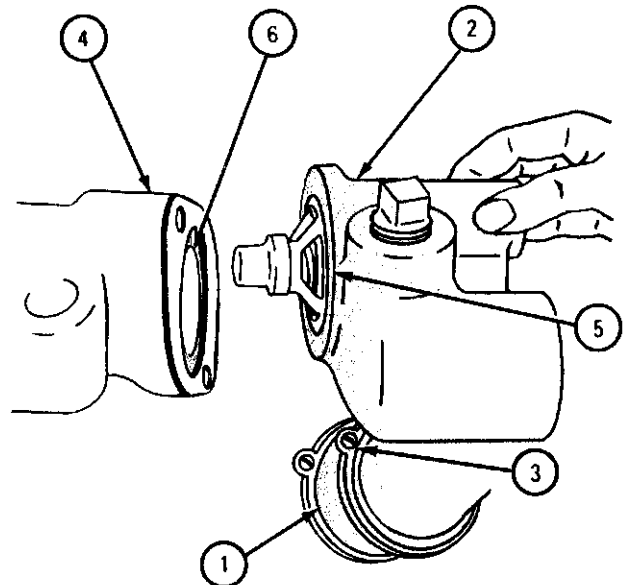
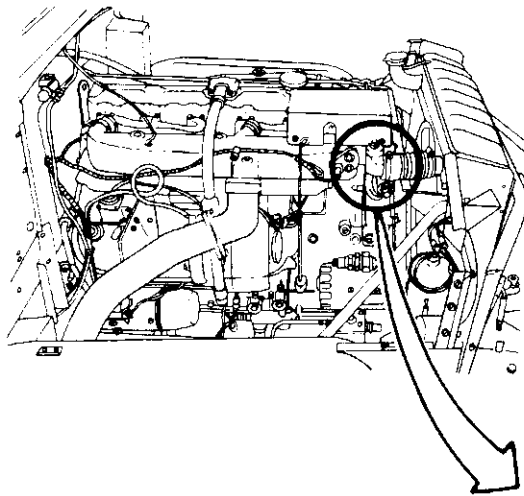

TA 083309

FRAME 5

1. Hold thermostat housing (1) firmly against intake manifold (2).
2. Screw in two bolts (3) with flat washers (4) through thermostat housing (1) and screw into intake manifold (2). Using 9/16-inch wrench, tighten bolts evenly.
3. Put clamp (5) squarely over hose (6) as shown.
4. Using screwdriver, tighten screw (7) on clamp (5).

GO TO FRAME 6

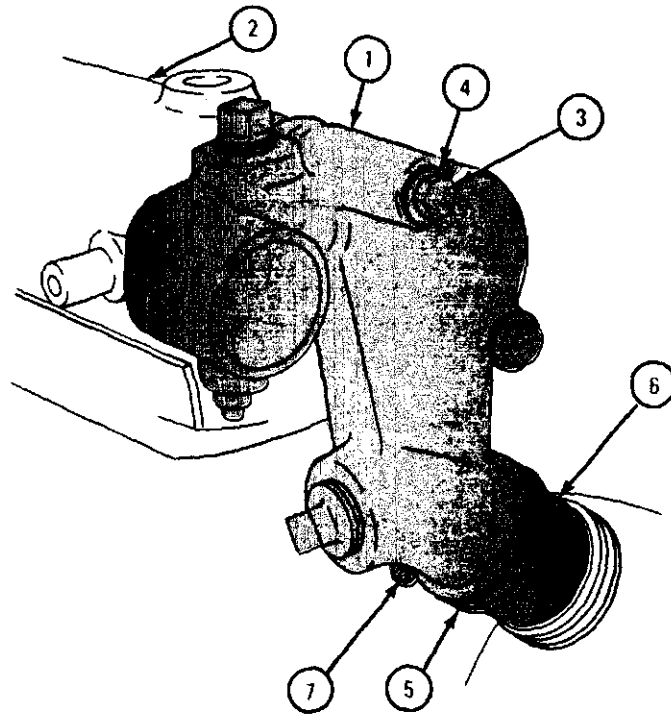

TA 047024

FRAME 6

1. Hook up flushing gun (1) to air and water supplies.
2. Slide two clamps (2) onto preformed hose (3).
3. Slide one end of preformed hose (3) onto flushing gun (1) and other end of hose onto thermostat housing (4).
4. Using screwdriver, tighten two screws (5).
5. Using flushing gun (1) fill engine with water.

GO TO FRAME 7

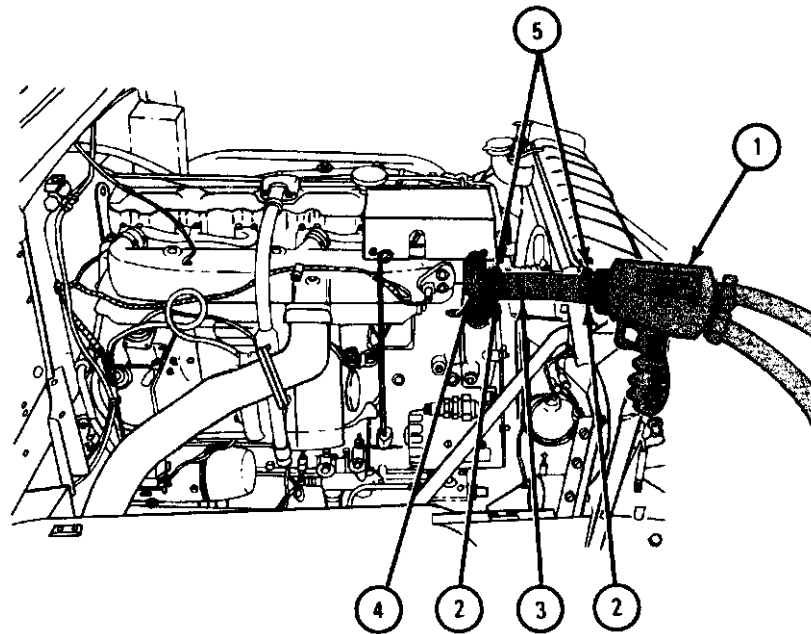

TA 083307

FRAME 7

CAUTION

Do not use more than 10 psi of air pressure. High air pressure may damage radiator.

1. Put container under engine block drain cock (1). Turn drain cock to left to open it.
2. Using flushing gun (2) , turn on air supply and slowly increase air pressure. Let air pressure push out all water.
3. Do frames 6 and 7 again until water from drain cock (1) comes out clean.
4. Using screwdriver, loosen screws (3) and take out flushing gun (2) with hose (4).
5. Turn drain cock (1) to right to close it.

GO TO FRAME 8

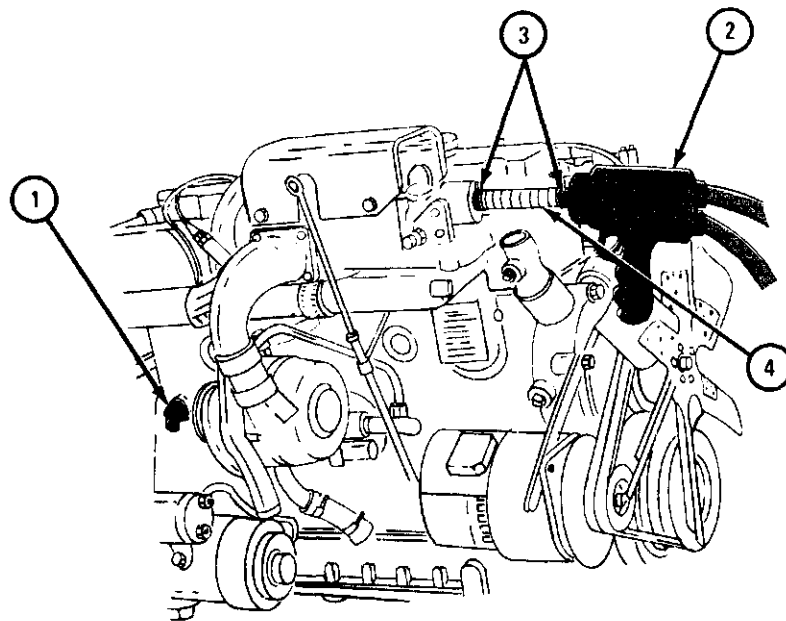

TA 083308

FRAME 8

1. Using 9/16-inch wrench, unscrew two bolts (1). Take bolts with two flat washers (2) out of thermostat housing (3).
2. Using screwdriver, loosen screw (4) on clamp (5).
3. Pull thermostat housing (3) away from intake manifold (6) and from hose (7). Pull gasket (8) away from intake manifold (6) and throw gasket away.
4. Take out thermostat housing (3).
5. Using scraper, clean all gasket material from thermostat housing (3) and intake manifold (6).

GO TO FRAME 9

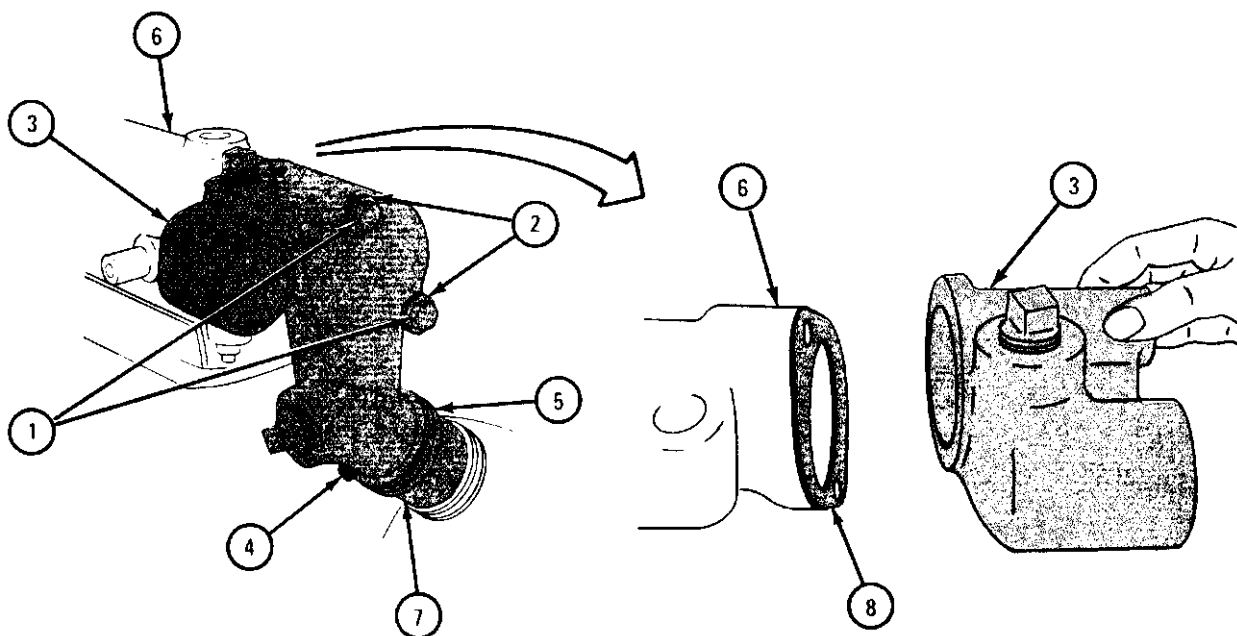

TA 084108

FRAME 9

WARNING

Dry cleaning solvent is flammable. Do not use near an open flame. Keep a fire extinguisher nearby when solvent is used. Use only in well-ventilated places. Failure to do this may result in injury to personnel and damage to equipment.

1. Using solvent , clean surfaces that mate hoses or gaskets so they are smooth and clean.
2. Put seal (1) into thermostat housing (2) so that lip of seal faces outward toward thermostat (3).
3. Put thermostat (3) into thermostat housing (2) as shown.

GO TO FRAME 10

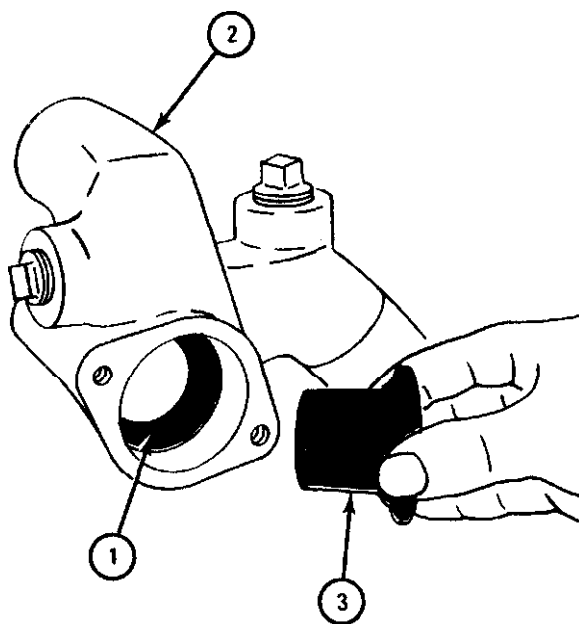

TA 047022

FRAME 10

1. Make sure surface of intake manifold flange (1) is clean. Put gasket (2) on flange.
2. Hold thermostat housing (3) in engine compartment as shown.
3. Join hose (4) to thermostat housing (3), but do not tighten clamp (5).
4. Put thermostat housing (3) against intake manifold flange (1). Make sure lip (6) of thermostat housing seats in recess (7) of intake manifold flange.

GO TO FRAME 11

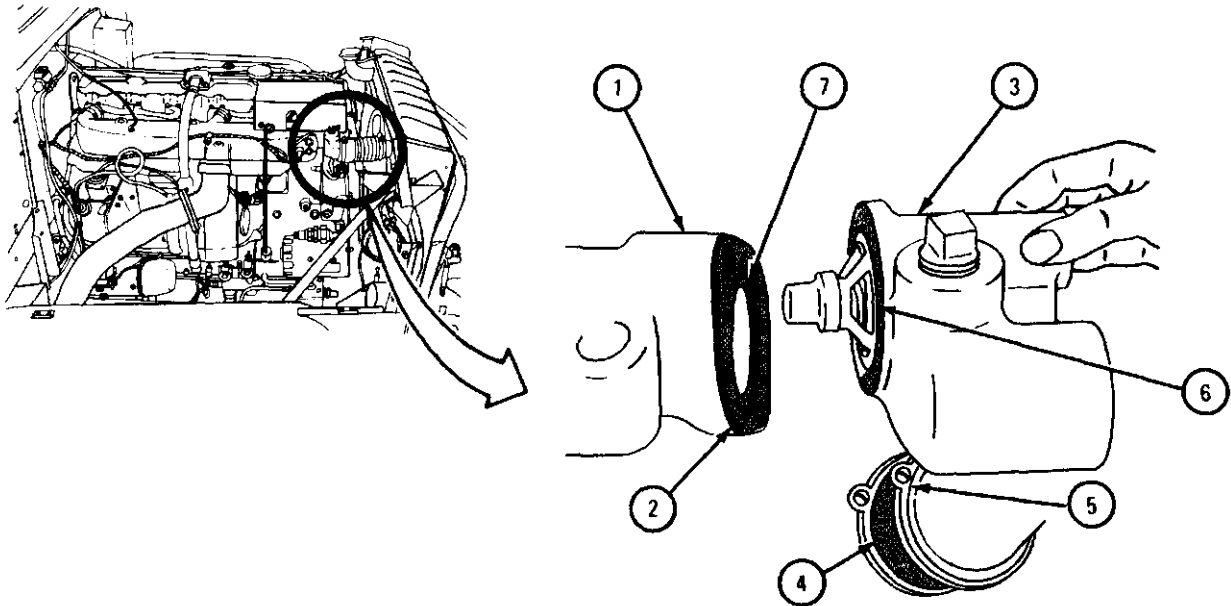

TA 047023

FRAME 11

1. Hold thermostat housing (1) firmly against intake manifold (2).
2. Screw in two bolts (3) with flat washers (4) through thermostat housing (1) and into intake manifold (2). Using 9/16-inch Wrench, tighten bolts evenly.
3. Put clamp (5) squarely over hose (6) as shown.
4. Using screwdriver, tighten screw (7) on clamp (5).

GO TO FRAME 12

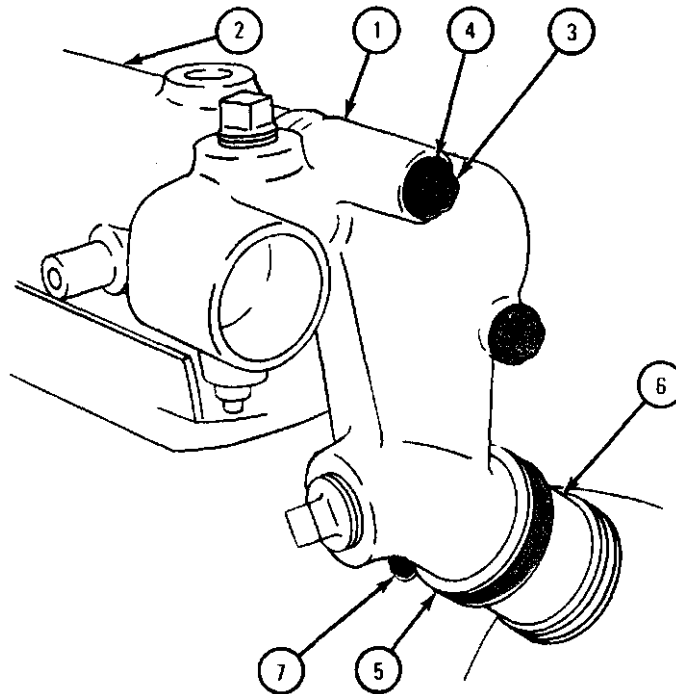

TA 047024

FRAME 12

1. Pull top of radiator (1) forward just enough to slip preformed hose (2) onto radiator inlet fitting (3) .
2. Slip other end of preformed hose (2) on thermostat housing outlet fitting (4).
3. Put two clamps (5) on preformed hose (2) as shown. Do not tighten clamp screws (6) at this time.

GO TO FRAME 13

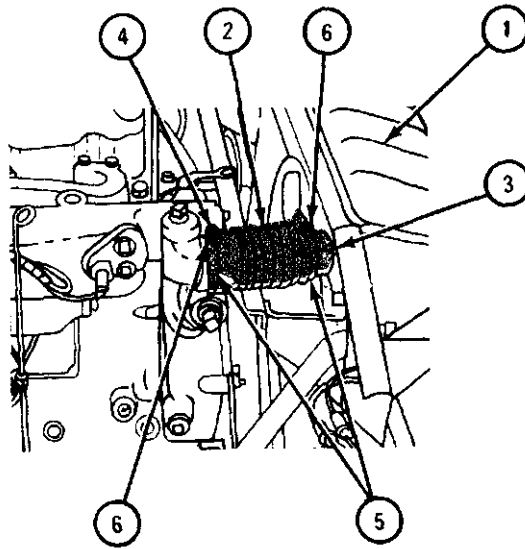

TA 047025

FRAME 13

1. Aline hole in rod end clevis (1) with hole in bracket (2) by moving radiator (3).
2. Put bolt (4) through clevis (1) and bracket (2). Using 9/16-inch wrenches, screw on and tighten locknut (5) on bolt.
3. Make sure clamps (6) are positioned squarely on hose (7). Using screwdriver, tighten two clamp screws (8).

END OF TASK

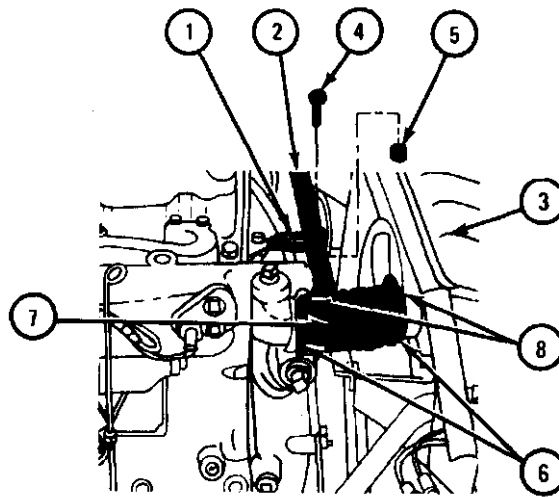

TA 047026

e. Neutralization.

FRAME 1

NOTE

Use two bottles of sodium silicate.

1. Fill engine cooling system with water.
2. Start engine and let it run until engine temperature is 160°F to 180°F. Refer to TM 9-2320-209-10.
3. Slowly pour neutralizer solution into filler tube (1).
4. Put on filler cap (2) and press down and turn it all the way to the right.

GO TO FRAME 2

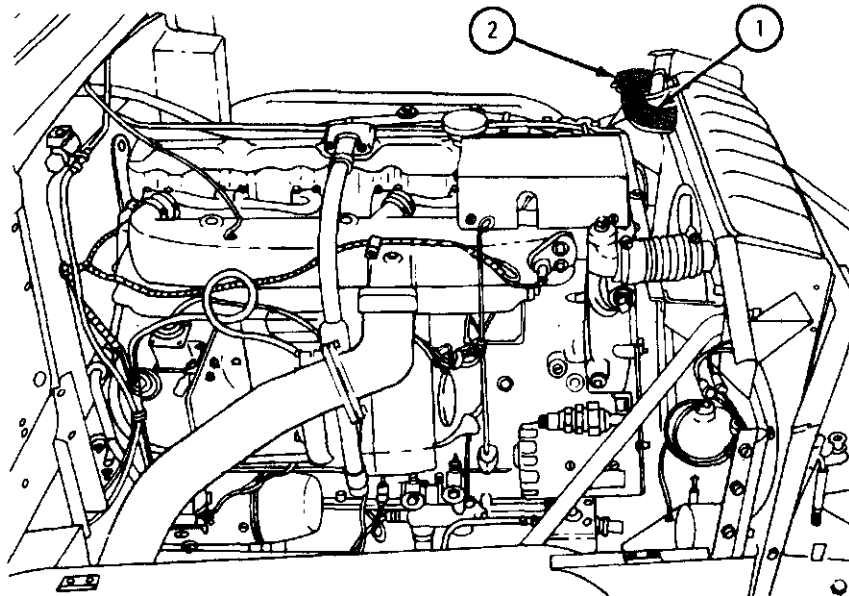

TA 083304

FRAME 2

NOTE

Put cardboard in front of radiator to raise engine temperature if needed, but do not let coolant boil.

1. Run engine at 650 to 700 rpm until engine temperature reaches 160°F to 180°F . Run engine for at least 15 minutes.
2. Stop engine. Refer to TM 9-2320-209-10.

WARNING

Do not take off filler cap (1) before pressure has been let out. Pressure will blow out scalding fluid and vapor. Personnel can be badly burned.

3. Put heavy cloth over radiator filler cap (1). Press down and turn filler cap slowly to left to the first stop. Let all pressure out of cooling system.
4. Press down and turn filler cap (1) all the way to left and lift it off.

GO TO FRAME 3

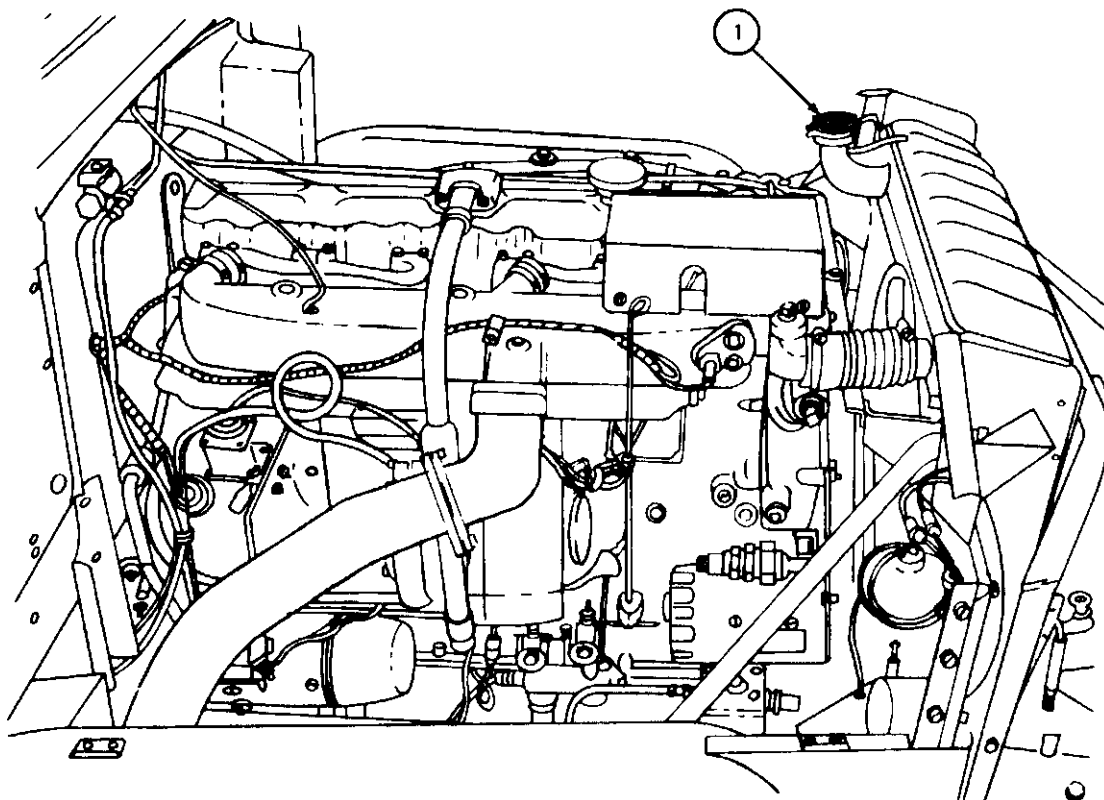

TA 083305

FRAME 3

1. Put containers under engine block drain cock (1) and radiator drain cock (2). Turn two drain cocks to left and let neutralizing solution drain into two containers.
2. When all neutralizing solution has drained out, turn two drain cocks (1 and 2) to right to close them.
3. Empty neutralizing solution in approved disposal area.

GO TO FRAME 4

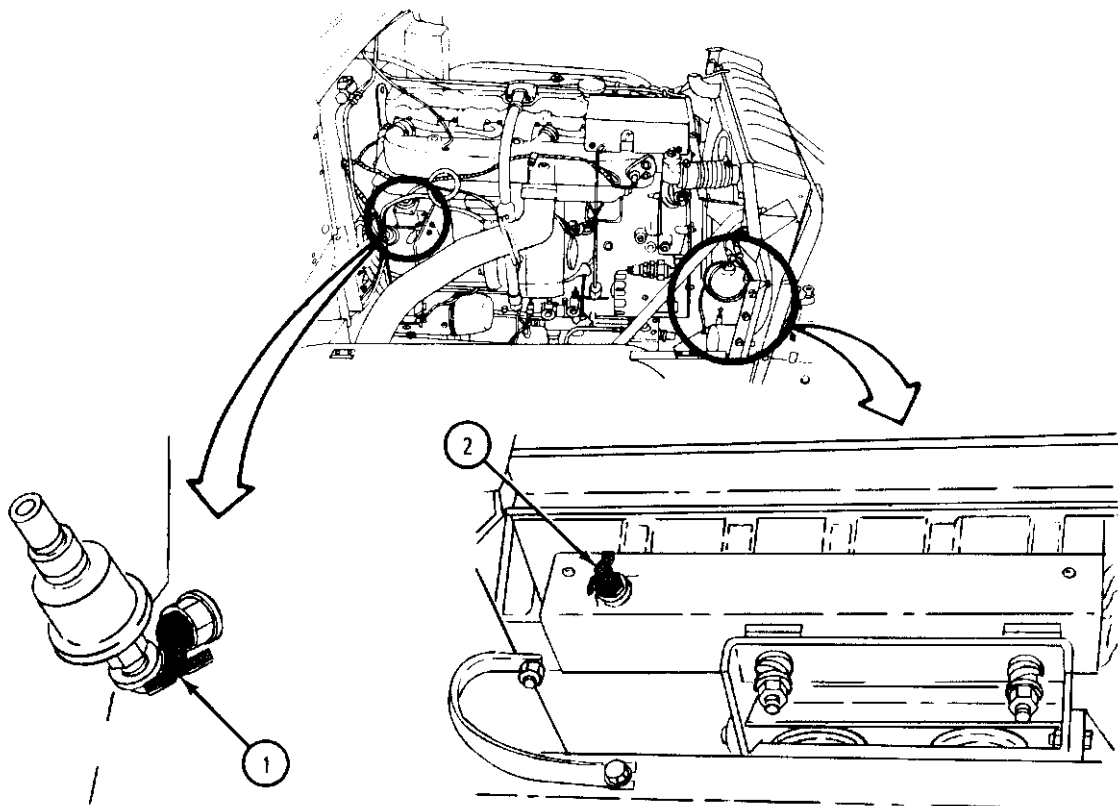

TA 083306

FRAME 4

1. Fill a 5-gallon container with water to within 1 inch of the top.
2. Add 1 bag of alkaline conditioner to water and mix thoroughly.
3. Pour contents of 5-gallon container into filler tube (1).
4. Fill cooling system with water.
5. Put on filler cap (2) and press down and turn it all the way to the right.

NOTE

Put cardboard in front of radiator to raise engine temperature if needed, but do not let solution boil.

6. Start engine and let it run for 60 minutes after engine temperature reaches 160°F to 180°F. Refer to TM 9-2320-209-10.

GO TO FRAME 5

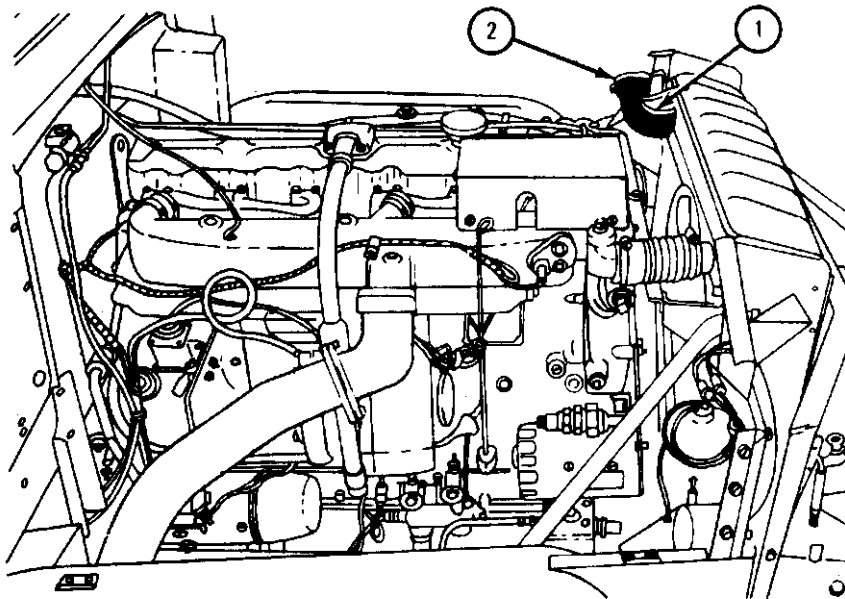

TA 083304

FRAME 5

1. Stop engine. Refer to TM 9-2320-209-10.

WARNING

Do not take off filler cap (1) before pressure has been let out. Pressure will blow out scalding fluid and vapor. Personnel can be badly burned.

2. Put heavy cloth over radiator filler cap (1). Press down and turn filler cap slowly to left to the first stop. Let all pressure out of cooling system.
3. Press down and turn filler cap (1) all the way to left and lift it off.
4. Do frame 3 again.

GO TO FRAME 6

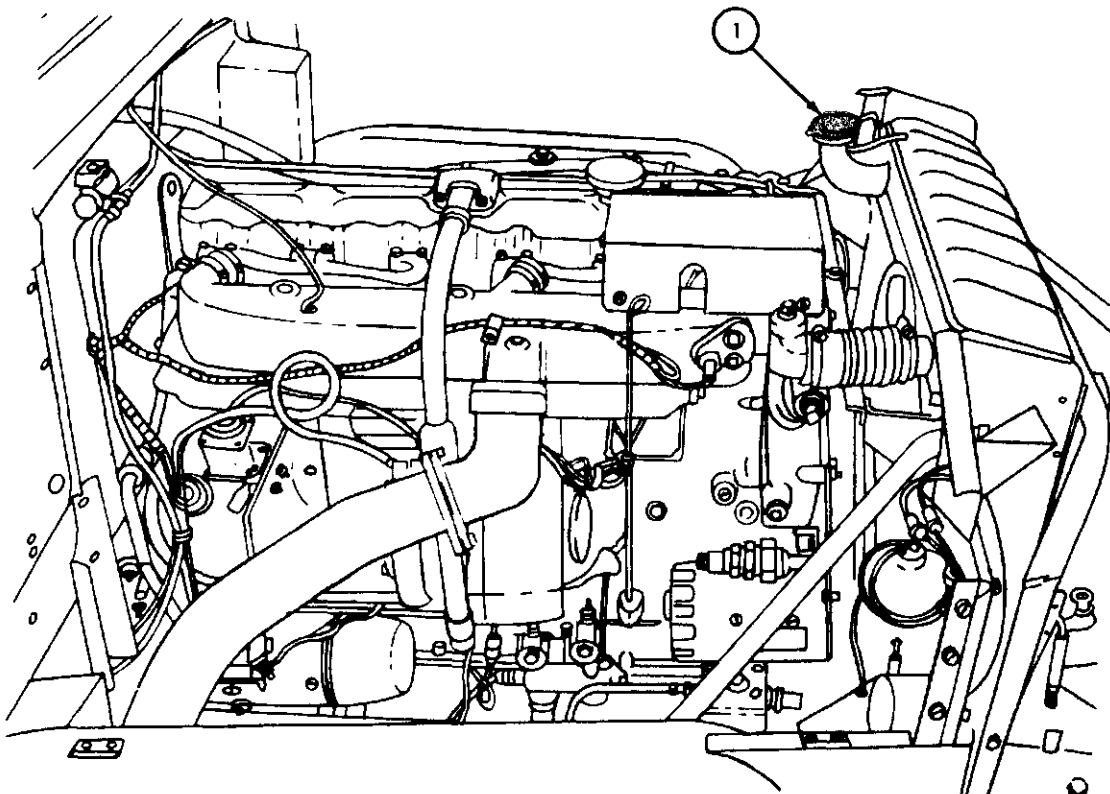

TA 083305

FRAME 6

1. Fill cooling system with water.
2. Start engine and let it run for 15 minutes. Refer to TM 9-2320-209-20.
3. Stop engine. Refer to TM 9-2320-209-10.

WARNING

Do not take off filler cap (1) before pressure has been let out. Pressure will blow out scalding fluid and vapor. Personnel can be badly burned.

4. Put heavy cloth over radiator filler cap (1). Press down and turn filler cap slowly to left to the first stop. Let all pressure out of cooling system.
5. Press down and turn filler cap (1) all the way to left and lift it off.
6. Do frame 3 again.

END OF TASK

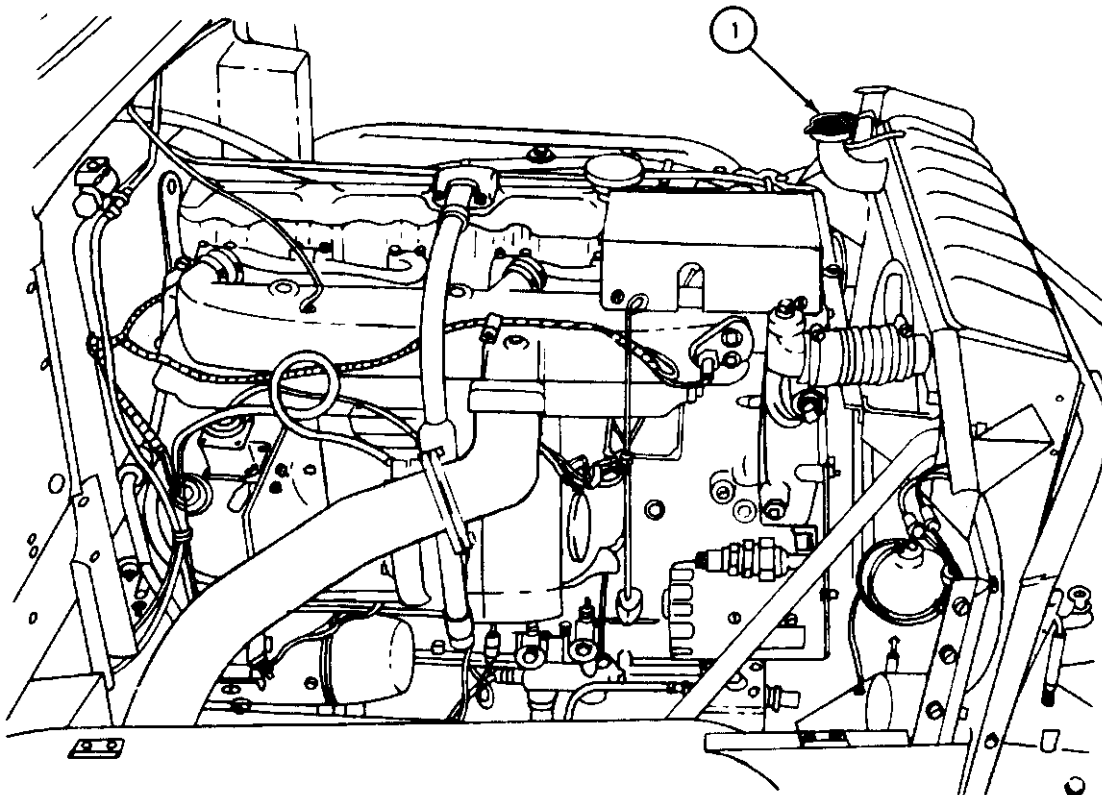

TA 083305

f. Filling.

FRAME 1

1. Fill engine cooling system with coolant to suit local temperature conditions. Refer to table 6-1.
2. Put on filler cap (1) and press down and turn it all the way to the right.
3. Start engine and let it run until engine temperature is 160°F to 180°F. Refer to TM 9-2320-209-10.

GO TO FRAME 2

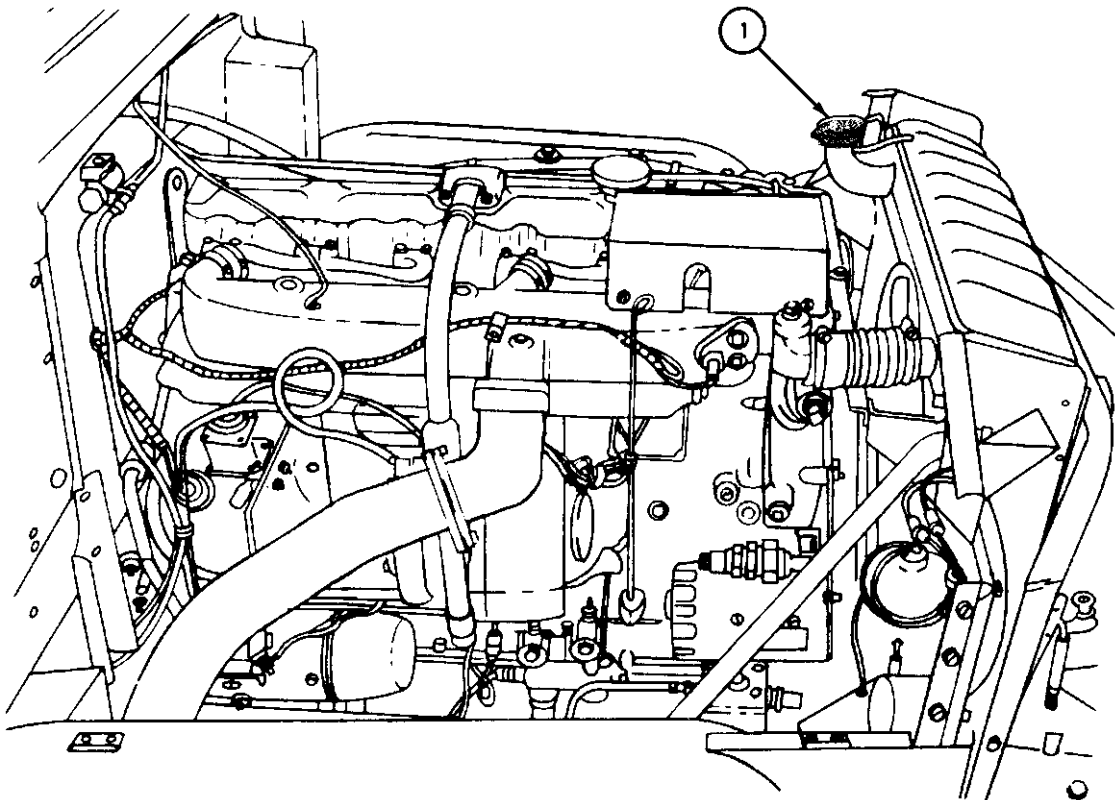

TA 083305

Table 6-1. Guide for Preparation of Antifreeze Solution.

Lowest expected ambient temperature (°F)	Ethylene-glycol (- 60°F) inhibited (O-A-548)		Arctic grade antifreeze (-90°F) MIL-A-11755
	Quarts per gallon of coolant capacity (Notes 1, 2)	Specific gravity (68°F)	
+20	3/4	1.022	Freezing point of -90°F. Issued ready for use and must not be mixed with any other liquid.
+10	1	1.036	
0	1 1/3	1.047	
-10	1 2/3	1.055	
-20	1 3/4	1.062	
-30	2	1.067	
-40	2 1/8	1.073	
-50	2 1/4		
-60	2 1/3		
Below -60	Use arctic grade antifreeze (-90°F)		

NOTES :

- Includes heaters.
- Proportions are in terms of ethylene-glycol per gallon and not quarts of ethylene-glycol added to each gallon of water. For example, at -30°F a gallon of coolant contains two quarts of ethylene-glycol and two quarts of water (2 quarts + 2 quarts = 4 quarts = 1 gallon).

FRAME 2

1. Stop engine. Refer to TM 9-2320-209-10.

WARNING

Do not take off filler cap (1) before pressure has been let out. Pressure will blow out scalding fluid and vapor. Personnel can be badly burned.

2. Put heavy cloth on filler cap (1). Press down and turn filler cap slowly to left to the first stop. Let all pressure out of cooling system.
3. Press down and turn filler cap (1) all the way to left and lift it off.
4. Check coolant level. Add coolant until coolant level is 1 inch from top of filler neck (2).
5. Put on filler cap (1) and press down and turn it all the way to right.
6. Check all engine cooling system parts for leaks.

NOTE

Follow-on Maintenance Action Required:

Close hood and right side panel. Refer to TM 9-2320-209-10.

END OF TASK

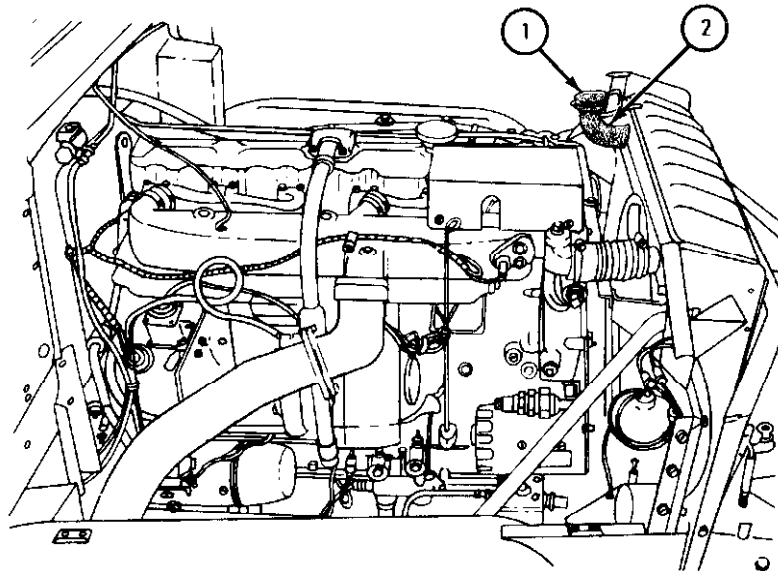

TA 084109

CHAPTER 7

ELECTRICAL SYSTEM GROUP MAINTENANCE

Section I. SCOPE

7-1. EQUIPMENT ITEMS COVERED. This chapter gives equipment maintenance procedures for the charging system, starting system, instrument panel components, lighting system, sending unit gages and warning buzzers, horn assembly, battery system, chassis harness, and miscellaneous items for which there are authorized corrective maintenance tasks at the organizational maintenance level.

7-2. EQUIPMENT ITEMS NOT COVERED. All equipment items for which corrective maintenance is authorized at the organizational maintenance level are covered in this chapter.

Section II. CHARGING SYSTEM

7-3. GENERATOR AND PULLEY REMOVAL AND REPLACEMENT.

<p>TOOLS :</p> <ul style="list-style-type: none"> 9/16-inch open wrench 5/8-inch socket wrench (2) 0.005-inch feeler gage Torque wrench, 150 pound-foot capacity Strap wrench 	<ul style="list-style-type: none"> Mechanical puller Jumper wire with pins (for polarization) Spanner wrench, 3/4 inch to 2 inches 3/4-inch socket wrench
--	---

SUPPLIES : Shim set
 Solvent, dry cleaning, type II (SD-2),
 Fed. Spec. P-D-680

PERSONNEL: One

EQUIPMENT CONDITION : Truck parked, engine off, handbrake set.

a. Preliminary Procedures.

- (1) Remove battery ground cable. Refer to para 7-58.
- (2) Open hood and both side panels. Refer to TM 9-2320-209-10.

b. Removal.

FRAME 1

1. Using spanner wrench, unscrew and take off electrical connector (1). Cover connector and mating receptacle (2) with protective caps.
2. Using 9/16-inch wrench, unscrew and take off bolt, lockwasher, and key washer (3).
3. Pull adjustment bracket (4) up and away from generator (5).
4. Push generator toward engine and take two V-belts (6) off pulley (7).

GO TO FRAME 2

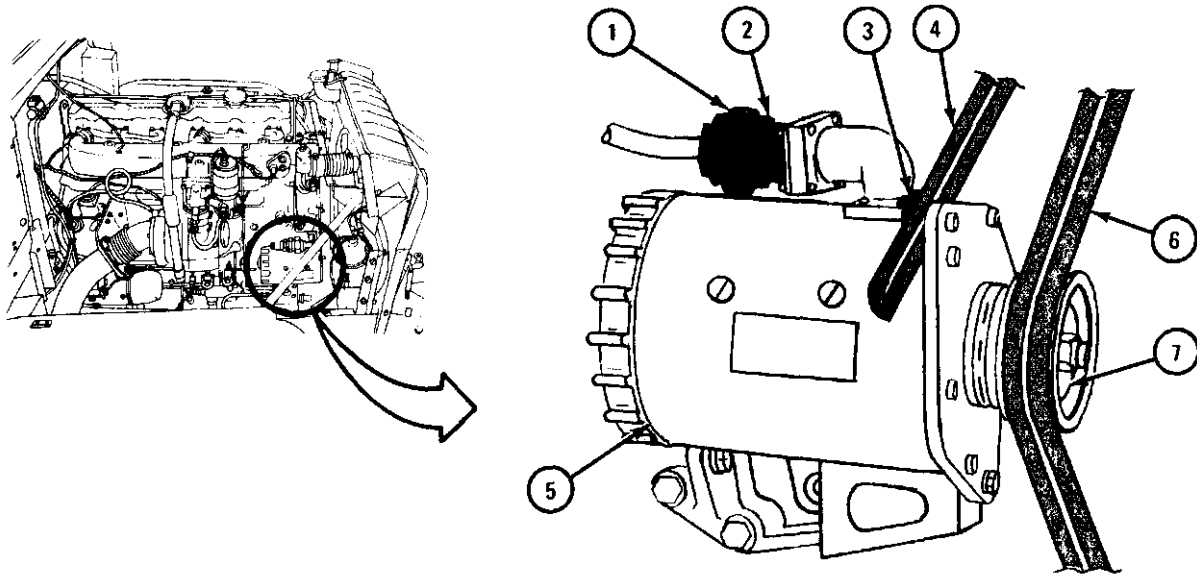

TA 047101

FRAME 2

1. Using 5/8-inch socket wrenches, unscrew two nuts and washers (1) from bolts (2).

NOTE

Be careful when pulling out generator rear bolt (2).
Shims (3) may fall out.

2. Hold generator (4) up with one hand and pull bolts (2) out of mounting bracket (5). Leave two flat washers (6) on bolts.
3. Take shims (3) out from between generator (4) and mounting bracket (5). Set shims aside.
4. Lift out generator (4).

GO TO FRAME 3

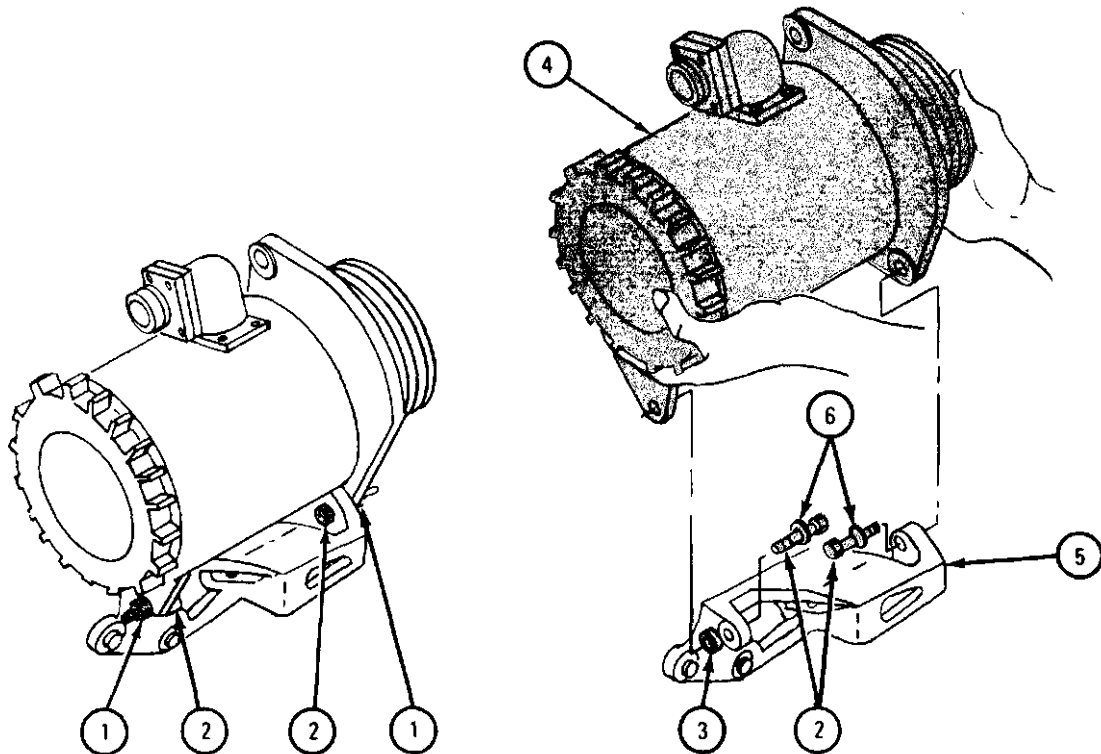

TA 047102

FRAME 3

1. Put strap wrench (1) around pulley (2) as shown. Pull end of strap so that it is tight on pulley.
2. Using 3/4-inch socket wrench , unscrew and take off locknut (3) and flat washer (4).

GO TO FRAME 4

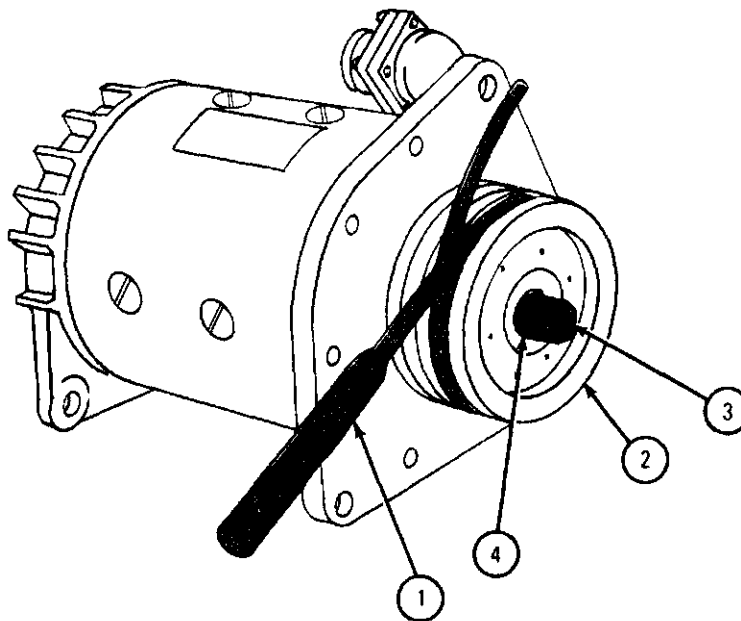

TA 047103

FRAME 4

1. Using mechanical puller (1), set adjustable arms (2) of puller over rear edge of generator pulley (3) as shown.
2. Screw puller bolt (4) in until it presses against generator shaft (5) as shown.
3. Using 3/4-inch socket wrench, slowly tighten puller bolt (4) until generator pulley (3) is loose on shaft (5). Pulley will move in direction shown.
4. Take puller (1) off generator pulley (3) and slide pulley off end of shaft (5).
5. Tape key (6) to shaft (5) so it will not be lost.

END OF TASK

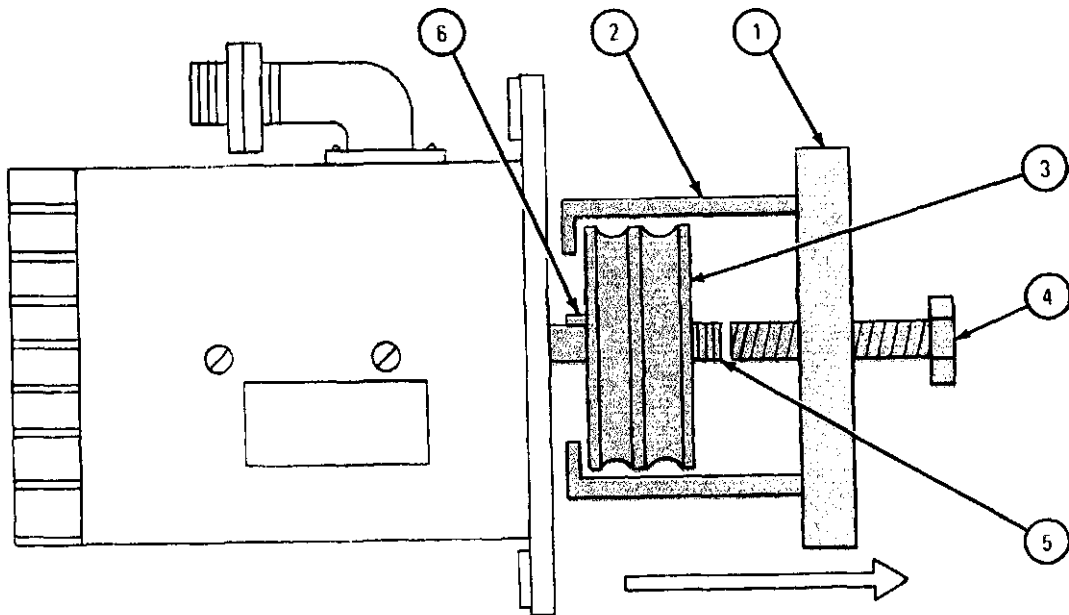

TA 087781

c. Replacement.

FRAME 1

WARNING

Dry cleaning solvent is flammable. Do not use near an open flame. Keep a fire extinguisher nearby when solvent is used. Use only in well-ventilated places. Failure to do this may result in injury to personnel and damage to equipment.

NOTE

If key (1) is taped on shaft (2), take off tape. Clean key and shaft with solvent, then put key in slot.

1. Put key (1) in slot of shaft (2).
2. Line up keyway (3) in pulley (4) with key (1) in shaft (2). Put pulley on shaft and press firmly. Key (1) should not show at back of pulley.
3. Put flat washer (5) on shaft (2) and screw on locknut (6) finger tight.

GO TO FRAME 2

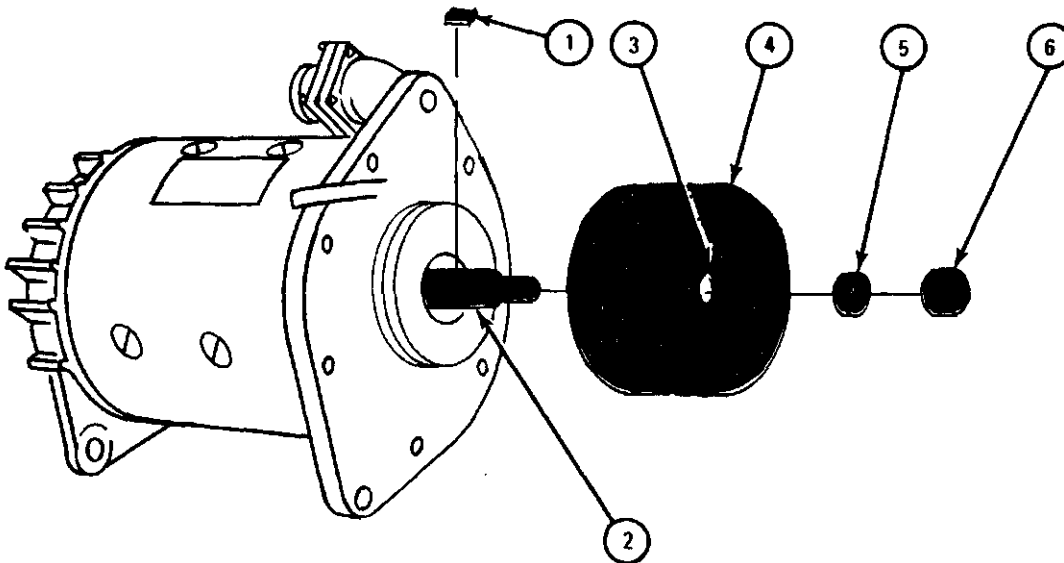

TA 047105

FRAME 2

1. Put strap wrench (1) around pulley (2) as shown. Pull end of strap so that it is tight around pulley.
2. Using torque wrench, tighten locknut (3) to 40 to 50 pound-feet while holding pulley (2) with strap wrench (1).

GO TO FRAME 3

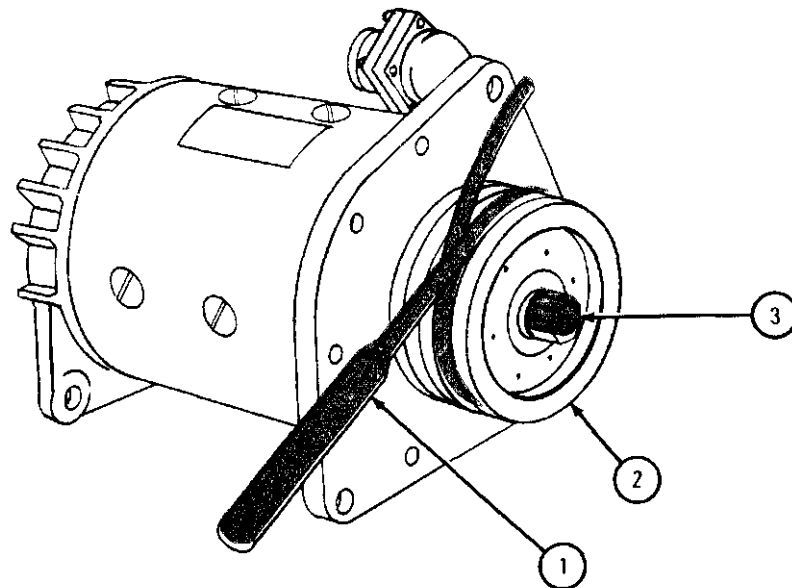

TA 047106

FRAME 3

1. Hold generator (1) by hand and set it on mounting bracket (2).

NOTE

Generator flanges (3) go on outside of mounting bracket flanges (4).

2. Aline holes in generator flanges (3) with holes in mounting bracket flanges (4)
3. Put two bolts (5) with flat washers (6) through mounting holes as shown.

GO TO FRAME 4

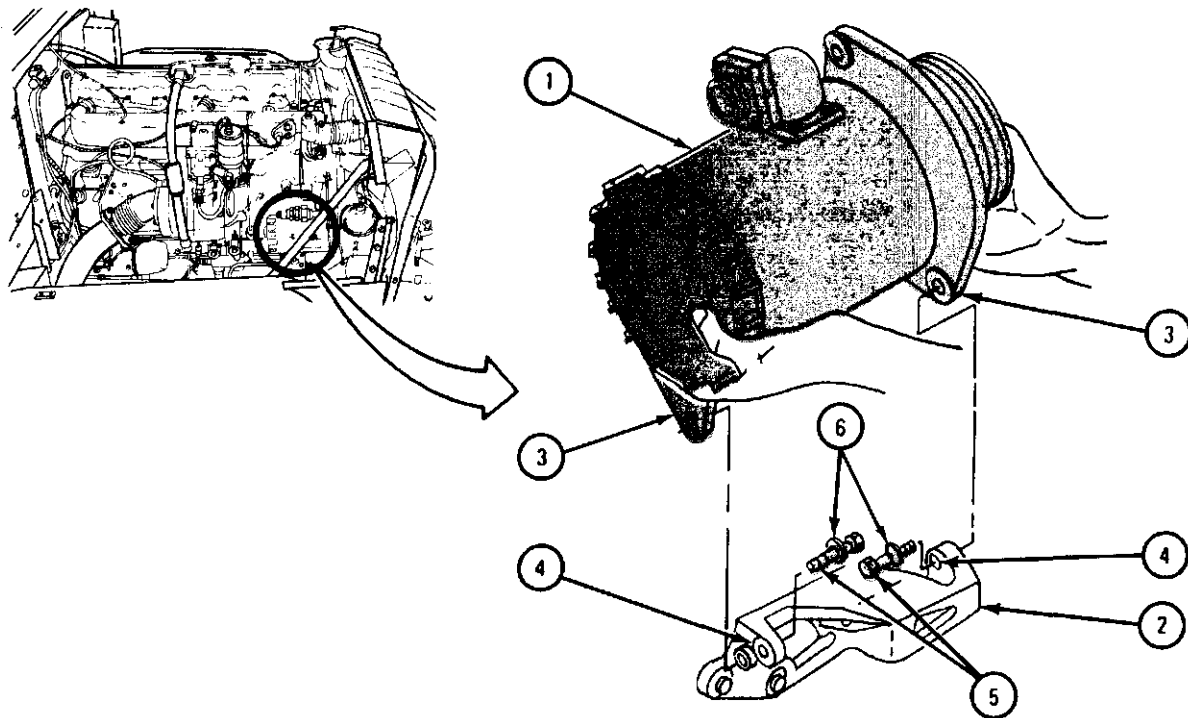

TA 047107

FRAME 4

1. Push generator (1) toward firewall as shown. Front flange on generator must be hard against front flange on mounting bracket (2).
2. Put 0.005-inch feeler gage between rear flange on generator (1) and shims between rear flange on mounting bracket (2). Feeler gage should fit between flanges very easily.

NOTE

Hold rear of generator (1) up when sliding bolt (3) out of flange to put in shims (4).

3. Pull bolt (3) out of rear flange on generator (1). Slip shims (4) between generator flange and rear flange on mounting bracket (2). Put bolt back in.
4. Do steps 1, 2 and 3 again as necessary, adding shims (4) until feeler gage makes snug fit between shims (4) and rear flange on generator (1).
5. Screw two nuts (5) on bolts (3 and 6) finger tight.
6. Using torque wrench, tighten nuts (5) to 65 to 70 pound-feet.

GO TO FRAME 5

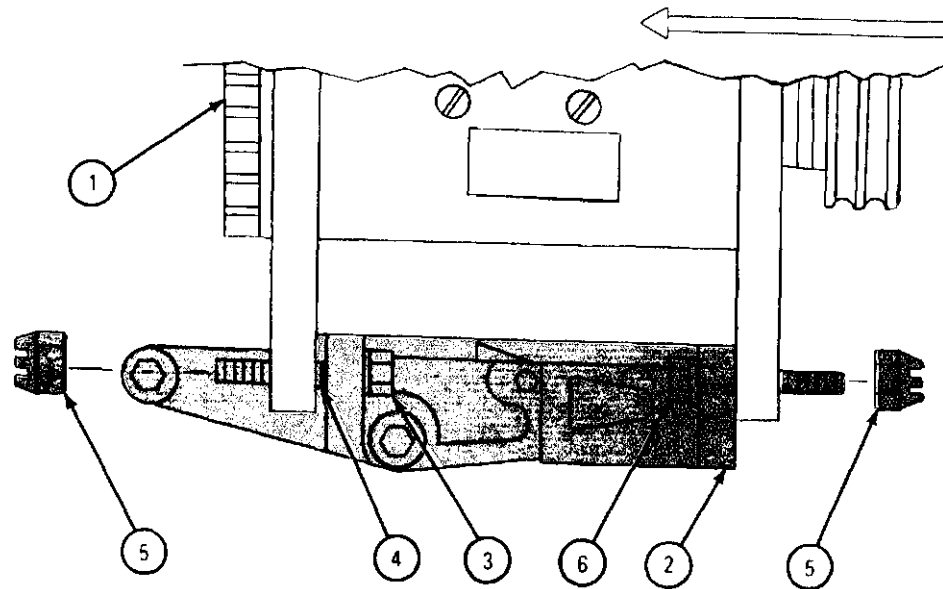

TA 047108

FRAME 5

1. Push generator (1) toward engine and slip two V-belts (2) around pulley (3).

NOTE

Do not hook up electrical connector to generator at this time. Polarization procedure must be done first.

2. Put lockwasher (4) and key washer (5) on bolt (6).
3. Put bolt (6) through adjustment bracket (7), and screw bolt into generator flange (8) finger tight.

NOTE

Bolt (6) is not tightened until fan belt adjustment has been done.

NOTE

Follow-on Maintenance Action Required:

1. Adjust fan belt. Refer to para 6-9.
2. Do polarization procedure. Refer to para 7-3d.
3. Start engine and check that battery-generator indicator is in the green area. Stop engine. Refer to TM 9-2320-209-10.
4. Close hood and right side panel. Refer to TM 9-2320-209-10.

END OF TASK

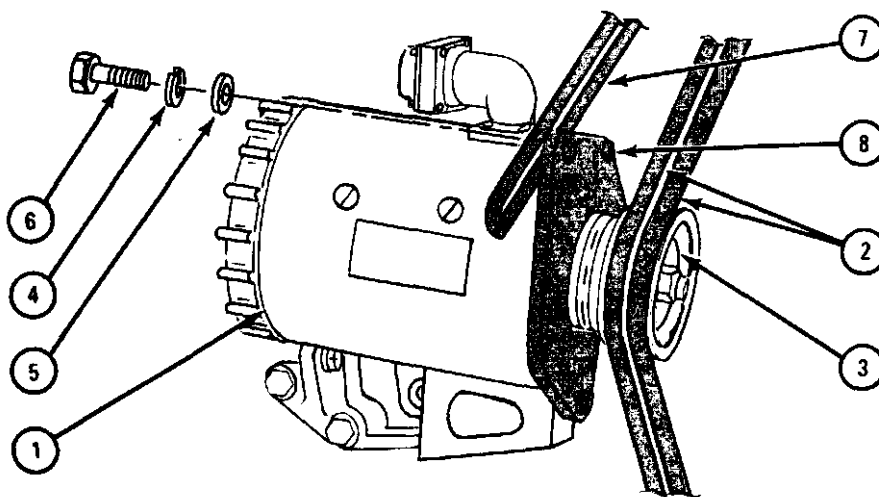

TA 047109

d. Polarization.

FRAME 1

1. Using spanner wrench, unscrew and take off chassis wiring harness connector (1) from voltage regulator (2).

CAUTION

Make sure connector (1) pins do not touch on the engine.
Pin A on connector goes directly to positive battery terminal.

2. Reconnect battery ground cable. Refer to para 7-58.

GO TO FRAME 2

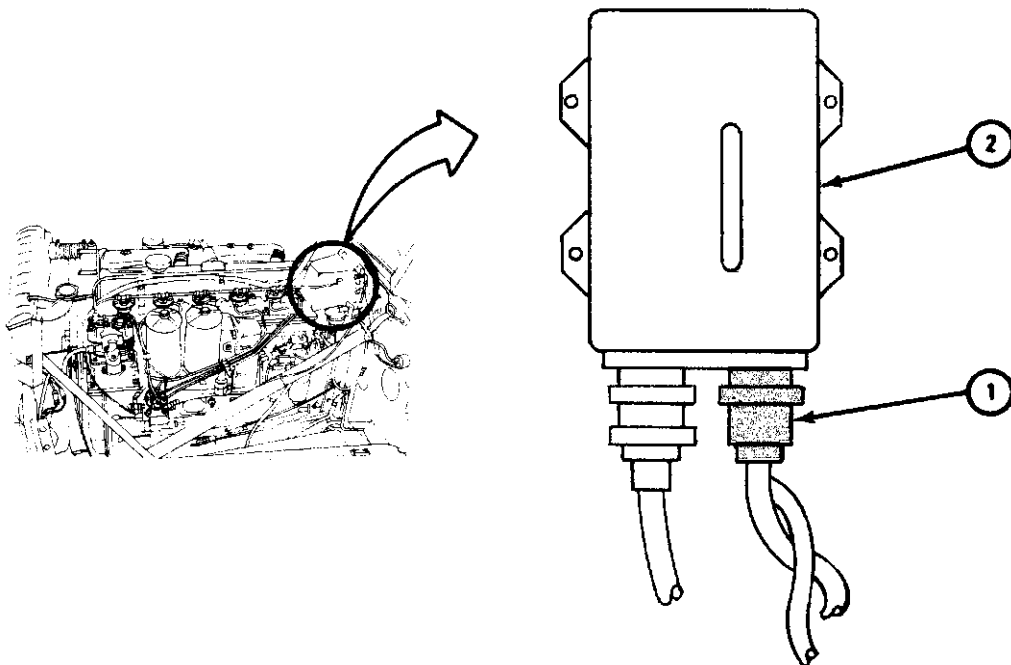

TA 047110

FRAME 2

WARNING

Be very careful when using jumper wires (2). Shorting wire to ground can burn connector pins or wiring and cause injury to personnel and damage to equipment.

1. Put male pin (1) of jumper wire (2) into pin B of generator receptacle (3).
2. Put female connector (4) of jumper wire (5) onto pin A of chassis wiring harness connector (6).
3. Holding jumper wire (2) in one hand and jumper wire (5) in the other, briefly strike wires together. Do not let them stay together.

NOTE

Chassis wiring harness connector (6) was taken off voltage regulator at start of task.

4. Disconnect battery ground cable. Refer to para 7-58.
5. Take away jumper wires (2 and 5).

GO TO FRAME 3

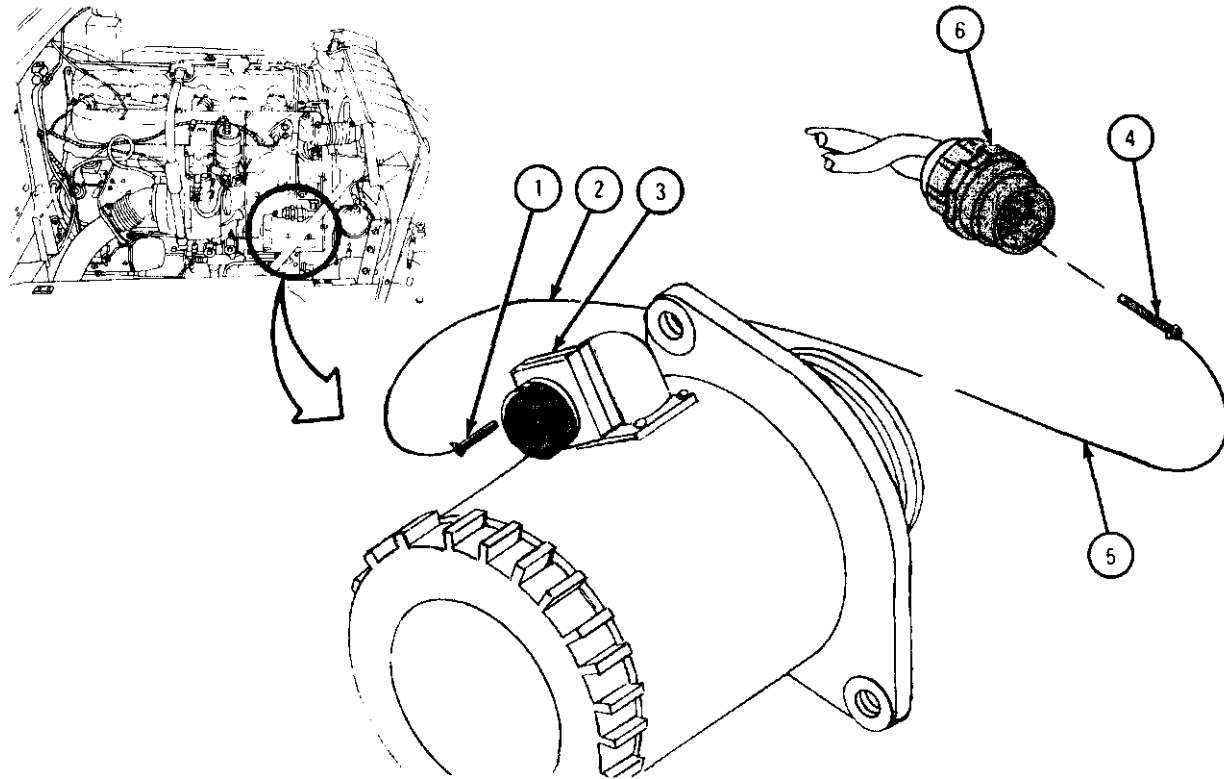

TA 047111

FRAME 3

1. Using spanner wrench, join chassis wiring harness connector (1) to voltage regulator receptacle (2) and tighten connector.
2. Using spanner wrench, join generator connector (3) to generator receptacle (4) and tighten connector.
3. Reconnect battery ground cable. Refer to para 7-58.

END OF TASK

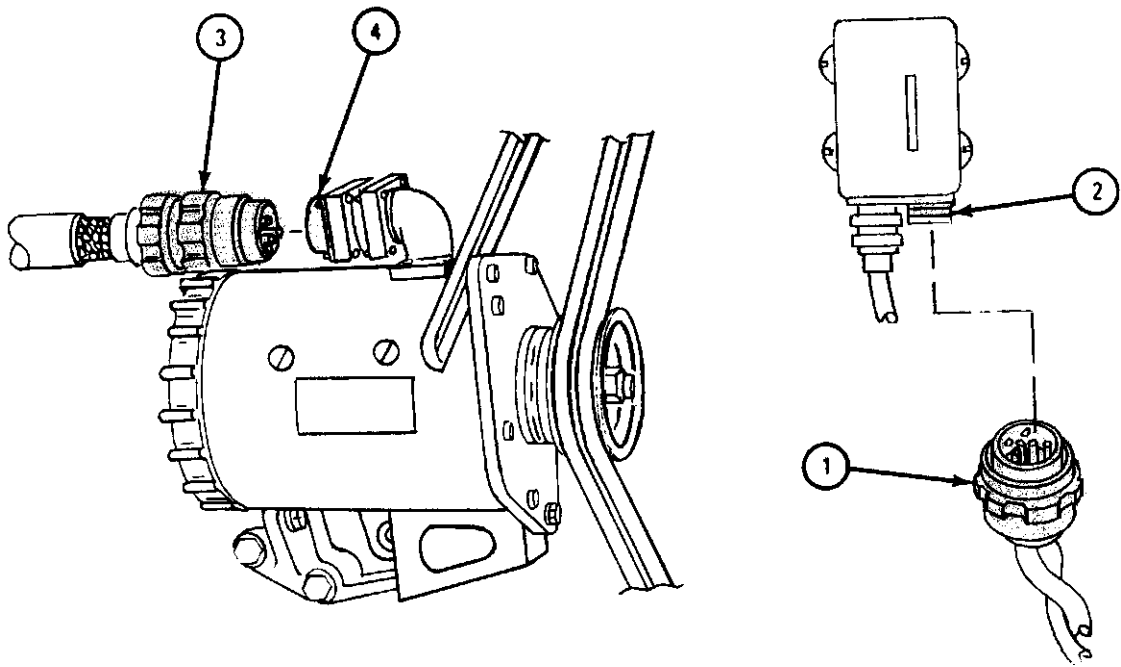

TA 047112

7-4. ALTERNATOR AND PULLEY REMOVAL AND REPLACEMENT.

TOOLS: Flat-tip screwdriver Mechanical puller
 0.005-inch feeler gage Strap wrench
 7/16-inch socket wrench 3/4-inch wrench
 Torque wrench, 150 1/2-inch wrench
 pound-foot capacity 5/8-inch wrench
 Torque wrench, 200 15/16-inch wrench
 pound-inches capacity 9/16-inch wrench

SUPPLIES: Solvent, dry cleaning, type II (SD-2), Fed. Spec P-D-680
 Silicone dielectric compound, MIL-S-8660B

PERSONNEL: One

EQUIPMENT CONDITION: Truck parked, engine off, handbrake set.

a. Preliminary Procedures.

- (1) Disconnect battery ground cable. Refer to para 7-58.
- (2) Open hood and right side panel. Refer to TM 9-2320-209-10.

b. Removal.

FRAME 1

NOTE

Cover mounting screws (1) may be at the rear of cover on some alternators.

1. Using screwdriver, unscrew and take out two screws and lockwashers (1).
2. Lift off terminal cover (2).
3. Using screwdriver, unscrew and take out two screws and lockwashers (3).
4. Take off hold down clamp (4).

GO TO FRAME 2

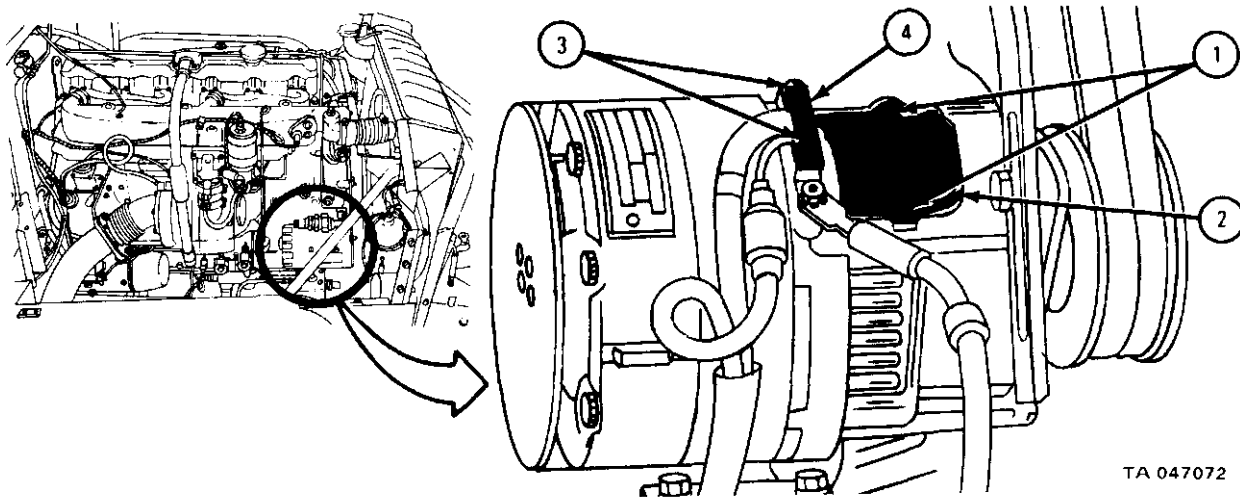

TA 047072

FRAME 2

1. Using 7/16-inch wrench, unscrew and take off nut and lockwasher (1). Lift off cable (2).
2. Using 1/2-inch wrench, unscrew and take off bolt and lockwasher (3). Lift off ground cable (4).
3. Take plug (5) out of connector (6).

GO TO FRAME 3

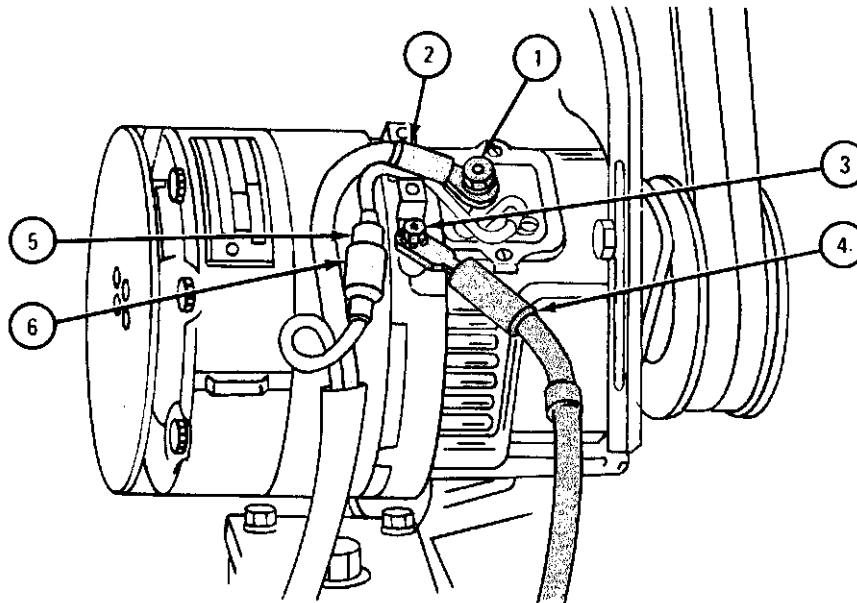

TA 047073

FRAME 3

1. Using 9/16-inch wrench, unscrew and take bolt, lockwasher and key washer (1) out of adjustment bracket (2).
 2. Swing adjustment bracket,(2) up and away from alternator (3).
 3. Push alternator (3) toward engine and take two V-belts (4) off pulley (5).
- GO TO FRAME 4

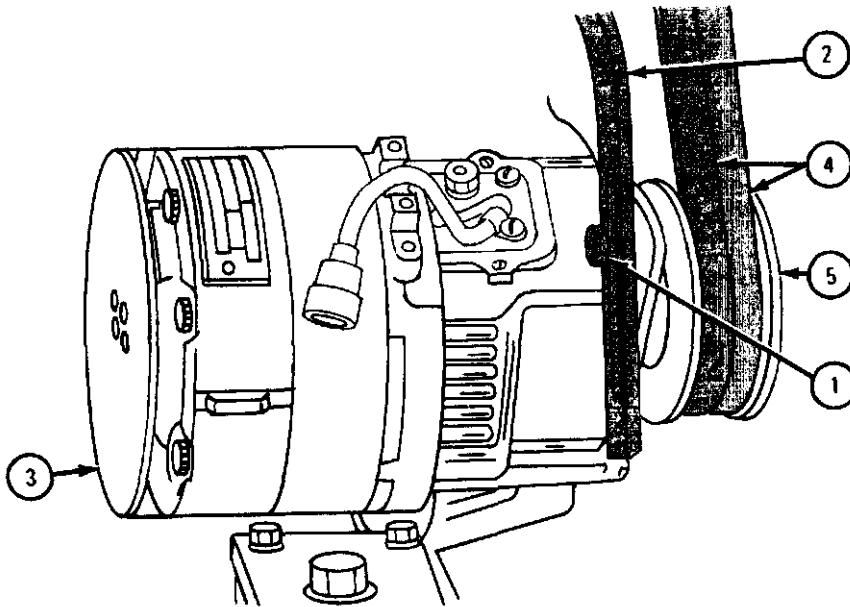

TA 047074

FRAME 4

1. Using pliers, take two cotter pins (1) out of two bolts (2) and throw cotter pins away.
2. Using 5/8-inch wrenches, unscrew and take off two nuts and washers (3) from bolts (2).

NOTE

Be careful when pulling out alternator rear bolt. Shim (4) may fall out.

3. Hold alternator (5) up and pull bolts (2) out of mounting bracket (6). Leave two flat washers (7) on bolts.
4. Take shims (4) out from between alternator (5) and mounting bracket (6). Set shims aside.

WARNING

Be careful when lifting alternator. It is heavy and could injure personnel or damage equipment if dropped.

5. Lift out alternator (5).

GO TO FRAME 5

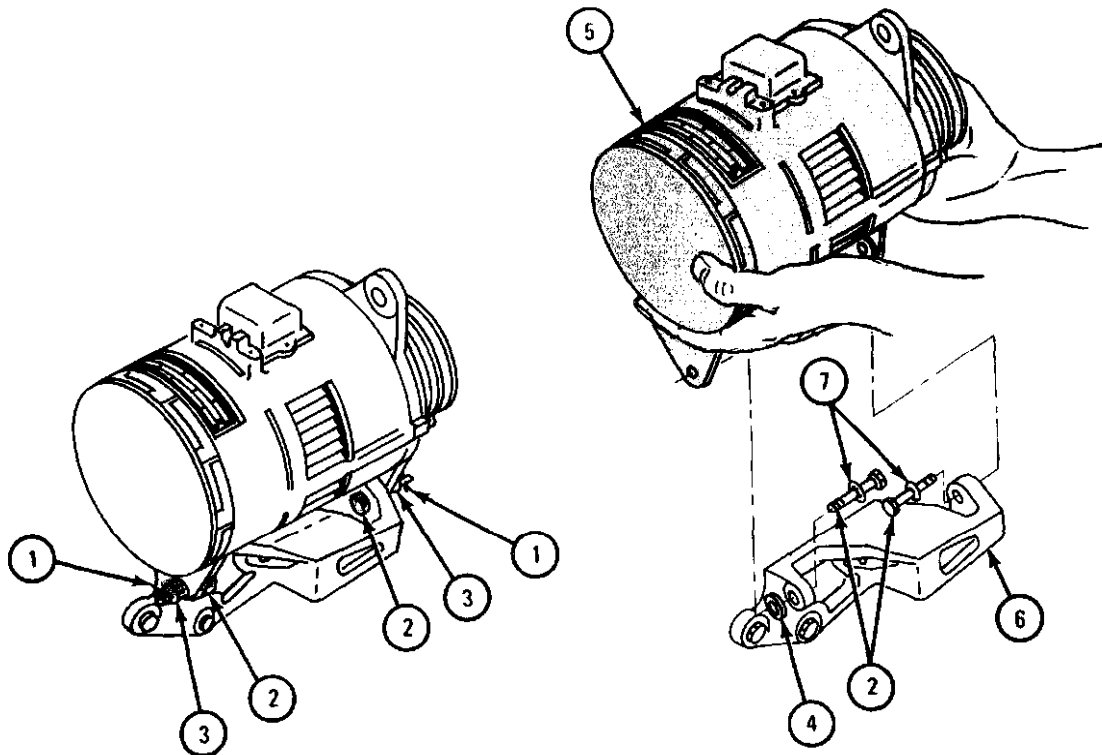

TA 047075

FRAME 5

1. Put strap wrench (1) around pulley (2) as shown. Pull end of strap so that it is tight on pulley.
2. Using 15/16-inch socket wrench, unscrew locknut (3) while holding pulley from turning with strap wrench (1).
3. Take off locknut (3) and flat washer (4).

GO TO FRAME 6

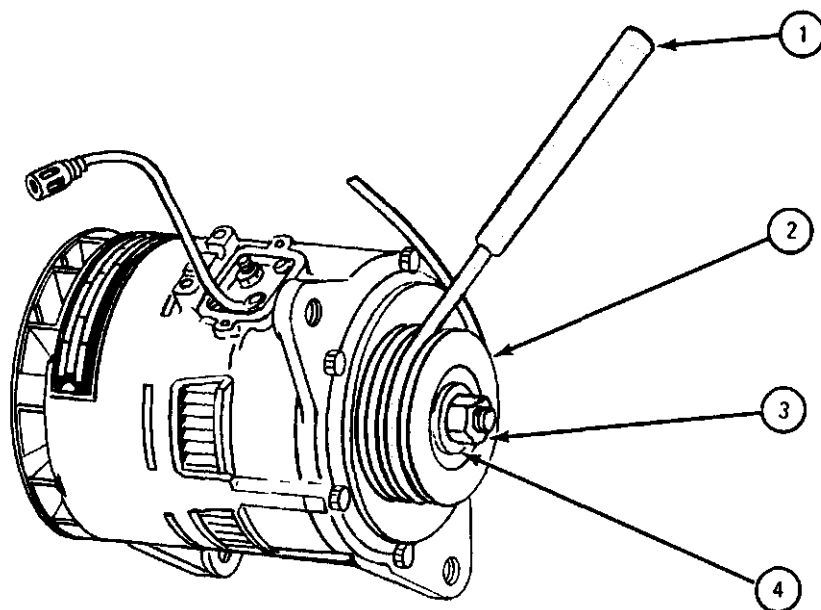

TA 047076

FRAME 6

1. Using mechanical puller (1), set adjustable puller arms (2) over rear edge of alternator pulley (3) as shown.
2. Screw puller bolt (4) in until it presses against alternator shaft (5) as shown.
3. Using 3/4-inch wrench, slowly tighten puller bolt (4) until alternator pulley (3) is loose on shaft (5). Pulley will move in direction shown.
4. Take puller (1) off alternator pulley (3) and slide pulley off end of shaft (5).
5. Tape key (6) to shaft (5) so it will not be lost.

END OF TASK

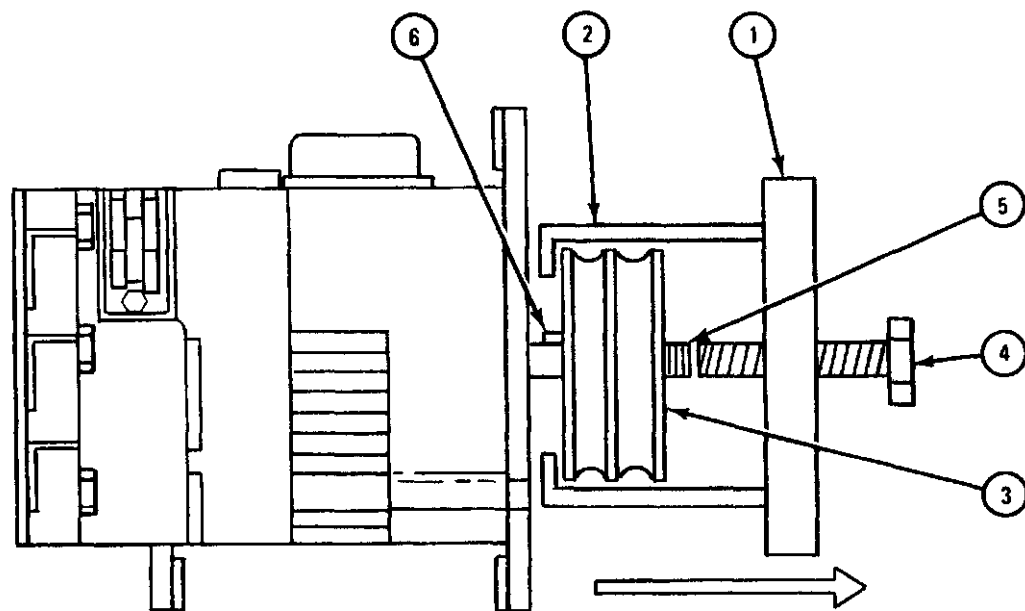

TA 047077

c. Replacement.

FRAME 1

WARNING

Dry cleaning solvent is flammable. Do not use near an open flame. Keep a fire extinguisher nearby when solvent is used. Use only in well-ventilated places. Failure to do this may result in injury to personnel and damage to equipment.

NOTE

If key (1) is taped on shaft, take off tape. Clean key and shaft with solvent, then put key in slot.

1. Put key (1) in slot (2).
2. Line up keyway (3) in pulley (4) with key (1) in shaft (5). Put pulley on shaft and press it on firmly.
3. Put flat washer (6) on shaft and screw on locknut (7) finger tight.

GO TO FRAME 2

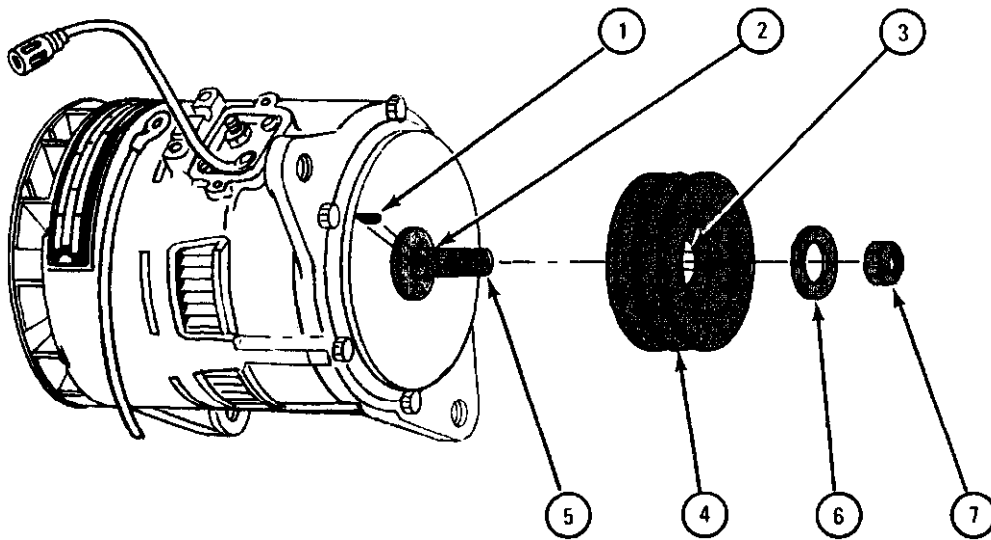

TA 047078

FRAME 2

1. Put strap wrench (1) around pulley (2) as shown. Pull end of strap so that it is tight around pulley.
2. Using torque wrench, tighten locknut (3) to 40 to 50 pound-feet while holding pulley (2) with strap wrench (1).

GO TO FRAME 3

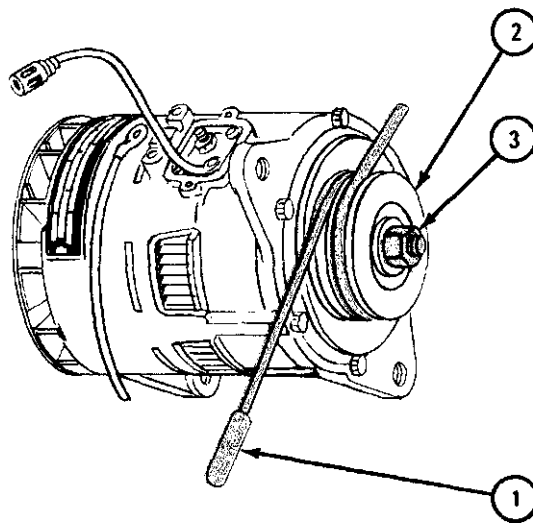

TA 047079

FRAME 3

1. Hold alternator (1) by hand and set it on mounting bracket (2) in engine compartment as shown.

NOTE

Alternator flanges (3) go on the outside of mounting bracket flanges (4).

2. Aline holes in alternator flanges (3) with holes in mounting bracket flanges (4).
3. Put two bolts (5), each with flat washer (6), through mounting holes as shown.

GO TO FRAME 4

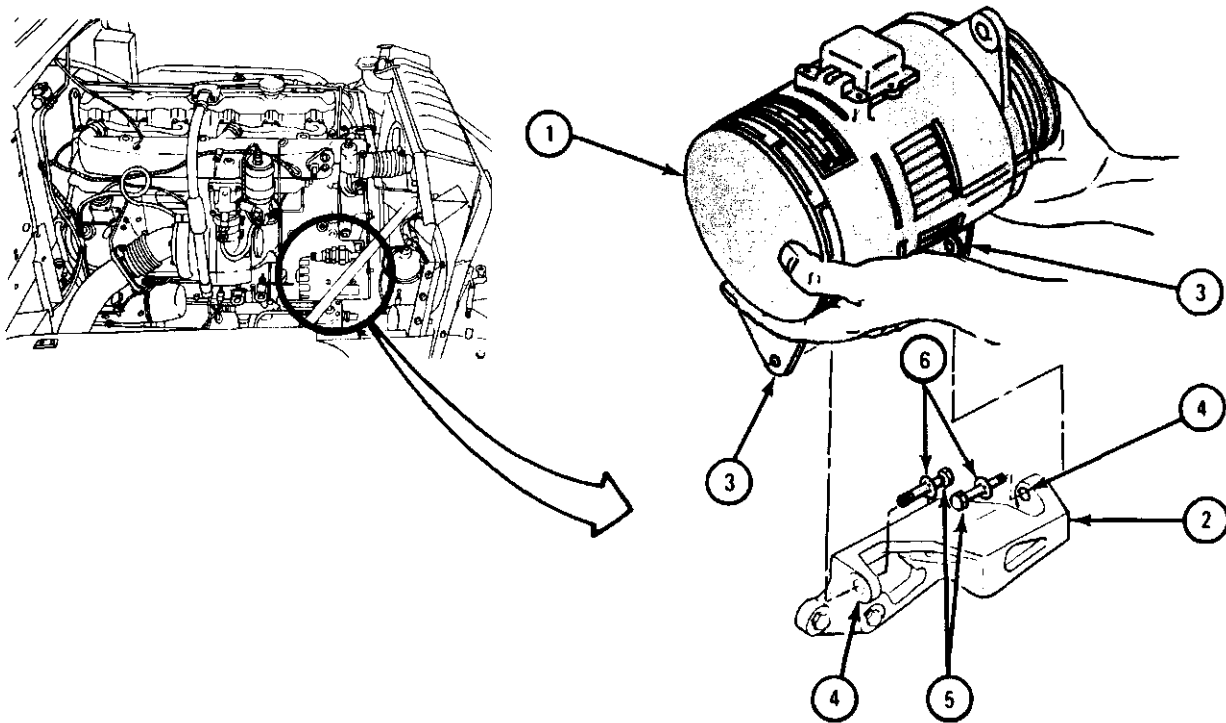

TA 047080

FRAME 4

1. Push alternator (1) toward firewall as shown. Front flange (2) on alternator must be hard against mounting bracket front flange (3).
2. Put 0.005-inch feeler gage between rear flange (4) on alternator (1) and mounting bracket rear flange (5). Feeler gage should fit between flanges very easily.

NOTE

Hold rear of alternator (1) up when sliding bolt (6) out of rear mounting flange (4) to put in shims (7).

3. Pull bolt (6) out of rear flange (4) on alternator (1). Slip shim (7) between alternator flange (4) and mounting bracket rear flange (5). Put bolt back in.
4. Do steps 1, 2, and 3 again as necessary, adding shims (7) until feeler gage makes snug fit between shims and alternator flange (4).
5. Screw two nuts (8) on bolts (6 and 9). Using torque wrench, tighten nuts to 65 to 70 pound-feet.
6. Using pliers, put two cotter pins (10) through nuts (8) and bolts (6 and 9).

GO TO FRAME 5

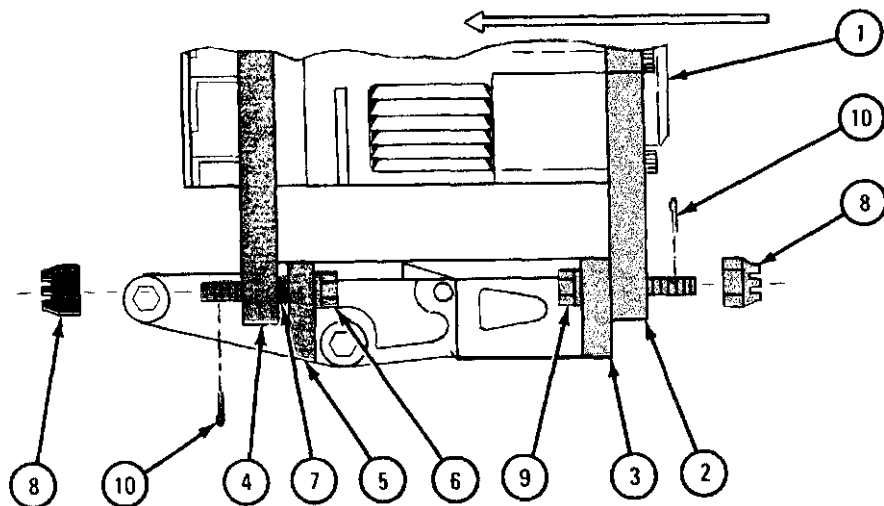

TA 047081

FRAME 5

1. Push alternator (1) toward engine and slip two V-belts (2) over pulley (3).
2. Swing adjustment bracket (4) down to alternator (1). Aline hole in flange (5) with slot in adjustment bracket.
3. Put lockwasher (6) and key washer (7) on bolt (8) as shown.
4. Put bolt (8) with washers (6 and 7) through slot in adjustment bracket (4) and screw into flange (5) finger tight.

NOTE

Bolt (8) will be tightened with wrench during fan belt tension adjustment procedure. This procedure is part of follow-on maintenance.

GO TO FRAME 6

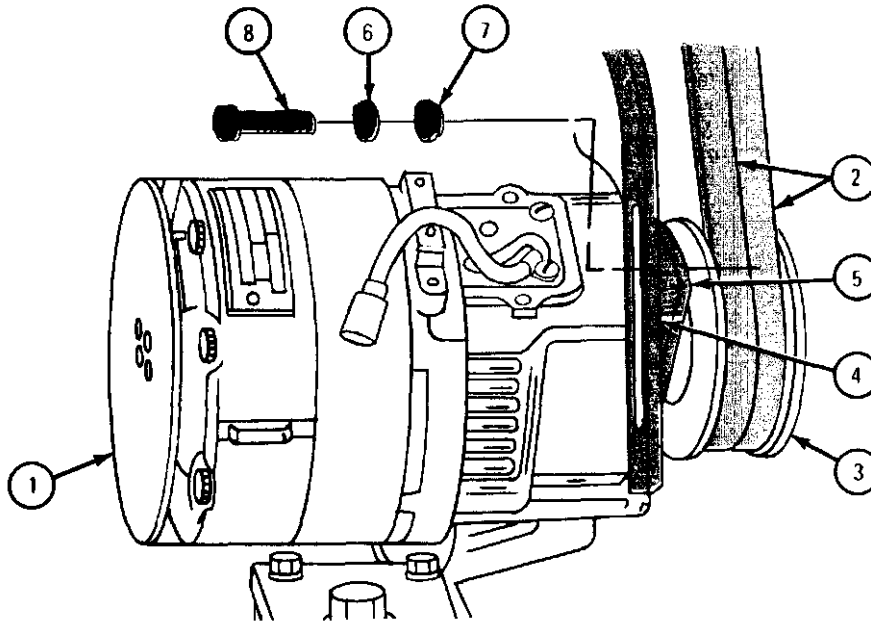

TA 047 082

FRAME 6

CAUTION

Be careful when putting positive cable terminal lug (1) on terminal (2). This cable goes to the battery. The lug is larger and more rounded on one side. This side must go up. Putting lug on the wrong way could short out the alternator and damage it.

1. Put positive cable terminal lug (1) on terminal (2) as shown. Put lockwasher (3) on terminal and screw on nut (4). Using torque wrench, tighten nut to 45 to 55 pound-inches.
2. Put ground cable terminal lug (5) over hole in terminal block (6) as shown. Put lockwasher (7) on bolt (8) and put bolt through terminal lug.
3. Screw bolt (8) into terminal block (6), and using torque wrench, tighten bolt to 82 to 102 pound-inches.

GO TO FRAME 7

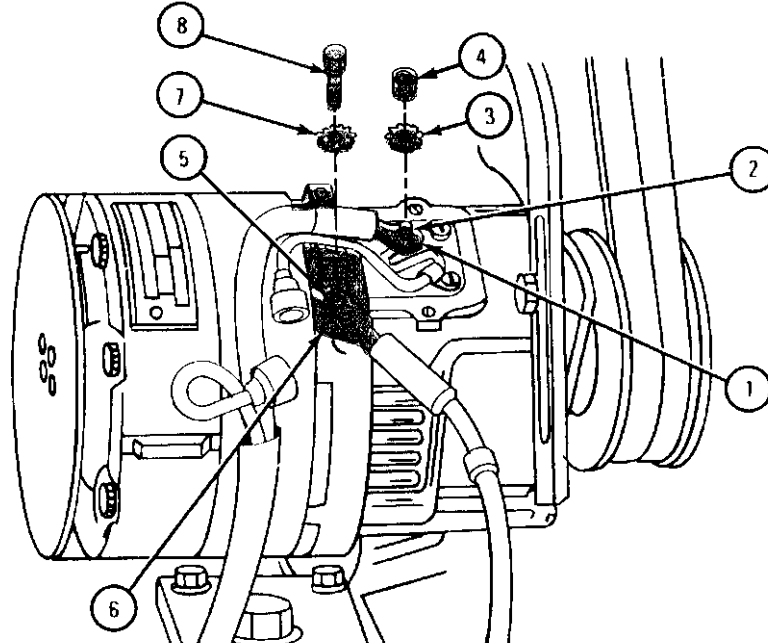

TA 047083

FRAME 7

1. Put hold down clamp (1) on block (2) and align holes.
2. Put in two screws and lockwashers (3). Using flat-tip screwdriver, tighten screws.
3. Seal terminal cover (4) and base (5) with silicone compound.
4. Put terminal cover (4) on base (5).
5. Put on two screws and lockwashers (6). Using screwdriver, tighten screws.
6. Join plug (7) to connector (8).

NOTE

Follow-on Maintenance Action Required:

1. Reconnect battery ground cable. Refer to para 7-58.
2. Adjust fan belt tension. Refer to para 6-9.
3. Start engine and check that battery-generator indicator is in green area. Stop engine. Refer to TM 9-2320-209-10.
4. Close hood and side panels. Refer to TM 9-2320-209-10.

END OF TASK

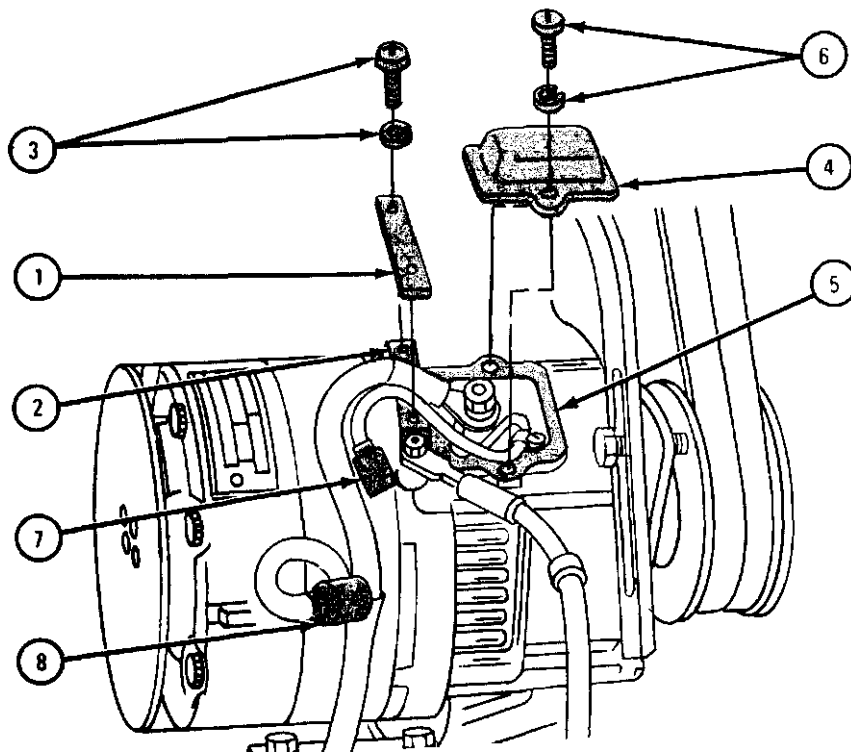

TA 047084

7-5. GENERATOR REGULATOR REMOVAL AND REPLACEMENT.

TOOLS: 1/2-inch open end wrench
Adjustable spanner wrench, 3/4-inch to 2-inch

SUPPLIES: None

PERSONNEL: One

EQUIPMENT CONDITION: Truck parked, engine off, handbrake set.

a. Preliminary Procedures.

- (1) Open hood and left side panel. Refer to TM 9-2320-209-10.
- (2) Disconnect battery ground cable. Refer to para 7-58.

b. Removal.

FRAME 1

1. Using adjustable spanner wrench, unscrew and take off generator cable connector (1) and chassis wiring connector (2) from generator regulator (3).

NOTE

Put protective caps over ends of the two cable connectors (1 and 2) and two receptacles on the regulator.

2. Using 1/2-inch wrench, unscrew and take off four nuts and lockwashers (4).
3. Take generator regulator (3) off shock mount assembly (5).

END OF TASK

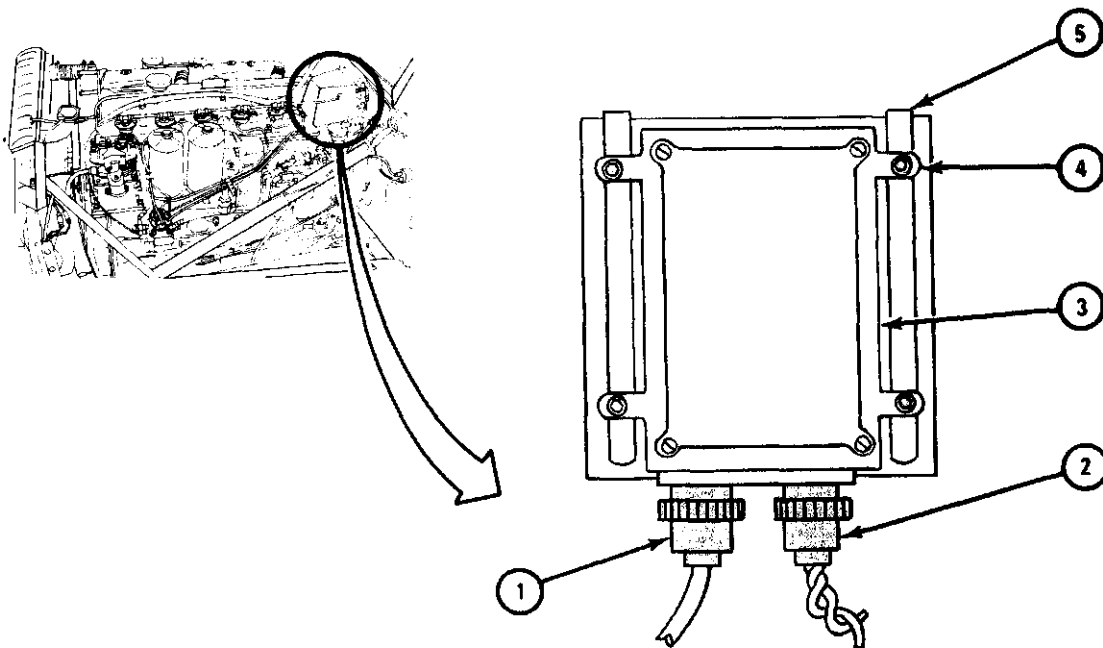

TA 047113

c. Replacement.

FRAME 1

1. Put generator regulator (1) on shock mount assembly (2) as shown.
2. Put on four lockwashers (3). Using 1/2-inch wrench, screw on and tighten four nuts (4).
3. Aline slot in generator cable connector (5) with key in receptacle (6). Plug in connector and screw on tight.
4. Aline slot in chassis wiring connector (7) with key in receptacle (8). Plug in connector and screw on tight.

NOTE

Follow-on Maintenance Action Required:

1. Do polarization procedure. Refer to para 7-3.
2. Reconnect battery ground cable. Refer to para 7-58.
3. Start engine and check that battery-generator indicator is in green area. Stop engine. Refer to TM 9-2320-209-10.
4. Close hood and left side panel. Refer to TM 9-2320-209-10.

END OF TASK

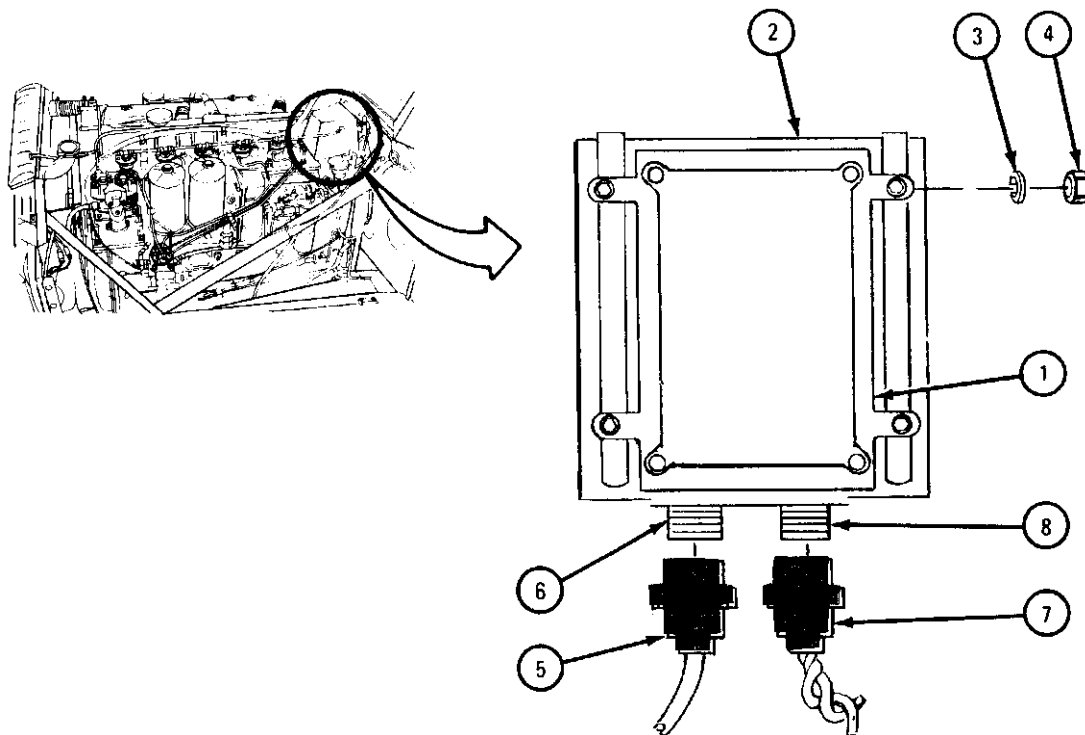

TA 047114

Section III. STARTING SYSTEM

7-6. STARTER PEDAL AND LINKAGE ASSEMBLY REMOVAL, REPAIR, AND REPLACEMENT.

TOOLS : 7/16-inch socket wrench
7/16-inch open end wrench

SUPPLIES: None

PERSONNEL: Two

EQUIPMENT CONDITION: Truck parked, engine off, handbrake set.

a. Preliminary Procedures.

- (1) Open hood and side panels. Refer to TM 9-2320-209-10.
- (2) Disconnect battery ground cable. Refer to para 7-58.

b. Removal.

FRAME 1

- Soldier A 1. Using 7/16-inch wrench, hold four bolts (1) while soldier B unscrews locknuts (2).
- Soldier B 2. Using 7/16-inch wrench, unscrew and take off four locknuts (2) and take off mounting plate (3).
- Soldier A 3. Take out four bolts (1) and lift off pedal assembly (4).
4. Using 7/16-inch wrench, hold two bolts (5) while soldier B unscrews locknuts (6).
- Soldier B 5. Using 7/16-inch wrench, unscrew and take off two locknuts (6).
- Soldier A 6. Take out two bolts (5).
- GO TO FRAME 2

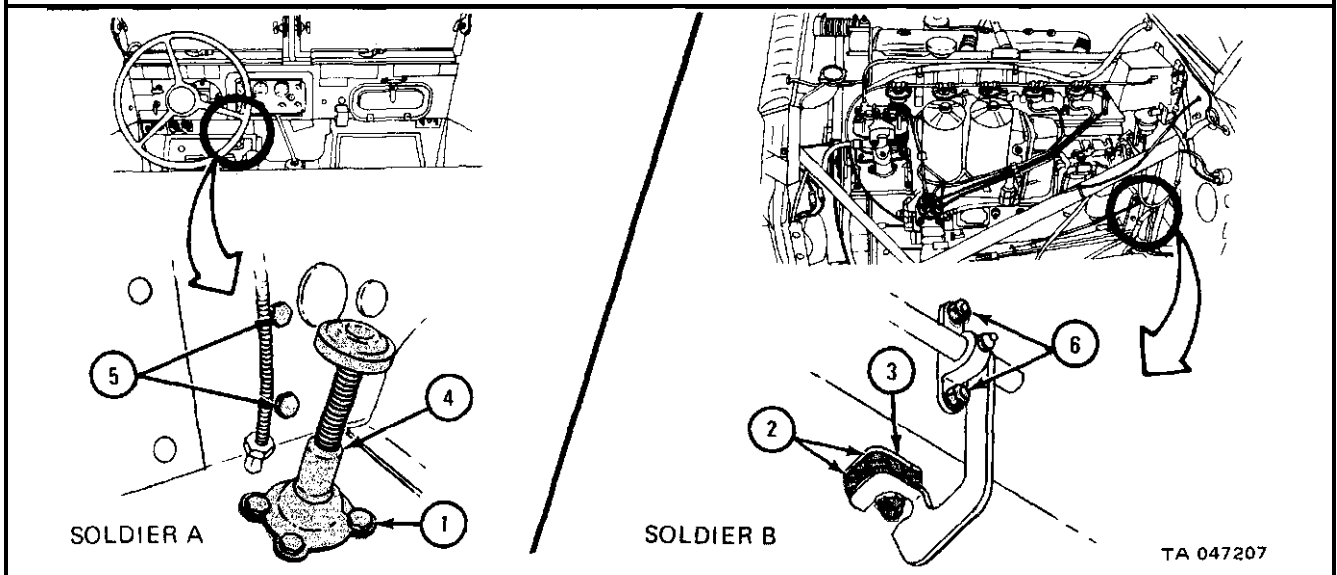

FRAME 2

- Soldier A 1. Using 7/16-inch wrench, hold two bolts (1) while soldier B unscrews locknuts (2).
- Soldier B 2. Using 7/16-inch wrench, unscrew and take off two locknuts (2).
- Soldier A 3. Take out two bolts (1).
- Soldier B 4. Take linkage assembly (3) out of engine compartment.
- END OF TASK

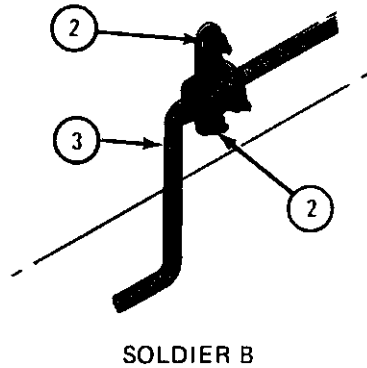
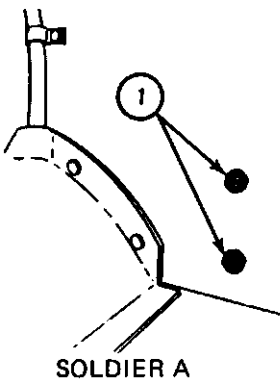
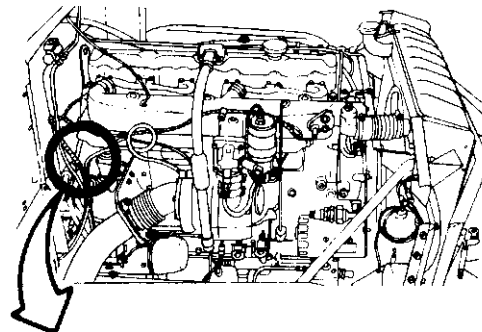
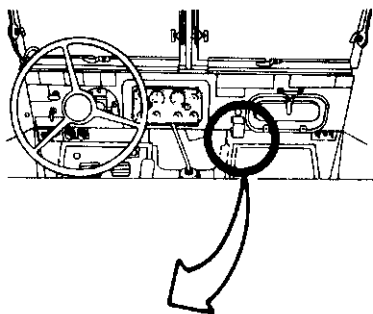

TA 047208

c. Repair. Repair starter pedal and linkage by straightening, welding, or replacing any bent or damaged parts. Refer to FM 43-2 or TM 9-237.

d. Replacement.

FRAME 1

- Soldier A 1. Put starter pedal (1) on floor of cab and aline four mounting holes as shown.
2. Put four bolts (2) through mounting holes. Hold bolts down with fingers and tell soldier B to put on mounting plate (3).
- Soldier B 3. Put mounting plate (3) on four bolts (2) and screw on four locknuts (4) finger tight. Tell soldier A which bolt to hold with wrench when ready to tighten locknuts.
- Soldier A 4. Using 7/16-inch wrench, hold each of four bolts (2).
- Soldier B 5. Using 7/16-inch wrench, tighten each of four locknuts (4).
- GO TO FRAME 2

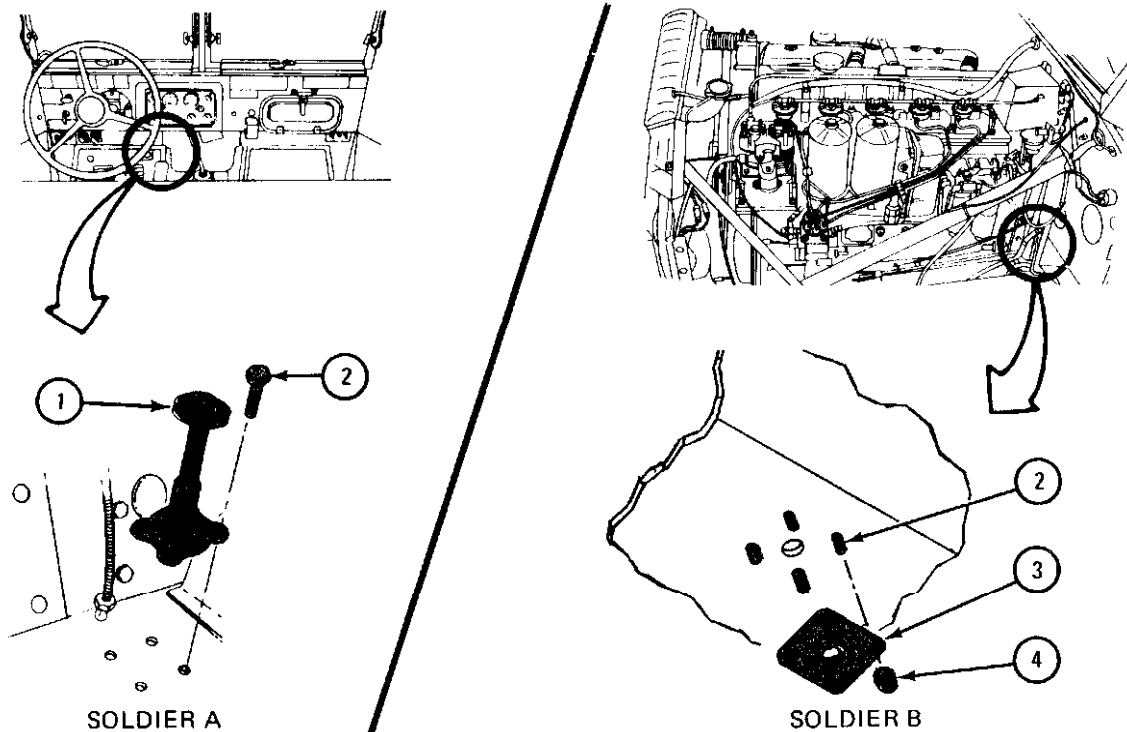

TA 047209

FRAME 2

1. Put starter linkage assembly (1) in engine compartment behind engine. Brackets (2 and 3) should be flat against firewall (4).
2. Place lever (5) so that it is behind starter lever (6) as shown. Lever (7) must be under mounting plate (8).

GO TO FRAME 3

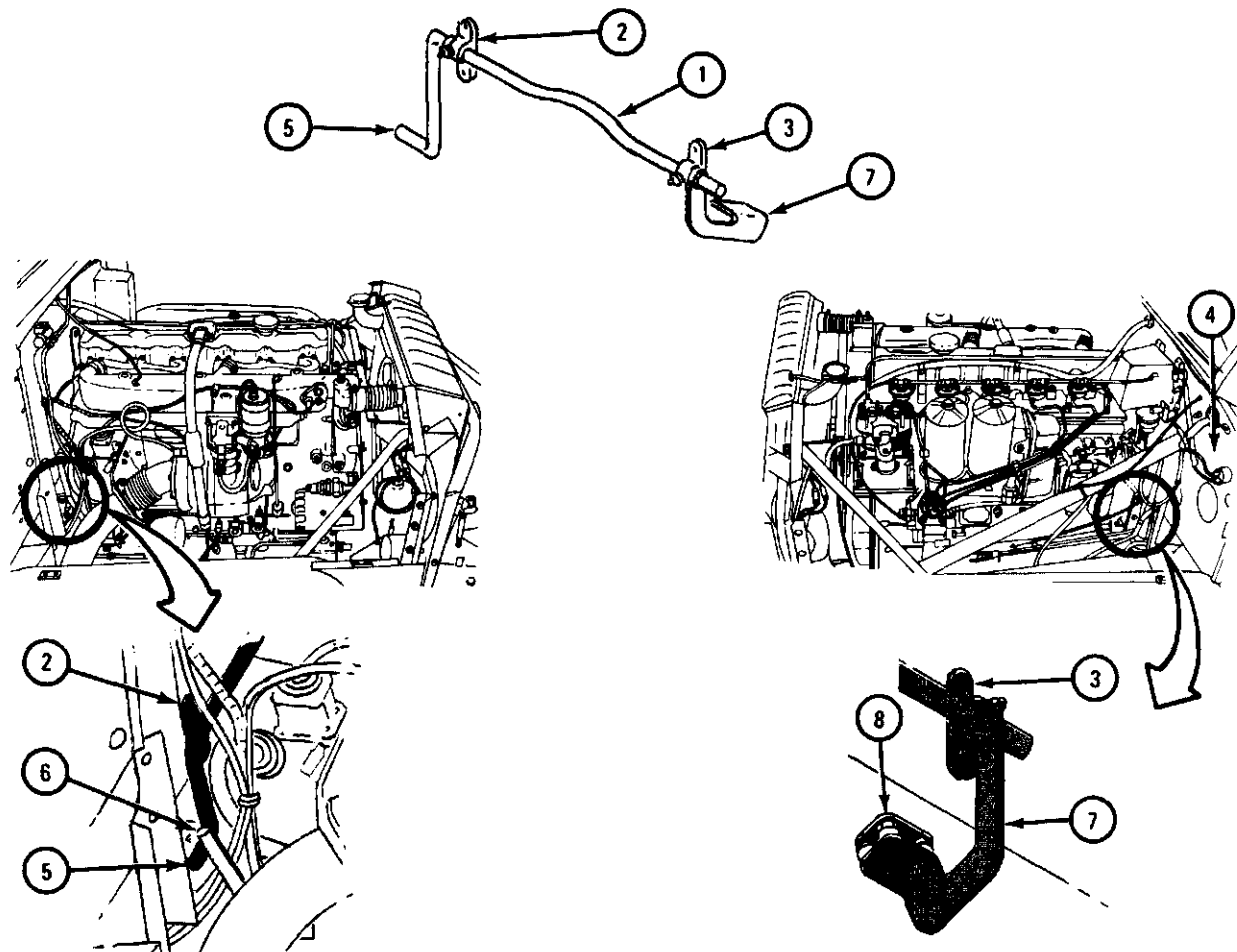

TA 047210

FRAME 3

- Soldier A 1. Hold starter linkage assembly (1) in place so holes in bracket (2) are aligned with holes in firewall (3).
- Soldier B 2. Put two bolts (4) through holes in firewall (3) as shown and, using 7/16-inch wrench, hold bolts while soldier A screws on locknuts (5).
- Soldier A 3. Using 7/16-inch wrench, screw on and tighten two locknuts (5).
- GO TO FRAME 4

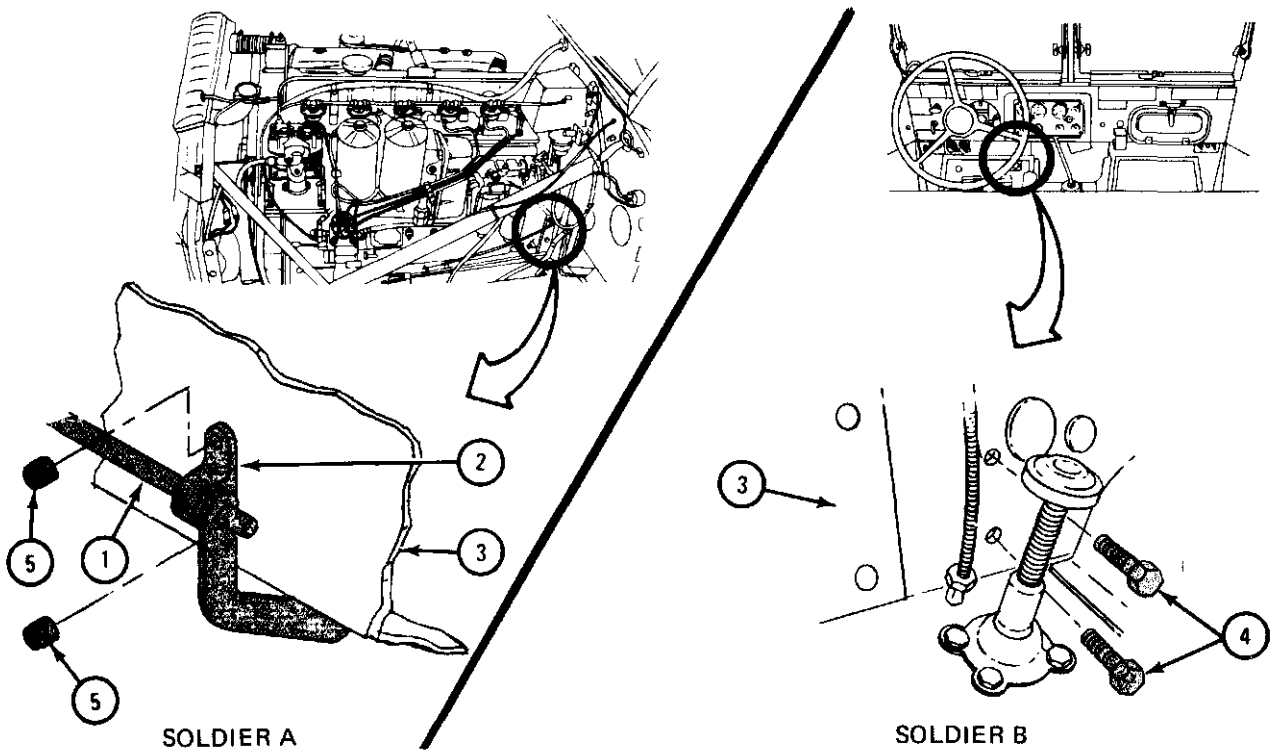

TA 047211

FRAME 4

- Soldier A 1. Aline holes in bracket (1) with holes in firewall (2).
- Soldier B 2. Put two bolts (3) through holes in firewall (2) and using 7/16-inch wrench, hold bolts while soldier A screws on locknuts (4).
- Soldier A 3. Using 7/16-inch wrench, screw on and tighten two locknuts (4).

NOTE

Follow-on Maintenance Action Required:

1. Reconnect battery ground cable. Refer to para 7-58.
2. Test starter pedal and linkage by pushing pedal several times. Check that linkage moves freely without binding.
3. Close hood and slide panels. Refer to TM 9-2320-209-10.

END OF TASK

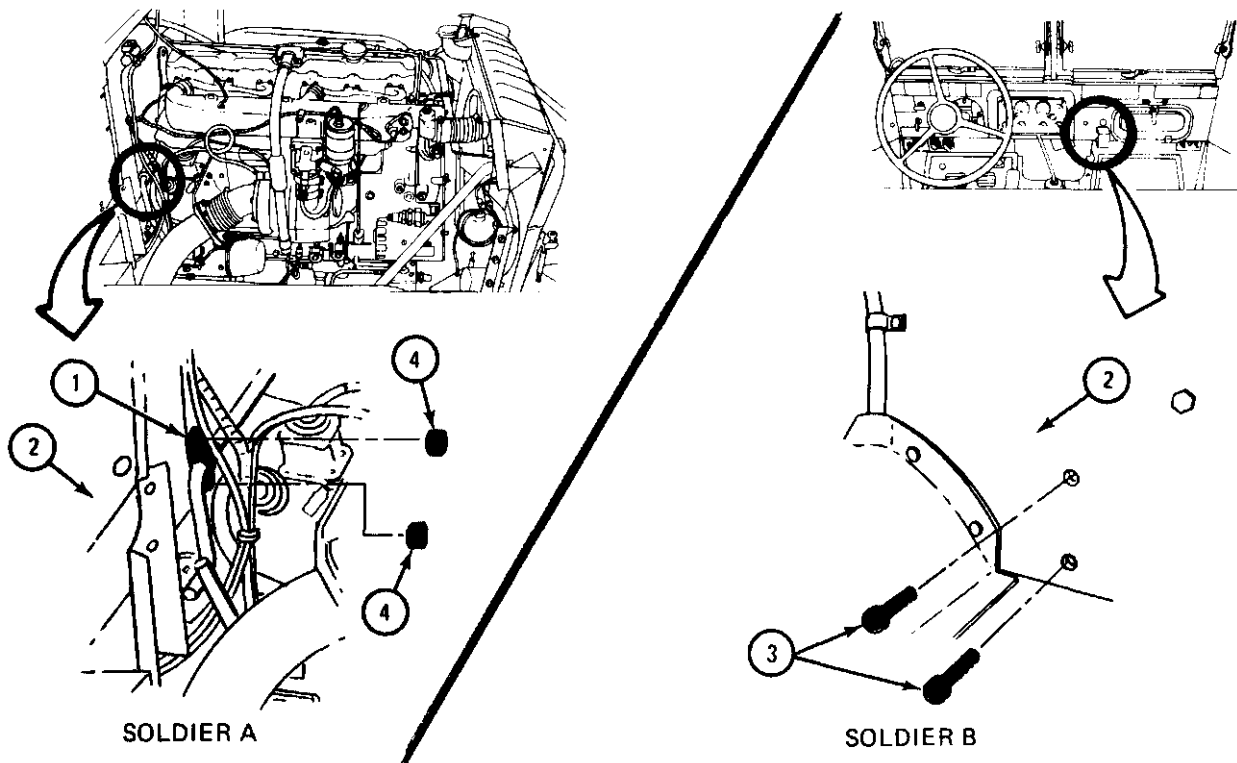

TA 047212

7-7. MAGNETIC STARTER SWITCH REMOVAL AND REPLACEMENT.

TOOLS: 3/8-inch wrench
5/8-inch wrench
7/16-inch wrench

SUPPLIES: None

PERSONNEL: One

EQUIPMENT CONDITION: Truck parked, engine off, handbrake set.

a. Preliminary Procedures.

- (1) Disconnect battery ground cable. Refer to para 7-58.
- (2) Remove air cleaner filter element. Refer to TM 9-2320-209-10.

b. Removal.

NOTE

When taking electrical cables off posts, always tag cables so they will be put back on correct post .

On trucks with LD series engines, magnetic switch mounting bracket is mounted on engine. Trucks with LDS series engine have bracket mounted on exhaust support bracket as shown.

FRAME 1

1. Using 7/16-inch wrench, unscrew and take off two nuts and lockwashers (1).
2. Pull out magnetic starter switch (2).
3. Using 3/8-inch wrench, unscrew and take off nut (3) and take off cable (4).
4. Using 5/8-inch wrench, unscrew two nuts (5) and take off cables (6 and 7). Take magnetic starter switch (2) from truck.

NOTE

Trucks with pedal starter have only one cable (7).

GO TO FRAME 2

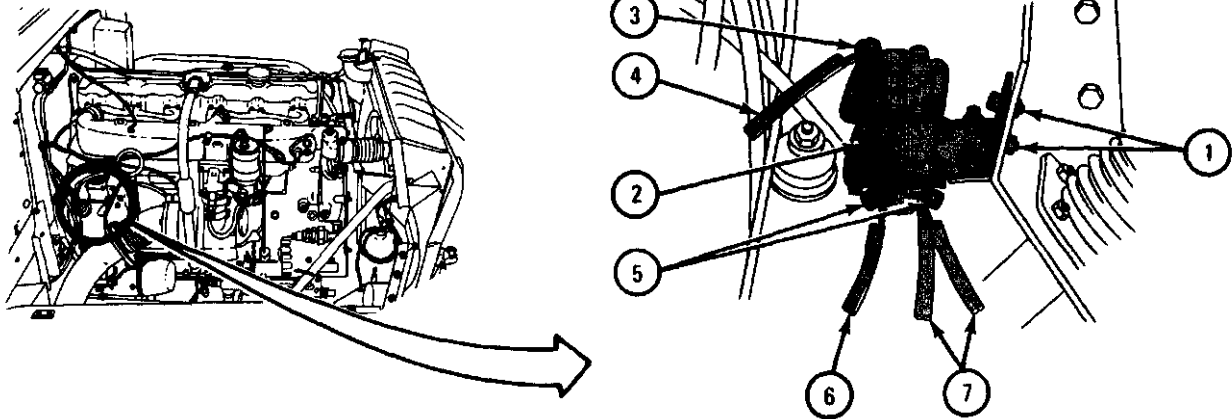

TA 047158

FRAME 2

1. Using 7/16-inch wrench, unscrew and take off two locknuts (1) and two bolts (2).
2. Take magnetic starter switch (3) off bracket (4).

END OF TASK

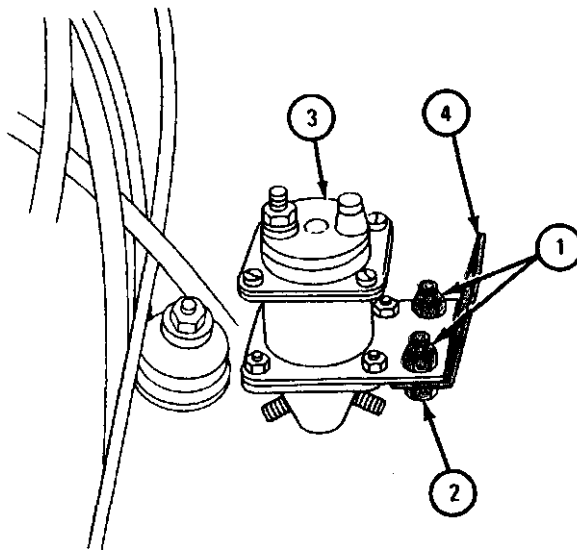

TA 047159

c. Replacement.

FRAME 1

1. Put magnetic starter switch (1) on bracket (2) and align mounting holes.
2. Put two bolts (3) through holes as shown and screw on two locknuts (4).
3. Using 7/16-inch wrench, tighten two locknuts (4).

GO TO FRAME 2

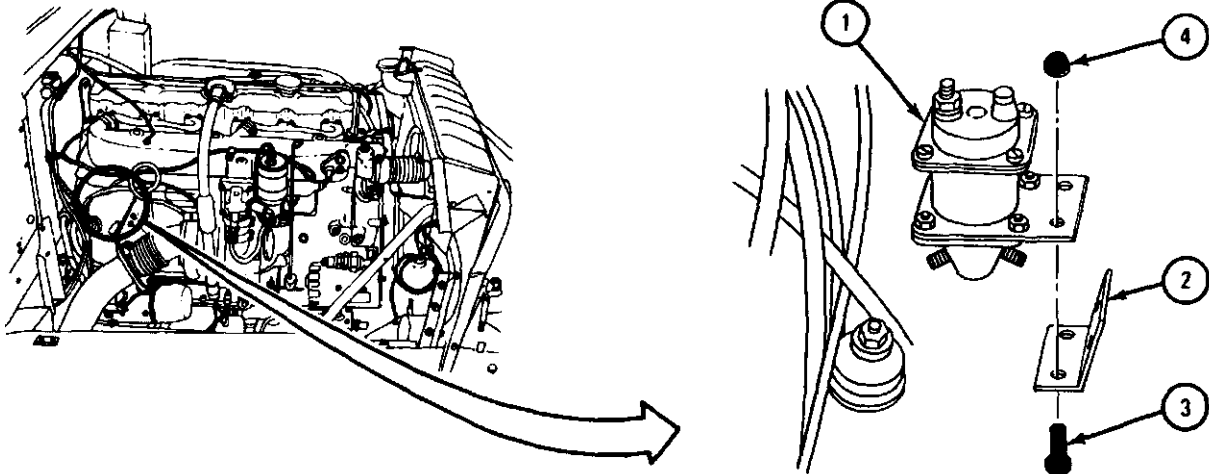

TA 047160

FRAME 2

NOTE

Check tags on cables to make sure cables are put back on right posts.

- 1. Put on cable (1) and lockwasher (2) and screw on nut (3). Using 3/8-inch wrench, tighten nut.

NOTE

Trucks equipped with pedal starter have only one cable (4).

- 2. Put on two cables (4) and lockwasher (5) and screw on nut (6). Using 5/8-inch wrench, tighten nut.
- 3. Put on cable (7) and lockwasher (5) and screw on nut (6). Using 5/8-inch wrench, tighten nut.

GO TO FRAME 3

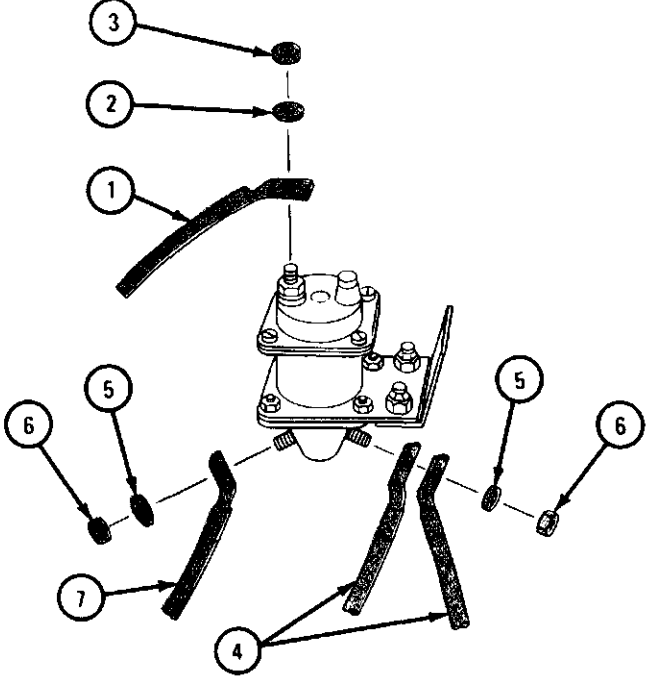

TA 047161

FRAME 3

1. Place magnetic starter switch (1) on exhaust support bracket (2) and aline holes.
2. Put in two bolts (3) and screw on two nuts (4).
3. Using 7/16-inch wrench, tighten two nuts (4).

NOTE

Follow-on Maintenance Action Required:

1. Reconnect battery ground cable. Refer to para 7-58.
2. Operate starter. Refer to TM 9-2320-209-10.
3. Replace air cleaner filter element. Refer to TM 9-2320-209-10.

END OF TASK

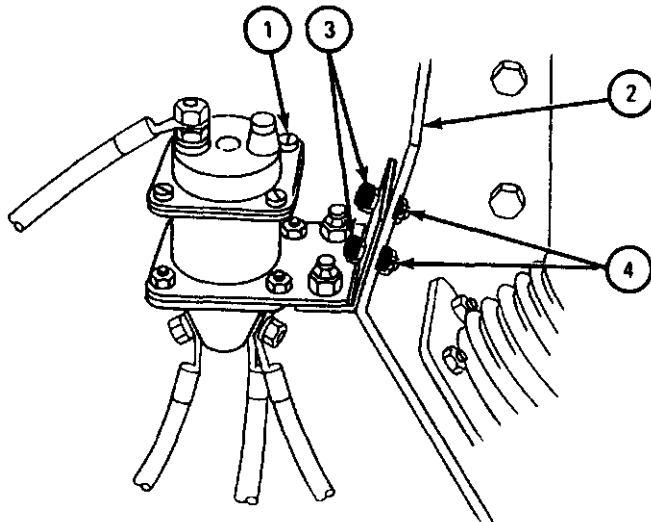

TA 101532

7-8. STARTER SWITCH REMOVAL, REPLACEMENT AND ADJUSTMENT (TRUCKS WITH PEDAL STARTER).

TOOLS: 5/8-inch box wrench
1/2-inch wrench
Flat-tip screwdriver
C-clamp

SUPPLIES: Tags

PERSONNEL: One

EQUIPMENT CONDITION: Truck parked, engine off, handbrake set.

a. Preliminary Procedures.

(1) Remove air cleaner filter element. Refer to TM 9-2320-209-10.

(2) Disconnect battery ground cable. Refer to para 7-58.

NOTE

When taking electrical cables off posts, always tag cables so they will be put back on right post.

b. Removal.

FRAME 1

1. Using 5/8-inch wrench, unscrew and take off two nuts and washers (1).
2. Lift cables (2 and 3) off starter switch (5).
3. Using screwdriver, unscrew and take out four screws with lockwashers (4).
4. Lift off starter switch (5).

END OF TASK

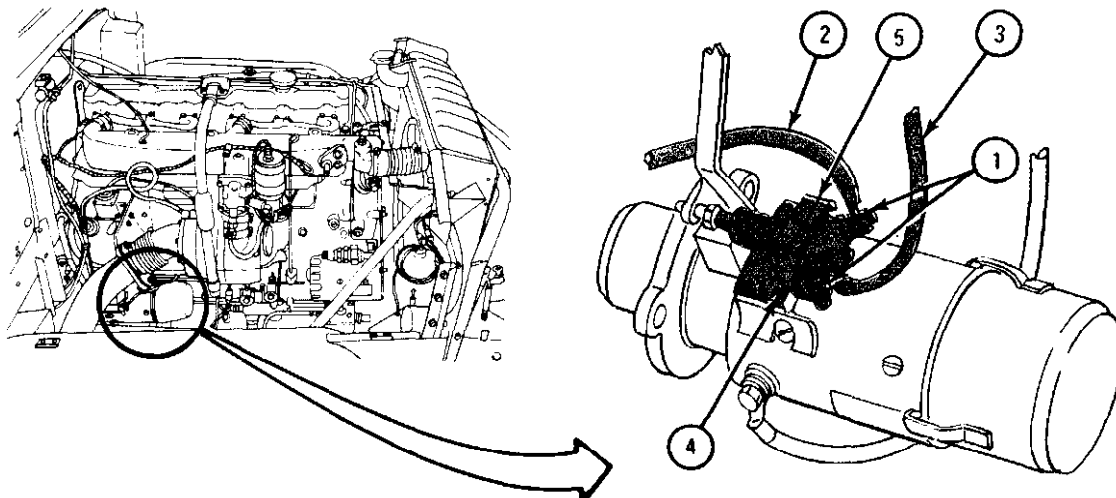

TA 047153

FRAME 1

1. Put starter switch (1) on mounting plate (2) and align four mounting holes.
2. Using screwdriver, screw in and tighten four screws (3) with lockwashers (4).

GO TO FRAME 2

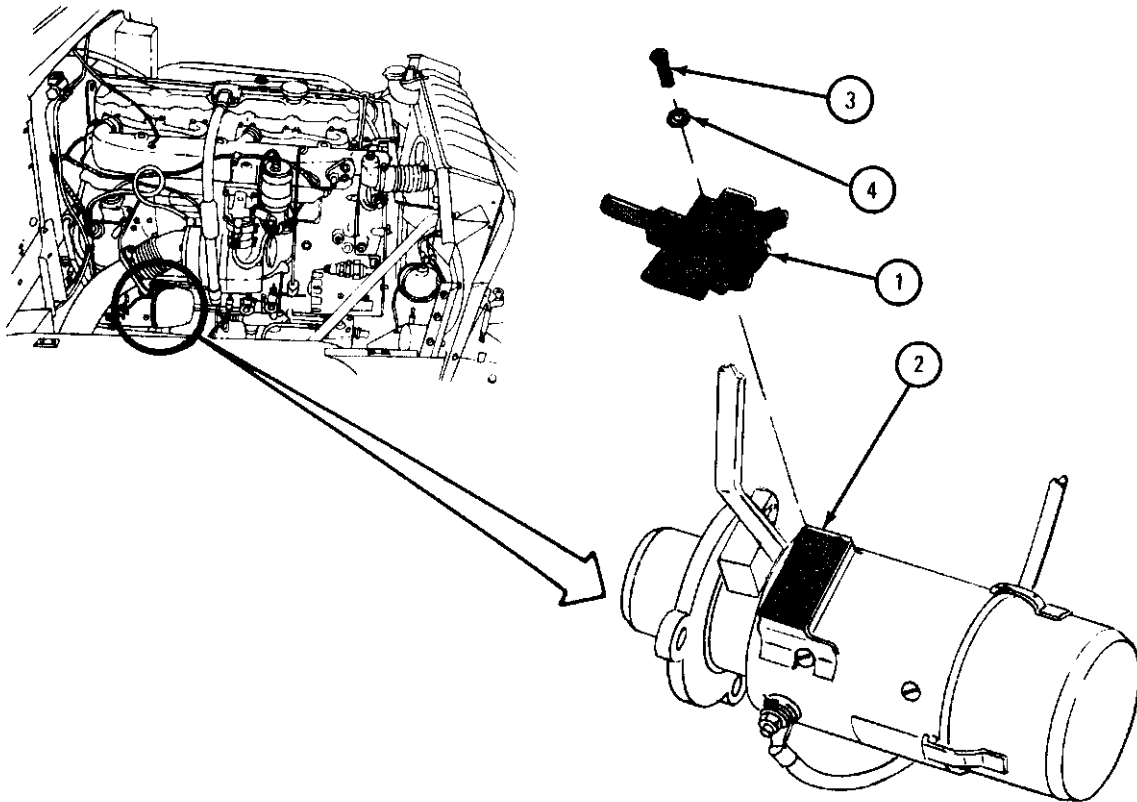

TA 047154

FRAME 2

NOTE

Check tags on cables (1) to make sure they are put back on right posts (2).

1. Put two cables (1) on two posts (2).
2. Using 5/8-inch wrench, screw on and tighten two nuts (3) with lockwashers (4) on posts (2).

NOTE

Follow-on Maintenance Action Required:

1. Do adjustment procedure. Refer to para 7-8d.
2. Reconnect battery ground cable. Refer to para 7-58.
3. Operate starter. Refer to TM 9-2320-209-10.
4. Replace air cleaner filter element. Refer to TM 9-2320-209-10.

END OF TASK

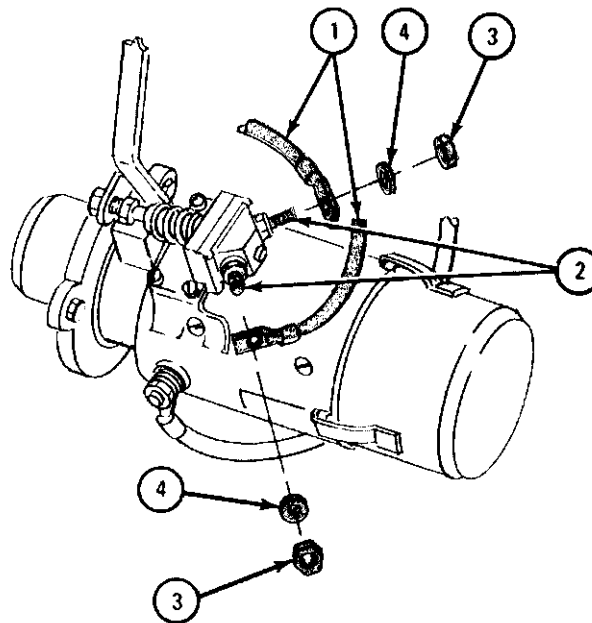

TA 047155

d. Adjustment.

FRAME 1

1. Using 1/2-inch wrench, loosen locknut (1) and screw adjusting bolt (2) all the way in as shown.
2. Using C-clamp, compress switch return spring (3) to close starter switch (4) as shown.

CAUTION

In step 3 do not pull lever any further forward than shown. This could damage spring inside of starter.

3. Move lever (5) forward in direction shown, until it is almost vertical.
4. Move lever (5) back and forth a few times. The lever should move freely without binding.

NOTE

If lever does not move freely, take out starter and tell direct support maintenance. Refer to para 7-10.

GO TO FRAME 2

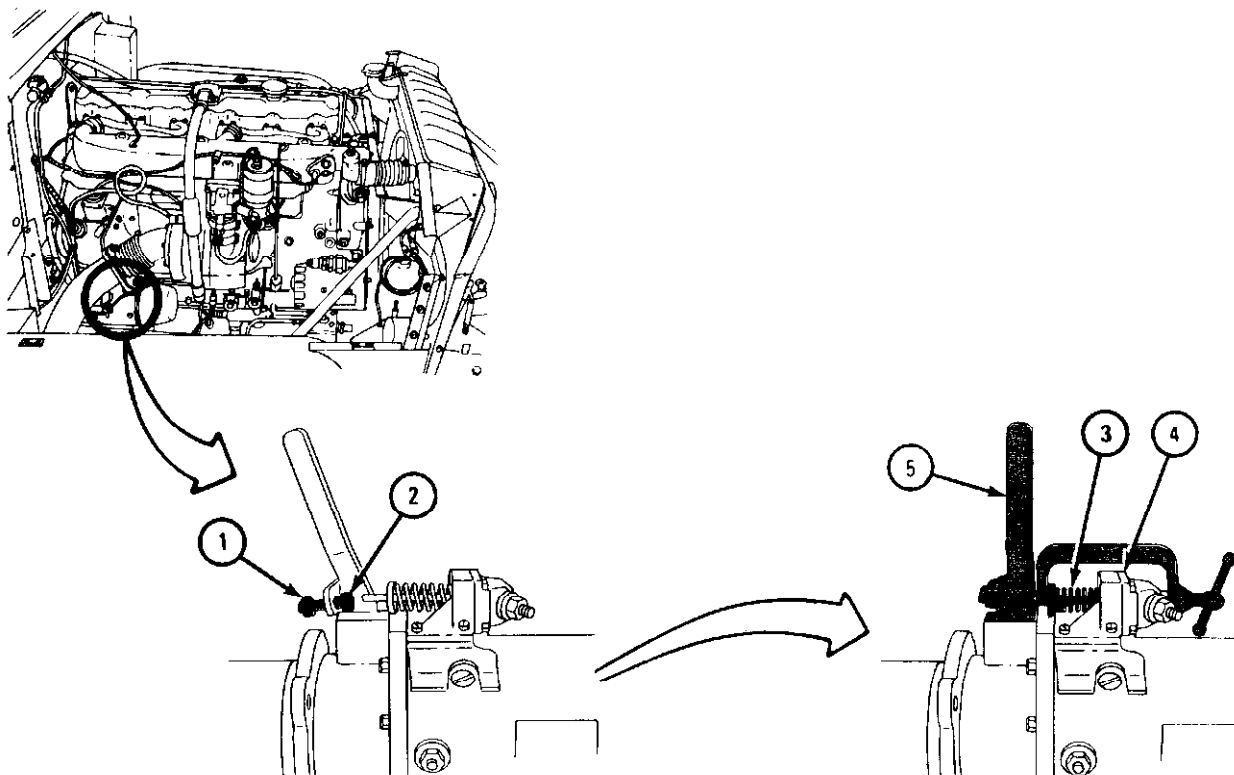

TA 047156

FRAME 2

1. With switch return spring (1) compressed, unscrew adjustment bolt (2). Bolt head should touch switch plunger rod (3).
2. Take C-clamp away, letting switch return spring (1) and lever (4) go back to normal position. Using 1/2-inch wrench, turn adjustment bolt (2) in 1/4 turn.
3. Using 1/2-inch wrench, tighten locknut (5) while holding adjustment bolt (2) with 1/2-inch wrench.

END OF TASK

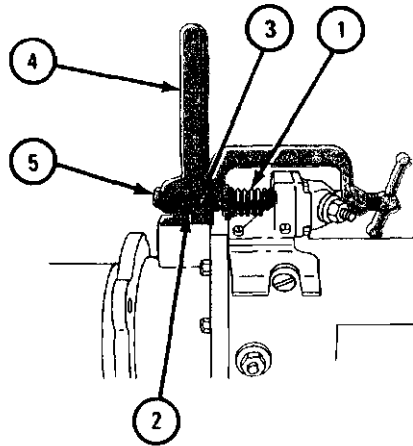

TA 047157

7-9. STARTER BUTTON REMOVAL AND REPLACEMENT.

TOOLS: 13/16-inch wrench

SUPPLIES: None

PERSONNEL: One

EQUIPMENT CONDITION: Truck parked, engine off, handbrake set.

- a. Preliminary Procedure. Disconnect battery ground cable. Refer to para 7-58.
- b. Removal.

FRAME 1

1. Hold back of engine starter switch (1).
2. Using 13/16-inch wrench, unscrew and take off nut (2).
3. Take off plate (3).
4. Push starter switch (1) through instrument panel (4).
5. Pull plug (5) out of switch (1).

END OF TASK

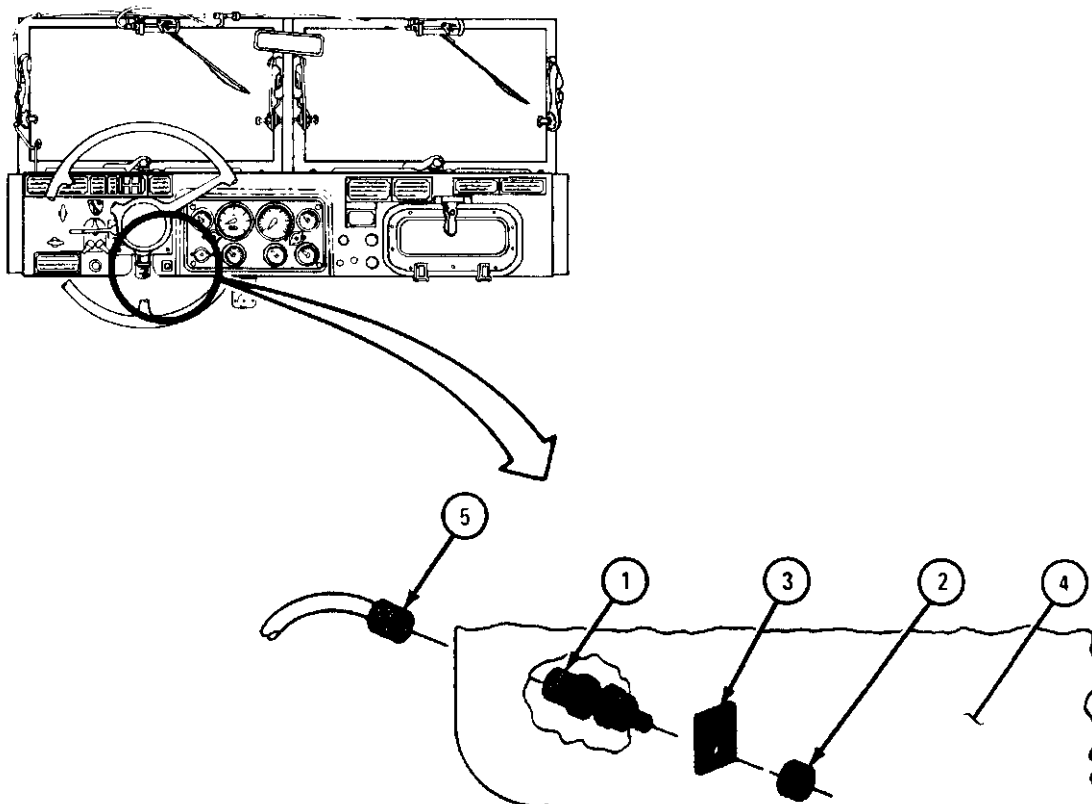

TA 104762

Replacement.**FRAME 1**

1. Put plug (1) into switch (2).
2. Put starter switch (2) through instrument panel (3).
3. Put plate (4) on switch (2).
4. Hold back of switch (2) in place.
5. Using 13/16-inch wrench, screw on and tighten nut (5).

NOTE

Follow-on Maintenance Action Required:

Reconnect battery ground cable. Refer to para 7-58.

END OF TASK

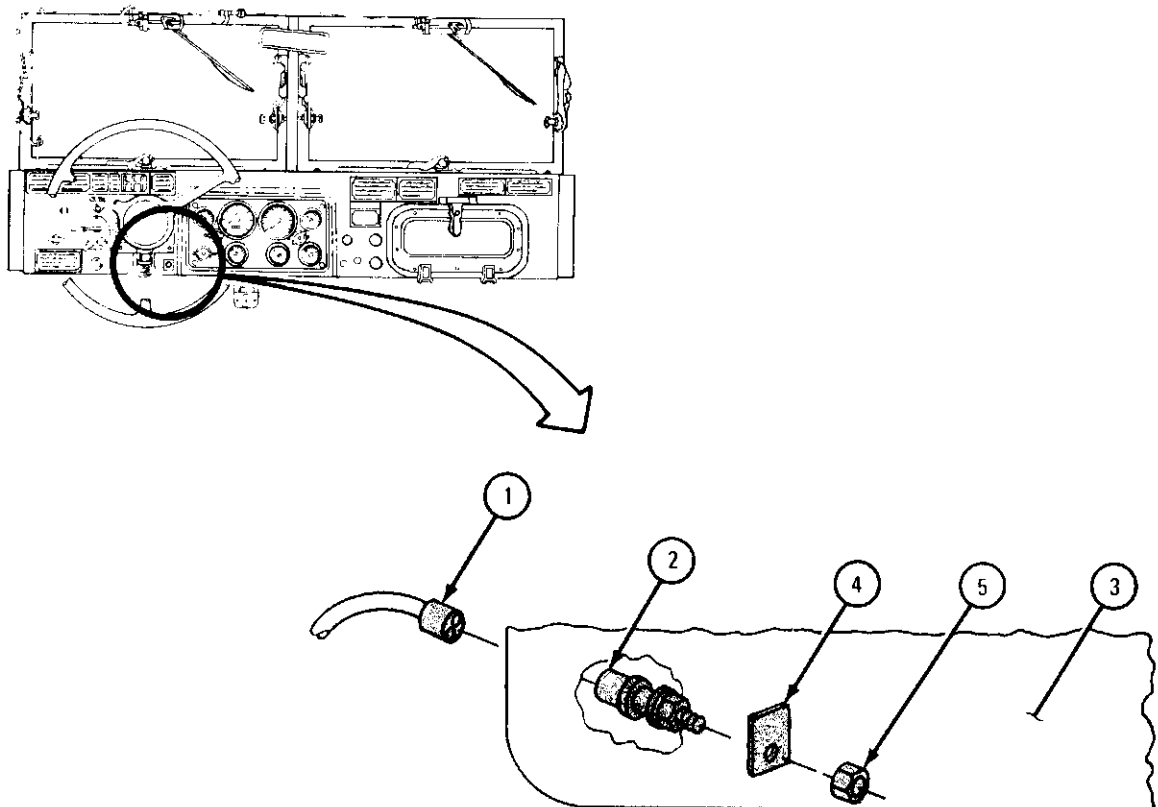

TA 104763

7-10. ENGINE STARTER REMOVAL AND REPLACEMENT (TRUCKS WITH FLOOR PEDAL STARTER SWITCH).

TOOLS: 5/8-inch open end wrench
15/16-inch wrench

SUPPLIES: Starter gasket
Starter adapter gasket
Solvent, dry cleaning, type II (SD-2), Fed. Spec P-D-680

PERSONNEL: One

EQUIPMENT CONDITION: Truck parked, engine off, handbrake set.

a. Preliminary Procedures.

- (1) Disconnect battery ground cable. Refer to para 7-58.
- (2) Remove intake air cleaner. Refer to para 4-3.

b. Removal.

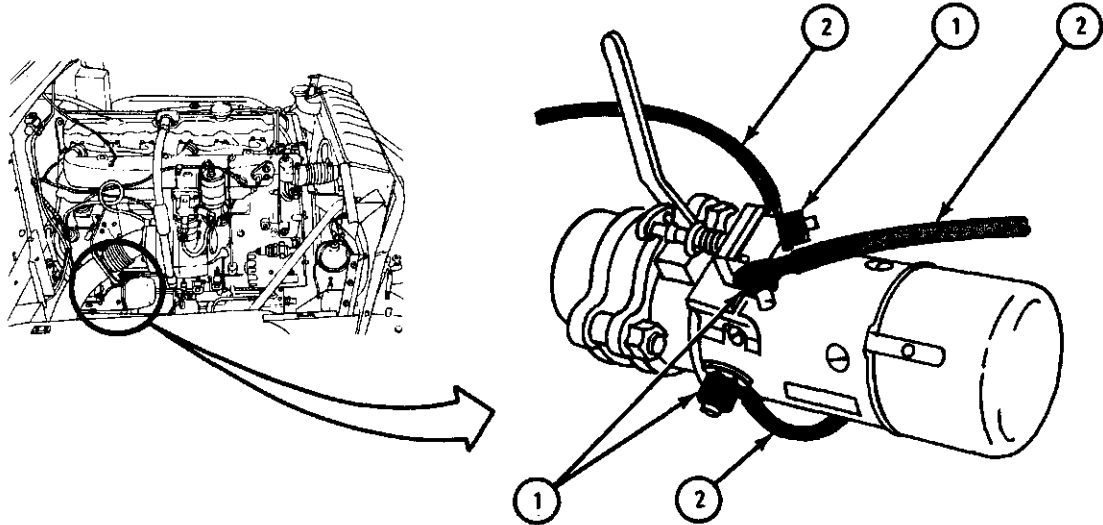
FRAME 1
<ol style="list-style-type: none">1. Using 5/8-inch wrench, unscrew and take off three nuts and three lockwashers (1).2. Tag electrical cables (2) so that they will be put back in the same place.3. Lift off three cables (2). <p>GO TO FRAME 2</p>
 <p style="text-align: right;">T/I 047085</p>

FRAME 2

1. Using 15/16-inch wrench, unscrew and take off three nuts (1) and three lockwashers (2).
2. Pull starter (3) straight out of flywheel housing (4) until starter drive gear is free.
3. Take out starter (3).
4. Check that teeth of starter drive gear on end of starter (3) are not damaged. If teeth are damaged, tell direct support maintenance.

GO TO FRAME 3

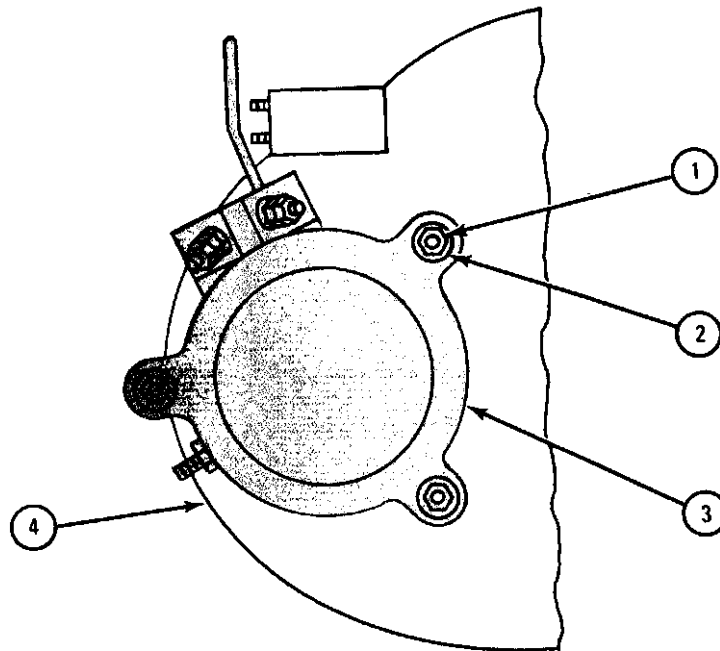

TA 047086

FRAME 3

1. Pull starter gasket (1) off three studs (2) and throw gasket away.
2. Pull starter adapter (3) off three studs (2) and set adapter aside.
3. Pull adapter gasket (4) off three studs (2) and throw gasket away.
4. Check that flywheel ring gear (5) has no damaged teeth. If teeth are damaged, tell direct support maintenance.

END OF TASK

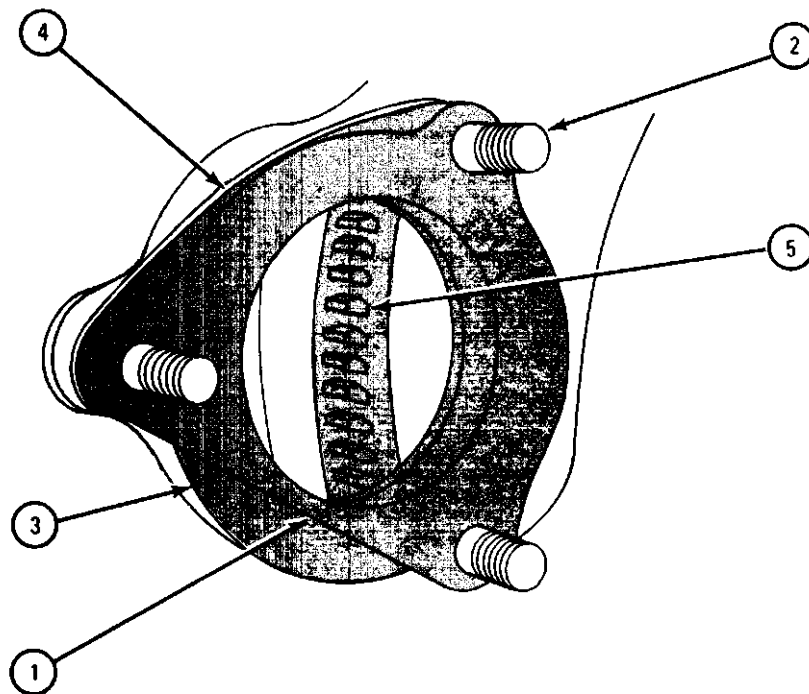

TA 047087

c. Replacement.**FRAME 1**

1. Put starter adapter gasket (1) over three studs (2) and against mounting flange (3). Straight edge of gasket must be at bottom.

WARNING

Dry cleaning solvent is flammable. Do not use near an open flame. Keep a fire extinguisher nearby when solvent is used. Use only in well-ventilated places. Failure to do this may result in injury to personnel and damage to equipment.

2. Before putting in starter, using solvent, clean starter adapter (4) of starter.
3. Put starter adapter (4) over three studs (2) and against starter adapter gasket (1).
4. Put starter gasket (5) over three studs (2) and against starter adapter (4). Straight edge of gasket must be at bottom as shown.

GO TO FRAME 2

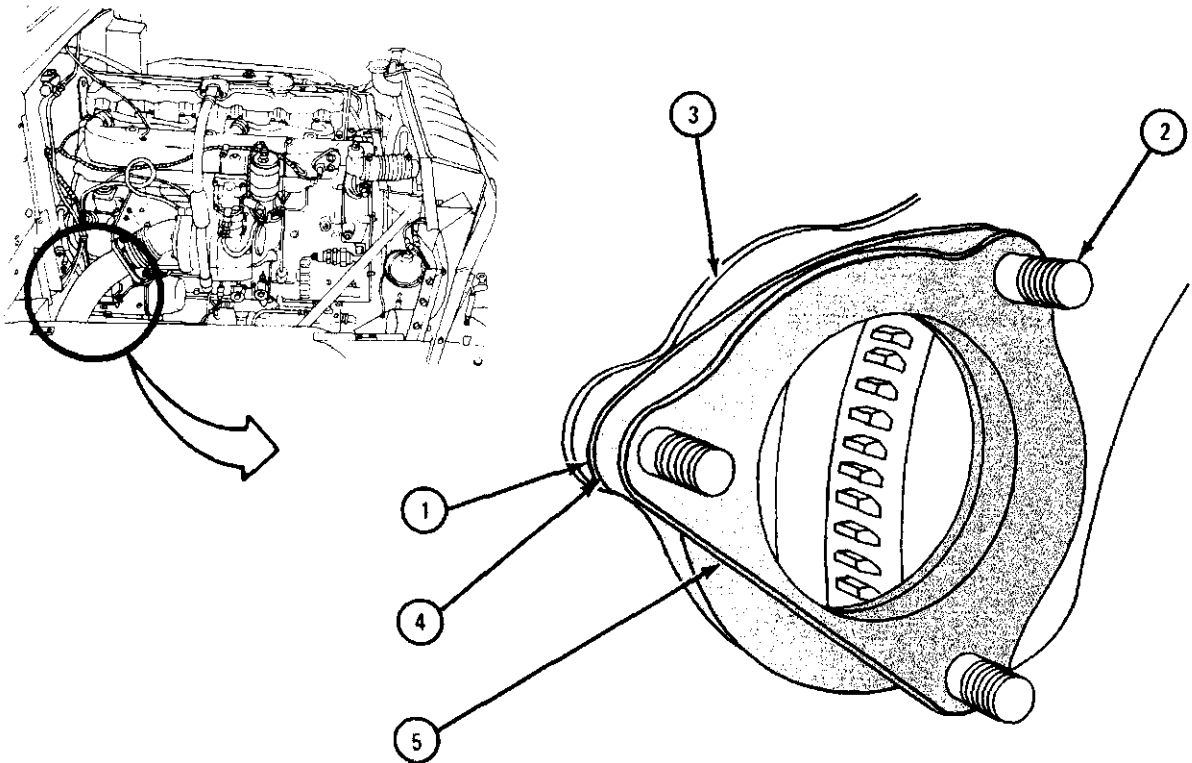

TA 047088

FRAME 2

1. Put starter (1) in position. Align three holes in starter mounting flange (2) with mounting studs (3). Lever (4) must be at top as shown.

NOTE

If starter (1) will not seat firmly against adapter, do not force it. It may be due to gear position. Take starter out, turn starter drive gear slightly, and try again.

2. Push starter (1) straight in on mounting studs (3) until it is firmly seated. Put three lockwashers (5) on three mounting studs.
3. Screw on and hand tighten three nuts (6) onto three mounting studs (3).
4. Using 15/16-inch wrench, evenly tighten three nuts (6).

GO TO FRAME 3

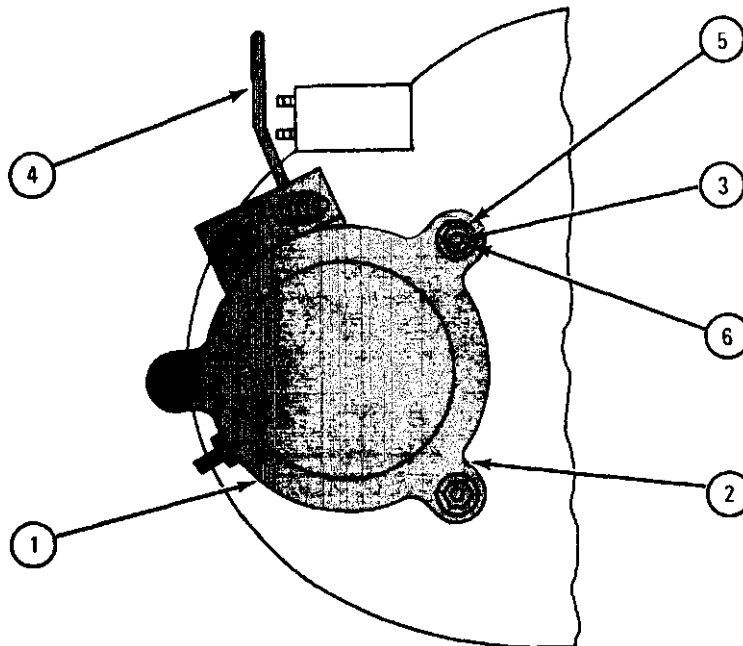

TA 047089

FRAME 3

1. Put on three cables (1) as tagged.
2. Using 5/8-inch wrench, screw on and tighten three nuts and lockwashers (2). Take off tags.

NOTE

Follow-on Maintenance Action Required:

1. Reconnect battery ground cable. Refer to para 7-58.
2. Start truck several times. Refer to TM 9-2320-209-10.
3. Replace intake air cleaner. Refer to para 4-3.

END OF TASK

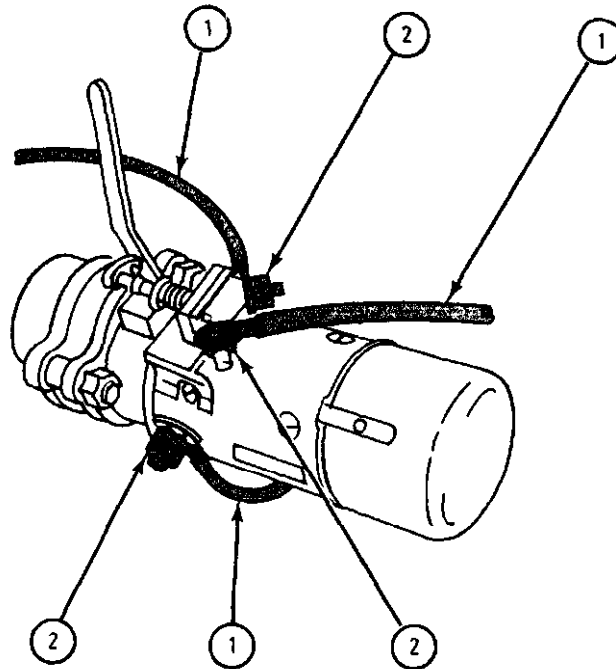

TA 047090

FRAME 2

1. Tag cables so that they will be put back in the same place.
2. Using 3/4-inch wrench, unscrew and take off nut and lockwasher (1). Lift off cable (2).
3. Using 3/4-inch wrench, unscrew and take off nut and lockwasher (3). Lift off three cables (4).
4. Using screwdriver, unscrew and take out screw and lockwasher (5). Lift off small cable (6).

GO TO FRAME 4

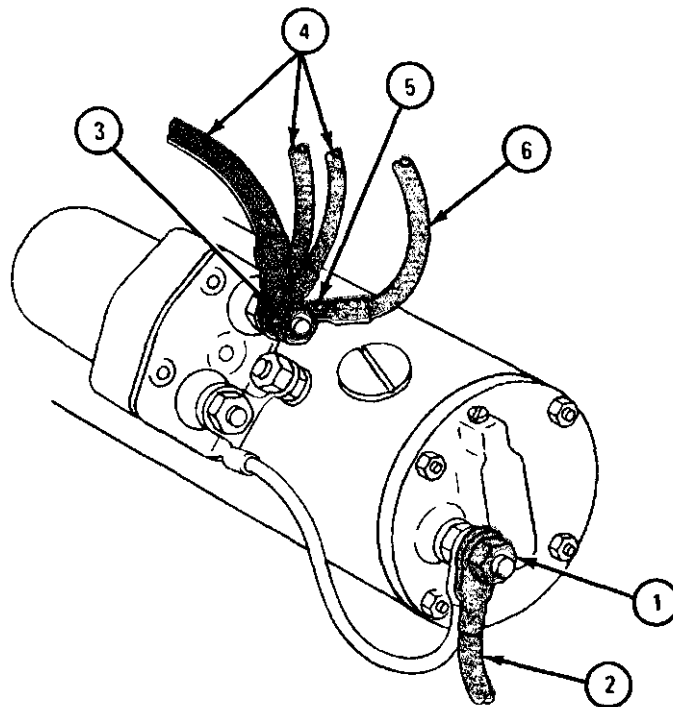

TA 047092

FRAME 3

1. Tag cables so that they will be put back in the same place.
2. Using 7/8-inch wrench, unscrew and take off nut (1). Lift off three cables (2).
3. Using 7/8-inch wrench, unscrew and take off nut (3). Lift off cable (4).
4. Using 3/8-inch wrench, unscrew and take off nut and lockwasher (5). Lift off small cable (6).

GO TO FRAME 4

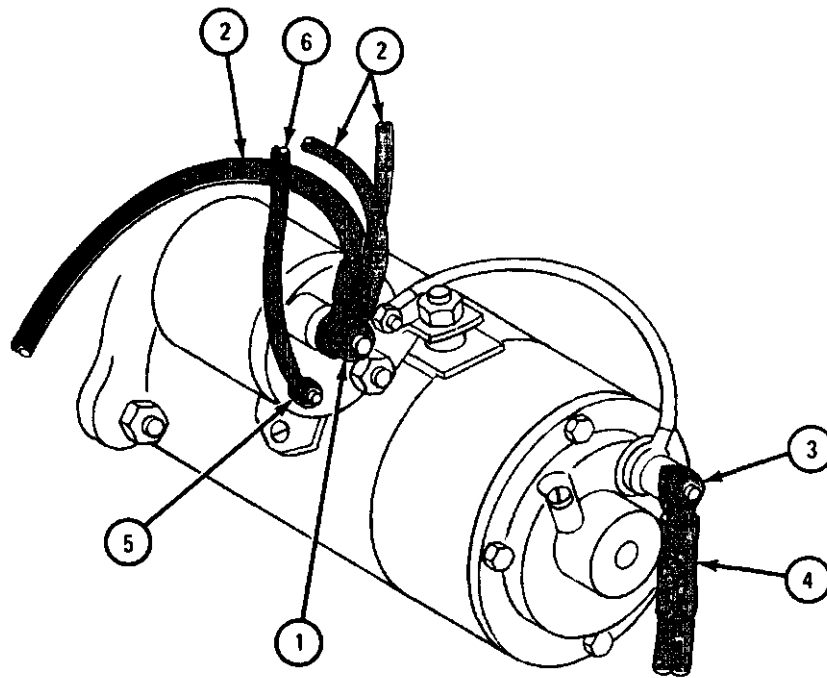

TA 047093

FRAME 4

1. Using 15/16-inch socket wrench, unscrew and take off three nuts and lock-washers (1).

CAUTION

Starter (2) weighs 50 pounds. Be careful to hold up starter when taking starter off mounting studs to keep it from falling.

- 2, Pull starter (2) straight out of flywheel housing (3) until starter drive gear is free.
3. Take out starter (2).
4. Check that teeth of starter drive gear on end of starter (2) are not damaged. If teeth are damaged, tell direct support maintenance.

GO TO FRAME 5

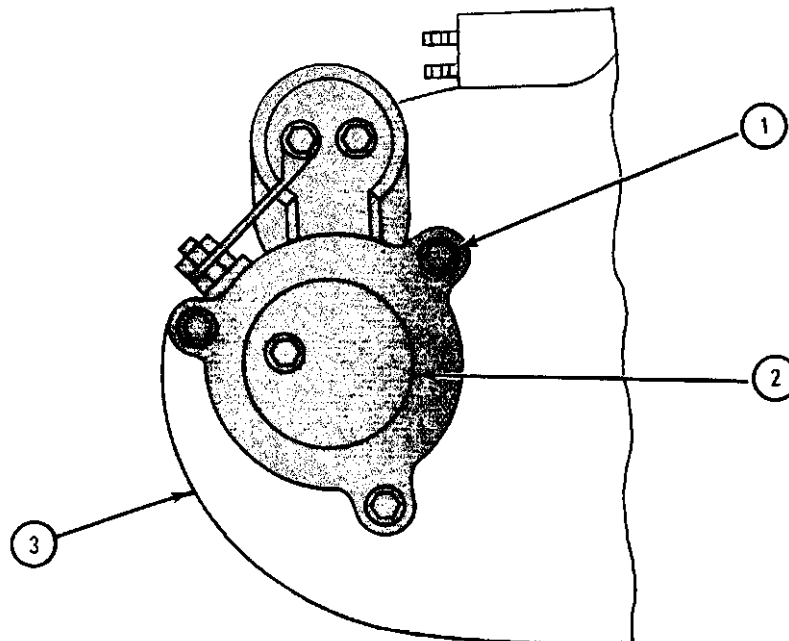

TA 047094

FRAME 5

1. Pull starter gasket (1) off three studs (2) and throw gasket away.
2. Pull starter adapter (3) off three studs (2) and set adapter aside.
3. Pull starter adapter gasket (4) off three studs (2) and throw gasket away.
4. Check that teeth of flywheel ring gear (5) are not damaged. If teeth are damaged, tell direct support maintenance.

END OF TASK

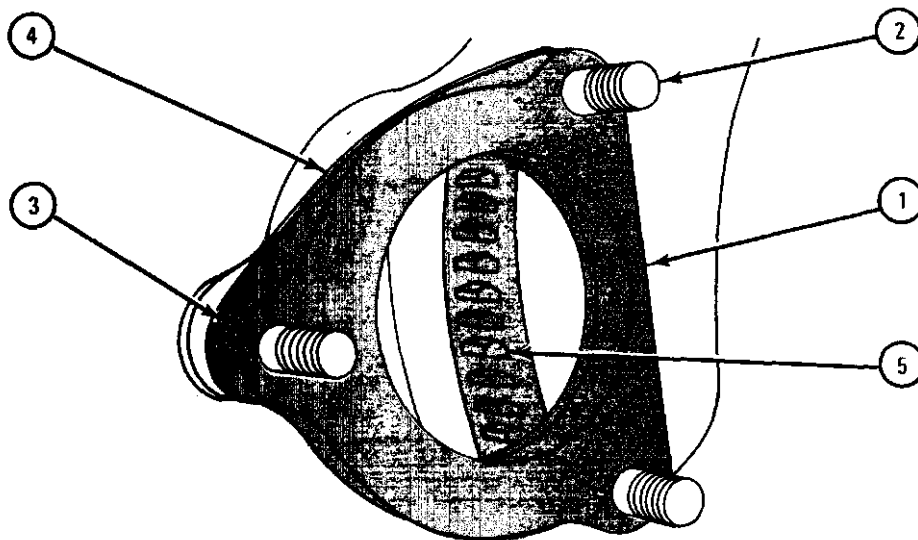

TA 047095

c. Replacement.WARNING

Dry cleaning solvent is flammable. Do not use near an open flame. Keep a fire extinguisher nearby when solvent is used. Use only in well-ventilated places. Failure to do this may result in injury to personnel and damage to equipment.

FRAME 1

1. Put starter adapter gasket (1) over three studs (2) against mounting flange (3). Straight edge of gasket must be a right side.
2. Before putting in starter, using solvent, clean starter adapter (4) and mounting flange of starter.
3. Put starter adapter (4) over three studs (2) against gasket (1).
4. Put starter gasket (5) over three studs (2) and against starter adapter (4). Straight edge of gasket must be at right side as shown.

GO TO FRAME 2

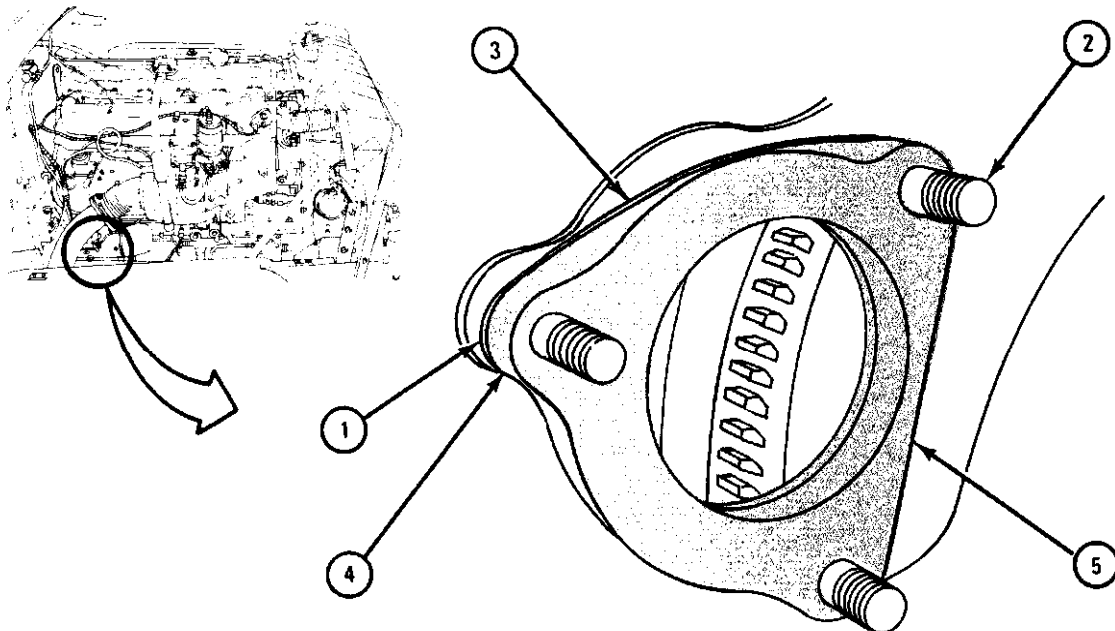

TA 047096

FRAME 2

NOTE

Some starters may be at angle for mounting of left side of engine.

1. Check that position of starter flange to center line of solenoid is as shown. If position is not as shown, do steps 2 and 3. If position is as shown, go to frame 3.
2. Using 3/16-inch allen wrench, unscrew and take out six bolts (1).
3. Turn starter flange (2) on starter housing (3), using solenoid centerline (4) as guide, until it is in position shown. Using 3/16-inch allen wrench, screw in and tighten six bolts (1).

GO TO FRAME 3

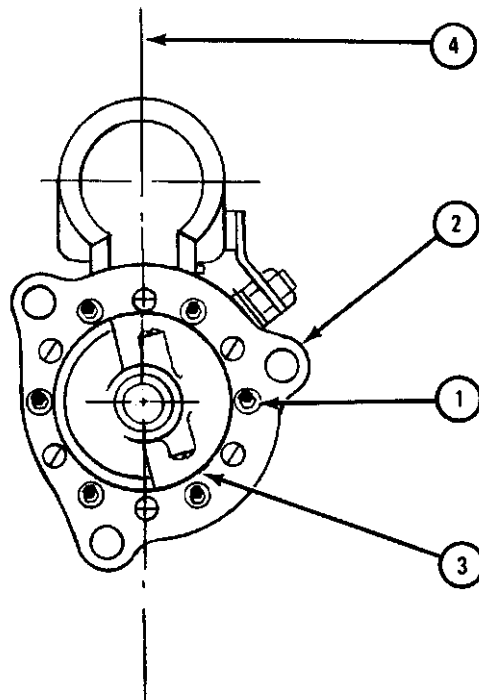

TA 047097

FRAME 3

CAUTION

Starter weighs 50 pounds. Be careful not to let it fall when lifting starter into engine compartment.

NOTE

If starter will not seal firmly against adapter, do not force it. It may be due to gear position. Take starter out, turn starter drive gear slightly, and try again.

1. Put starter (1) in engine compartment. Aline three holes in starter mounting flange (2) with mounting studs (3). Solenoid (4) must be at top as shown.
2. Push starter straight in on mounting studs (3) until it is firmly seated. Put three lockwashers (5) on three mounting studs (3).
3. Screw on and hand tighten three nuts (6) onto three mounting studs (3).
4. Using 15/16-inch socket wrench, evenly tighten three nuts (6).

IF PUTTING BACK STARTER, pn 10911018-1, GO TO FRAME 4.
IF PUTTING BACK STARTER, pn 10935376-1, GO TO FRAME 5

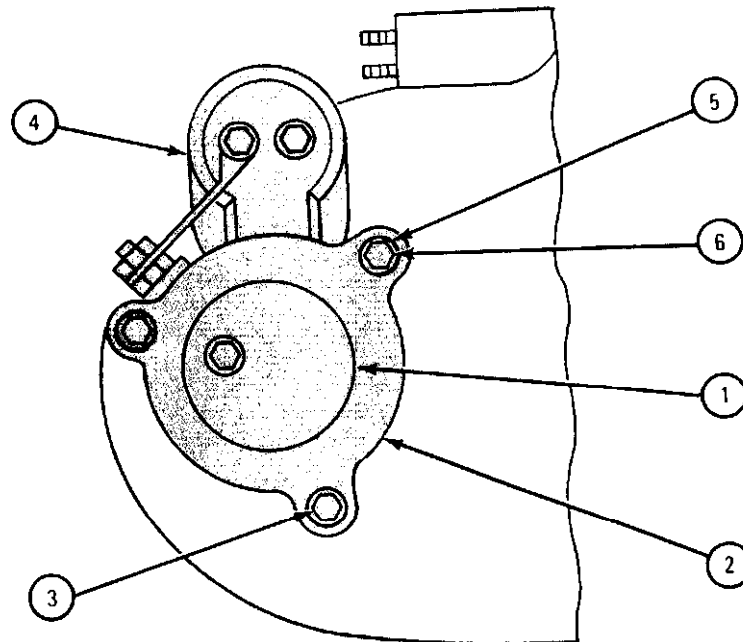

TA 047098

FRAME 4

1. Put on small cable as tagged (1). Using screwdriver, screw in and tighten lockwasher and screw (2). Take off tag.
2. Put on three cables (3) as tagged. Using 3/4-inch wrench, screw on and tighten lockwasher and nut (4). Take off tags.
3. Put on cable (5) as tagged. Using 3/4-inch wrench, screw on and tighten lockwasher and nut (6). Take off tag.

NOTE

Follow-on Maintenance Action Required:

1. Reconnect battery ground cable. Refer to para 7-58.
2. Start truck several times to check starter. Refer to TM 9-2320-209-10.
3. Replace intake air cleaner. Refer to para 4-3.

END OF TASK

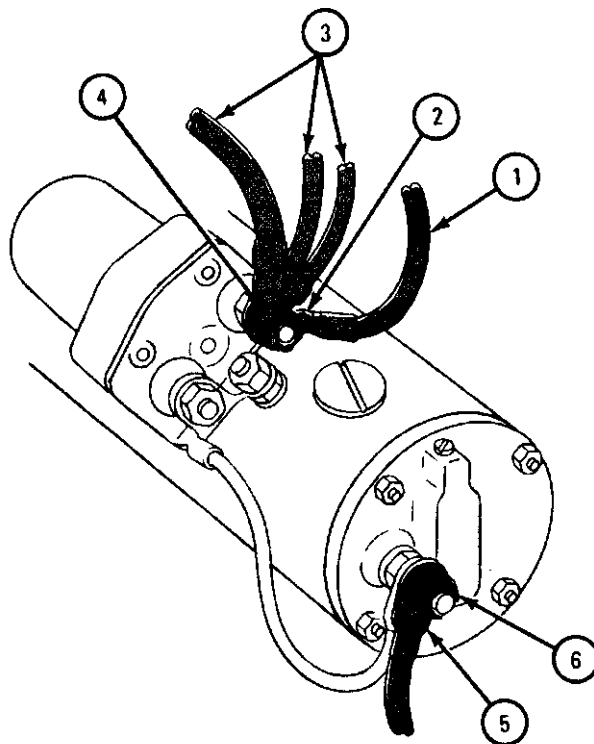

TA 047099

FRAME 5

1. Put on small cable (1) as tagged. Using 3/8-inch wrench, screw on and tighten lockwasher and nut (2). Take off tag.
2. Put on three cables (3) as tagged. Using 7/8-inch wrench, screw on and tighten lockwasher and nut (4). Take off tags.
3. Put on cable (5) as tagged. Using 7/8-inch wrench, screw on and tighten lockwasher and nut (6). Take off tag.

NOTE

Follow-on Maintenance Action Required:

1. Reconnect battery ground cable. Refer to para 7-58.
2. Start truck several times to check starter. Refer to TM 9-2320-209-10.
3. Replace intake air cleaner. Refer to para 4-3.

END OF TASK

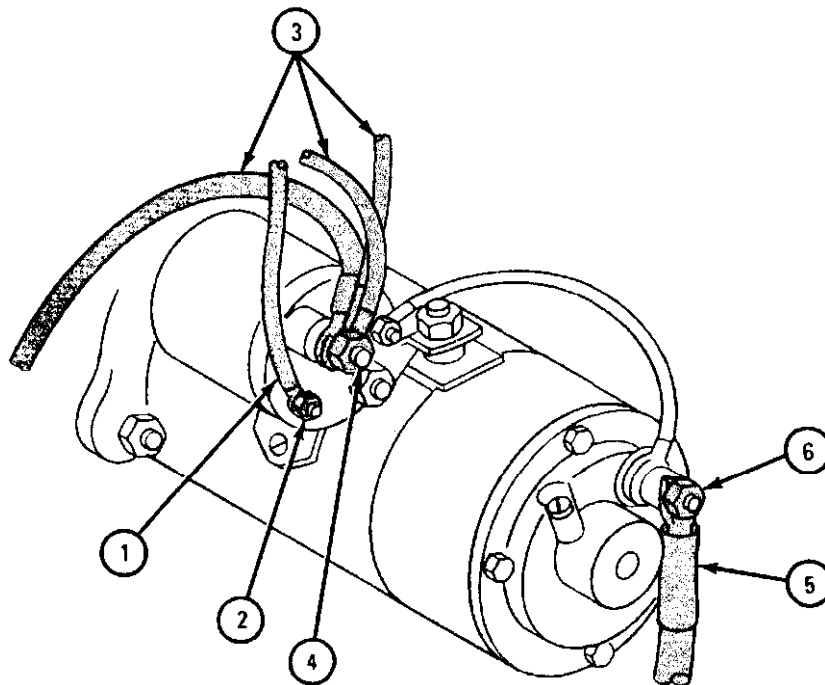

TA 047100

Section IV. INSTRUMENT PANEL COMPONENTS

7-12. INSTRUMENT CLUSTER REMOVAL AND REPLACEMENT.

TOOLS: Flat-tip screwdriver
3/4-inch open end wrench
9/16-inch open end wrench
3/8-inch open end wrench (2)

SUPPLIES: Tags

PERSONNEL: One

EQUIPMENT CONDITION: Truck parked, engine off, handbrake set.

- a. Preliminary Procedure. Disconnect battery ground cable. Refer to para 7-58.
- b. Removal.

NOTE

Tag all connectors so they can be put back in the right place.

FRAME 1

- 1. Using screwdriver, turn mounting studs (1) 1/4turn to the left.
 - 2. Pull instrument cluster (2) about 2 inches away from the instrument panel (3).
- GO TO FRAME 2

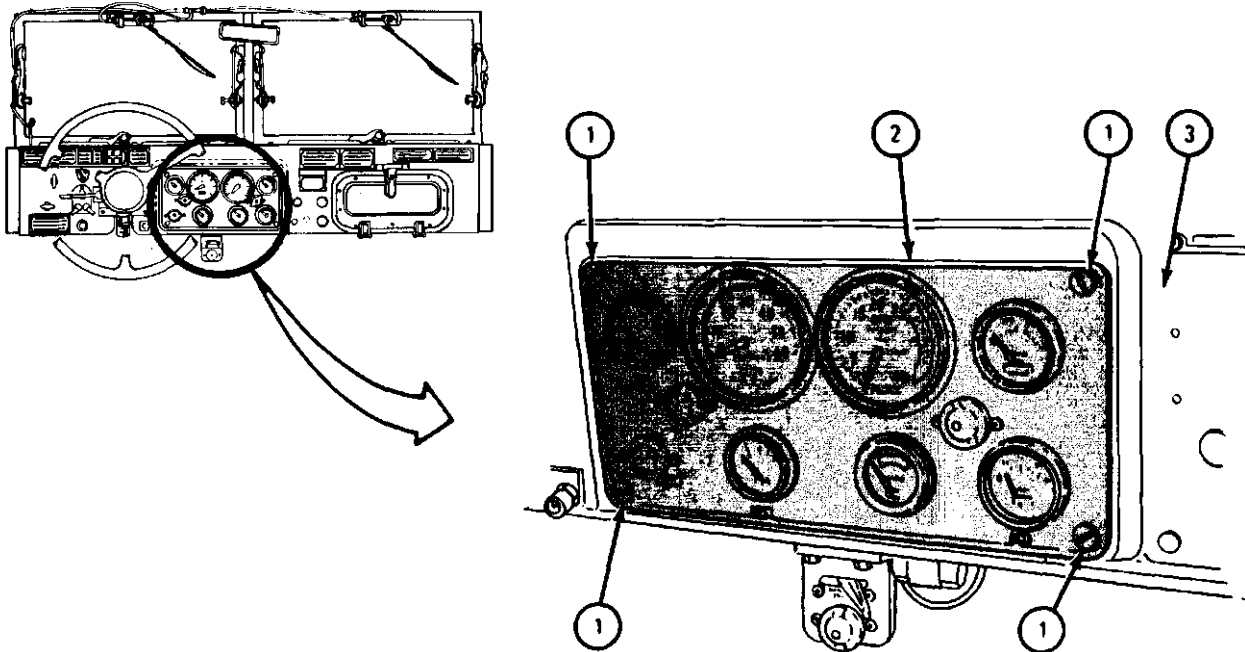

TA 047307

FRAME 2

NOTE

Tag each drive shaft assembly (1 and 2) so they can be put back in the right places.

1. Working from behind instrument cluster (3) and using 3/4-inch open end wrench, unscrew nut (4) and take off tachometer drive shaft (1).
2. Using 3/4-inch open end wrench, unscrew nut (5) and take off speedometer drive shaft (2). Pull down instrument cluster (3).

GO TO FRAME 3

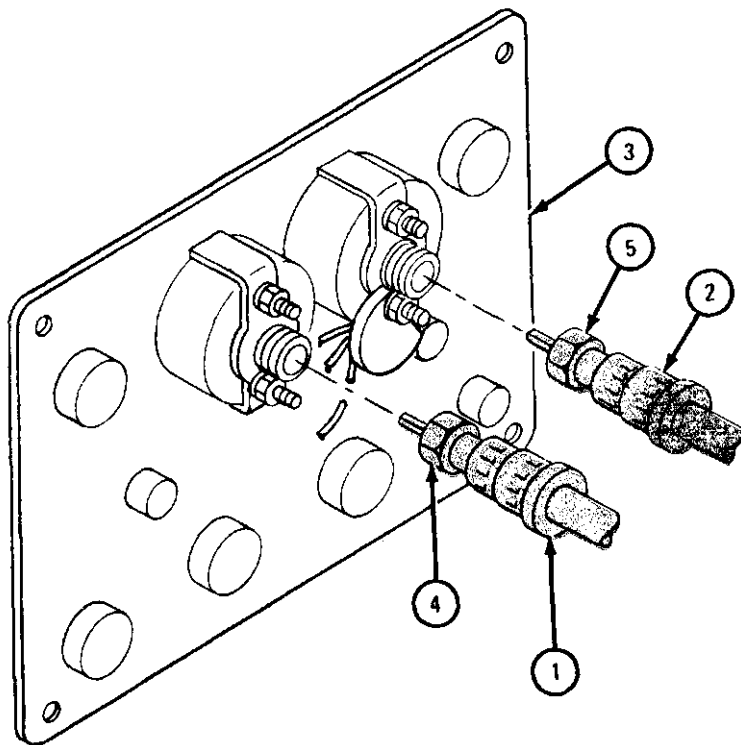

TA 049488

FRAME 3

1. Pull off two connectors (1) from temperature gage (2).
2. Pull off two connectors (3) from fuel gage (4).

GO TO FRAME 4

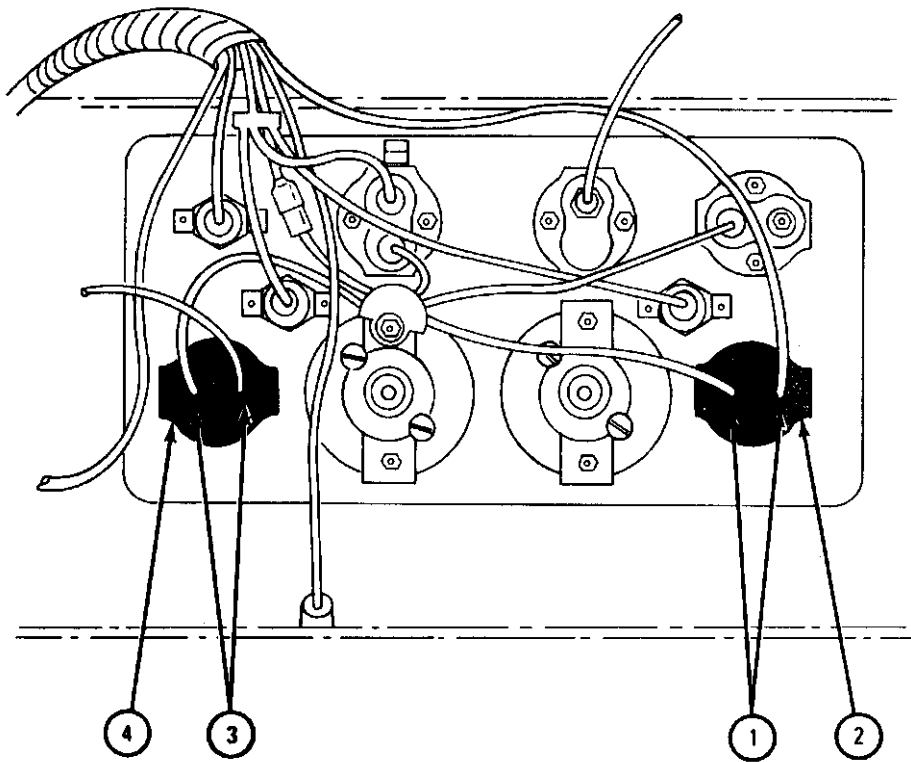

TA 047704

FRAME 4

1. Pull off two connectors (1) from panel lights (2).
2. Pull out instrument cluster connector (3) from circuit breaker connector (4).
3. Pull off connector (5) from high beam indicator (6).

GO TO FRAME 5

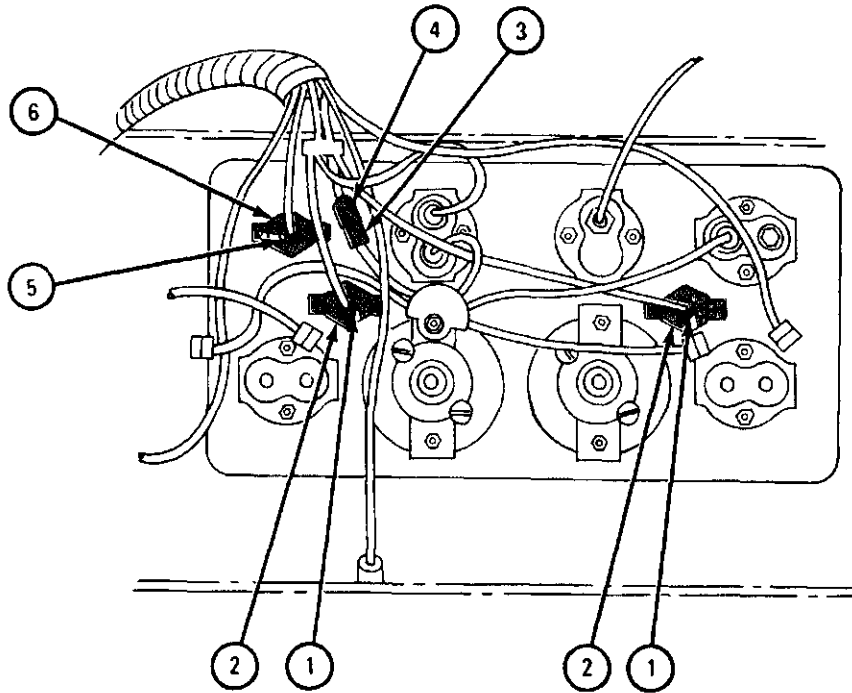

TA 047705

FRAME 5

1. Pull off connector (1) from battery-generator indicator (2).
2. Pull off two connectors (3) from oil pressure gage (4).
3. Using 9/16-inch wrench, unscrew nut (5) and take off hose (6) from air pressure gage (7).
4. Set instrument cluster (8) aside.
5. Using 3/8-inch wrenches, hold stud (9) under harness assembly (10) and unscrew and take off nut and lockwasher (11).

END OF TASK

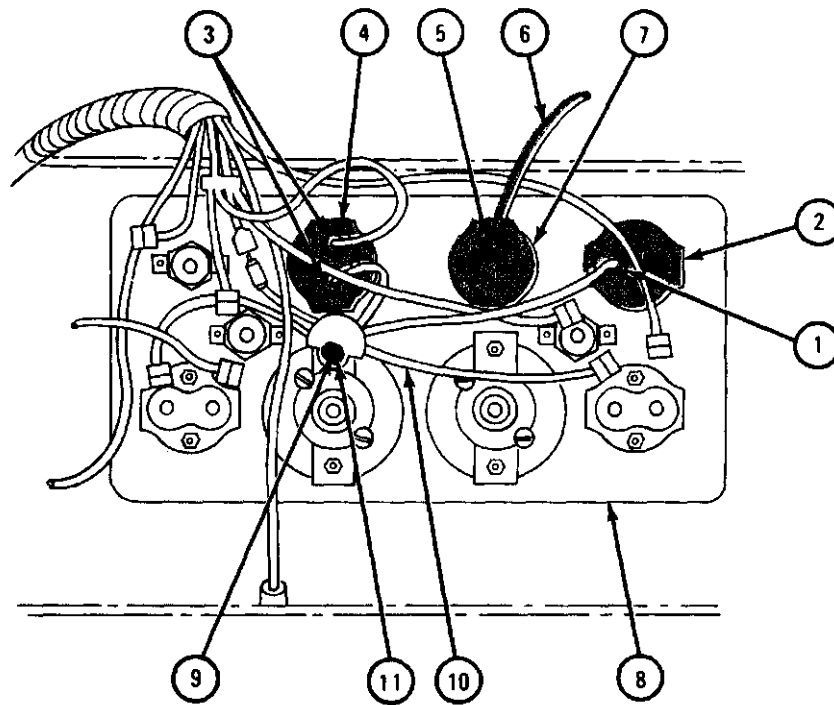

TA 047706

c. Replacement.

FRAME 1

1. Put harness assembly (1) on stud on speedometer (2). Using 3/8-inch wrench, screw on and tighten nut and lockwasher (3).
2. Push two connectors (4) on temperature gage (5) as tagged.
3. Push two connectors (6) on fuel gage (7) as tagged.
4. Take off tags.

GO TO FRAME 2

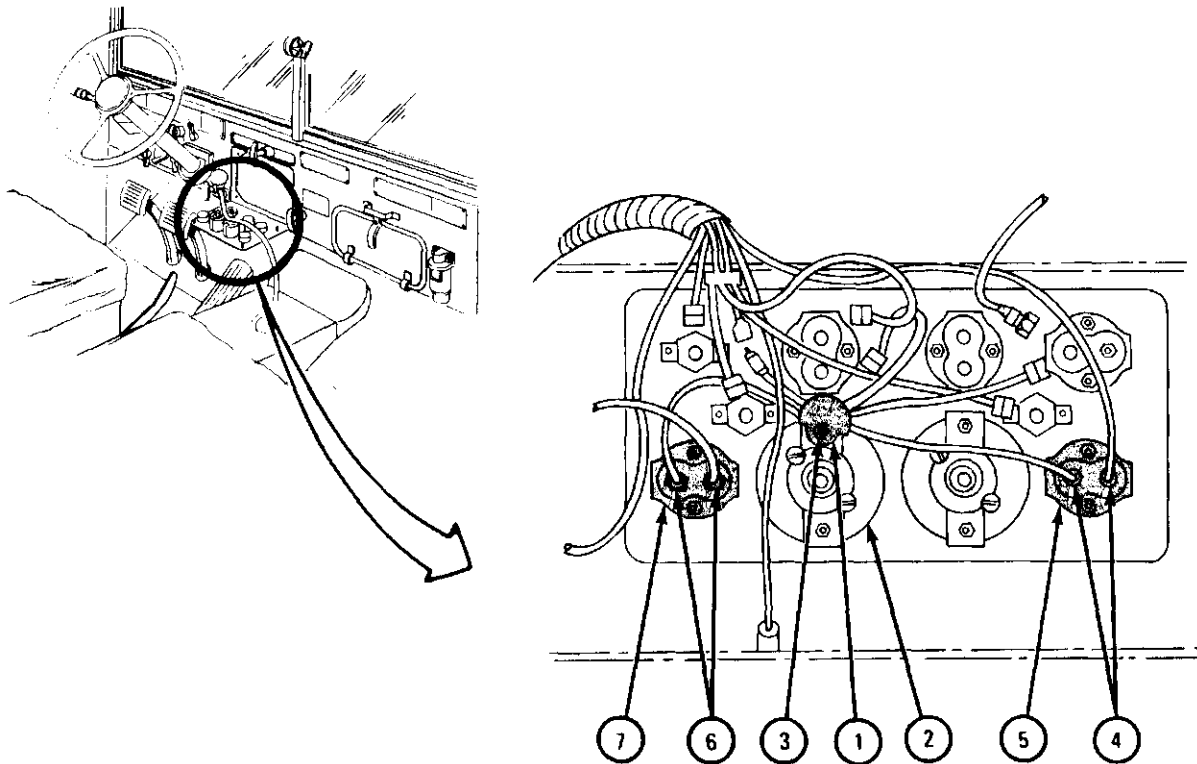

TA 047707

FRAME 2

1. Push connectors (1) on panel lights (2) as tagged.
2. Push connector (3) on high beam indicator (4) as tagged.
3. Join circuit breaker connector (5) to instrument cluster connector (6) as tagged. Push connector (6) into connector (5).
4. Take off tags.

GO TO FRAME 3

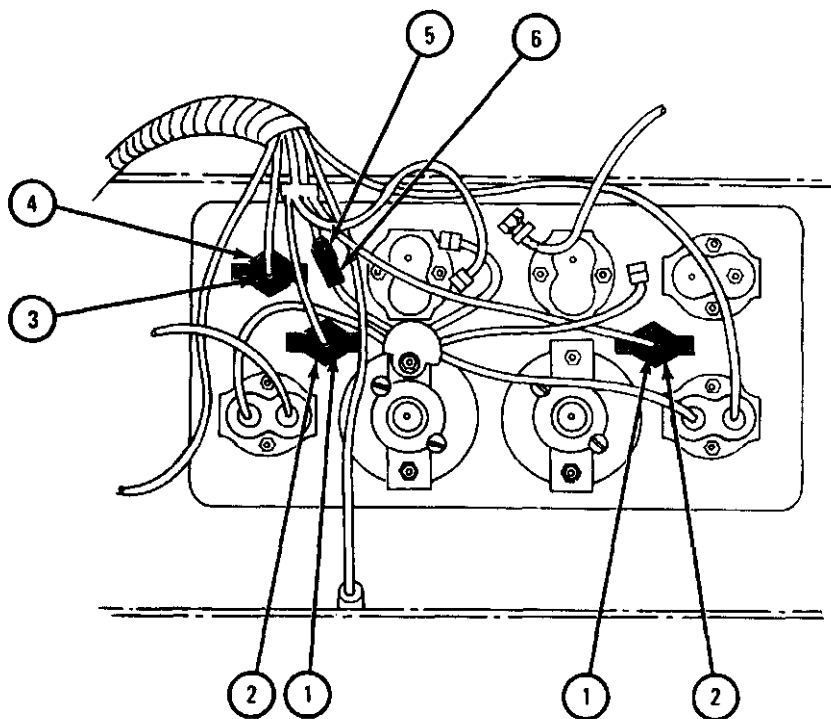

TA 047708

FRAME 3

1. Push connector (1) on battery-ground indicator (2) as tagged.
2. Push two connectors (3) on oil pressure gage (4) as tagged.
3. Join hose (5) to air pressure gage (6). Using 9/16-inch wrench, screw on and tighten nut (7).
4. Take off tags.

Go TO FRAME 4

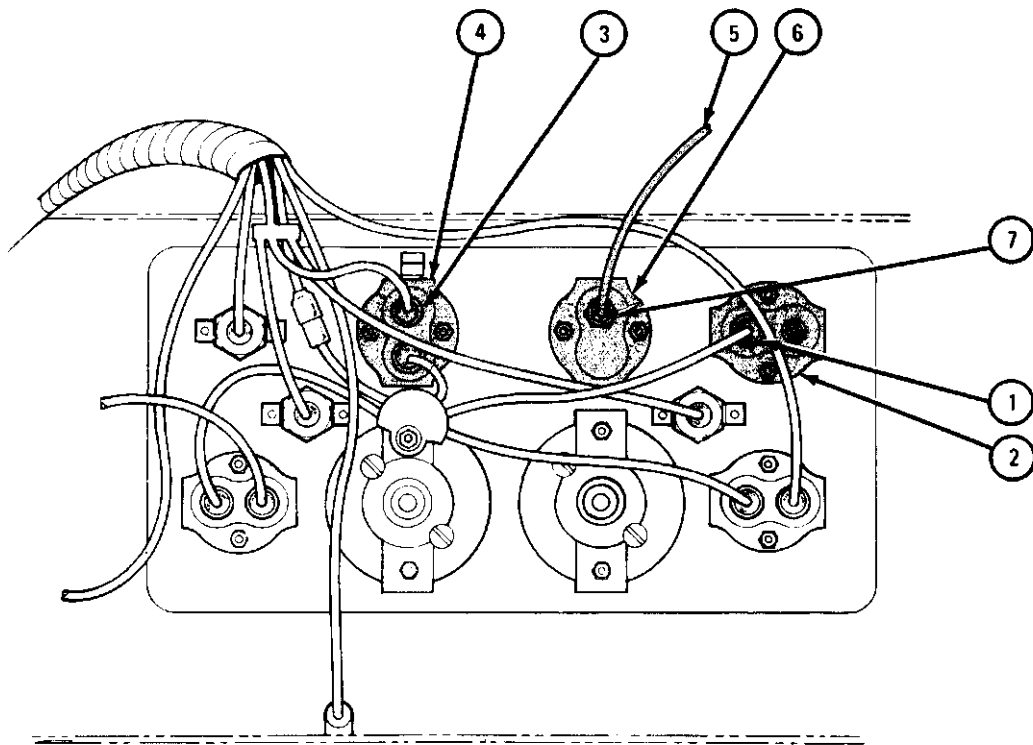

TA 047709

FRAME 4

1. Push instrument cluster (1) up to instrument panel (2) so two drive shaft assemblies (3) can be put on.
2. Working in between instrument cluster (1) and instrument panel (2), and using 3/4-inch open end wrench, screw on and tighten two drive shaft assemblies (3) as tagged.
4. Take off tags.

GO TO FRAME 5

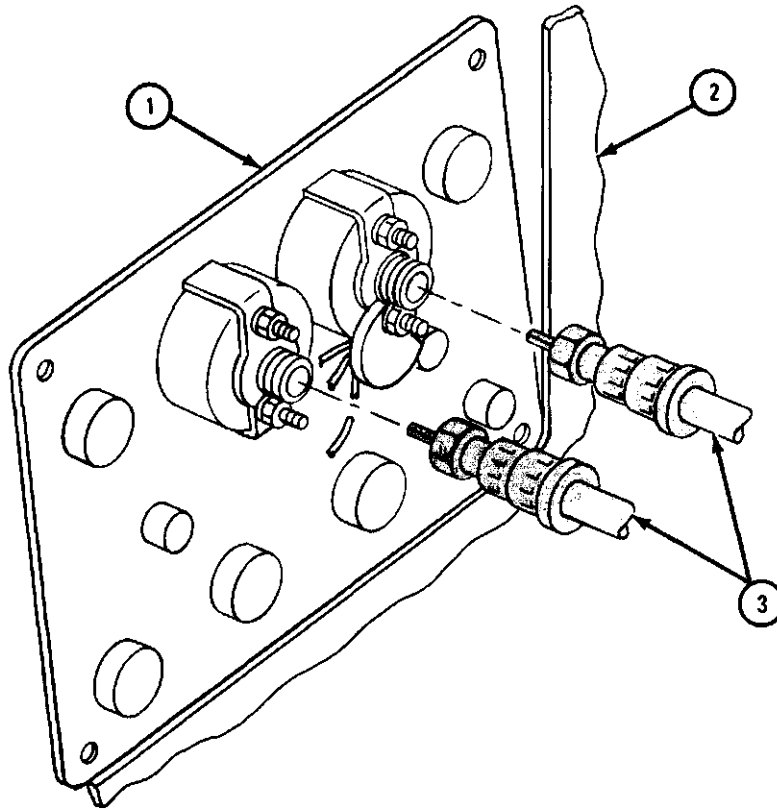

TA 101588

FRAME 5

1. Push instrument cluster (1) all the way up to instrument panel (2).
2. Using screwdriver, turn four mounting screws (3) 1/4 turn to right. Check that instrument cluster (1) is held in panel (2).

NOTE

Follow-on Maintenance Action Required:

Reconnect battery ground cable. Refer to para 7-58.

END OF TASK

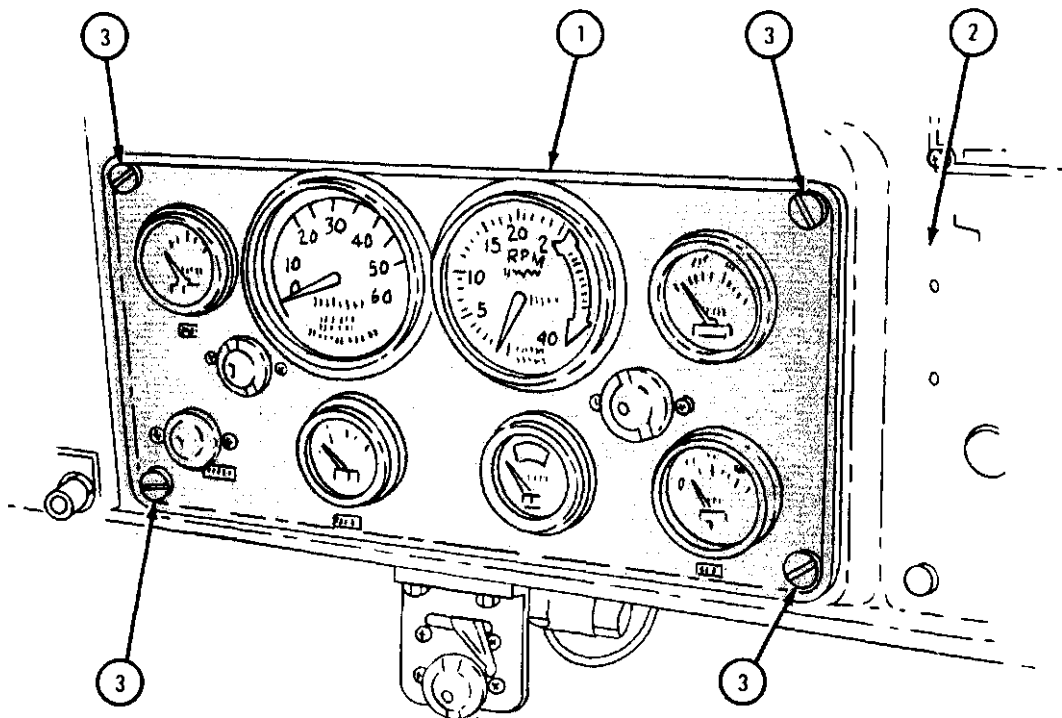

TA 047320

7-13. INSTRUMENT CLUSTER COMPONENTS (EXCEPT SPEEDOMETER AND TACHOMETER) REMOVAL AND REPLACEMENT

NOTE

Procedure for removal and replacement for each of the instruments on instrument cluster is the same.

TOOLS: Flat-tip screwdriver
3/8-inch open end wrench

SUPPLIES: None

PERSONNEL: One

EQUIPMENT CONDITION: Truck parked, engine off, handbrake set.

a. Preliminary Procedures.

- (1) Disconnect battery ground cable. Refer to para 7-58.
- (2) Remove instrument cluster. Refer to para 7-12.

b. Removal.

FRAME 1

1. Using 3/8-inch wrench, unscrew and take off two nuts (1) from two mounting studs (2).
 2. Take off two lockwashers (3) and bracket (4).
 3. Pull temperature gage (5) out from front of instrument cluster (6).
- GO TO FRAME 2

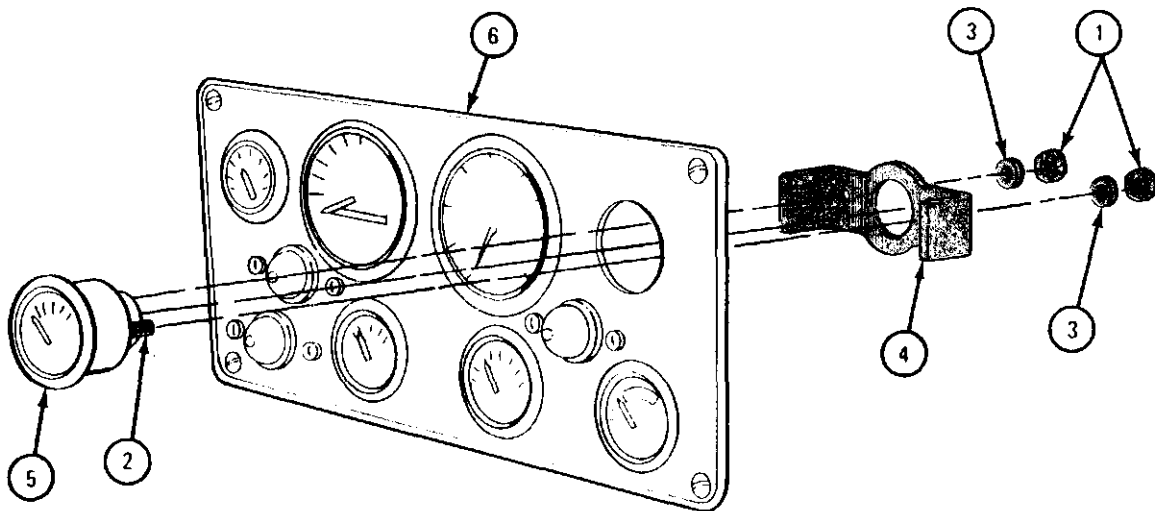

TA 047117

FRAME 2

1. Turn lens (1) to the left and take it off.
2. Press in and turn lamp (2) to the left and take out lamp from front of cluster panel (3).
3. Using screwdriver, unscrew and take out two screws and lockwashers (4).
4. Take headlight beam indicator assembly (5) out of cluster panel (3) from back of panel.

NOTE

Procedures for taking out two instrument cluster light assemblies (6) are the same.

END OF TASK

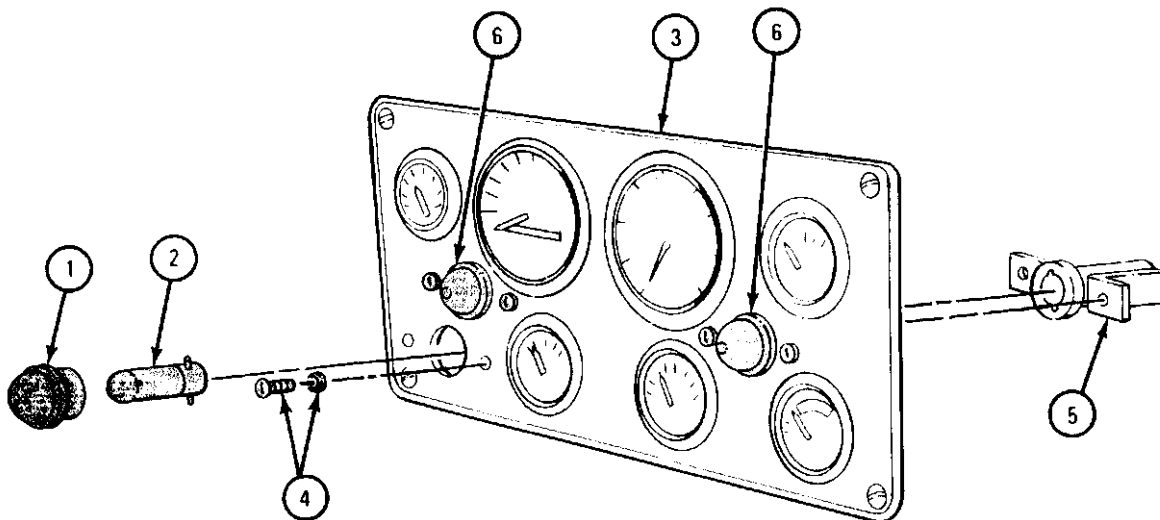

TA 047118

c. Replacement.

FRAME 1

1. Put headlight beam indicator assembly (1) against back of cluster panel (2) and line up mounting holes.
2. Using screwdriver, screw in two screws and lockwashers (3).
3. put lamp (4) in **headlight beam indicator assembly (1) from front of cluster panel (2)**. Press in and turn lamp right.
4. Put lens (5) on headlight beam indicator assembly (1) from front of cluster panel (2). Turn lens right to tighten.

NOTE

Procedures for putting in two instrument cluster light assemblies (6) are the same.

GO TO FRAME 2

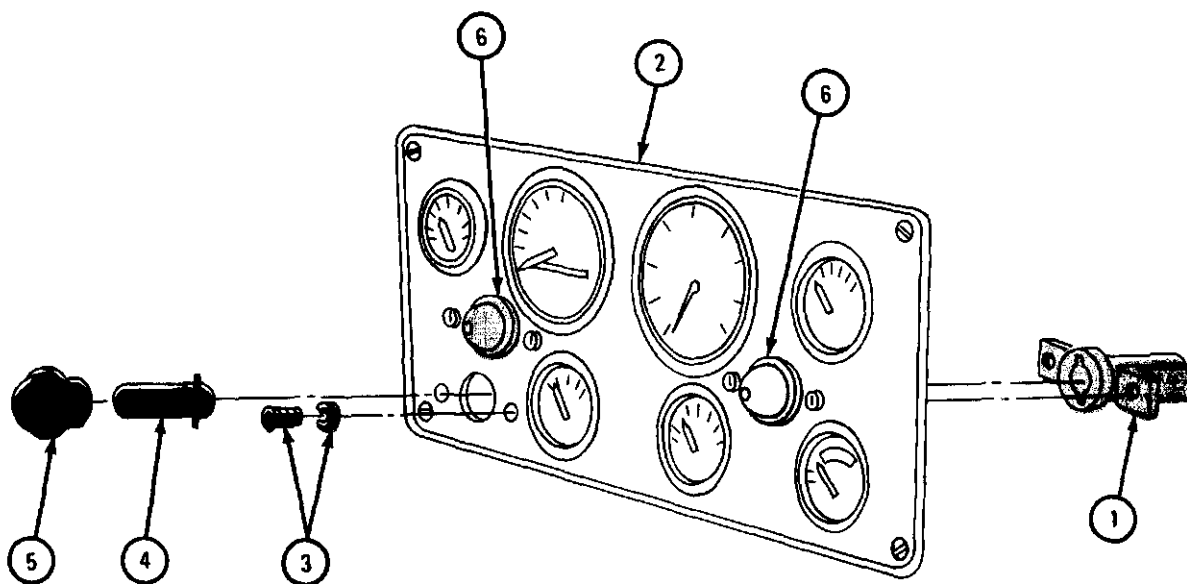

TA 047119

FRAME 2

NOTE

Make sure replacement temperature gage (1) is matched to sending unit.

1. Put temperature gage (1) through hole in cluster panel (2) from front of panel.
2. Put mounting bracket (3) on two studs (4) from back of cluster panel (2).
3. Using 3/8-inch wrench, screw on and tighten two nuts and lockwashers (5) on studs (4).

NOTE

Procedure for replacing each of the seven instruments on instrument cluster is the same.

NOTE

Follow-on Maintenance Action Required:

1. Reconnect battery ground cable. Refer to para 7-58.
2. Replace instrument cluster. Refer to para 7-12.

END OF TASK

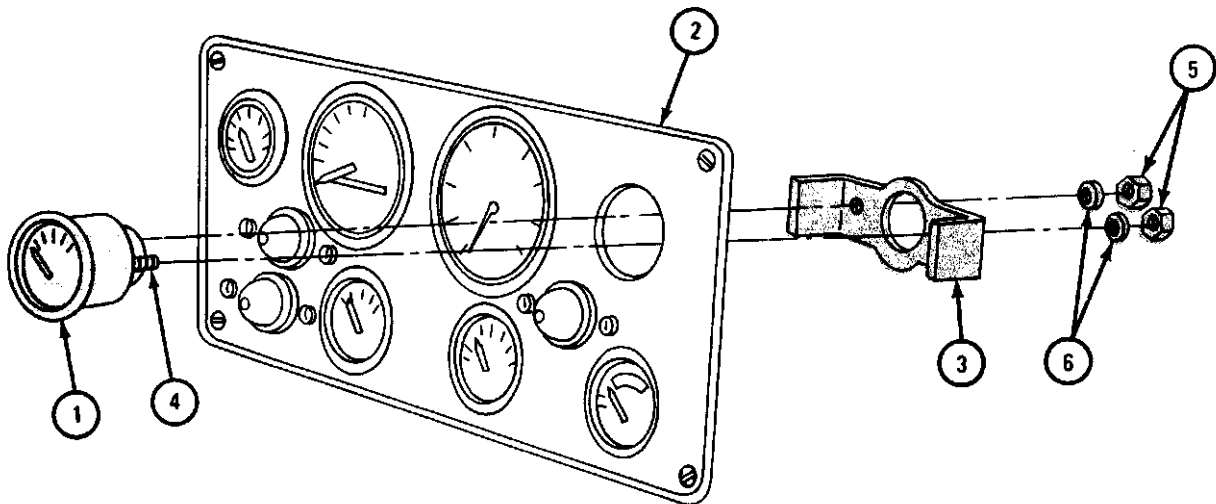

TA 047120

7-14. LIGHT SWITCH REMOVAL AND REPLACEMENT.

TOOLS: Spanner wrench
Cross-tip screwdriver (Phillips type)
Flat-tip screwdriver

SUPPLIES: None

PERSONNEL: One

EQUIPMENT CONDITION: Truck parked, engine off, handbrake set.

- a. Preliminary Procedure. Disconnect battery ground cable. Refer to para 7-58.
- b. Removal.

FRAME 1

1. Using flat-tip screwdriver, unscrew and take out three screws (1). Take off three handles (2).
2. Using phillips screwdriver, unscrew and take out four screws (3).
3. Push light switch (4) into instrument panel (5).
4. Take out light switch (4) from back of instrument panel (5) and let it hang below instrument panel.

GO TO FRAME 2

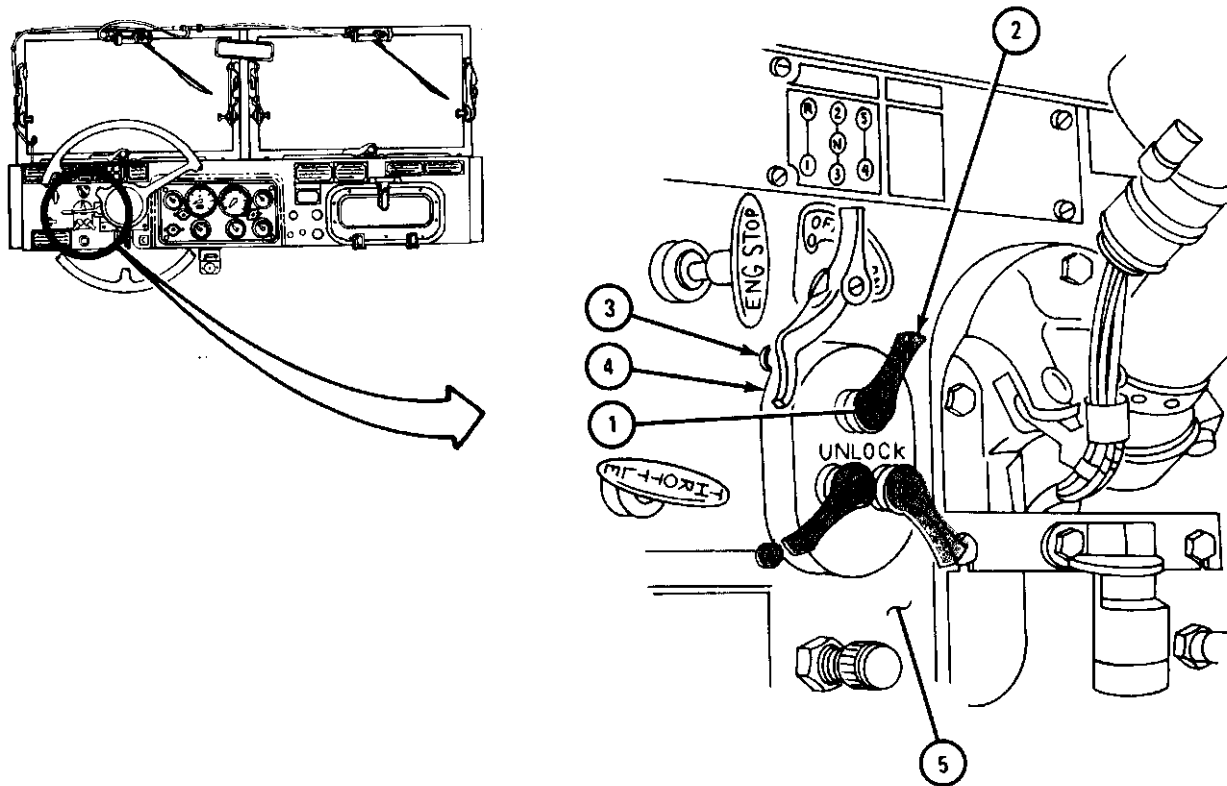

TA 080836

FRAME 2

1. Using wrench, unscrew nut (1).
2. Pull harness plug (2) from receptacle (3).

END OF TASK

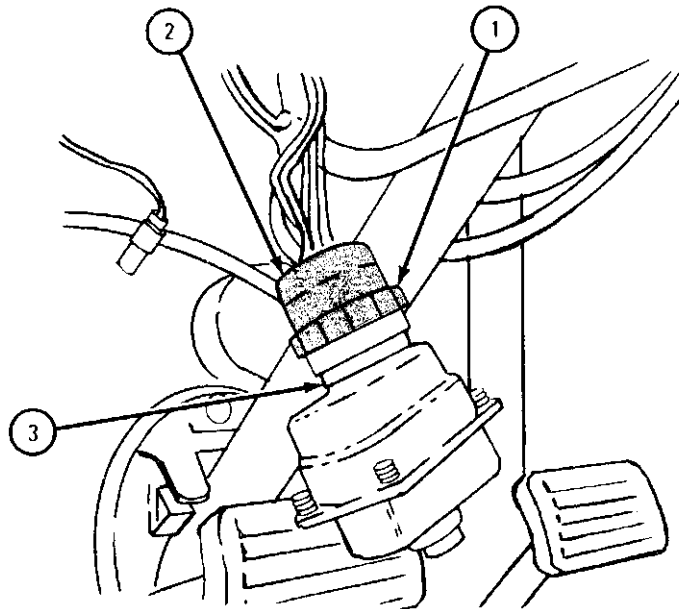

TA 080835

c. Replacement.

FRAME 1

1. Push harness plug (1) into receptacle (2).
 2. Using wrench, screw on and tighten nut (3).
- GO TO FRAME 2

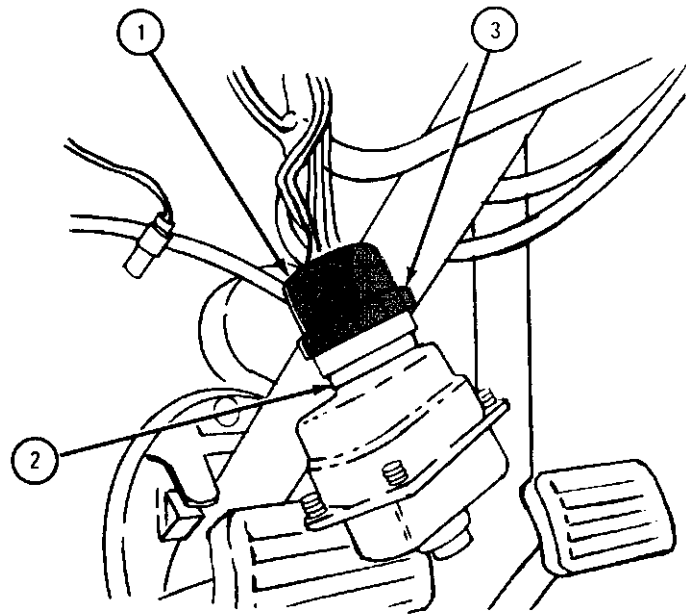
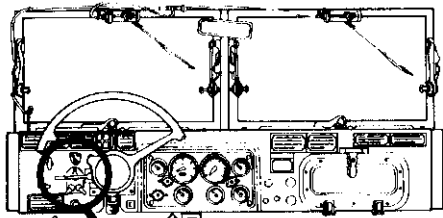

TA 080838

FRAME 2

1. Place light switch (1) into opening in instrument panel (2), from back of panel.
2. Aline holes in light switch (1) with holes in instrument panel (2).
3. Using phillips screwdriver, screw in and tighten four screws (3).
4. Put three handles (4) in place.
5. Using flat-tip screwdriver, screw in and tighten three screws (5).

NOTE

Follow-on Maintenance Action Required:

Reconnect battery ground cable. Refer to para 7-58.

END OF TASK

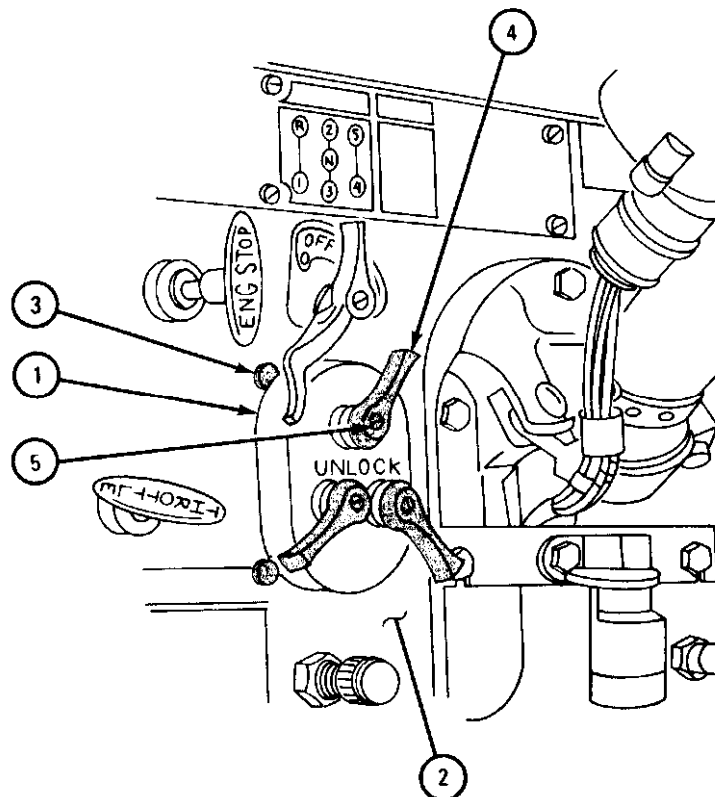

TA 080837

7-15. ACCESSORY SWITCH REMOVAL AND REPLACEMENT.

TOOLS: Flat-tip screwdriver
5/8-inch wrench

SUPPLIES: Tags

PERSONNEL: One

EQUIPMENT CONDITION: Truck parked, engine off, handbrake set.

- a. Preliminary Procedure. Disconnect battery ground cable. Refer to para 7-58.
- b. Removal.

FRAME 1

- 1. Using screwdriver, unscrew and takeout screw (1).
- 2. Takeoff handle (2).
- 3. Using 5/8-inch wrench, unscrew and take off nut and lockwasher (3).
- 4* Take off switch plate (4).

GO TO FRAME 2

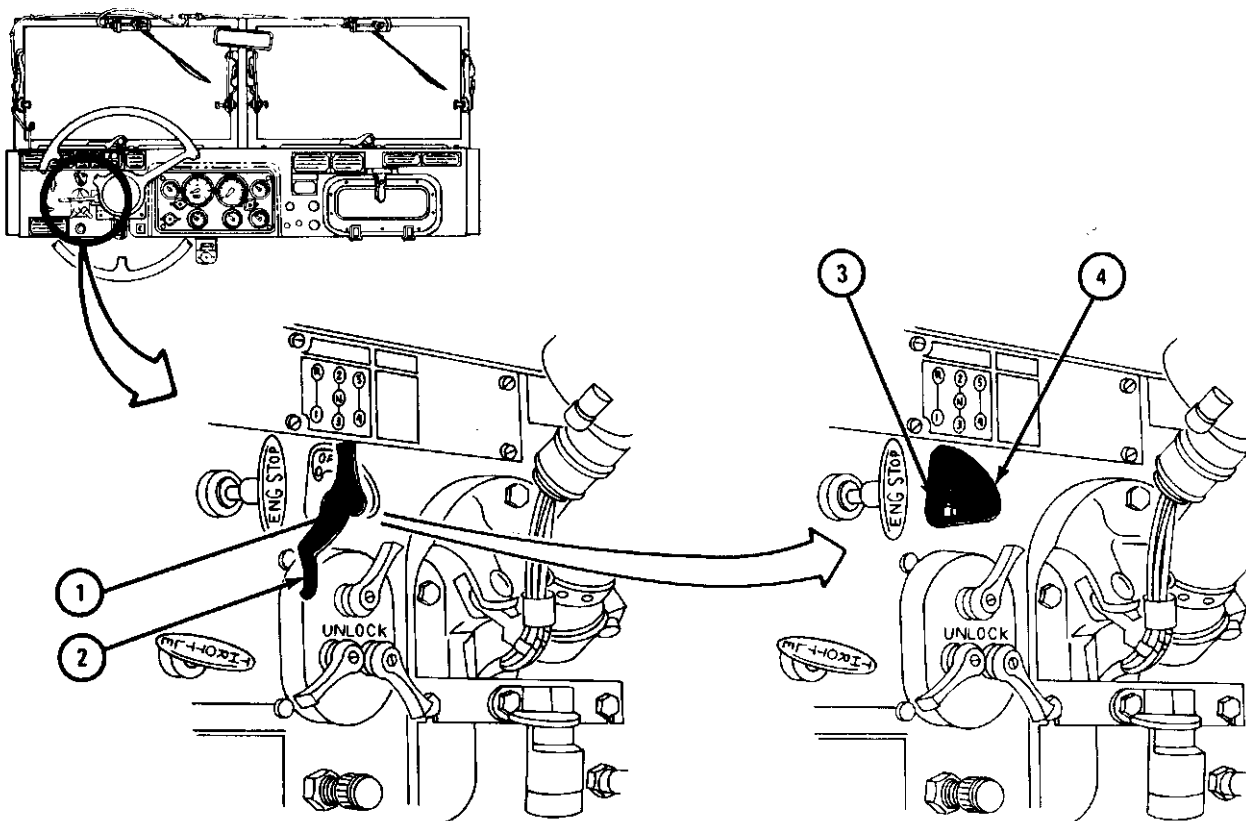

TA 080839

FRAME 2

NOTE

Tag all wires before taking them off so they will be put back in same place.

1. Working behind instrument panel (1), pull switch (2) out and down below edge of instrument panel as shown.
2. Pull four connectors (3) off switch (2).

END OF TASK

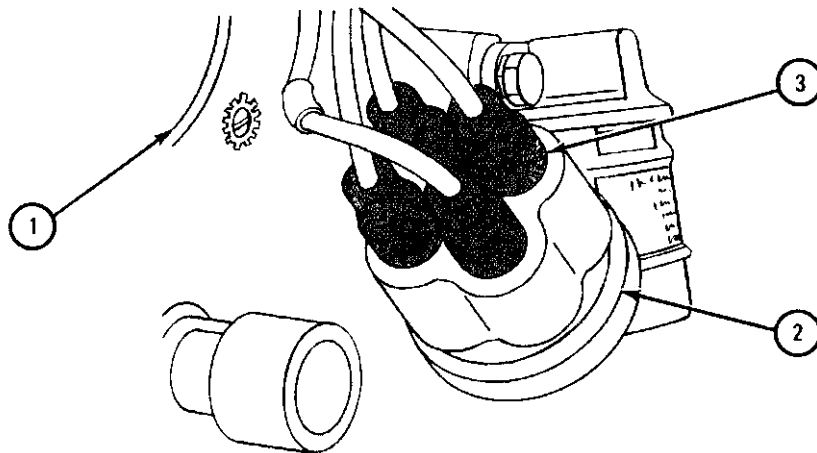

TA 080840

c. Replacement.

FRAME 1

1. Working under instrument panel (1), plug four connectors (2) into switch (3) as tagged. Take off tags.
2. Put switch (3) through hole in instrument panel (1) from behind instrument panel.

GO TO FRAME 2

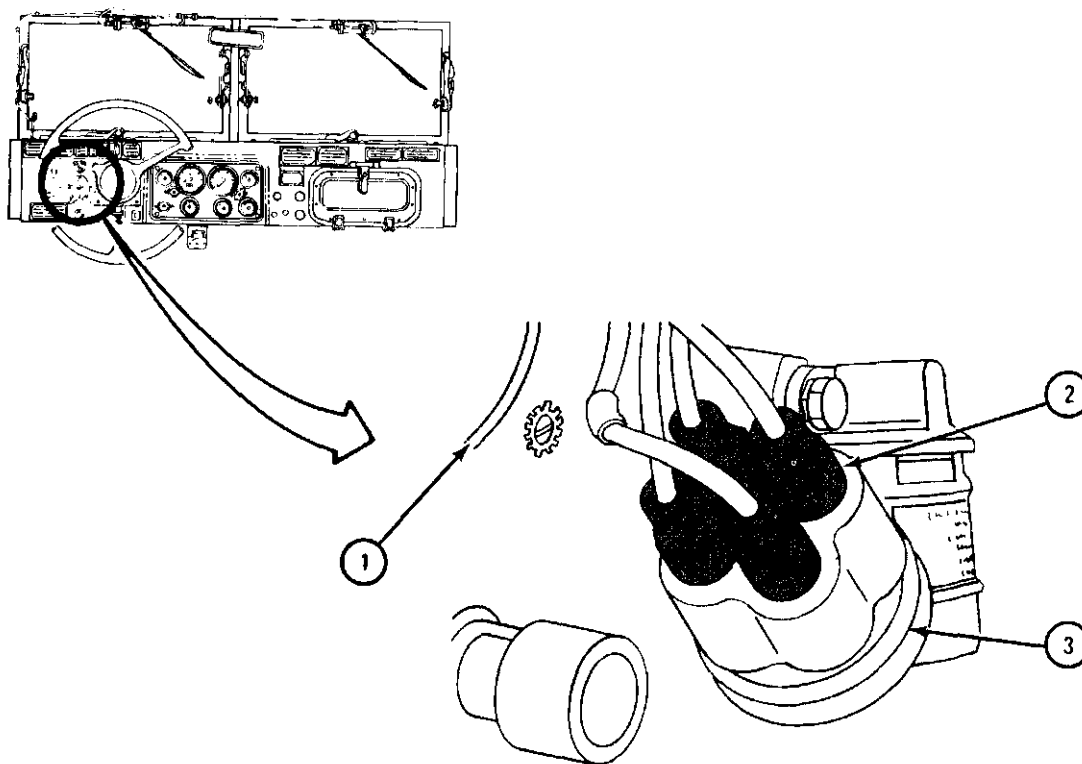

TA 080841

FRAME 2

1. Put switch plate (1) in place.
2. Using 5/8-inch wrench, screw on and tighten nut and lockwasher (2).
3. Put handle (3) in place.
4. Using screwdriver, screw in and tighten screw (4).

NOTE

Follow-on Maintenance Action Required:

Reconnect battery ground cable. Refer to para 7-58.

END OF TASK

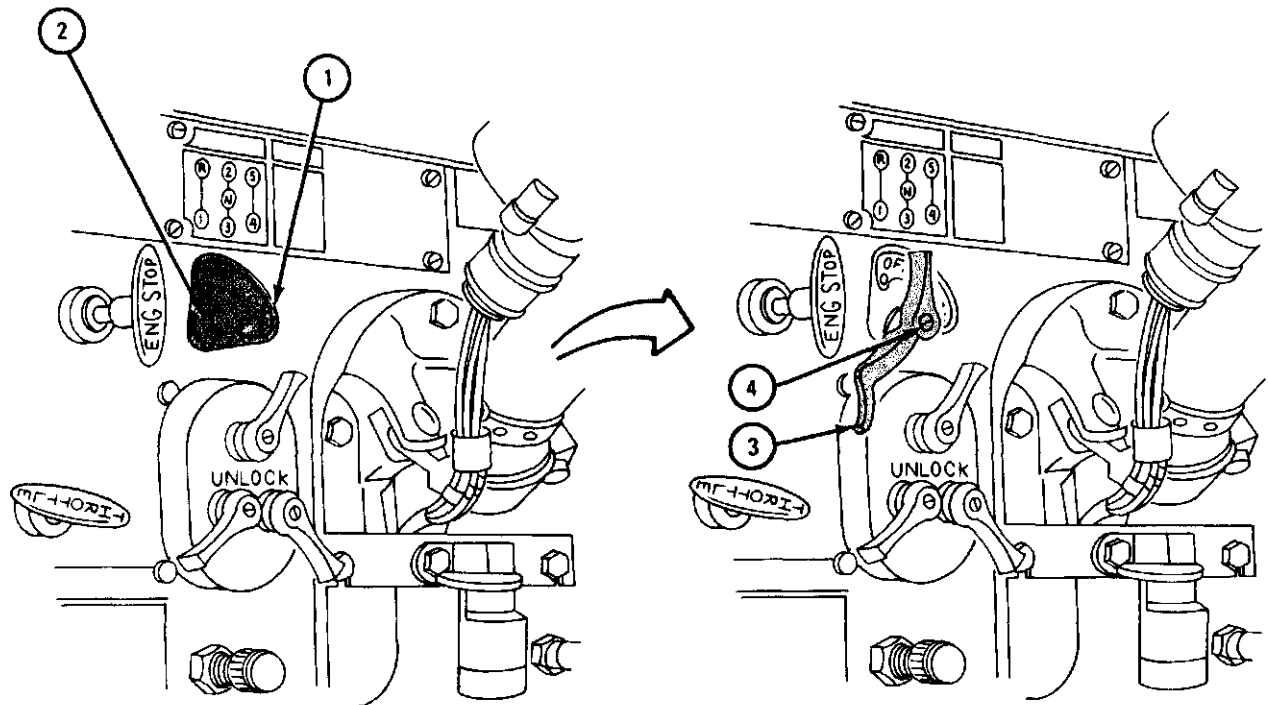

TA 080842

7-16. CIRCUIT BREAKER REMOVAL AND REPLACEMENT.

TOOLS: Cross-tip screwdriver (Phillips type)

SUPPLIES: None

PERSONNEL: One

EQUIPMENT CONDITION: Truck parked, engine off, handbrake set.

a. Preliminary Procedures.

(1) Open hood and left side panel. Refer to TM 9-2320-209-10.

(2) Disconnect battery ground cable. Refer to para 7-58.

b. Removal.

FRAME 1

1. Take off connectors (1 and 2).
2. Using phillips screwdriver, unscrew two screws (3). Take out screws and take circuit breaker (4) off firewall (5).

NOTE

Trucks with auxiliary power outlets have an additional 15-ampere circuit breaker. This circuit breaker is located next to circuit breaker (4). Removal procedures are same for both breakers.

END OF TASK

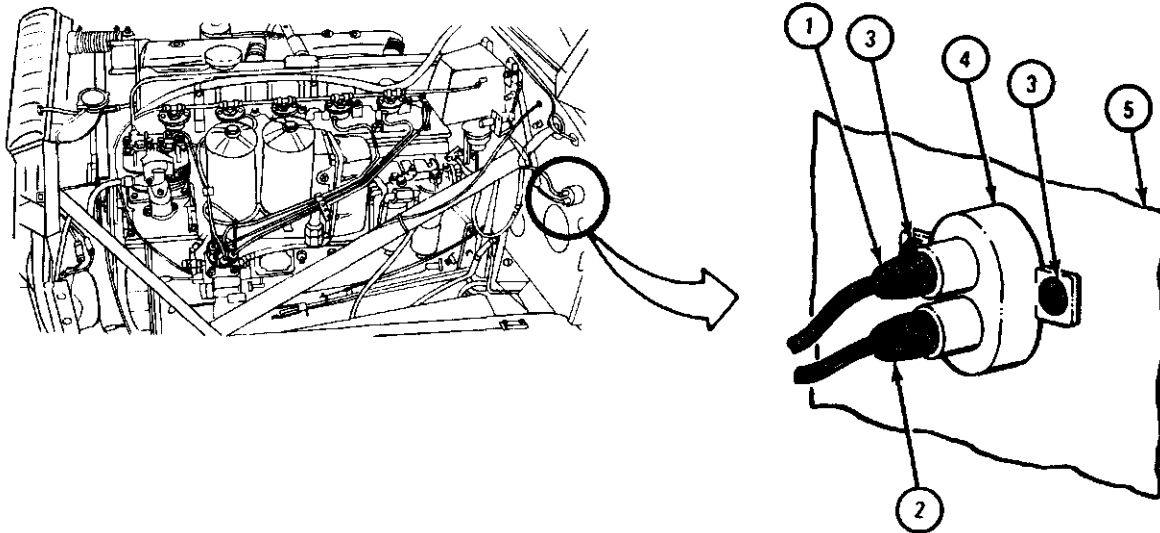

TA 047115

c. Replacement.**FRAME 1**

1. Put circuit breaker (1) on firewall (2) as shown and line up two mounting holes,
2. Put two screws (3) in mounting holes and tighten, using phillips screwdriver.
3. Plug connectors (4 and 5) into circuit breaker (1) as shown.

NOTE

Trucks with auxiliary power outlets have an additional 15-ampere circuit breaker. This circuit breaker is located next to circuit breaker (1). Replacement procedures are same for both breakers.

NOTE**Follow-on Maintenance Action Required:**

1. Reconnect battery ground cable. Refer to para 7-58.
2. Close hood and left side panel. Refer to TM 9-2320-209-10.

END OF TASK

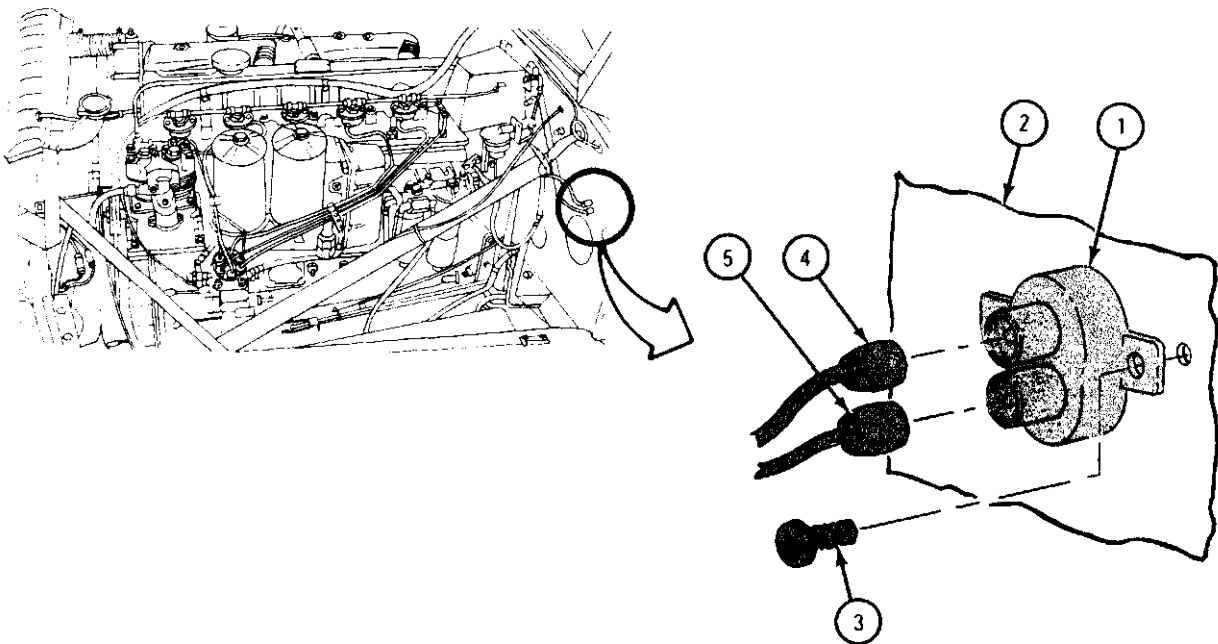

TA 047116

Section V. LIGHTING SYSTEM

7-17. FRONT SERVICE HEADLIGHT ASSEMBLY REMOVAL AND REPLACEMENT.

TOOLS: 7/16-inch open end wrench

SUPPLIES: Tags

PERSONNEL: One

EQUIPMENT CONDITION: Truck parked, engine off, handbrake set, light switch in OFF position.

a. Preliminary Procedure. Open hood and side panel. Refer to TM 9-2320-209-20-10.

b. Removal.

FRAME 1

NOTE

Tag plugs (1) so they will be put back in same place.

1. Unplug three electrical plugs (1) from rear of headlight assembly (2).
2. Using 7/16-inch wrench, unscrew and take off three nuts (3) from three shock mount studs (4). Take off washers (5).
3. Take out headlight assembly (2) from front of truck.

END OF TASK

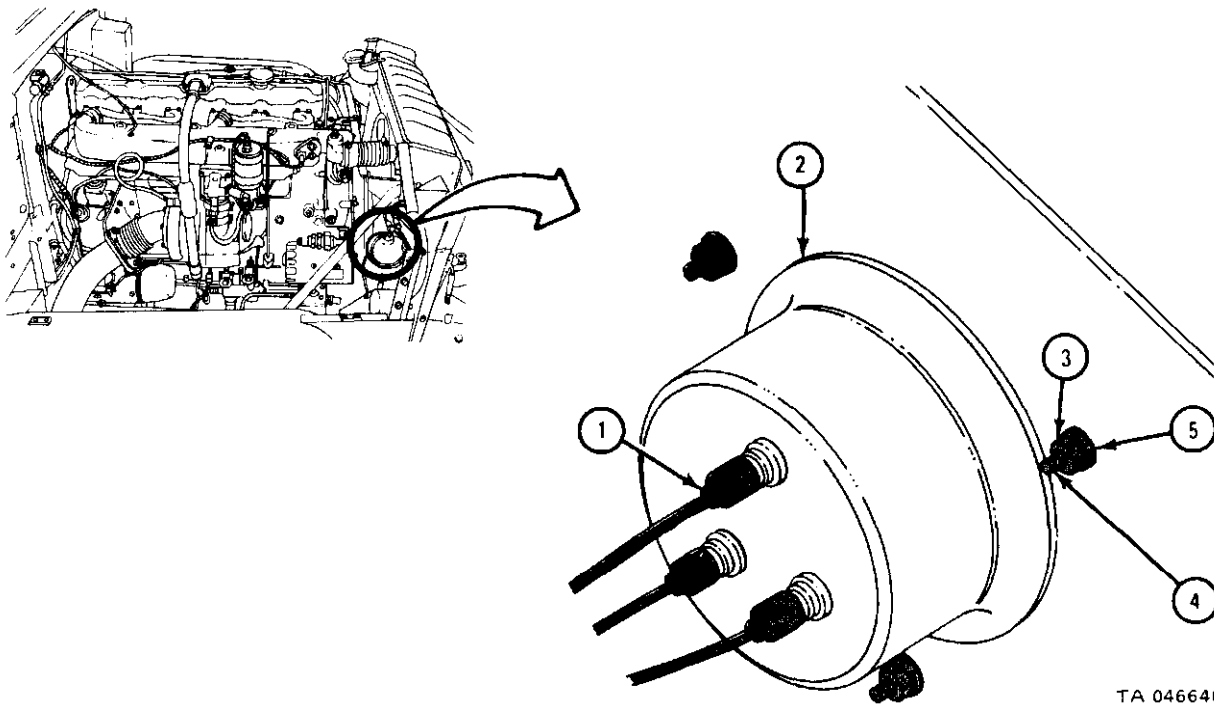

c. Replacement.

FRAME 1

1. Put headlight assembly (1) in truck from front with three shock mount studs (2) through holes.
2. Using 7/16-inch wrench, screw on and tighten three nuts (3) and three washers (4).
3. Plug in three electrical plugs (5) to three connectors (6) as tagged. Take off tags.

NOTE

Follow-on Maintenance Action Required:

Close hood and side panel. Refer to TM 9-2320-209-10.

END OF TASK

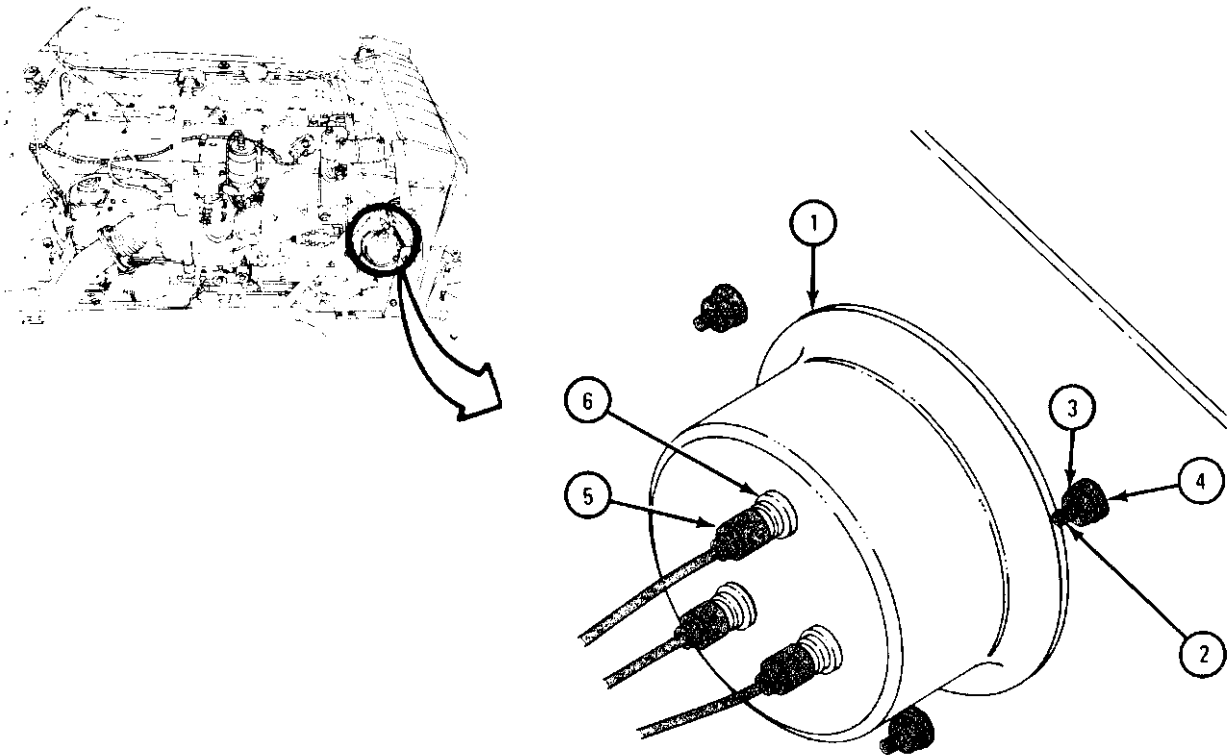

TA 046641

7-18. FRONT SERVICE HEADLIGHT ASSEMBLY REPAIR.

TOOLS: Flat-tip screwdriver 7/16-inch box wrench
6-inch long nose pliers 3/8-inch drive extension, 12 inches long
7/16-inch socket wrench 3/8-inch drive ratchet
3/8-inch drive

SUPPLIES: Solvent, dry cleaning, type II (SD-2), Fed. Spec P-D-680

PERSONNEL: One

EQUIPMENT CONDITION: Truck parked, engine off, handbrake set, light switch in OFF position.

a. Preliminary Procedures.

(1) Remove front service headlight assembly. Refer to para 7-17.

(2) Remove front service headlight sealed beam. Refer to para 7-20.

b. Disassembly.

FRAME 1

1. Using long nose pliers, unhook spring (1) from ring assembly (2) and headlamp housing (3).
2. Pull ring assembly (2) out and away from two adjusting screws (4).
3. Using screwdriver, unscrew and take out two adjusting screws (4).

GO TO FRAME 2

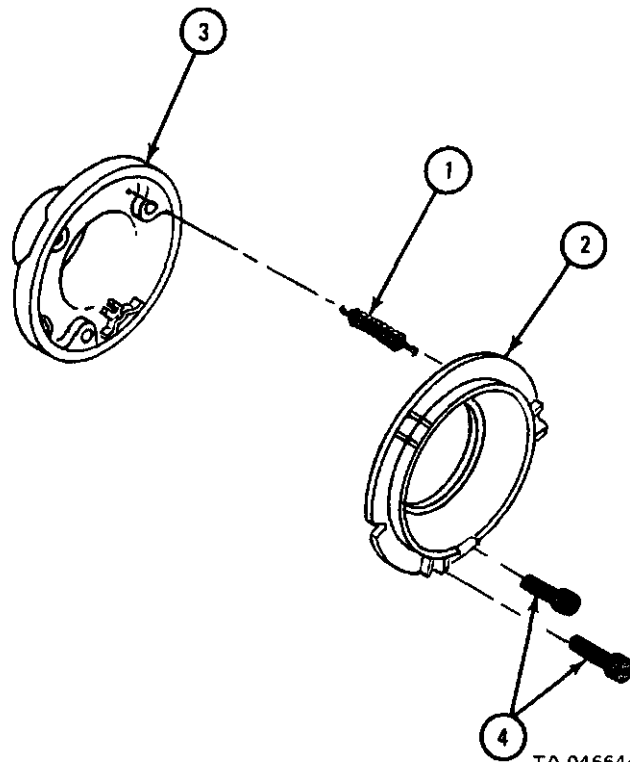

TA 046644

FRAME 2

1. Using 7/16-inch socket wrench with extension, unscrew and take off three nuts (1), three lockwashers (2), and three flat washers (3). Take off three shock mount studs (4).
2. Take off two adjusting screw nuts (5).
3. Push three electrical connector plugs (6) and three rubber grommets (7) out of headlight bracket (8).

END OF TASK

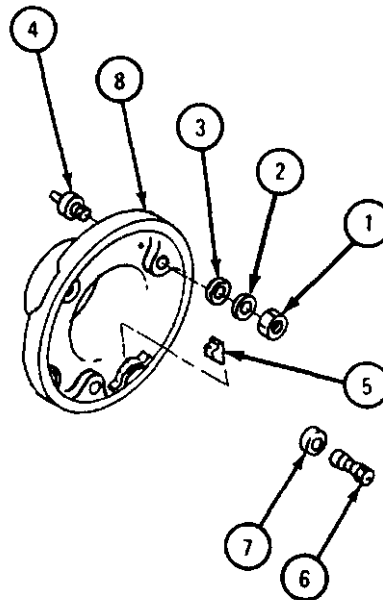

TA 085567

c. Cleaning, Inspection, and Repair.

FRAME 1

WARNING

Dry cleaning solvent is flammable. Do not use near an open flame. Keep a fire extinguisher nearby when solvent is used. Use only in well-ventilated places. Failure to do this may result in injury to personnel and damage to equipment.

1. Using solvent, clean all parts.
2. Check light door (1), ring assembly (2), and headlight housing (3) for dents, cracks or other damage. Check threads in headlight housing for damage.
3. Check sealed beam unit (4) for cracks, burned-out filaments or other damage.
4. Check wires and connectors (5) for damage. Check that wires are not broken and that insulation is not cut or cracked.
5. Check connector plugs (6), grommets (7), adjusting screw nuts (8), and shock mounts (9) for damage.
6. Check all screws for damaged threads.
7. Throw away damaged parts and get new ones in their place.

END OF TASK

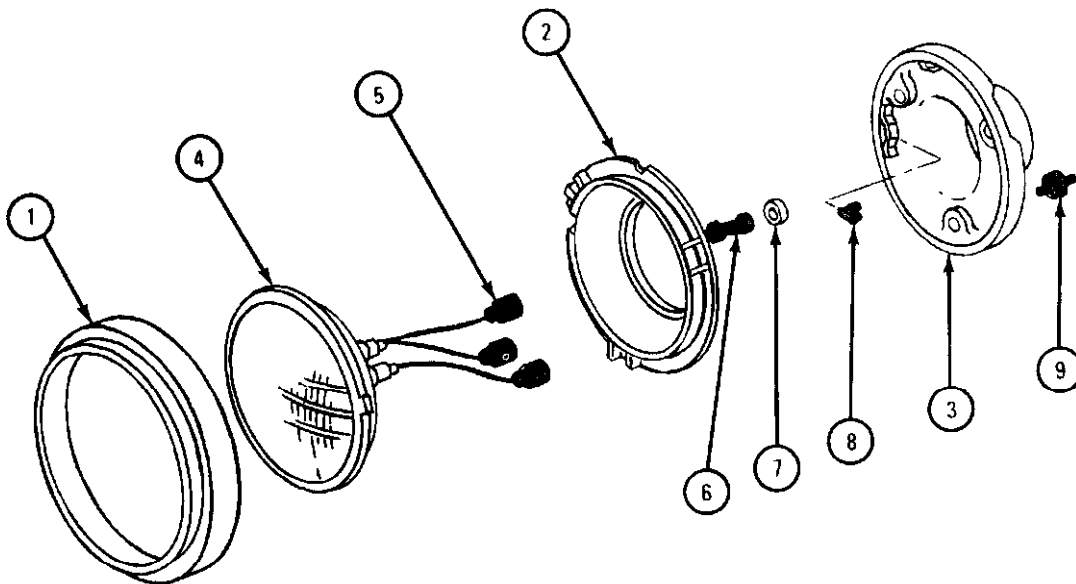

TA 085568

d. Assembly.

FRAME 1

1. Start three electrical connectors (1) and three rubber grommets (2) in headlamp housing (3) with tapered end of rubber grommets toward headlamp housing. Using screwdriver, seat rubber grommets.
2. Put on two adjusting screw nuts (4).
3. Using 7/16-inch socket wrench with extension, screw on and tighten three nuts (5), three lockwashers (6), and three flat washers (7) to three shock mount studs (8).

GO TO FRAME 2

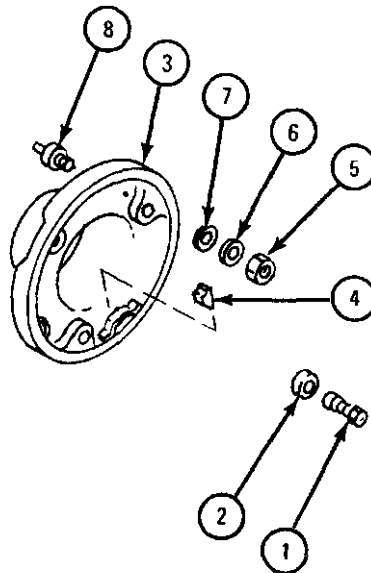

TA 046646

FRAME 2

1. Using screwdriver, screw two adjusting screws (1) halfway into adjusting screw nuts (2).
2. Hook one end of spring (3) into hole in headlamp housing (4).
3. Put two grooves on ring assembly (5) into grooves on two adjusting screws (1) and push ring assembly into headlamp housing (4).
4. Using long nose pliers, hook free end of spring (3) into hole in ring assembly (5).

NOTE

Follow-on Maintenance Action Required:

1. Replace front service headlight sealed beam. Refer to para 7-20.
2. Replace front service headlight assembly. Refer to para 7-17.
3. Do front service headlight assembly adjustment. Refer to para 7-19.

END OF TASK

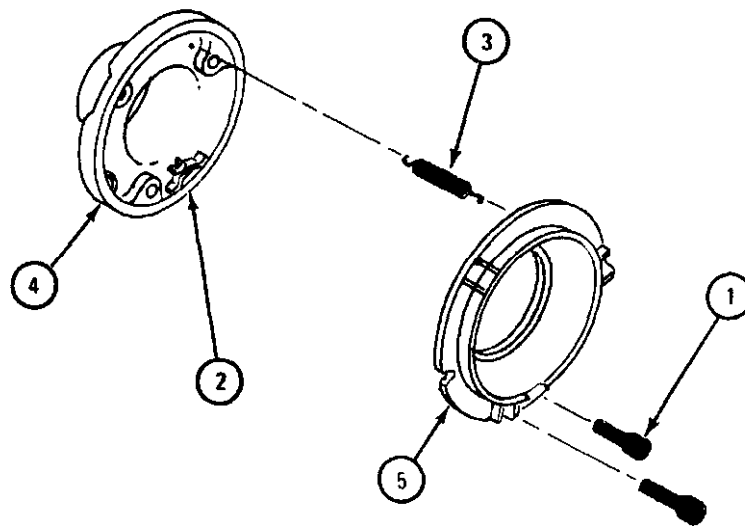

TA 046647

7-19. FRONT SERVICE HEADLIGHT ASSEMBLY ADJUSTMENT.

TOOLS: Flat-tip screwdriver
50-foot tape measure
Carpenter's square

SUPPLIES: Chalk, SS-C-266F
String

PERSONNEL: Three

EQUIPMENT CONDITION: Truck parked, engine off, handbrake set.

FRAME 1

1. Using tape measure and chalk, draw line (1) 25 feet from and parallel to vertical wall (2).
2. Start unloaded truck. Refer to TM 9-2320-209-10. Move truck so that head lights (3) are parallel with and directly above line (1). The center line of truck (4) will be at right angle (90°) to wall (2) as shown.
3. Stop engine and set handbrake. Refer to TM 9-2320-209-10.

GO TO FRAME 2

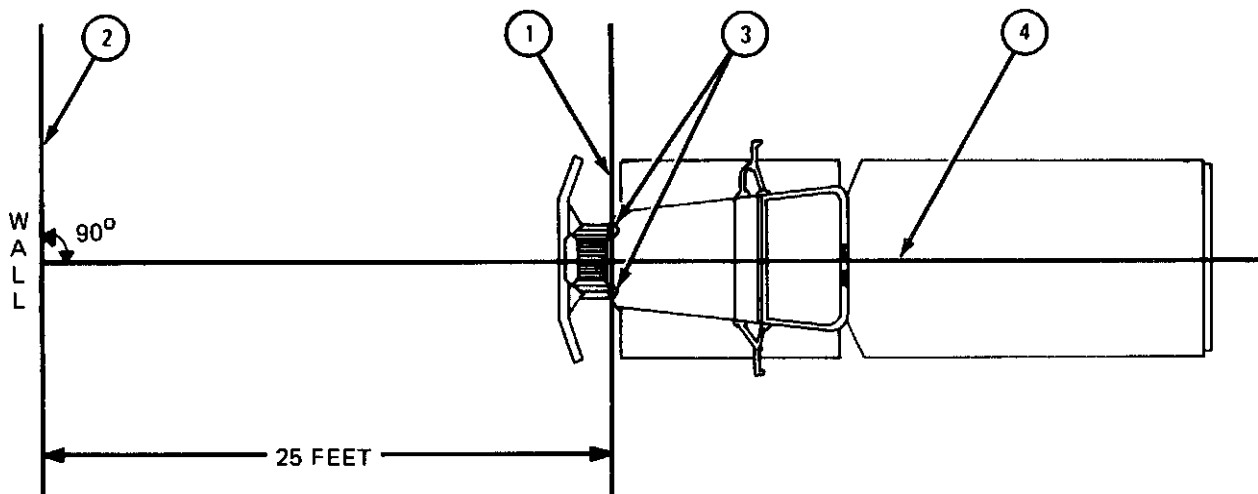

TA 101599

FRAME 2

1. Using tape measure, measure and note height from floor to center of left headlight (1).
2. Do step 1 again for right headlight.

GO TO FRAME 3

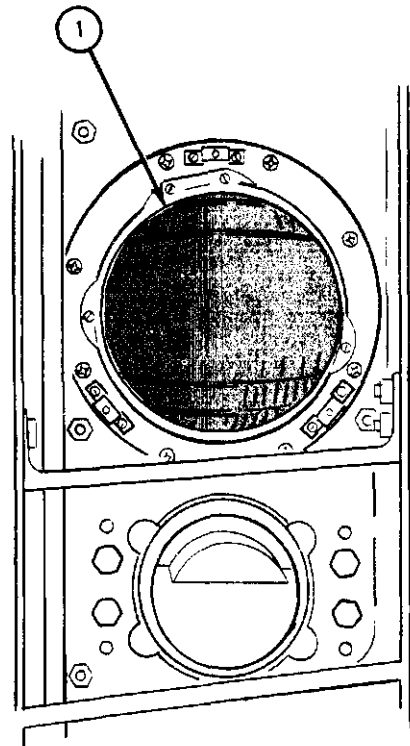
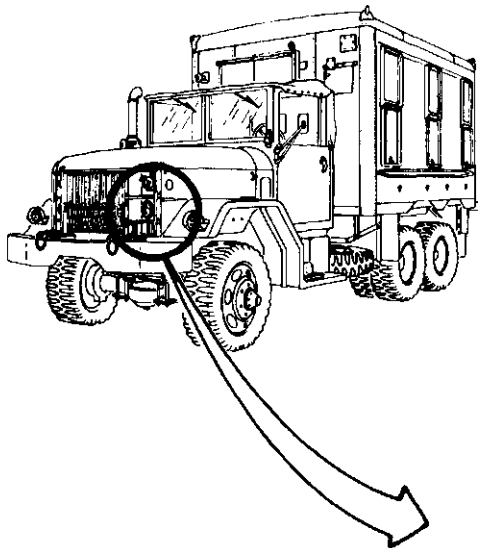

TA 101589

FRAME 3

- 1. Mark height from floor (1) noted in frame 2 on wall. Using chalk, draw line X-X parallel to floor.
- 2. Using chalk, draw line A-A 1/12 the distance from line X-X to floor (1).

GO TO FRAME 4

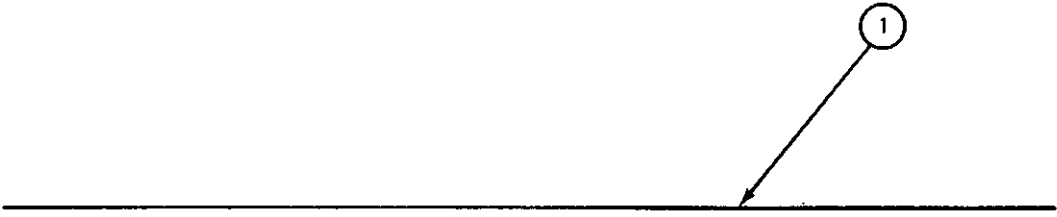
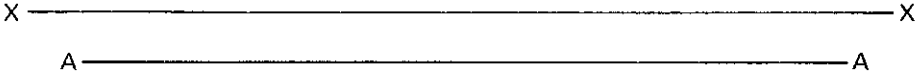

TA 101590

FRAME 4

- Soldier A 1. Hold string (1) in center of right headlight (2).
- Soldier B 2. Hold other end of string (1) tight on wall (3) on line X-X drawn in frame 3.
- Soldier c 3. Place and hold carpenter's square (4) flush against wall (3) on line X-X drawn in frame 3.

GO TO FRAME 5

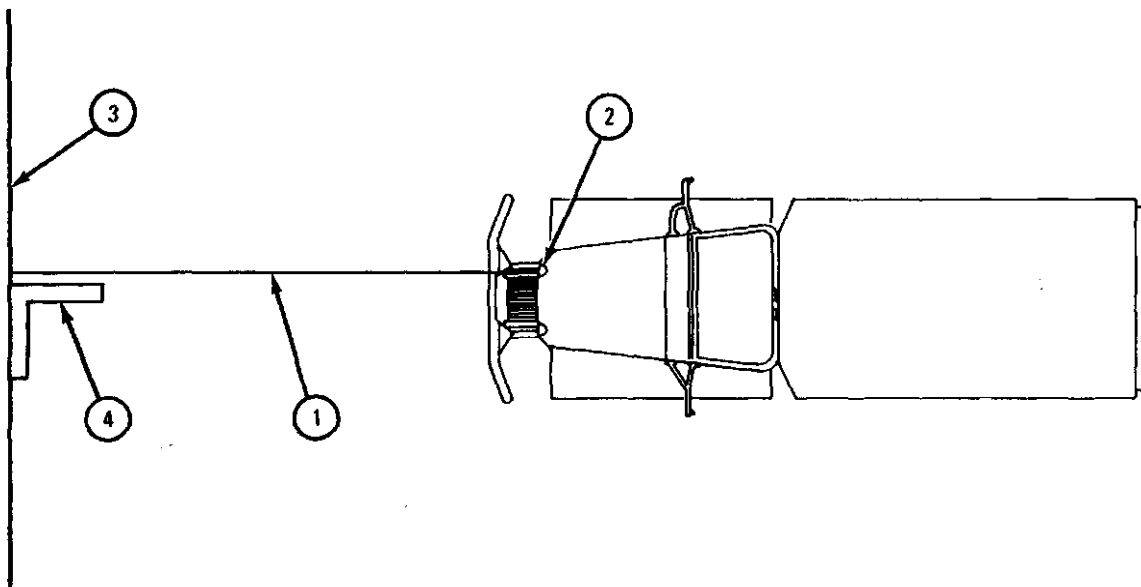

TA 101591

FRAME 5

- Soldiers B and C 1. Slide carpenter's square (1) and move string (2) on line X-X until string is flush with edge of carpenter's square. String will be at right angle (90°) to wall (3).
- Soldier C 2. Using chalk, mark point D of line X-X where string (2) is flush with edge of carpenter's square.
- Soldiers A, B, and C 3. Do steps 1 and 2 again for line A-A and point E.
4. Using chalk, draw line C-C through points D and E.

GO TO FRAME 6

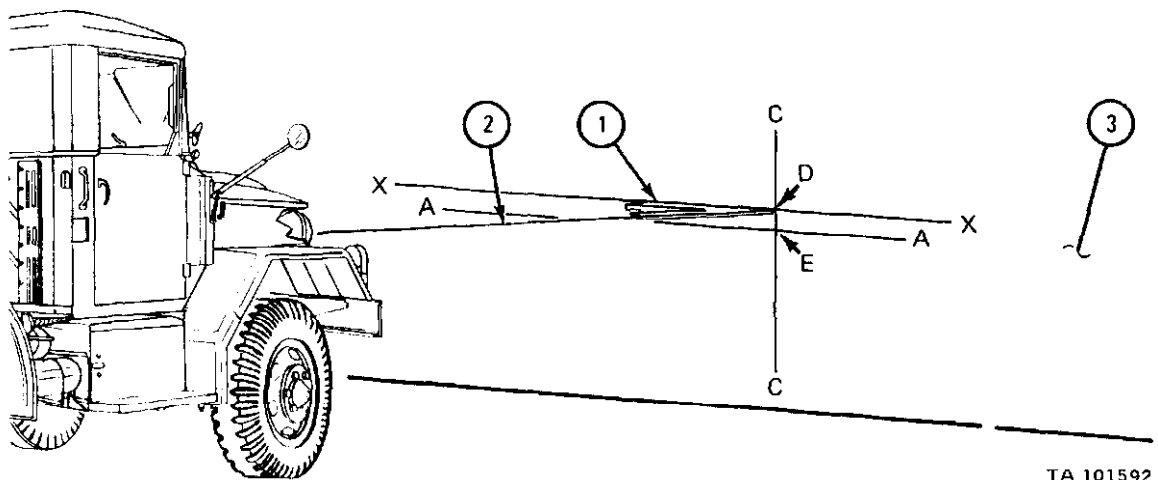

TA 101592

FRAME 6

- Soldiers A and B 1. Using tape measure, measure distance from center of right headlight (1) to center of left headlight (2). Note distance.
- Soldiers B and C 2. Using tape measure and chalk, mark point F as shown on line X-X at distance noted in step 1 from point D.
3. Using tape measure and chalk, mark point G as shown on line A-A at distance noted in step 1 from point E.
4. Using chalk, draw line B-B through points F and G.

GO TO FRAME 7

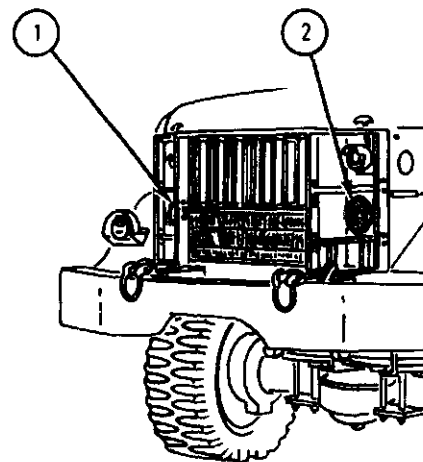
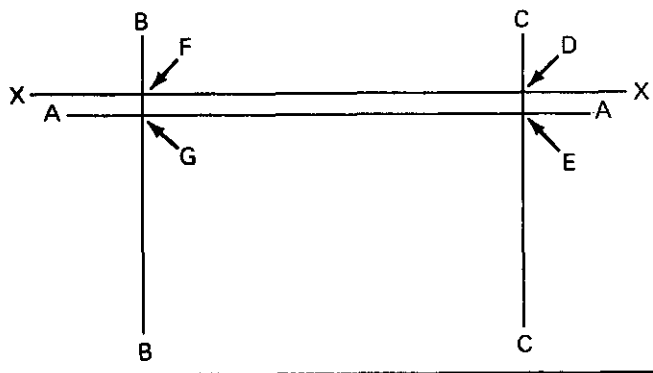

TA 101593

FRAME 7

NOTE

If working on early model trucks, do step 1.

1. Using flat-tip screwdriver, unscrew and take out three screws (1). Take off rim (2).
2. Turn on headlights and high beams. Refer to TM 9-2320-209-10.
3. Cover right headlight.
4. Center of left headlight hot spot (3) should be where lines A-A and B-B meet as shown.
5. Using flat-tip screwdriver, turn screw (4) to move hot spot (3) left or right to put center as shown.
6. Using flat-tip screwdriver, turn screw (5) to move hot spot (3) up or down to put center as shown.
7. Uncover right headlight.
8. Do steps 2 through 6 again for right headlight, covering left headlight and using lines C-C and A-A.
9. Shut off high beams and headlights. Refer to TM 9-2320-209-10.

END OF TASK

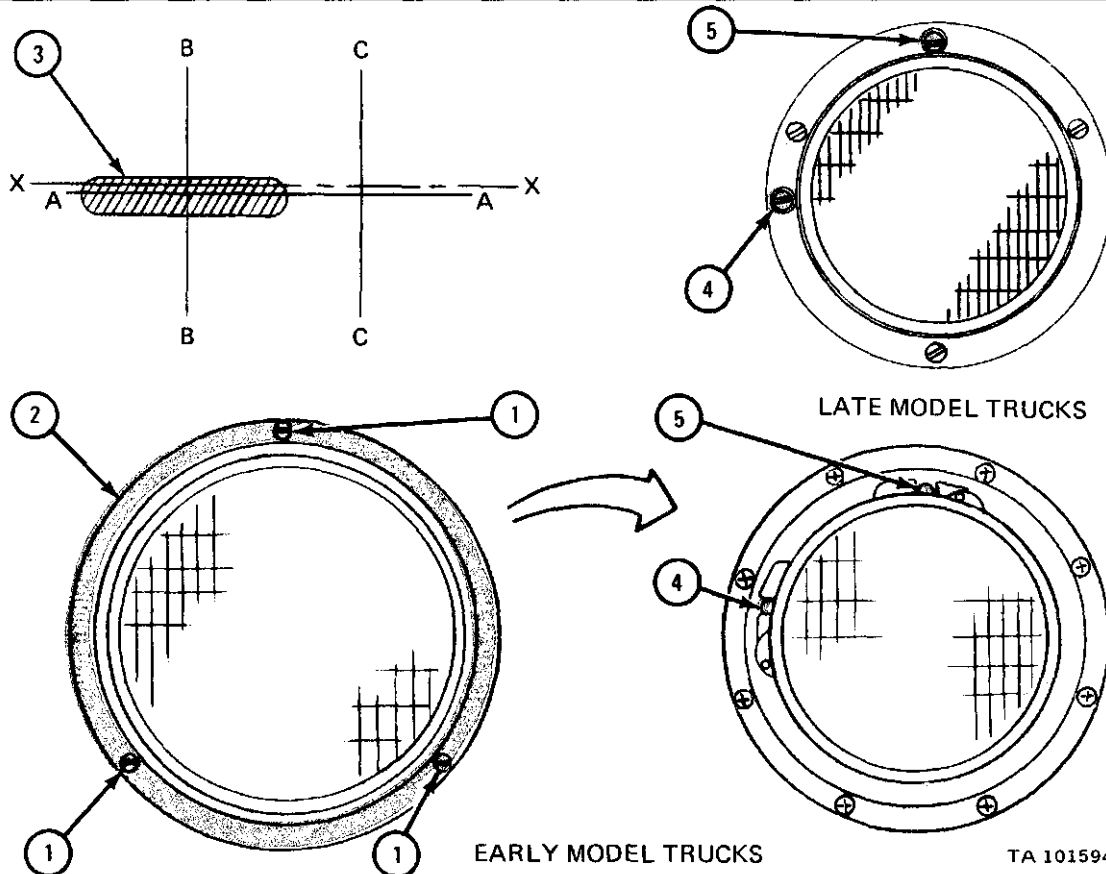

7-20. FRONT SERVICE SEALED BEAM REMOVAL AND REPLACEMENT.

TOOLS: Flat-tip screwdriver

SUPPLIES: Tags

PERSONNEL: One

EQUIPMENT CONDITION: Truck parked, engine off, handbrake set, light switch in OFF position.

a. Removal.

FRAME 1

1. Using screwdriver, unscrew and take out three screws (1) from headlight mounting ring (2). Take off mounting ring.
2. Using screwdriver, loosen three screws (3) from sealed beam retaining ring (4). Hold sealed beam (5) in place and turn retaining ring to left and take it off.

NOTE

Tag wires (6) so they will be put back in same places.

3. Pull out sealed beam (5) and unplug three plugs (7).

END OF TASK

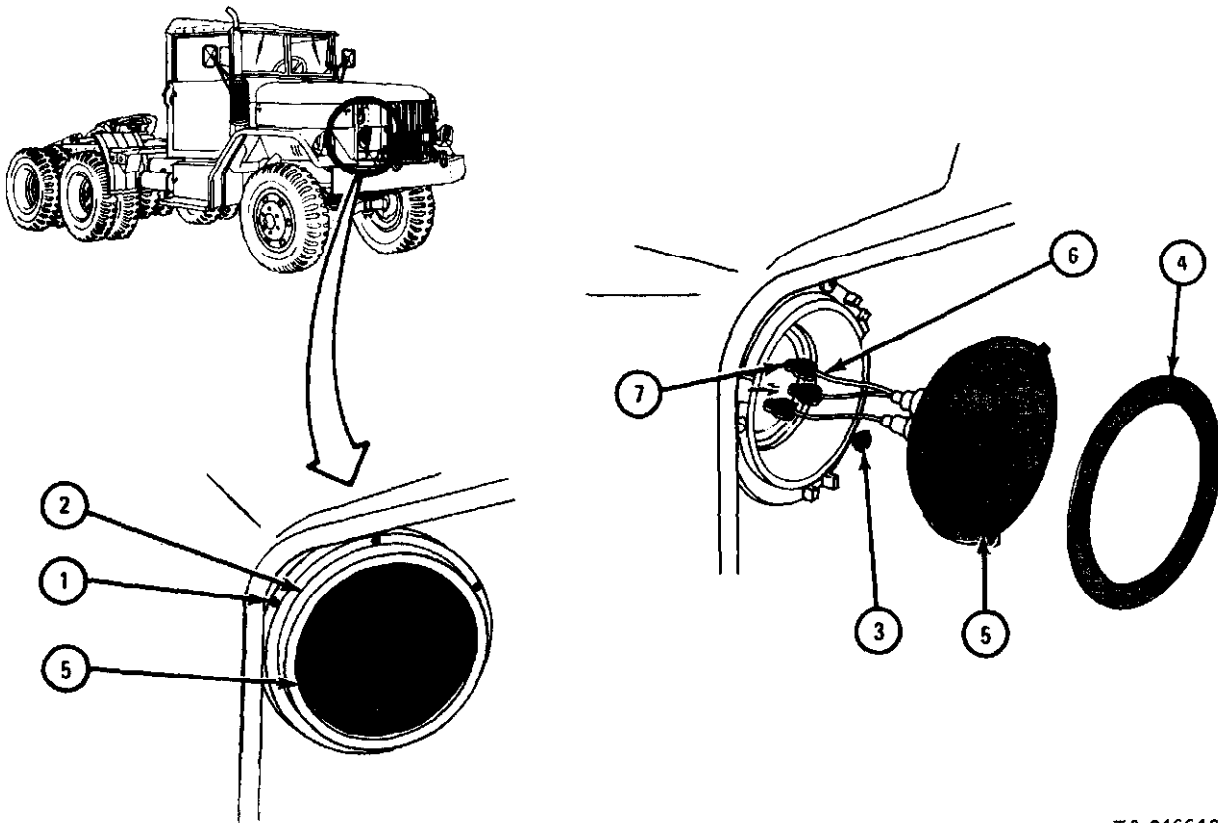

TA 046642

b. Replacement.**FRAME 1**

1. Plug in three plugs (1) as tagged. Take off tags.
2. Put sealed beam (2) in ring assembly (3) and aline three tabs (4) with three notches (5) on sealed beam.

NOTE

Make sure that drain hole in retaining assembly (retaining ring and mounting ring) is placed at the bottom.

3. Put retaining ring (6) on three screws (7). Push it in and turn it to right. Using screwdriver, tighten three screws (7).
4. Put mounting ring (8) over sealed beam (2), alining holes.
5. Using screwdriver, screw in and tighten three screws (9).

END OF TASK

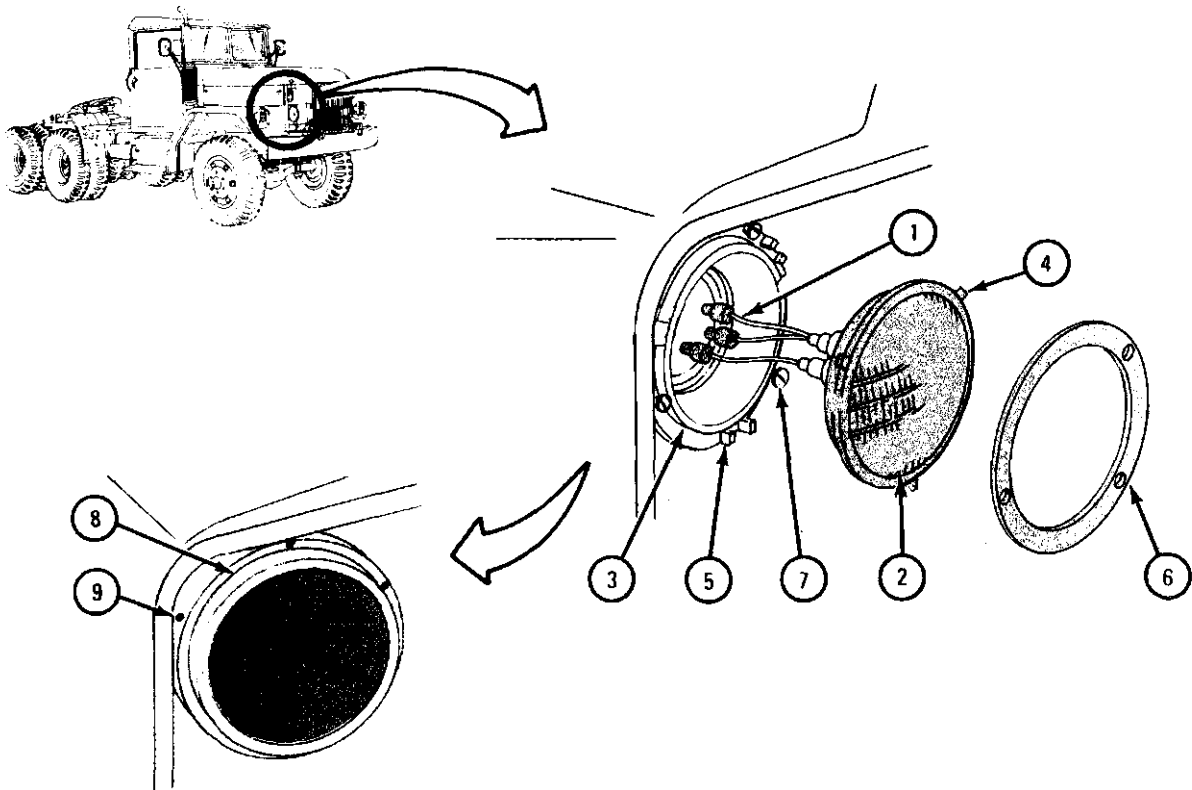

TA 046643

7-21. BLACKOUT DRIVE LIGHT ASSEMBLY AND BRACKET REMOVAL AND REPLACEMENT (TRUCKS WITH WINCH).

NOTE

The blackout drive light assembly is mounted below the headlight assembly.

TOOLS: 7/16-inch wrench (2)
9/16-inch wrench

SUPPLIES: None

PERSONNEL: One

EQUIPMENT CONDITION: Truck parked, engine off, handbrake set, light switch in OFF position.

a. Preliminary Procedure. Open hood and left side panel. Refer to TM 9-2320-209-10.

b. Removal.

FRAME 1

1. Unplug electrical connector (1) from connector (2).
2. Using 9/16-inch wrench, unscrew and take off nut (3), lockwasher (4), ground wire (5), and mounting washer (6).
3. Take out blackout drive light assembly (7) from mounting bracket (8).

GO TO FRAME 2

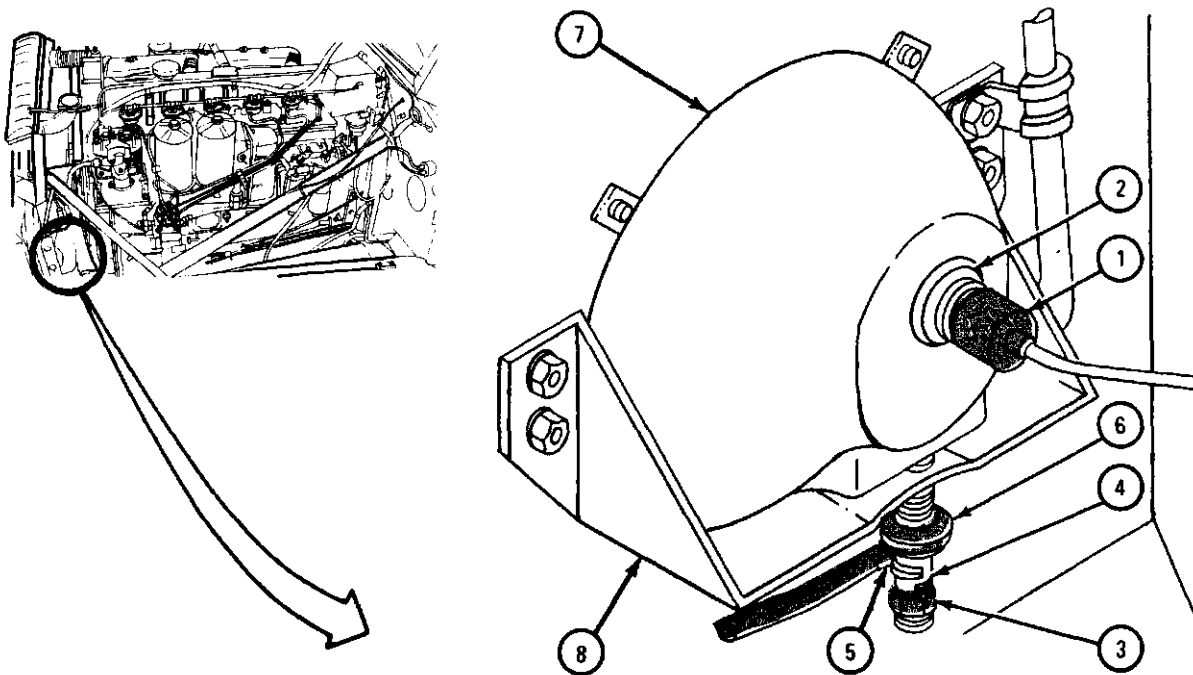

TA 046665

FRAME 2

1. Using 7/16-inch wrenches, unscrew and take off nut (1).
2. Take off clamp (2) and move wire (3) to right side.
3. Using 7/16-inch wrenches, unscrew and take off three nuts (4). Take off mounting bracket (5).
4. Using 7/16-inch wrench, unscrew and take off four nuts (6). Take out four studs (7).

END OF TASK

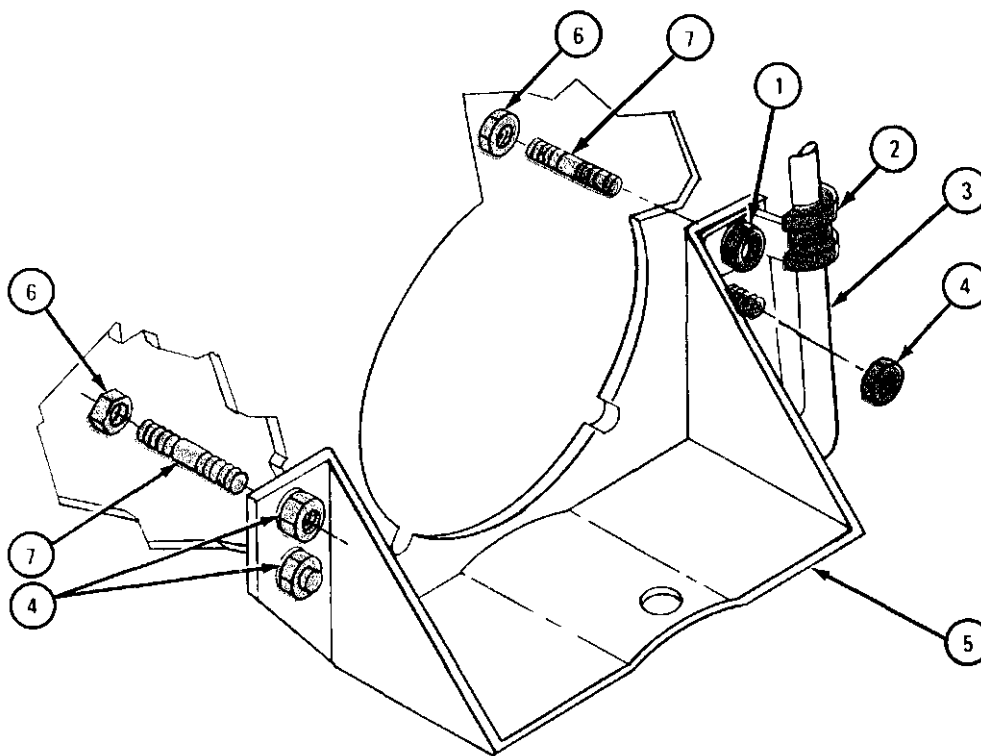

TA 046666

c. Replacement.

FRAME 1

1. Put two studs (1) in place on left side of headlight mounting support (2).
2. Using 7/16-inch wrenches, screw on and tighten two nuts (3).
3. Put two studs (4) in place on right side of headlight mounting support (2).
4. Using 7/16-inch wrenches, screw on and tighten two nuts (5).

GO TO FRAME 2

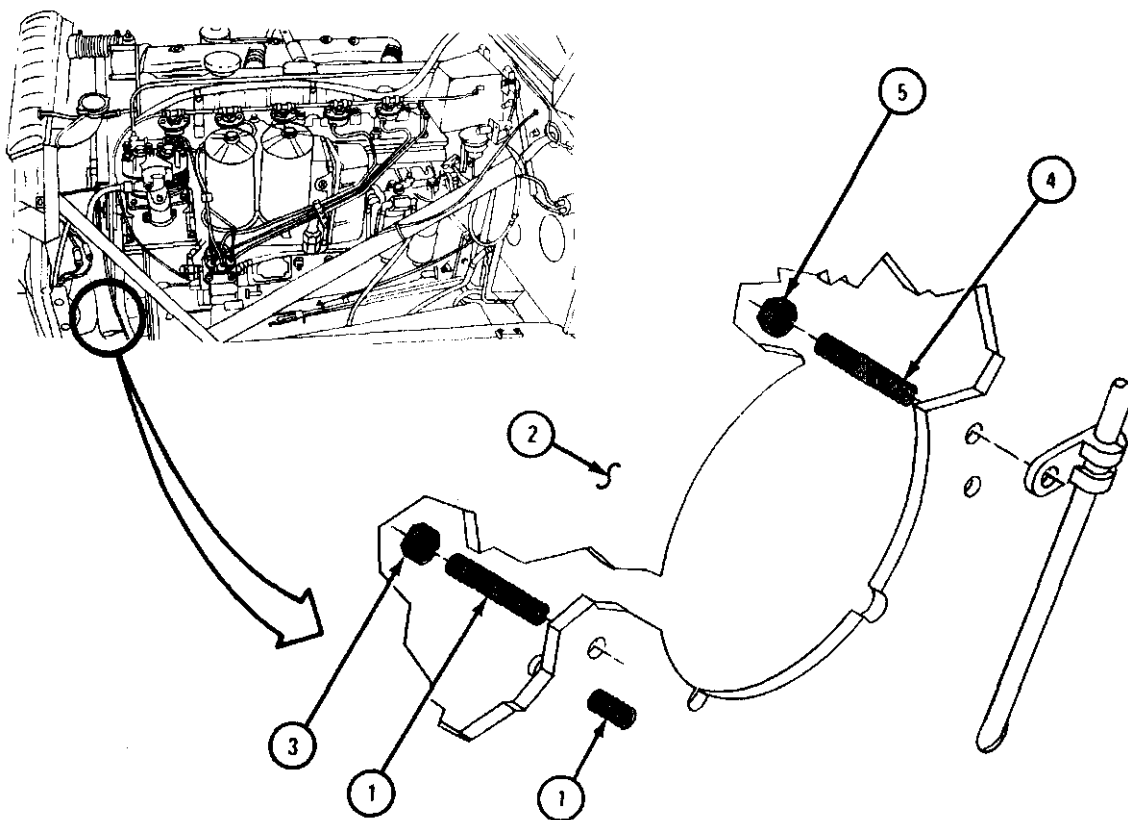

TA 046667

FRAME 2

1. Aline four holes in bracket (1) with four mounting studs (2). Put bracket (1) onto four mounting studs.
2. Using 7/16-inch wrenches, screw on and tighten three nuts (3).
3. Put clamp (4) with wire (5) onto stud (2) as shown.
4. Using 7/16-inch wrench, screw on and tighten nut (6).

GO TO FRAME 3

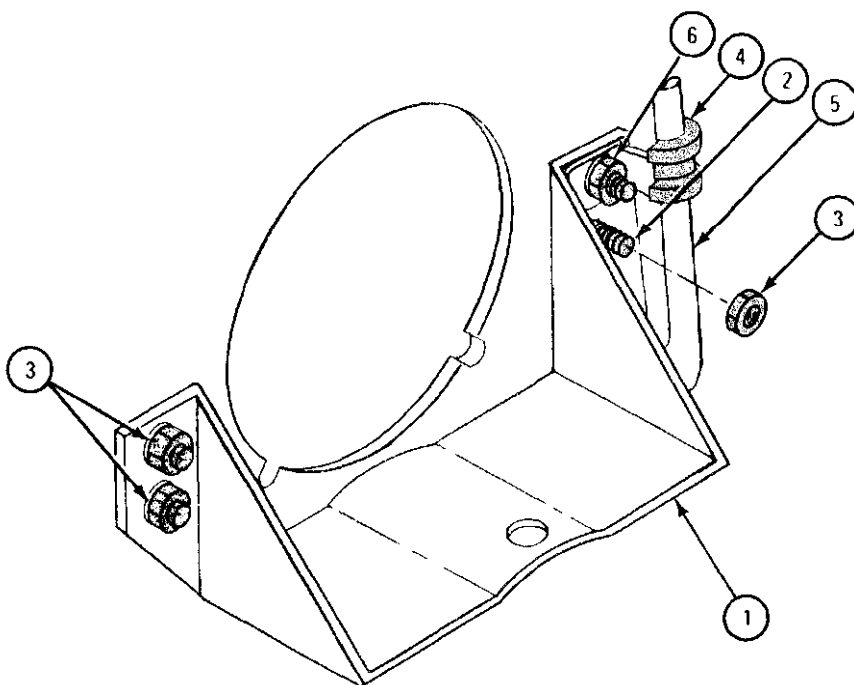

TA 085538

FRAME 3

1. Put light assembly (1) on mounting bracket (2).
2. Using 9/16-inch wrench, screw on and tighten mounting washer (3), ground wire (4), lockwasher (5), and nut (6).
3. Plug in electrical connector (7) to connector (8).

NOTE

Follow-on Maintenance Action Required:

Close hood and side panel. Refer to TM 9-2320-209-10.

END OF TASK

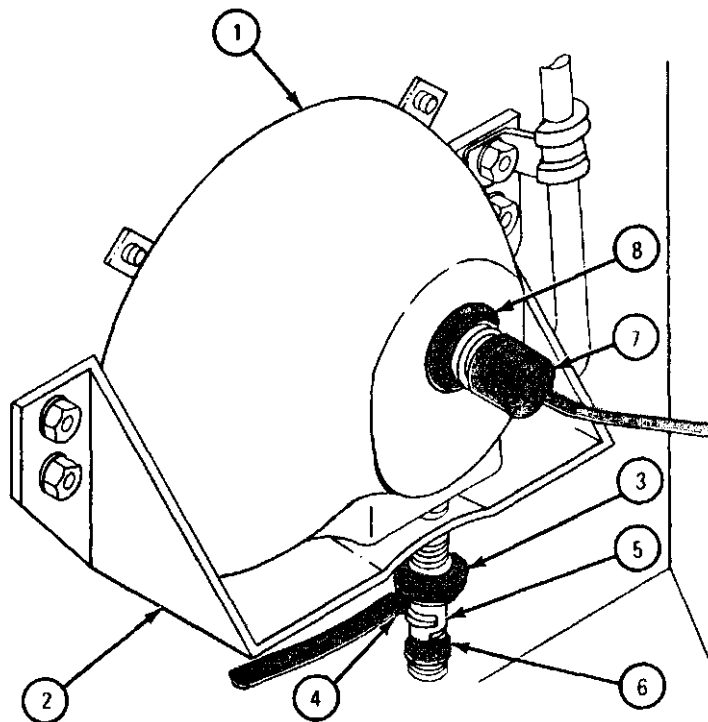

TA 046668

7-22. BLACKOUT DRIVE LIGHT ASSEMBLY AND BRACKET REMOVAL AND REPLACEMENT (TRUCKS WITHOUT WINCH).

NOTE

The blackout drive light assembly is mounted above the headlight assembly.

TOOLS: 7/16-inch wrench
9/16-inch wrench

SUPPLIES: None

PERSONNEL: One

EQUIPMENT CONDITION: Truck parked, engine off, handbrake set.

Preliminary Procedure. Open hood and left side panel. Refer to TM 9-2320-209-10.

b. Removal.

FRAME 1

1. Unplug electrical connector (1) from connector (2).
2. Using 9/16-inch wrench, unscrew and take off nut (3), lockwasher (4), ground wire (5), and mounting washer (6).
3. Take out blackout drive light assembly (7) from mounting bracket (8).

GO TO FRAME 2

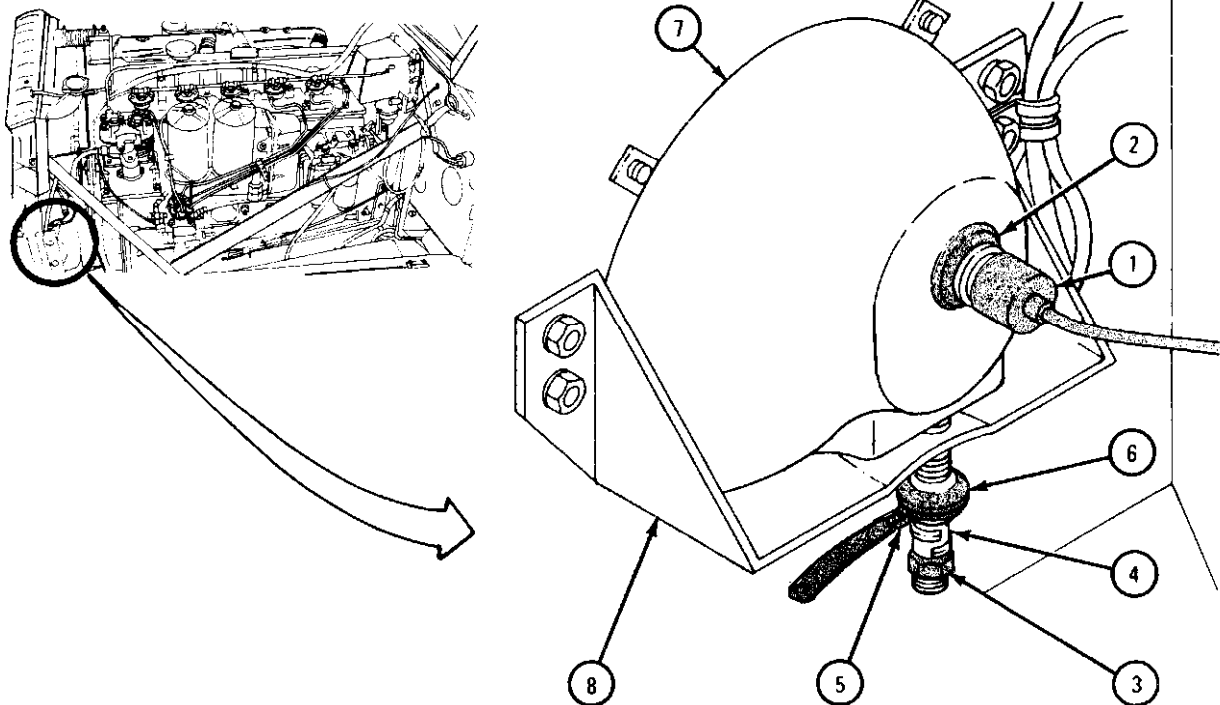

TA 080954

FRAME 2

1. Using 7/16-inch wrench, unscrew and take off four nuts (1) and four lockwashers (2).
2. Take off wire clamp (3).
3. Take off mounting bracket (4).

END OF TASK

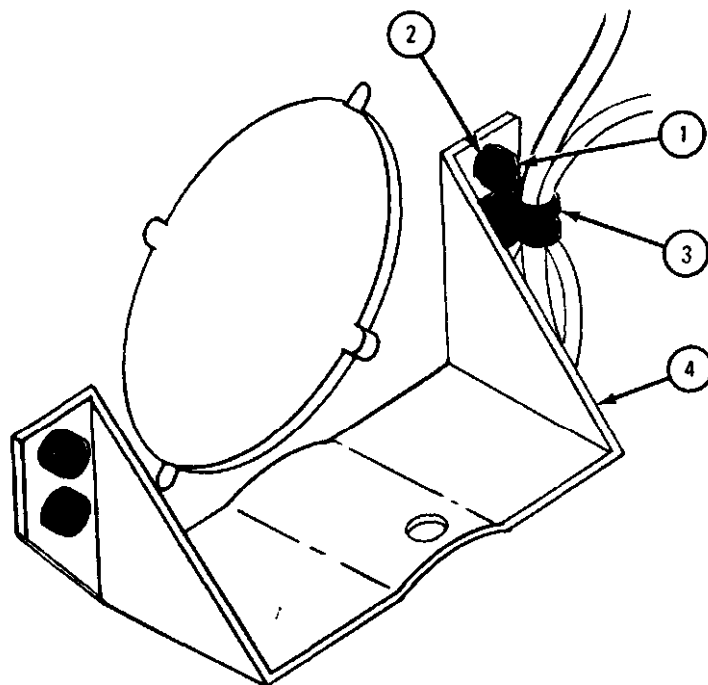

TA 080955

c. Replacement.

FRAME 1

1. Aline four holes in bracket (1) with four shock mount studs (2). Put wire clamp with wires (3) on shock mount stud as shown.
2. Using 7/16-inch wrench, screw on and tighten four lockwashers (4) and nuts (5).

GO TO FRAME 2

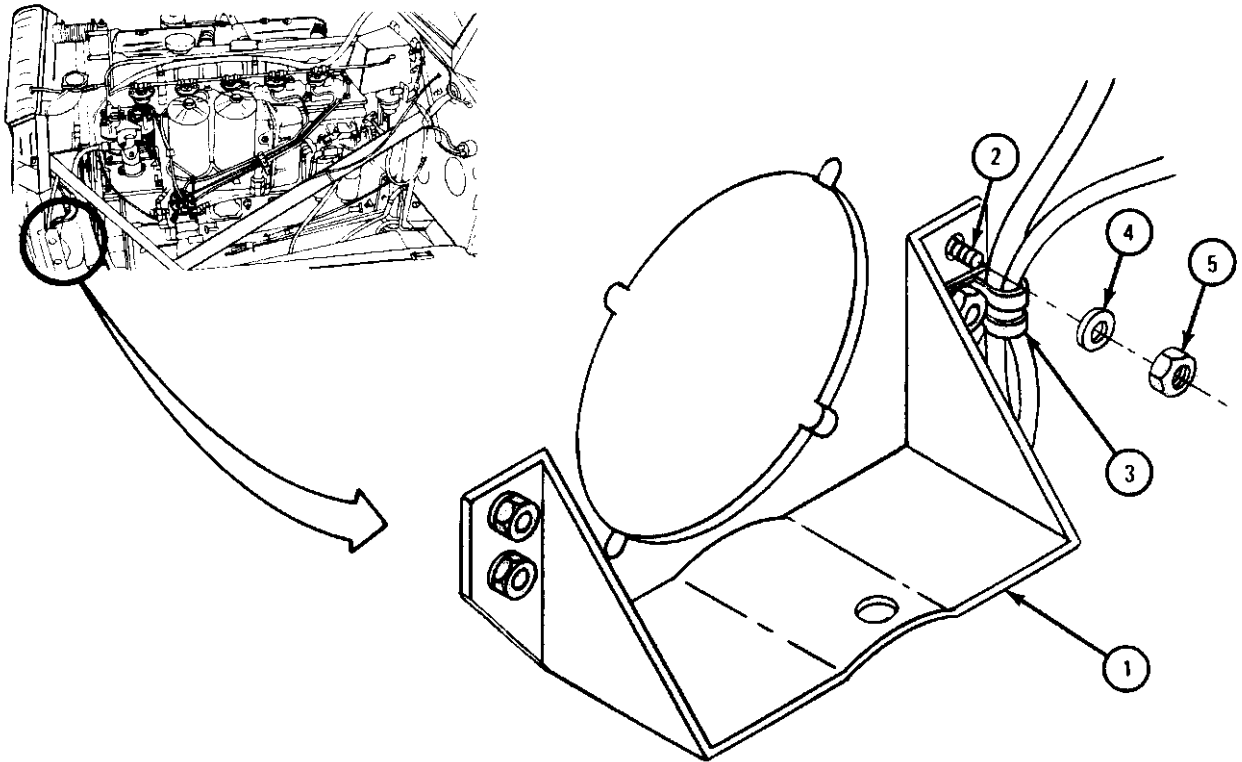

TA 080956

FRAME 2

1. Put light assembly (1) on mounting bracket (2).
2. Using 9/16-inch wrench, screw on and tighten mounting washer (3), ground wire (4), lockwasher (5), and nut (6).
3. Plug in electrical connector (7) to connector (8).

NOTE

Follow-on Maintenance Action Required:

Close hood and side panel. Refer to TM 9-2320-209-10.

END OF TASK

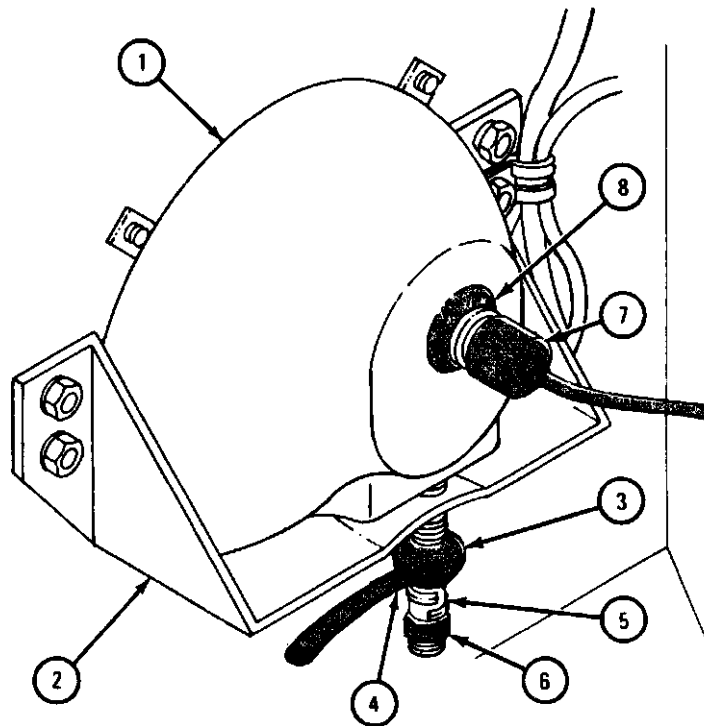

TA 080957

7-23. BLACKOUT DRIVE LIGHT SEALED BEAM UNIT REMOVAL AND REPLACEMENT.

TOOLS: Flat-tip screwdriver
6-inch long-nose pliers

SUPPLIES: None

PERSONNEL: One

EQUIPMENT CONDITION: Truck parked, engine off, handbrake set, light switch in OFF position.

a. Removal.

FRAME 1

1. Using screwdriver, unscrew and take out three screws (1).
2. Hold light door (2) with sealed beam (3) away from light body (4).
3. Unplug two electrical leads (5 and 6).
4. Take out sealed beam (3) and light door (2).

GO TO FRAME 2

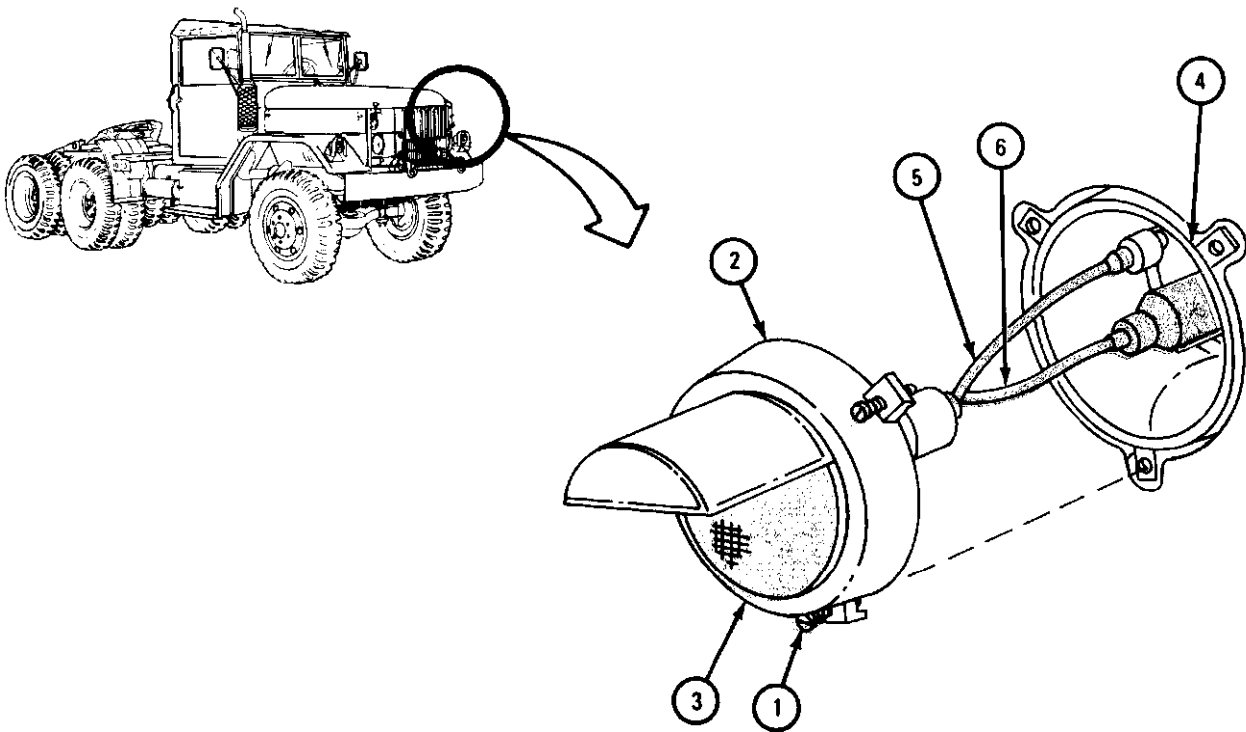

TA 046669

FRAME 2

WARNING

Retaining springs (1) may snap out and cause injury. Cover spring with free hand when prying it loose.

1. Using long-nose pliers, pry out three retaining springs (1) from light door (2).
2. Take out sealed beam (3) from light door (2).

END OF TASK

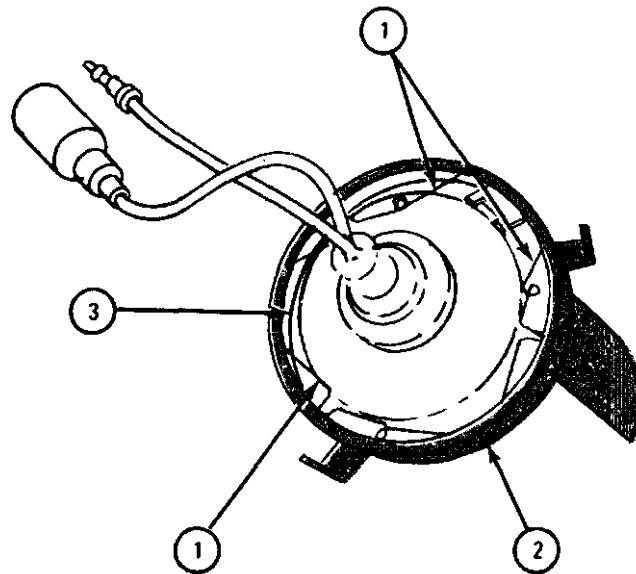

TA 046670

b. Replacement.

FRAME 1

WARNING

Retaining springs (1) may snap out and cause injury.
Cover spring with free hand when snapping it in place.

1. Put sealed beam (1) into light door (2), alining tab (3) on sealed beam with slot (4) on door.
2. Put in three evenly spaced retaining springs (5) by holding bend of spring over sealed beam and pressing free ends inside flange of light door (2).

GO TO FRAME 2

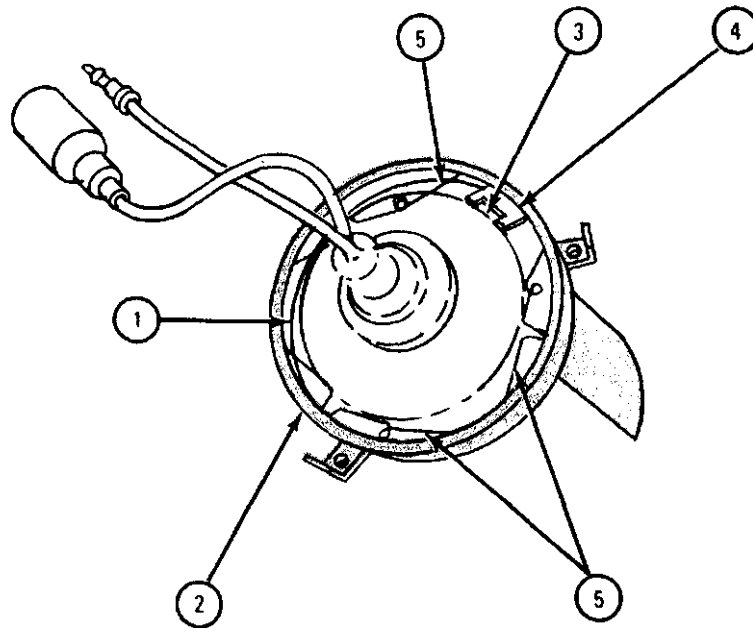

TA 046671

FRAME 2

1. Plug electrical lead (1) into connector (2).
2. Plug electrical lead (3) into connector (4).
3. Put light door (5) with sealed beam (6) on light body (7).
4. Using screwdriver, screw in and tighten three screws (8).

END OF TASK

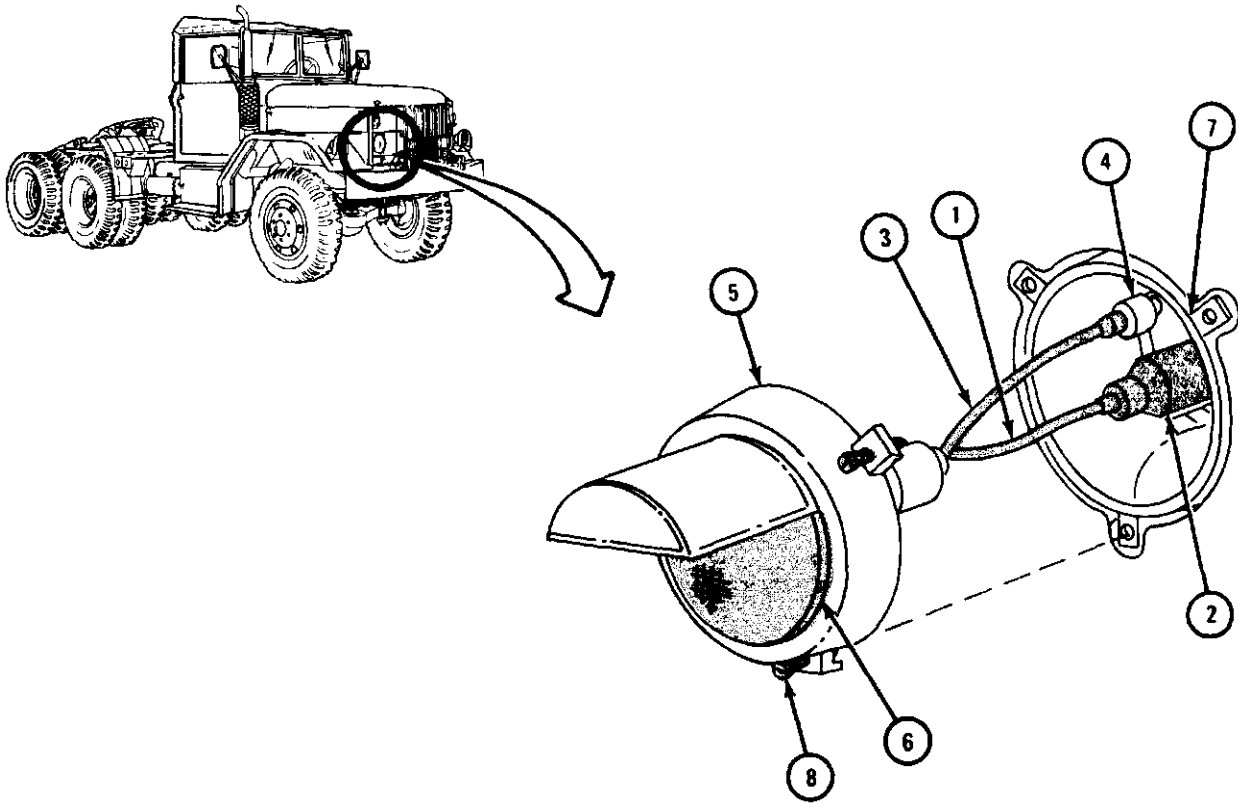

TA 046672

7-24. BLACKOUT DRIVE LIGHT ASSEMBLY REPAIR,

TOOLS: None

SUPPLIES: Electrical contact cleaner, MS 230
Solvent, dry cleaning, type II (SD-2), Fed. Spec P-D-680

PERSONNEL: One

EQUIPMENT CONDITION: Truck parked, engine off, handbrake set, light
switch in OFF position.

a. Preliminary Procedures.

- (1) Remove blackout drive light assembly.
 - (a) For trucks with winch, refer to para 7-21.
 - (b) For trucks without winch, refer to para 7-22.
- (2) Remove blackout sealed beam light door. Refer to para 7-23.

b. Cleaning, Inspection, and Repair.

FRAME 1

WARNING

Dry cleaning solvent is flammable. Do not use near an open flame. Keep a fire extinguisher nearby when solvent is used. Use only in well-ventilated places. Failure to do this may result in injury to personnel and damage to equipment.

1. Using solvent, clean all metal parts.
2. Clean wires with water damp rag and wipe dry. Clean connectors (1 and 2) with contact cleaner.
3. Check housing (3) and light door (4) for dents, cracks or other damage.
4. Check sealed beam unit (5) for a burned out filament, damaged wires or connectors (1 and 2).
5. Check retaining springs (6) for damage. Throw away all damaged parts.

NOTE

Follow-on Maintenance Action Required:

1. Put sealed beam unit and light door back on housing. Refer to para 7-23.
2. Put blackout drive light assembly back on trucks with winch. Refer to para 7-21.
3. Put blackout drive light assembly back on trucks without winch. Refer to para 7-22.

END OF TASK

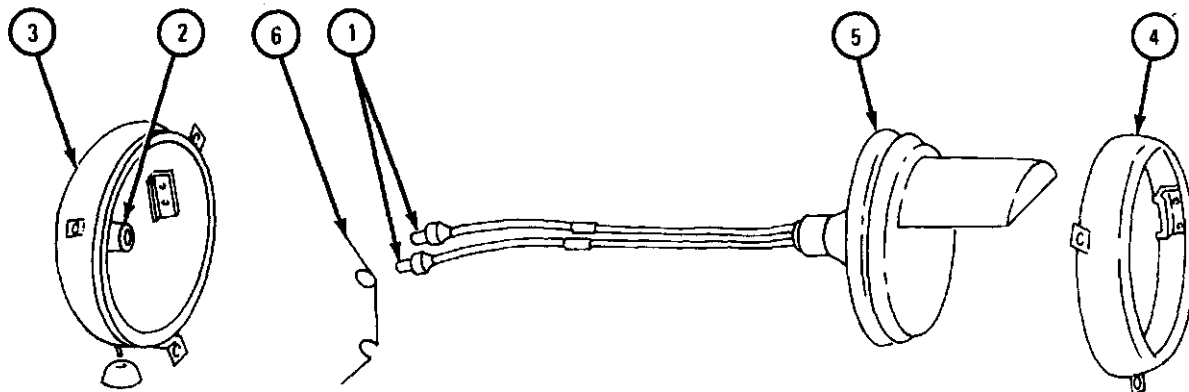

TA 085590

7-25. TAILLIGHT AND STOPLIGHT ASSEMBLY (RIGHT SIDE ONLY) REMOVAL AND REPLACEMENT (EARLY MODEL TRUCKS WITH TURN SIGNALS).

NOTE

The blackout stoplight is mounted on top of bracket on some trucks and on bottom of bracket on other trucks. This task is for truck M756A2. It can be used for other trucks.

TOOLS: 9/16-inch wrench

SUPPLIES: Tags

PERSONNEL: One

EQUIPMENT CONDITION: Truck parked, engine off, handbrake set, main light switch in OFF position.

- a. Preliminary Procedure. Remove blackout stoplight assembly. Refer to para 7-31.
- b. Removal.

FRAME 1

NOTE

Tag three electrical lead plugs (1) so they will be put back the same way.

1. Unplug three electrical lead plugs (1) from wiring harness connectors (2).
2. Using 9/16-inch wrench, unscrew and take off two capscrews and lockwashers (3), clamp (4), and ground wire (5).
3. Take off blackout stoplight bracket (6) and taillight and stoplight assembly (7)

END OF TASK

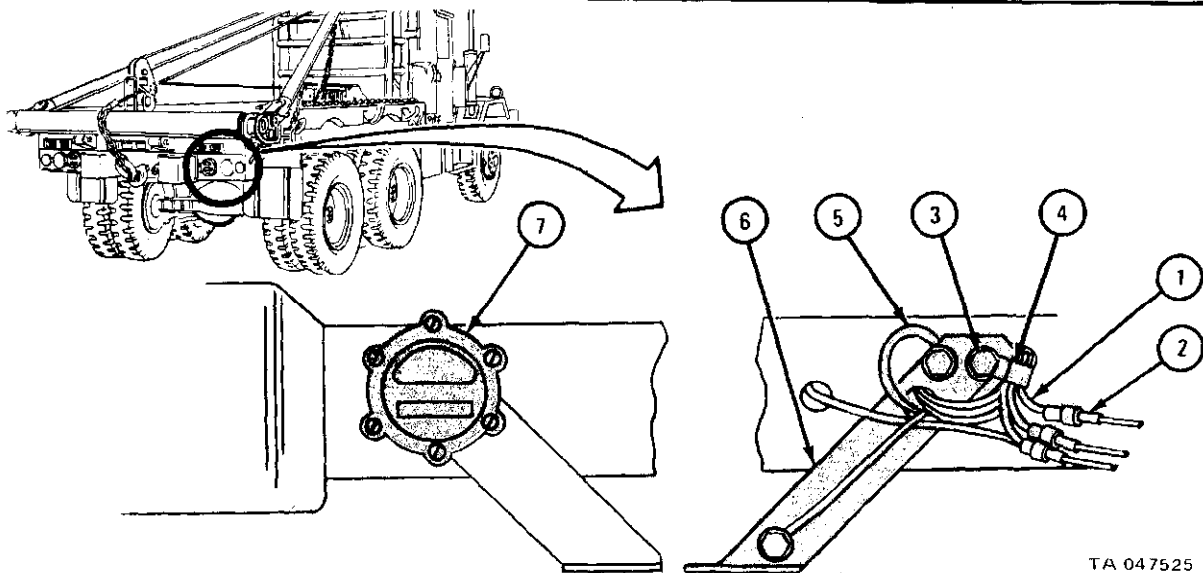

c. Replacement.

FRAME 1

1. Aline two holes in light assembly (1) with holes in light bracket (2) and holes in blackout stoplight bracket (3). Put ground wire (4) on capscrew and lockwasher (5) and screw in capscrew.
2. Put clamp (6) on wires (7) and aline clamp with hole. Using 9/16-inch wrench, screw in and tighten capscrew and lockwasher (8) and tighten capscrew(5).
3. Plug three electrical lead plugs (9) into harness connectors (10).
4. Take off tags.

NOTE

Follow-on Maintenance Action Required:

Replace blackout stoplight assembly. Refer to para 7-31.

END OF TASK

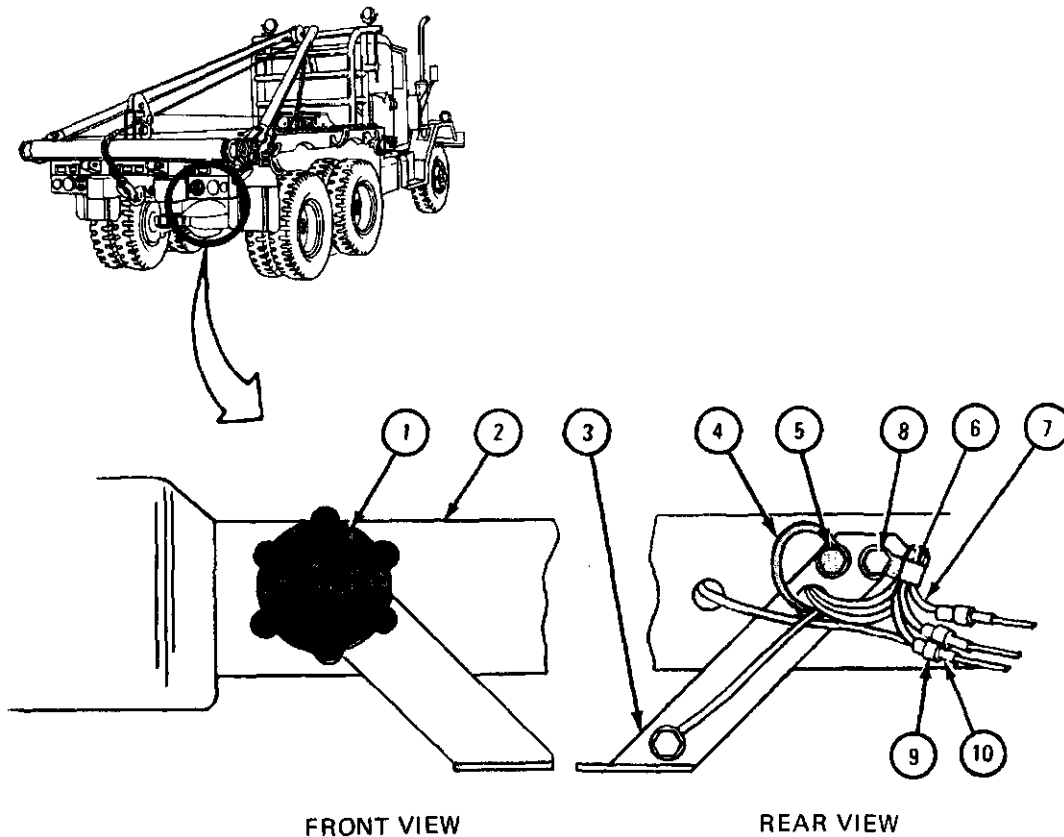

TA 047526

7-26. TAILLIGHT AND STOPLIGHT ASSEMBLY (RIGHT SIDE ONLY) REPAIR
(TRUCK M756A2).

TOOLS: Flat-tip screwdriver
Cross-tip screwdriver (Phillips type)

SUPPLIES: Mild soap
Electrical contact cleaner, MS 230

PERSONNEL: One

EQUIPMENT CONDITION: Truck parked, engine off, handbrake set, main light switch in OFF position.

a. Preliminary Procedures.

(1) Remove taillight and stoplight assembly and blackout stoplight bracket. Refer to para 7-25.

(2) Remove taillight and stoplight lamps. Refer to para 7-27.

b. Disassembly.

FRAME 1

1. Using flat-tip screwdriver, unscrew and take out two screws (1) with lockwashers (2).
2. Using phillips screwdriver, unscrew and take out three screws (3).
3. Take out socket assembly with wiring (4) from light housing (5).

END OF TASK

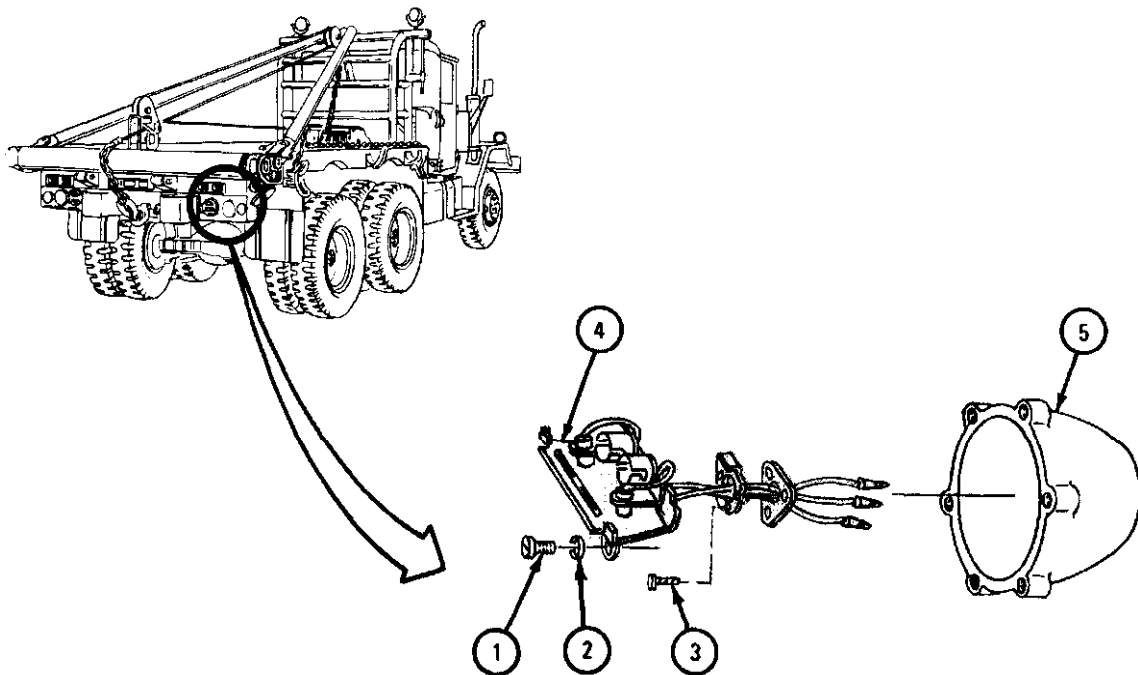

TA 047529

c. Cleaning, Inspection, and Repair.

FRAME 1

1. Using water and mild soap, clean light door and lens (1).
2. Check that lens and light door have no cracks, dents or other damage.

WARNING

Dry cleaning solvent is flammable. Do not use near an open flame. Keep a fire extinguisher nearby when solvent is used, Use only in well-ventilated places. Failure to do this may result in injury to personnel and damage to equipment.

3. Using electrical contact cleaner, clean all electrical contacts on socket assembly (2). Clean all other parts except wires and, gasket (3) using solvent.
4. Check that gasket (3) has no cracks, nicks or breaks.
5. Check that lamps (4) have no burned out filaments or corroded contacts.
6. Check that socket assembly with wiring (2) has no corroded contacts or broken or damaged wires and insulation.
7. Check that grommet (5) has no cracks or breaks.
8. Check that light housing (6) has no dents, cracks, stripped threads or other damage.
9. Check that all screws have no stripped or damaged threads.
10. Throw away all damaged parts and get new parts in their place.

END OF TASK

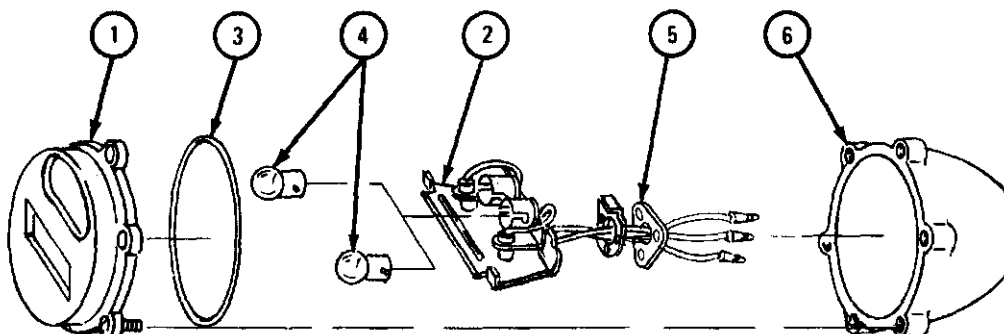

TA 047505

d. Assembly.

FRAME 1

1. Put socket assembly with wiring (1) into light housing (2) and pull wires through hole in light housing.
2. Using phillips screwdriver, screw in and tighten three screws (3).
3. Using flat-tip screwdriver, screw in and tighten two screws (4) and lockwashers (5).

NOTE

Follow-on Maintenance Action Required:

1. Replace taillight and stoplight lamps. Refer to para 7-27.
2. Replace taillight and stoplight assembly and blackout stoplight bracket. Refer to para 7-25.

END OF TASK

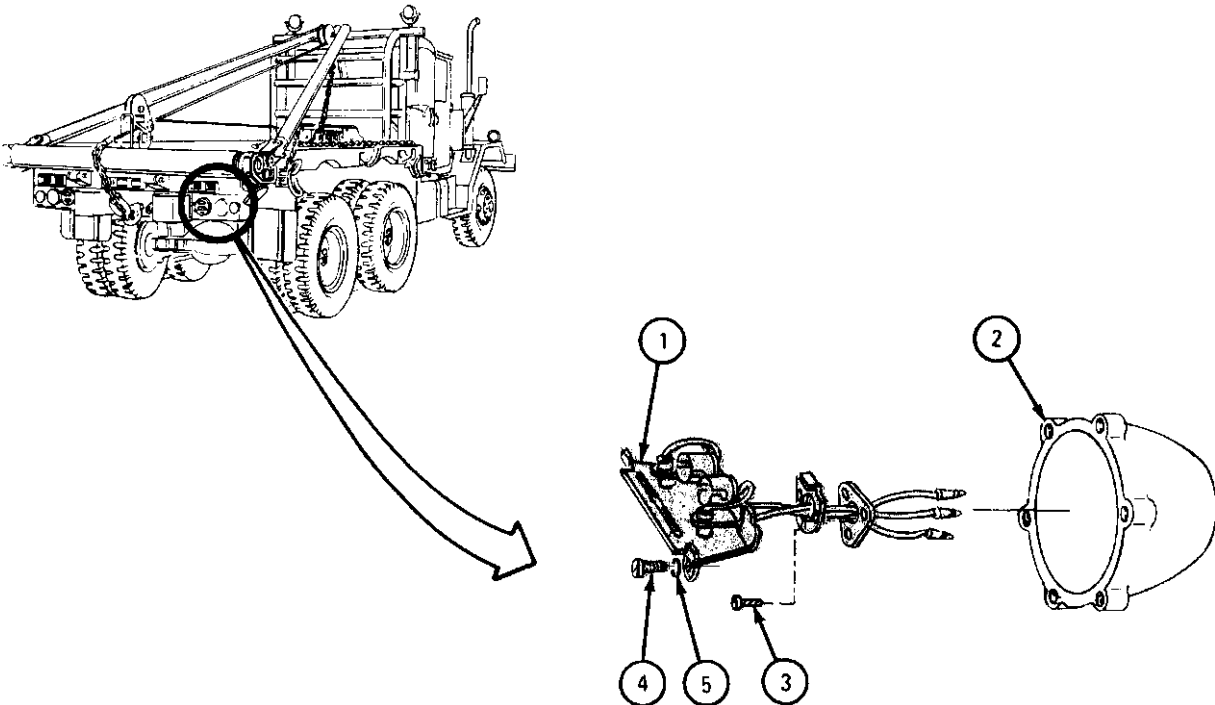

TA 047530

7-27. TAILLIGHT AND STOPLIGHT LAMPS (RIGHT SIDE ONLY) REMOVAL AND REPLACEMENT.

TOOLS: Flat-tip screwdriver

SUPPLIES: None

PERSONNEL: One

EQUIPMENT CONDITION: Truck parked, engine off, handbrake set, main light switch in OFF position.

a. Removal.

FRAME 1

1. Using screwdriver, unscrew and take off six screws (1). Take off light door with gasket (2).
2. Take out two small lamps (3) and large lamp (4) by pushing them in and turning them to left.

END OF TASK

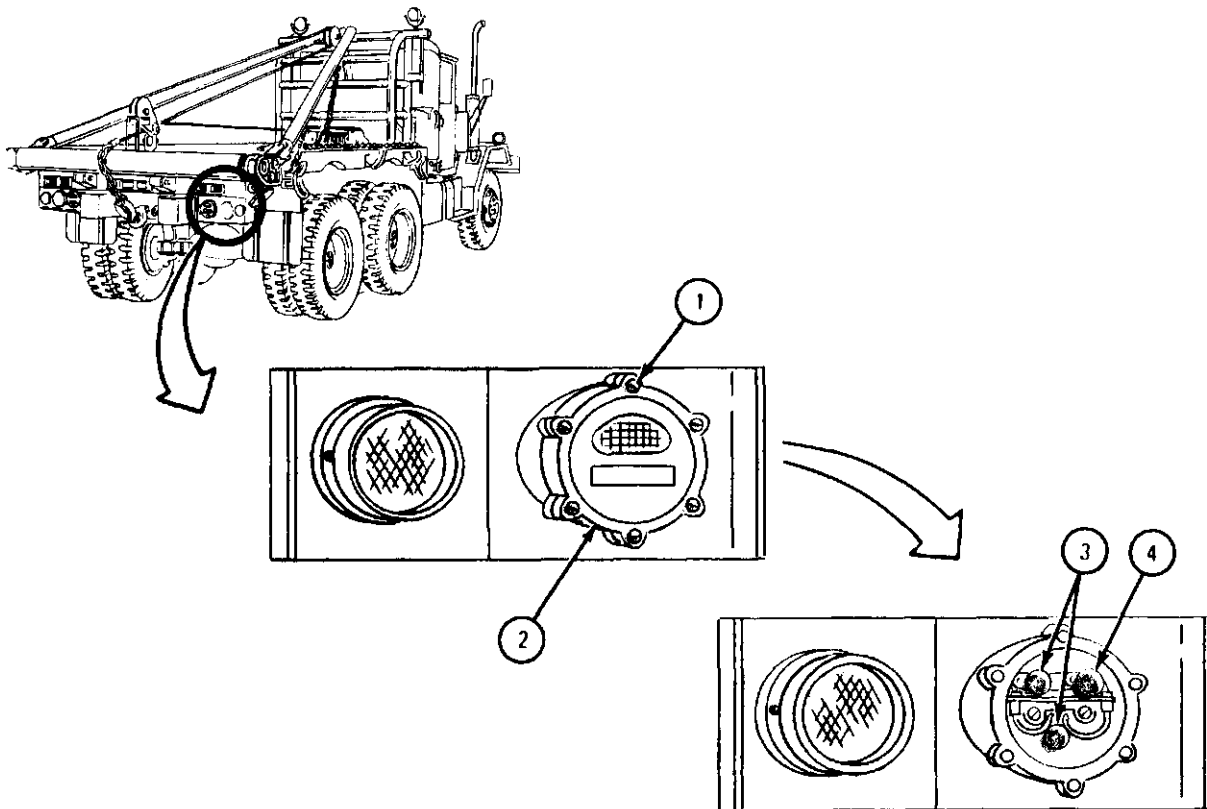

TA 047527

b. Replacement.**FRAME 1**

1. Push two small lamps (1) and large lamp (2) into three sockets (3) and turn them to right.
2. Place gasket (4) into groove and light door (5).
3. Put light door (5) on light housing (6).
4. Using screwdriver, screw in and tighten six screws (7).

END OF TASK

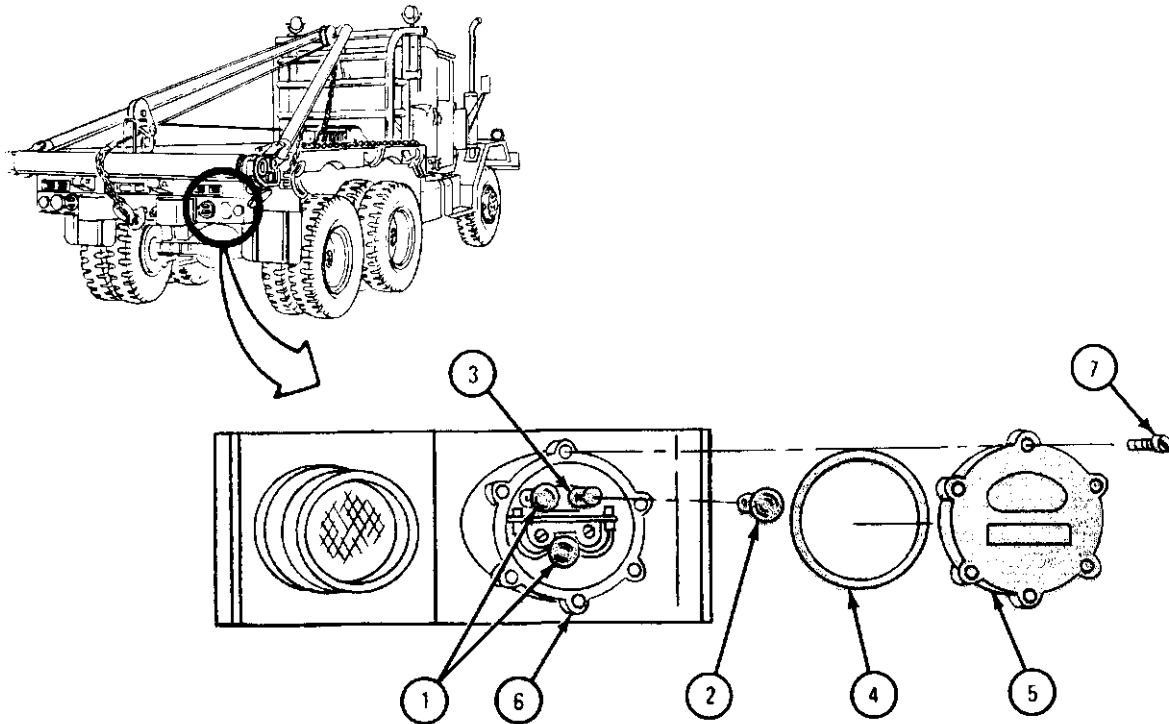

TA 047528

7-28. TAILLIGHT AND STOPLIGHT ASSEMBLY (LEFT SIDE ONLY) REMOVAL AND REPLACEMENT.

TOOLS : 9/16-inch wrench

SUPPLIES: Tags

PERSONNEL: One

EQUIPMENT CONDITION: Truck parked, engine off, handbrake set.

a. Removal.

FRAME 1

1. Using 9/16-inch wrench, unscrew and take off two capscrews (1), two lockwashers (2), ground wire (3), and clamp (4).

NOTE

Tag three wires (5) so they will be put back in the right place.

2. Unplug three wires (5), take clamp (4) off wires, and take off light assembly (6).

END OF TASK

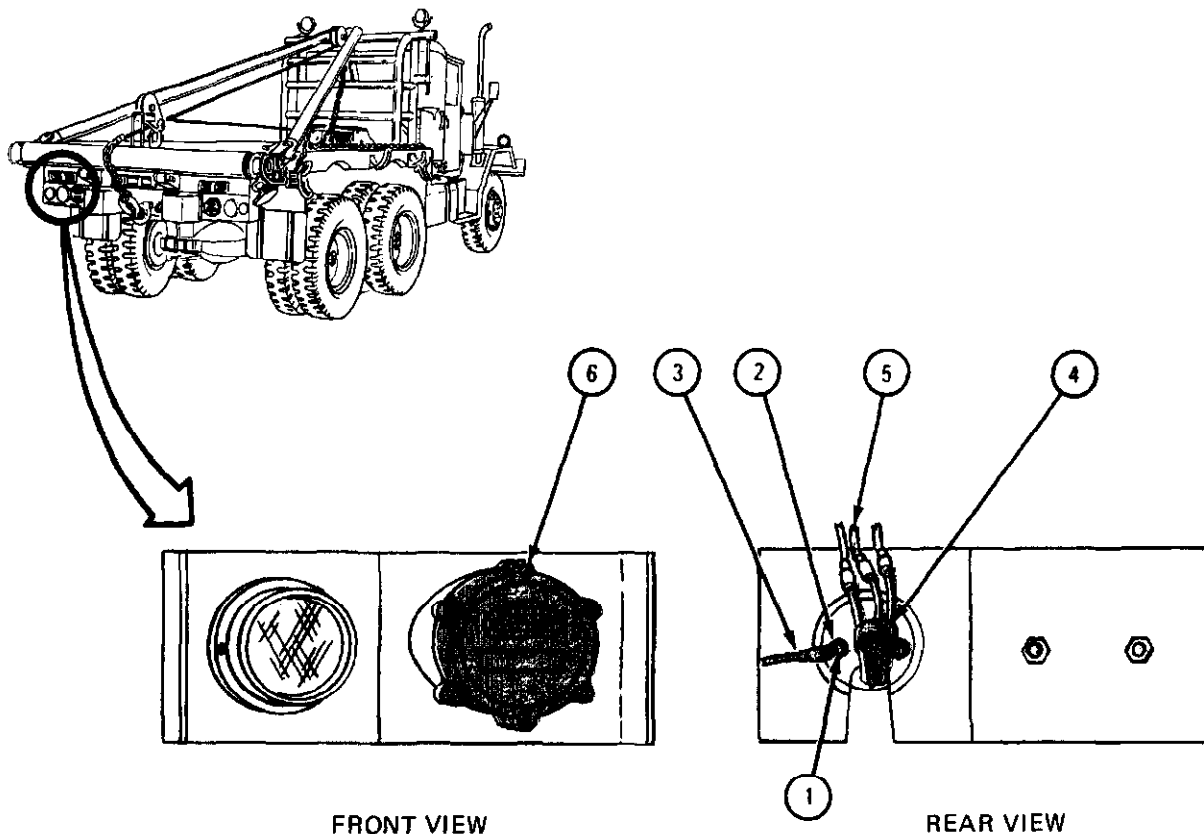

TA 046695

Replacement.**FRAME 1**

1. Put light assembly (1) in mounting bracket (2) with wires through bottom hole as shown in REAR VIEW.
2. Put clamp (3) on three wires (4).
3. Put clamp (3) into place and aline screw holes.
4. Using 9/16-inch wrench, screw in and tighten capscrew (5) and lockwasher (6).
5. Put ground wire (7) into place and aline screw holes. Using 9/16-inch wrench, screw in and tighten capscrew (8) and lockwasher (9).

END OF TASK

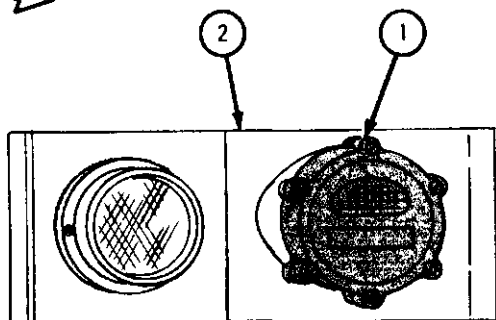
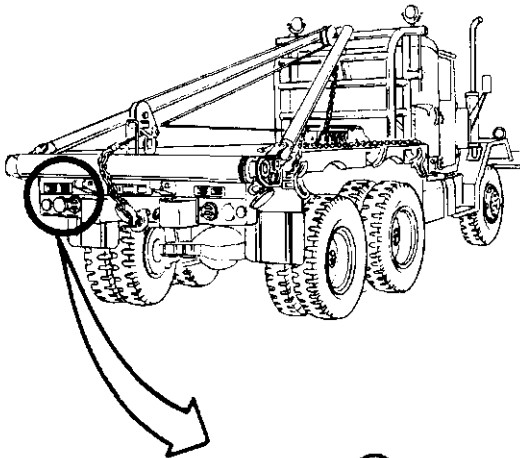

FRONT VIEW

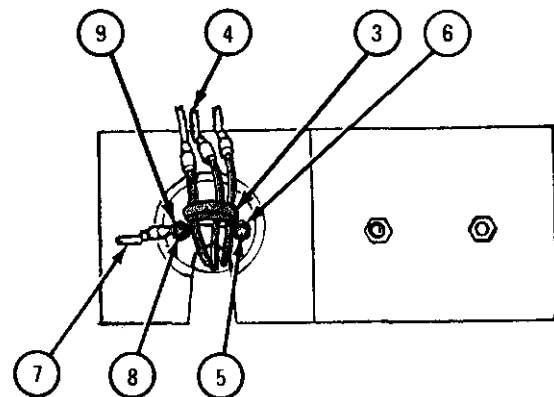

REAR VIEW

TA 046696

7-29. TAILLIGHT AND STOPLIGHT LAMP (LEFT SIDE ONLY) REMOVAL AND REPLACEMENT.

TOOLS: Flat-tip screwdriver

SUPPLIES: None

PERSONNEL: One

EQUIPMENT CONDITION: Truck parked, engine off, handbrake set.

a. Removal.

FRAME 1

NOTE

Screws (1) do not come all the way out of light door.

1. Using screwdriver, unscrew and take off six screws (1). Take off light door with gasket (2).
2. Take out lamps (3) by pushing them in and turning them to left.

END OF TASK

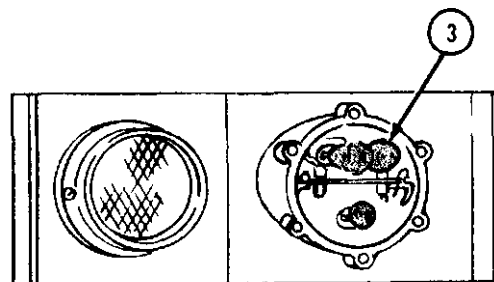
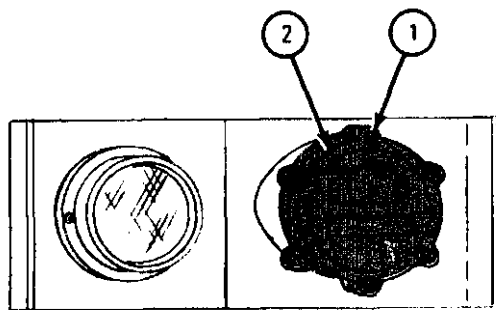
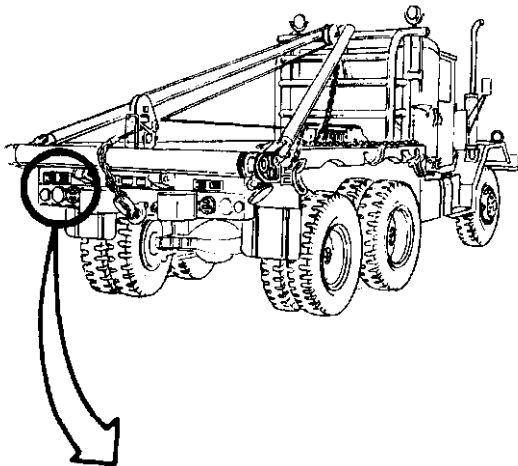

TA 046697

b. Replacement.

FRAME 1

1. Push lamps (1) into sockets (2) and turn to right.
2. Place gasket (3) into groove on light door (4).
3. Put light door (4) on light assembly (5).
4. Using screwdriver, screw in and tighten six screws (6).

END OF TASK

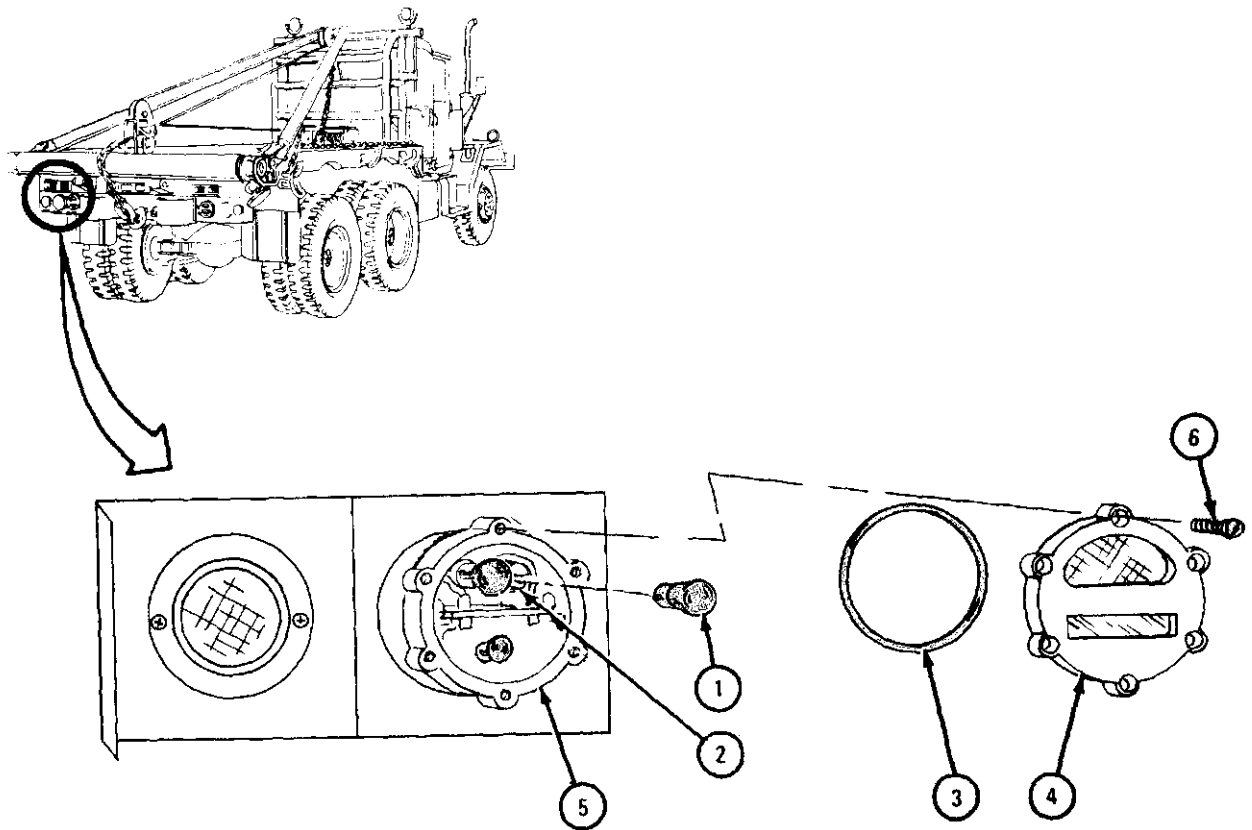

TA 046698

7-30. TAILLIGHT AND STOPLIGHT ASSEMBLY (LEFT SIDE ONLY) REPAIR.

TOOLS: Flat-tip screwdriver
Cross-tip screwdriver (Phillips type)

SUPPLIES: Mild soap
Contact cleaner, MS 230

PERSONNEL: One

EQUIPMENT CONDITION: Truck parked, engine off, handbrake set.

a. Preliminary Procedures.

- (1) Remove left taillight and stoplight assembly. Refer to para 7-28.
- (2) Remove left taillight and stoplight lamps. Refer to para 7-29.

b. Disassembly.

FRAME 1

NOTE

On some taillight and stoplight assemblies, you will have to use a flat-tip screwdriver to take out screws (1 and 2).

1. Using phillips screwdriver, unscrew and take out two screws (1) and two washers (3).
2. Using phillips screwdriver, unscrew and take out three screws (2).
3. Take socket assembly with wiring (4) from light housing (5).

END OF TASK

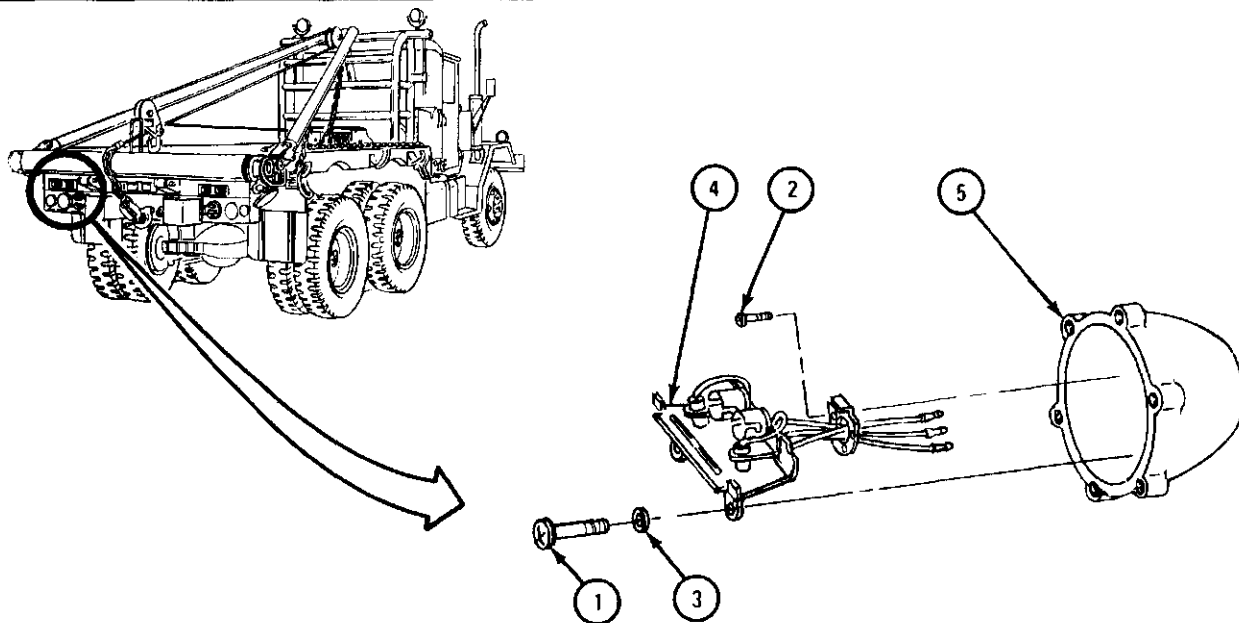

TA 046699

c. Cleaning, Inspection, and Repair.

FRAME 1

1. Using water and mild soap, clean light door and lens (1).
2. Check that light door and lens (1) have no cracks, dents or other damage.
3. Clean all contacts with contact cleaner.
4. Check that gasket (2) has no cracks, nicks or breaks.
5. Check that lamps (3) have no burned out filaments or corroded contacts.
6. Check that socket assembly with wiring (4) has no corroded contacts or broken or damaged wires and insulation.
7. Check that grommet (5) has no cracks or breaks.
8. Check that light housing (6) has no dents, cracks, stripped threads or other damage.
9. Check that all screws have no stripped or damaged threads.
10. Throw away all damaged parts and get new parts in their place.

END OF TASK

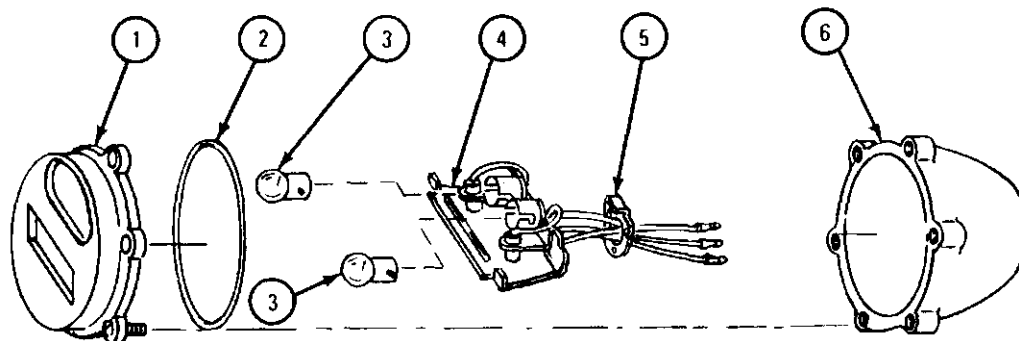

TA 083400

d. Assembly.

FRAME 1

NOTE

On some taillight and stoplight assemblies, you will have to use a flat-tip screwdriver to put in screws (1 and 2).

1. Put grommet (3) in light housing (4).
2. Using phillips screwdriver, screw in and tighten three screws (1).
3. Put socket assembly with wiring (5) on guides in light housing (4), alining mounting holes.
4. Using phillips screwdriver, screw in and tighten two screws (2) and two washers (6).

NOTE

Follow-on Maintenance Action Required:

1. Replace left taillight and stoplight lamps. Refer to para 7-29.
2. Replace left taillight and stoplight assembly. Refer to para 7-28.

END OF TASK

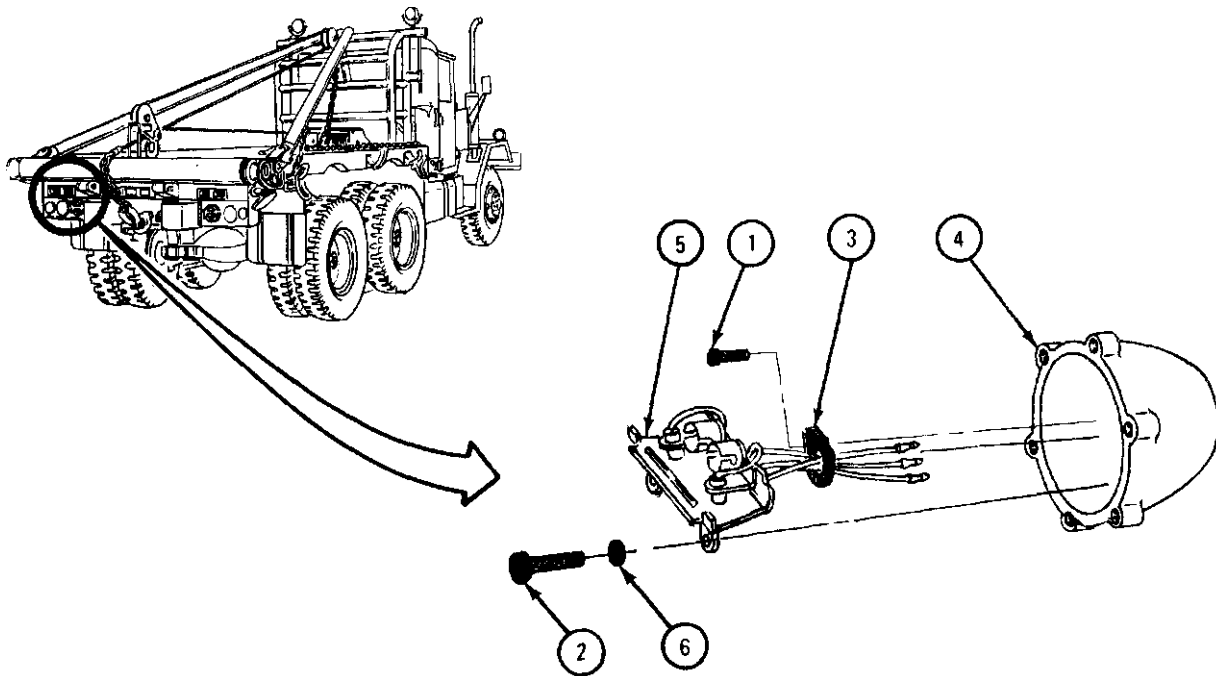

TA 046700

7-31. BLACKOUT STOPLIGHT ASSEMBLY (RIGHT SIDE ONLY) REMOVAL AND REPLACEMENT (EARLY MODEL TRUCKS WITH TURN SIGNALS).

NOTE

The blackout stoplight is mounted on top of bracket on some trucks and on bottom of bracket on other trucks. This task is for truck M756A2. It can be used for other trucks.

TOOLS: 1/2-inch wrench

SUPPLIES: None

PERSONNEL: One

EQUIPMENT CONDITION: Truck parked, engine off, handbrake set, main light switch in OFF position.

a. Removal.

FRAME 1

1. Working from behind light assembly (1), unplug electrical plug (2).
2. Using 1/2-inch wrench, unscrew and take out capscrew (3) with lockwasher (4). Take off light assembly (1).

END OF TASK

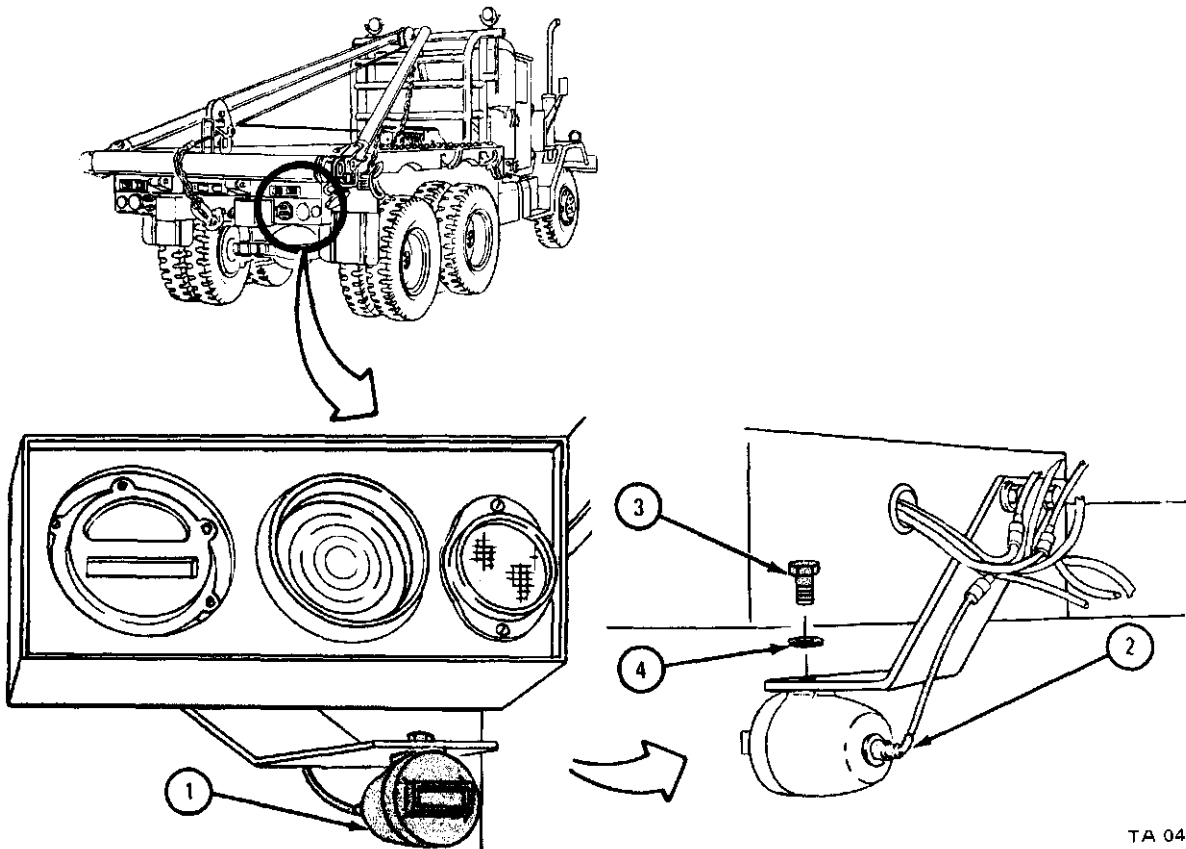

TA 047519

b. Replacement.

FRAME 1

1. Aline hole in light assembly (1) with dowel on bracket (2).
2. Put light assembly (1) on bracket (2).
3. Using 1/2-inch wrench, screw on and tighten capscrew (3) and lockwasher (4).
4. Plug electrical plug (5) into back of light assembly (1).

END OF TASK

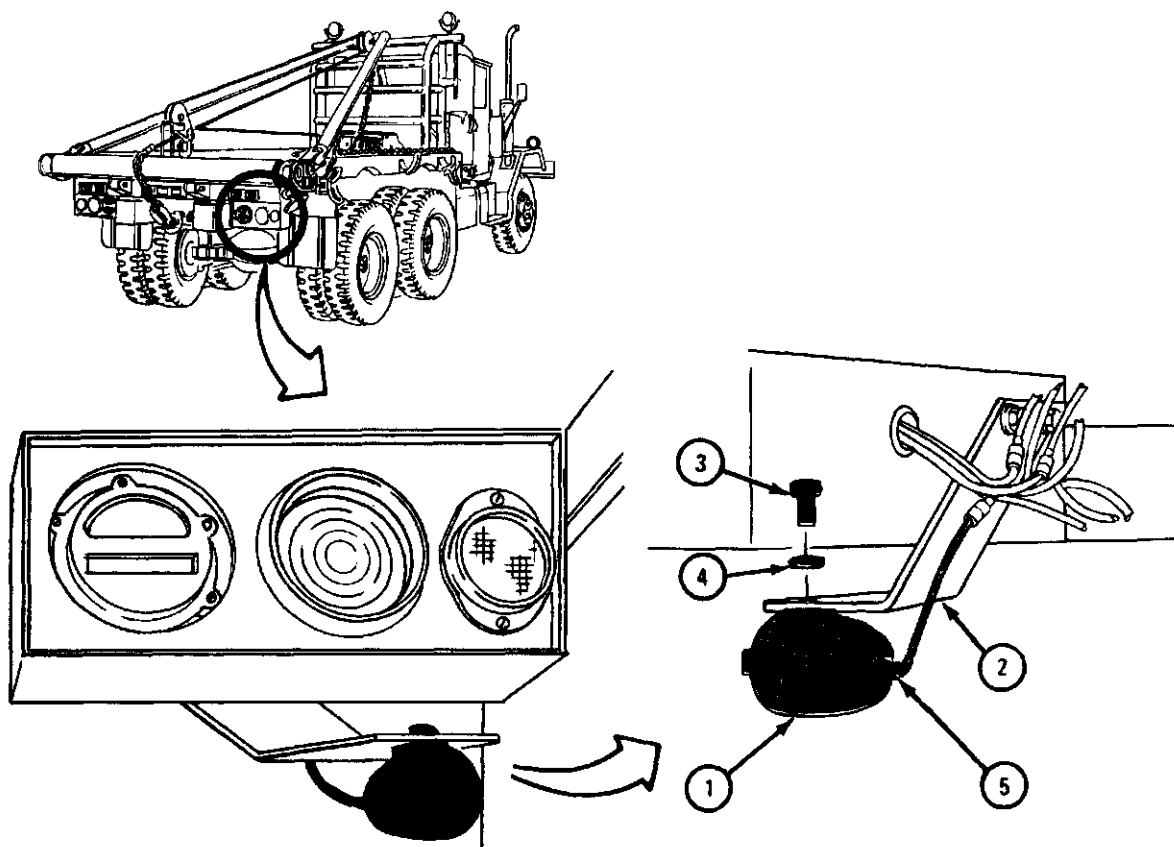

TA 047520

7-32. BLACKOUT STOPLIGHT LAMP (RIGHT SIDE ONLY) REMOVAL AND REPLACEMENT (EARLY MODEL TRUCK WITH TURN SIGNALS).

NOTE

The blackout stoplight is mounted on top of bracket on some trucks and on bottom of bracket on other trucks. This task is for truck M756A2. It can be used for other trucks.

TOOLS: Flat-tip screwdriver

SUPPLIES: None

PERSONNEL: One

EQUIPMENT CONDITION: Truck parked, engine off, handbrake set, main light switch in OFF position.

a. Removal.

FRAME 1

1. Using screwdriver, unscrew and take out two screws (1). Take off light door with lens (2).
2. Push in lamp (3), turn it to left, and take out lamp.

END OF TASK

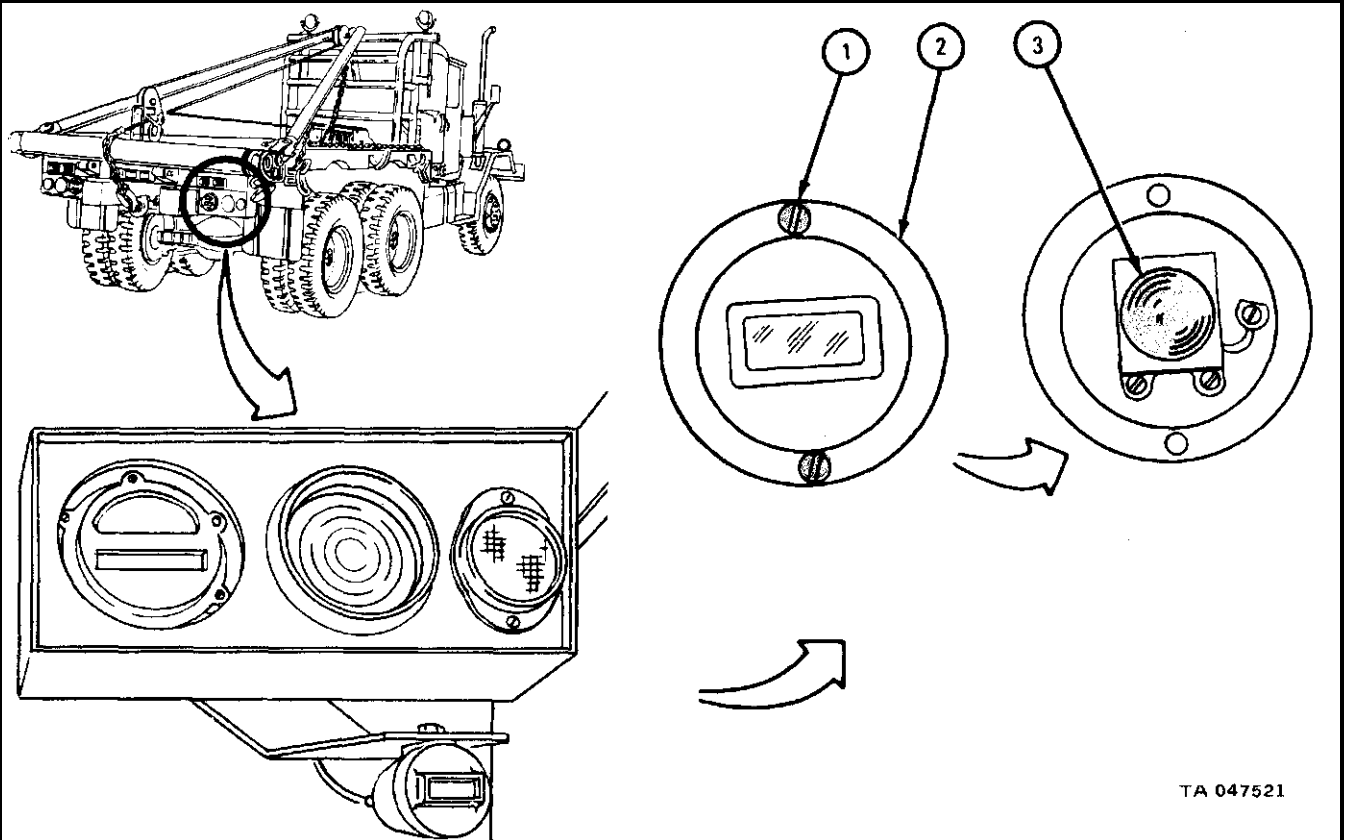

TA 047521

b. Replacement.

FRAME 1

1. Put lamp (1) into lamp socket (2) by pushing it in and turning it to right.
2. Put light door with lens (3) on light housing (4).
3. Using screwdriver, screw in and tighten two screws (5).

END OF TASK

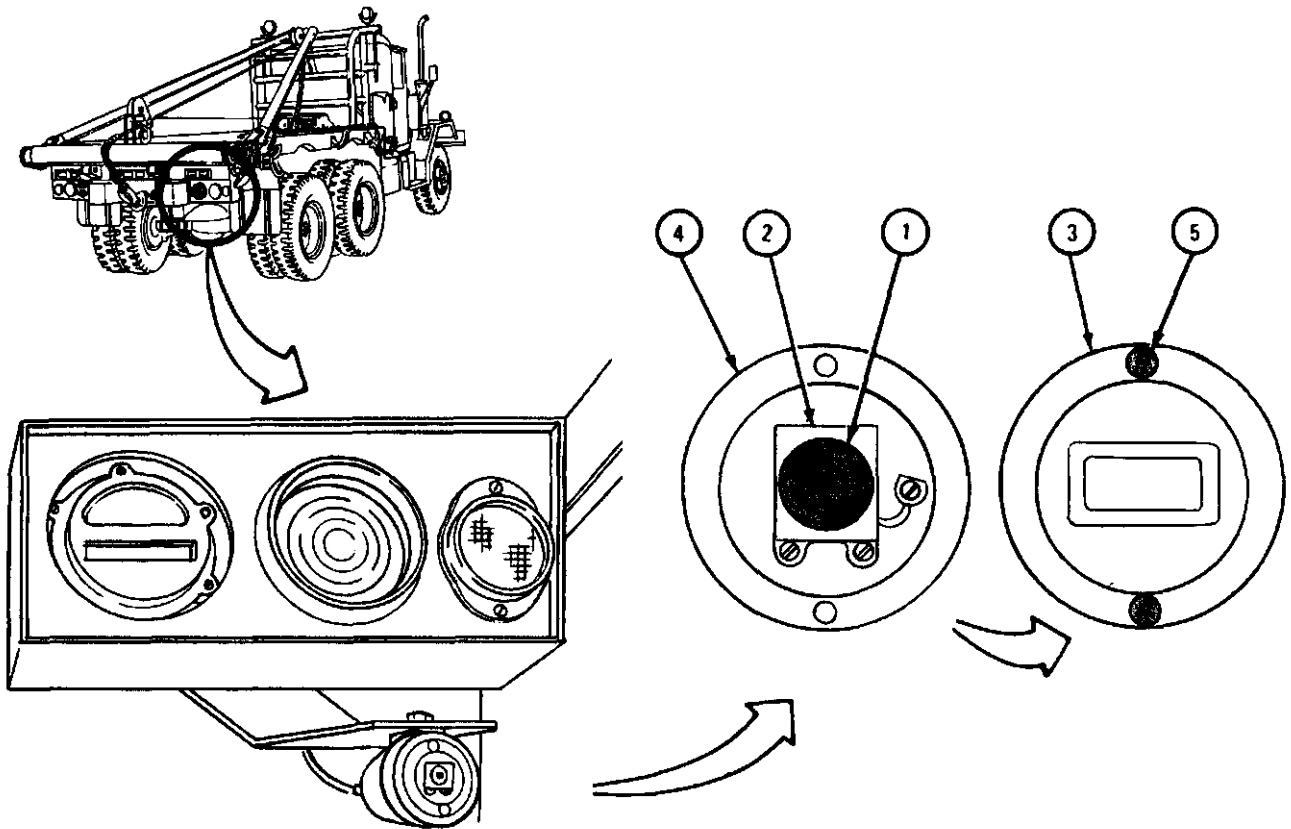

TA 047522

7-33. BLACKOUT STOPLIGHT ASSEMBLY (RIGHT SIDE ONLY) REPAIR.

TOOLS: Flat-tip screwdriver

SUPPLIES: None

PERSONNEL: One

EQUIPMENT CONDITION: Truck parked, engine off, handbrake set, main light switch in OFF position.

- a. Preliminary Procedure. Remove blackout stoplight lamp. Refer to para 7-32.
- b. Disassemble.

NOTE

On some trucks the blackout stoplight is on top of mounting bracket and on others it is under mounting brackets.

FRAME 1

1. Using screwdriver, unscrew and take out two screws (1). Take ground wire (2) off one screw.
2. Take lamp socket and wire assembly (3) out of light housing (4).
3. Pull positive lead (5) out of plug (6).

END OF TASK

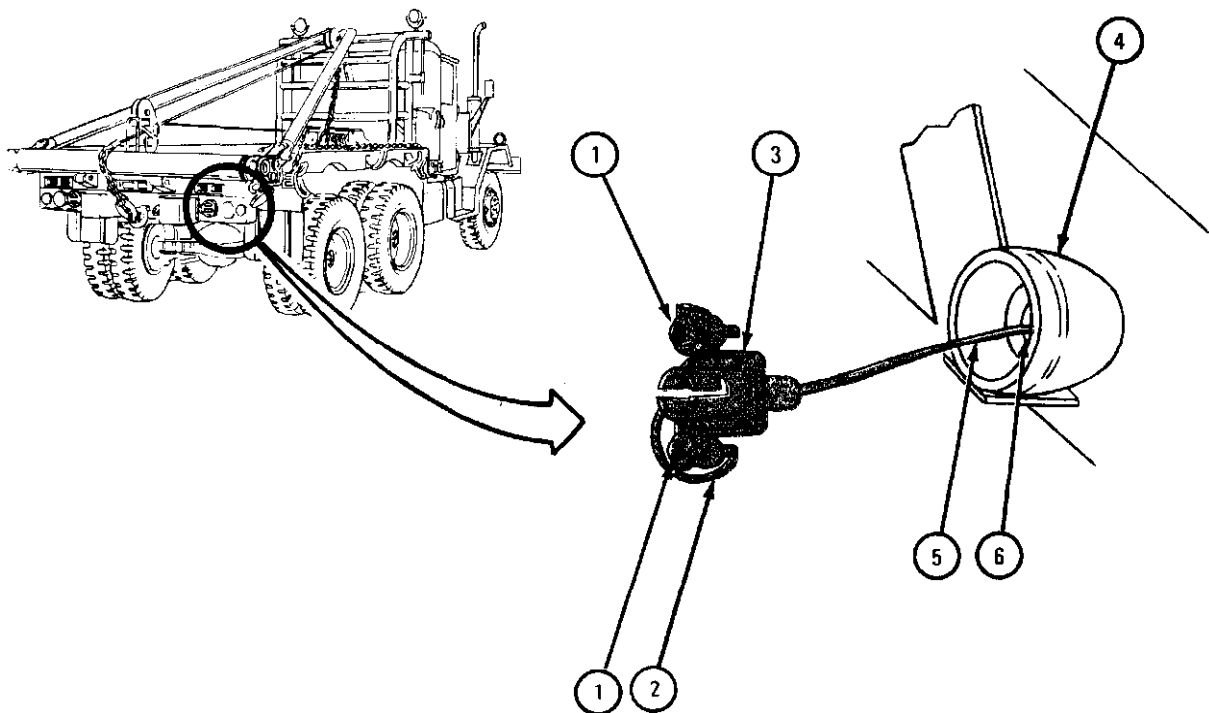

TA 047523

c. Repair. Check that all parts are not damaged. Throw away damaged parts and get new ones in their place.

d. Assembly.

FRAME 1

1. Put ground wire (1) on screw (2) as shown.
2. Plug in positive lead (3) to plug (4).
3. Aline holes in lamp socket and wire assembly (5) with holes in light housing (6).
4. Using screwdriver, screw in and tighten screws (2 and 7).

NOTE

Follow-on Maintenance Action Required:

Replace blackout stoplight lamp. Refer to para 7-32.

END OF TASK

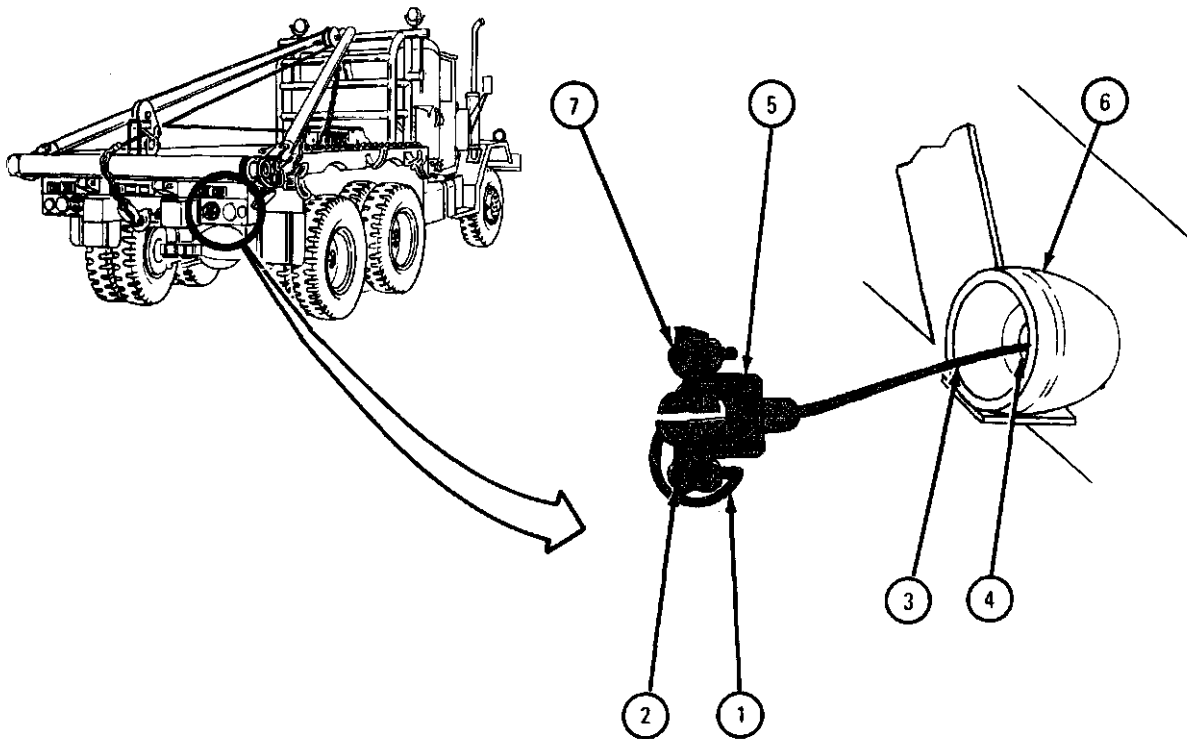

TA 047524

7-34. FRONT MARKER LIGHT AND BRACKET ASSEMBLY REMOVAL AND REPLACEMENT.

TOOLS: 1/2-inch wrench (2)
 9/16-inch wrench

SUPPLIES: None

PERSONNEL: One

EQUIPMENT CONDITION: Truck parked, engine off, handbrake set.

a. Removal.

FRAME 1

- Using 1/2-inch wrenches, unscrew and take off four capscrews (1) and four nuts (2). Take down protector box (3) and let it hang.

NOTE

Tag wires so they will be put back in the same place.

- Unplug three plugs (4) from connectors (5). Take off light assembly (6).

GO TO FRAME 2

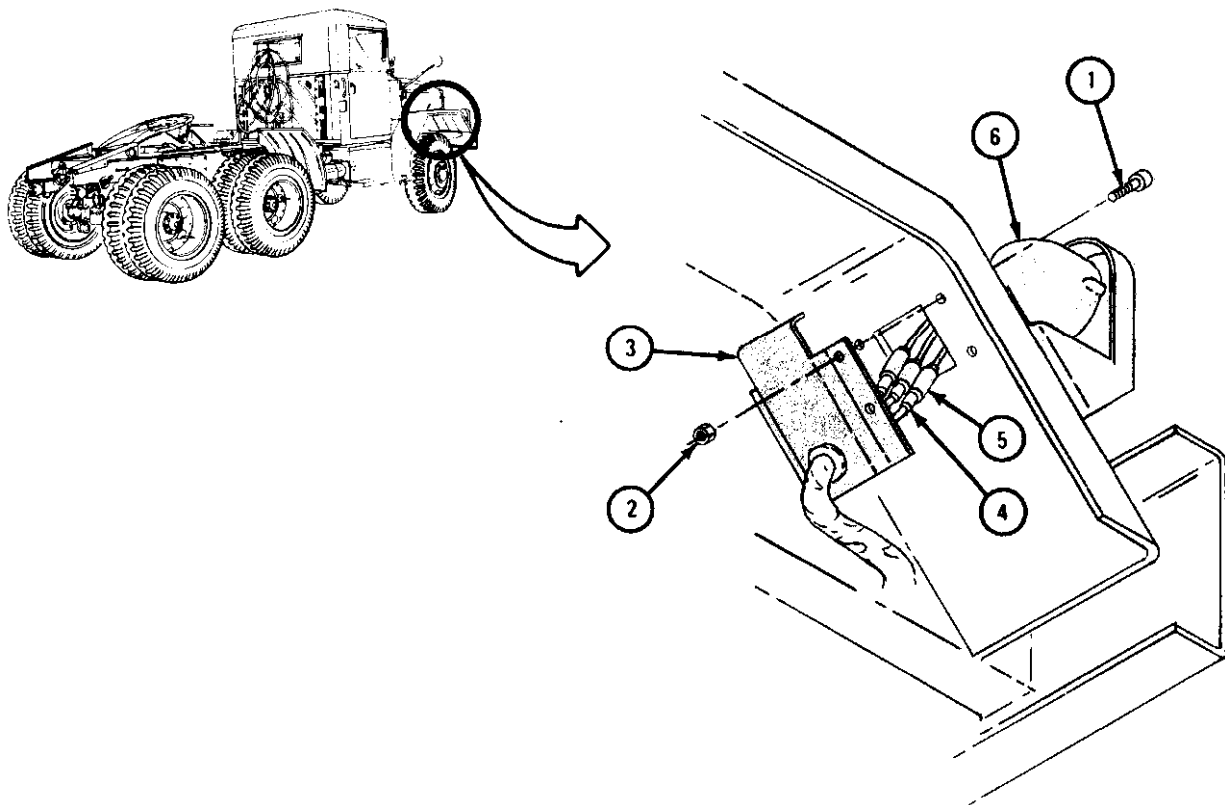

TA 046648

FRAME 2

1. Using 9/16-inch wrench, unscrew and take off two cap screws (1) and lock-washers (2). Take light assembly (3) out of bracket (4).

END OF TASK

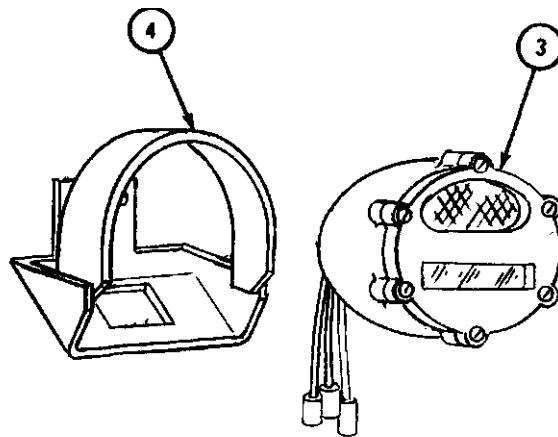
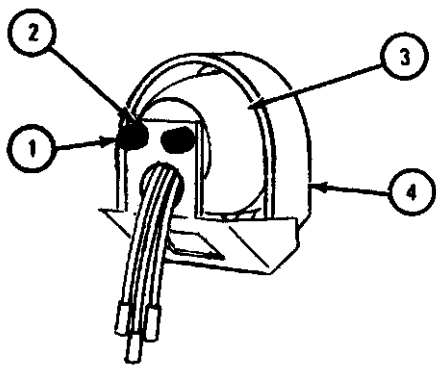

TA 046688

b. Replacement.**FRAME 1**

1. Put three wires (1) through hole in bracket (2).
2. Aline two screw holes in light assembly (3) with two screw holes in bracket (2).
3. Using 9/16-inch wrench, screw in and tighten two capscrews (4) and two lockwashers (5).

GO TO FRAME 2

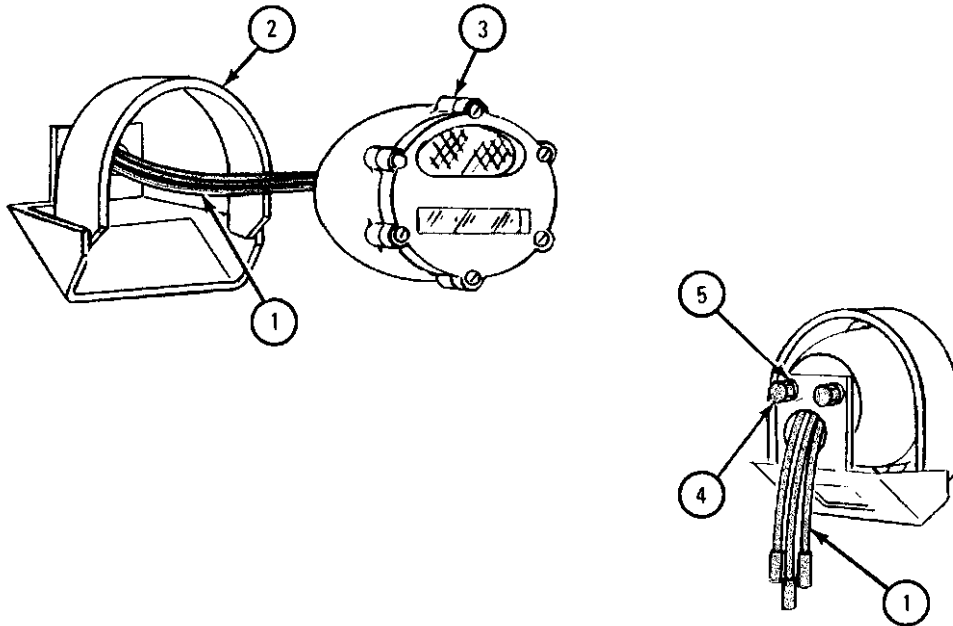

TA 046689

FRAME 2

1. Put wires (1) through hole in fender (2).
2. Aline four screw holes in bracket (3) with four holes in fender (2) and put in four capscrews (4).

GO TO FRAME 3

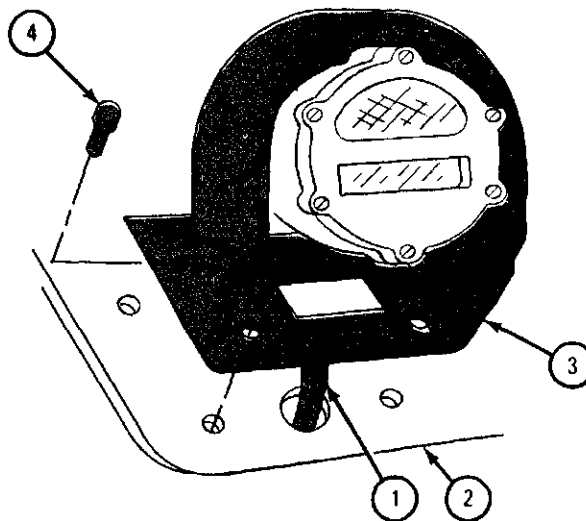
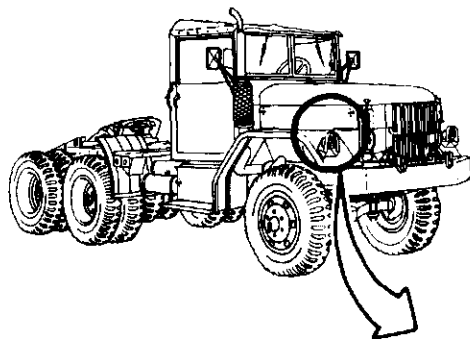

TA 046690

FRAME 3

1. Join three plugs (1) to connectors (2) as tagged. Take off tags.
 2. Put protector box (3) on four screws (4).
 3. Using 1/2-inch wrenches, screw on and tighten four locknuts (5).
- END OF TASK

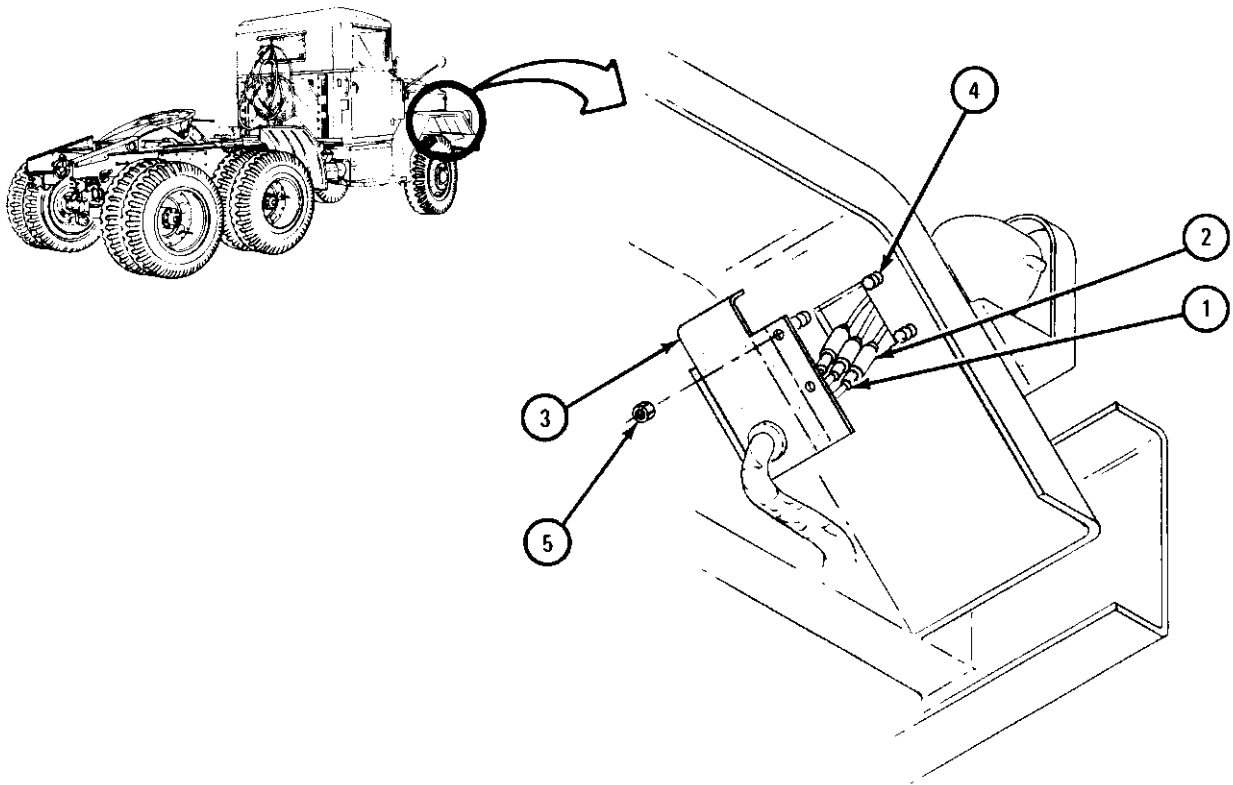

TA 046652

7-35. FRONT MARKER LAMPS REMOVAL AND REPLACEMENT.

TOOLS: Flat-tip screwdriver

SUPPLIES: None

PERSONNEL: One

EQUIPMENT CONDITION: Truck parked, engine off, handbrake set.

a. Removal.

FRAME 1

1. Using screwdriver, unscrew six screws (1) in light door (2). Takeoff light door and gasket (3).
2. Take out three lamps (4) by pushing them in and turning them 1/4 turn to left.

END OF TASK

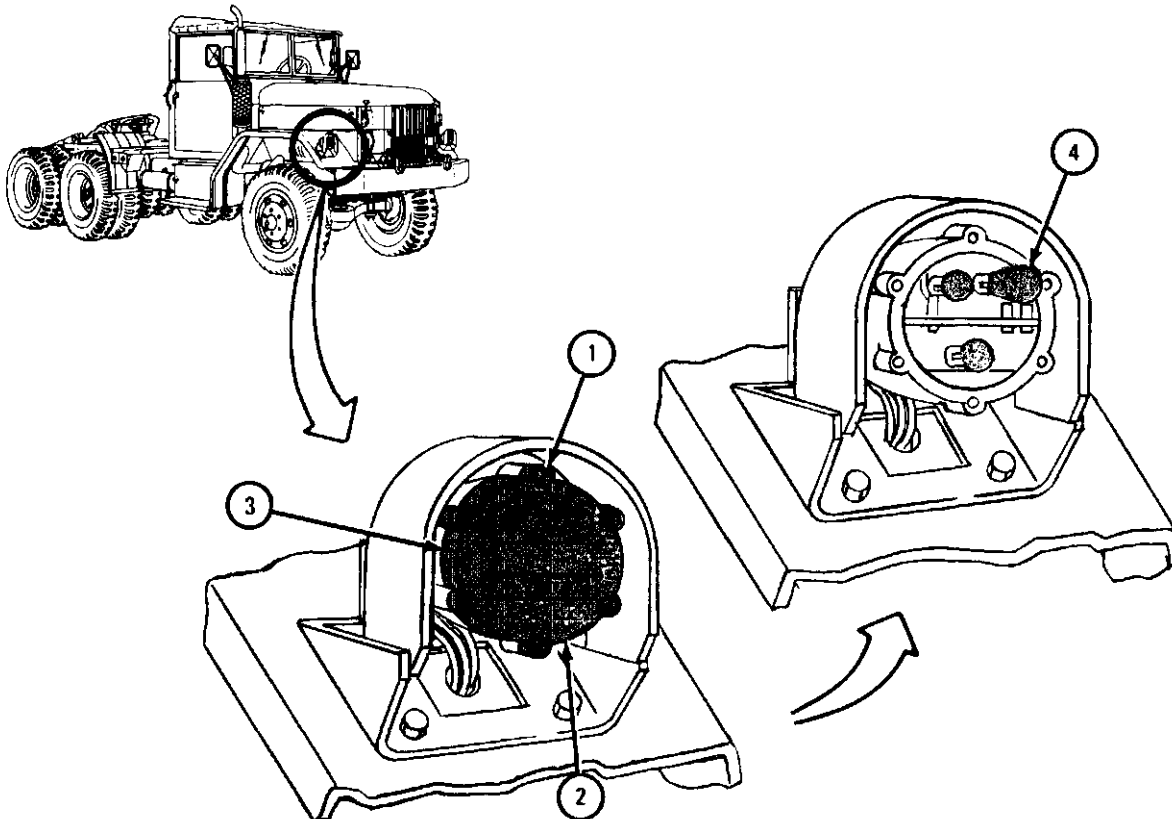

TA 046691

b. Replacement.

FRAME 1

1. Put three lamps (1) into sockets (2) and turn them 1/4 turn to right.
2. Place gasket (3) into groove on light door (4).
3. Put light door (4) on light assembly (5).
4. Using screwdriver, screw in and tighten six screws (6).

END OF TASK

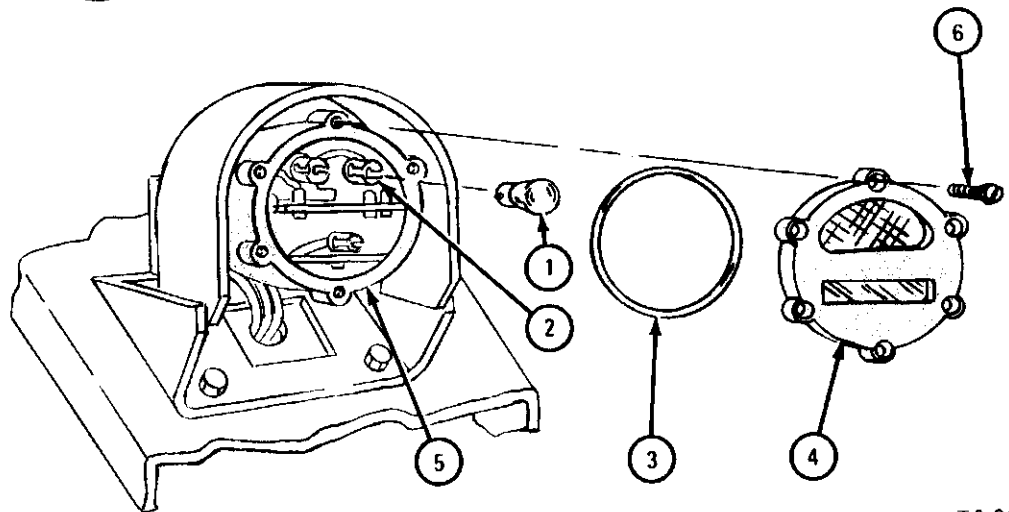
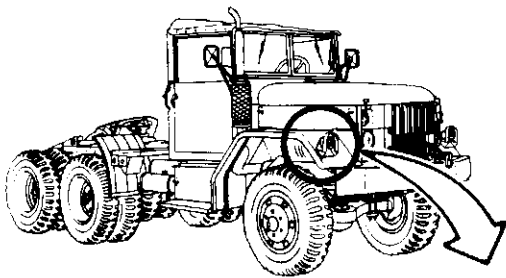

TA 046692

7-36. FRONT MARKER LIGHT REPAIR.

TOOLS: Cross-tip screwdriver (Phillips type)

SUPPLIES: Mild soap
Electrical contact cleaner, MS 230

PERSONNEL: One

EQUIPMENT CONDITION: Truck parked, engine off, handbrake set.

a. Preliminary Procedures.

(1) Remove front marker light assembly. Refer to para 7-34.

(2) Remove front marker lamps. Refer to para 7-35.

b. Disassembly.

FRAME 1

1. Using screwdriver, unscrew and take out two screws (1) and two washers (2).
2. Using screwdriver, unscrew and take out three screws (3).
3. Take out socket assembly with wiring (4). Take out grommet (5) from light housing (6).

END OF TASK

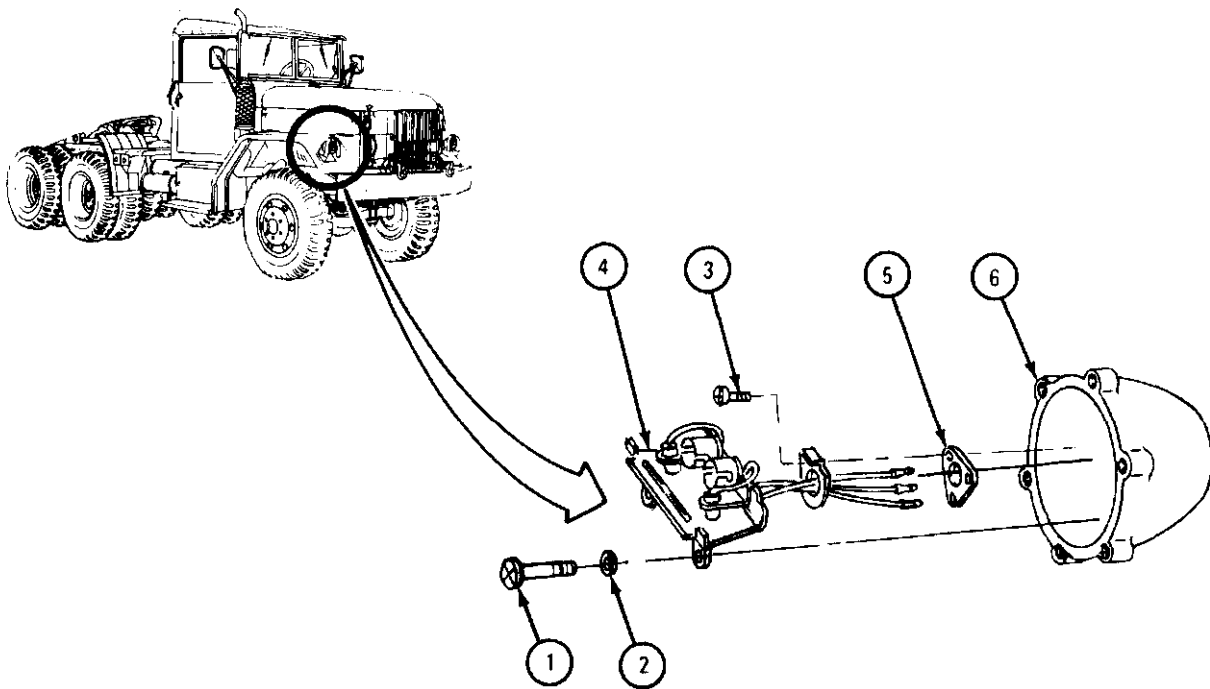

TA 046693

c. Cleaning, Inspection, and Repair.**FRAME 1**

1. Using water and mild soap, clean light door (1) and lens.
2. Check light door (1) and lens for cracks, dents or other damage.
3. Clean all other parts using electrical contact cleaner.
4. Check gasket (2) for cracks, nicks or breaks.
5. Check lamps (3) for burned out filaments or corroded contacts.
6. Check socket assembly (4) for corroded contacts or broken or damaged wires and insulation.
7. Check grommet (5) for cracks or breaks.
8. Check light housing (6) for dents, cracks, stripped threads or other damage.
9. Check all screws for stripped or damaged threads.
10. Throw away all damaged parts and get new parts in their place.

END OF TASK

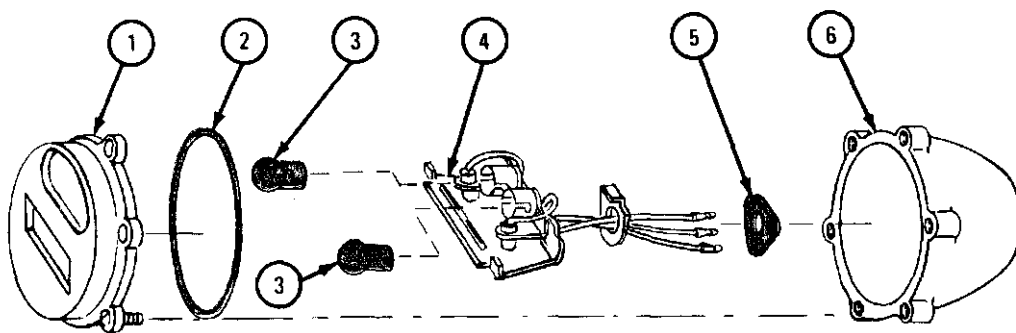

TA 047504

d. Assembly.

FRAME 1

1. Put grommet (1) in light housing (2). Using screwdriver, screw in and tighten three screws (3).
2. Put socket assembly with wiring (4) into light housing (2) and pull wires through holes in grommet (1).
3. Using screwdriver, screw in and tighten two screws (5) and two washers (6).

NOTE

Follow-on Maintenance Action Required:

1. Replace front marker lamps. Refer to para 7-35.
2. Replace front marker light assembly. Refer to para 7-34.

END OF TASK

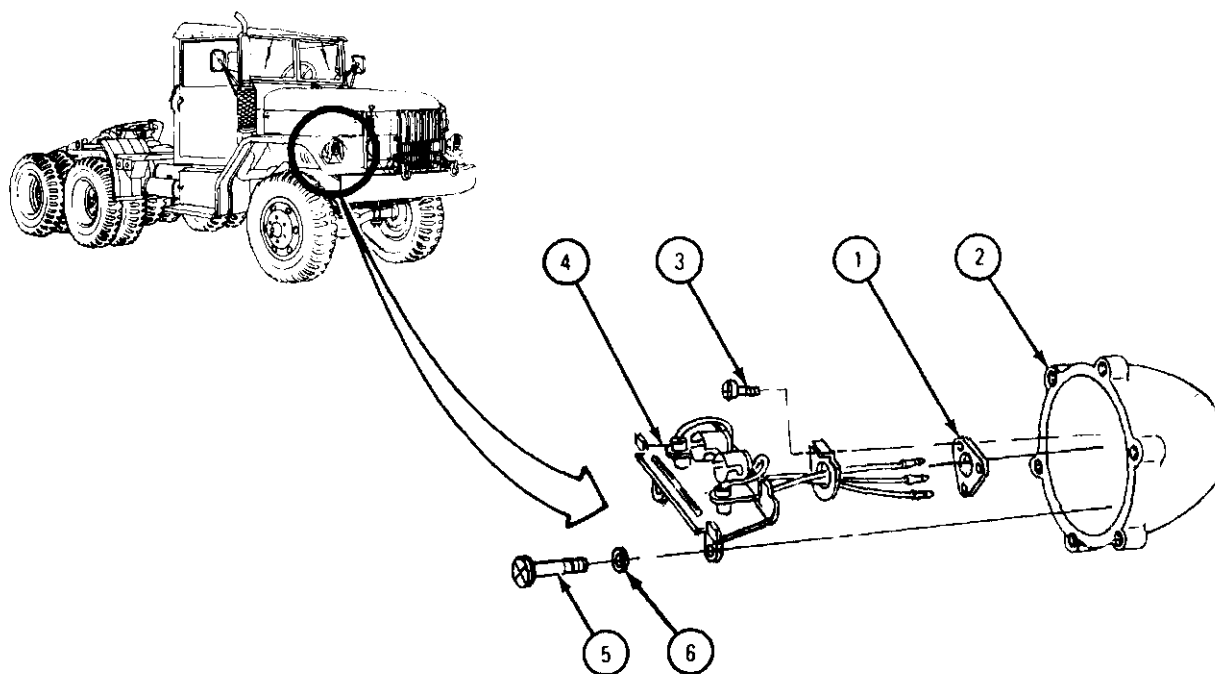

TA 046694

7-37. FLOODLIGHT AND BRACKET ASSEMBLY REMOVAL, REPAIR, AND REPLACEMENT (TRUCK M756A2).

TOOLS: 15/16-inch wrench (2)

SUPPLIES: Solvent, dry cleaning, type II (SD-2), Fed. Spec P-D-680

PERSONNEL: One

EQUIPMENT CONDITION: Truck parked, engine off, handbrake set, light switch in OFF position.

a. Removal.

FRAME 1

1. Unplug two electrical leads (1) from connectors (2).
 2. Using 15/16-inch wrenches, unscrew and take off two nuts (3) on base of light bracket (4) and take off washer (5).
 3. Take light bracket (4) out of body bracket (6) and take off washer (7).
- END OF TASK

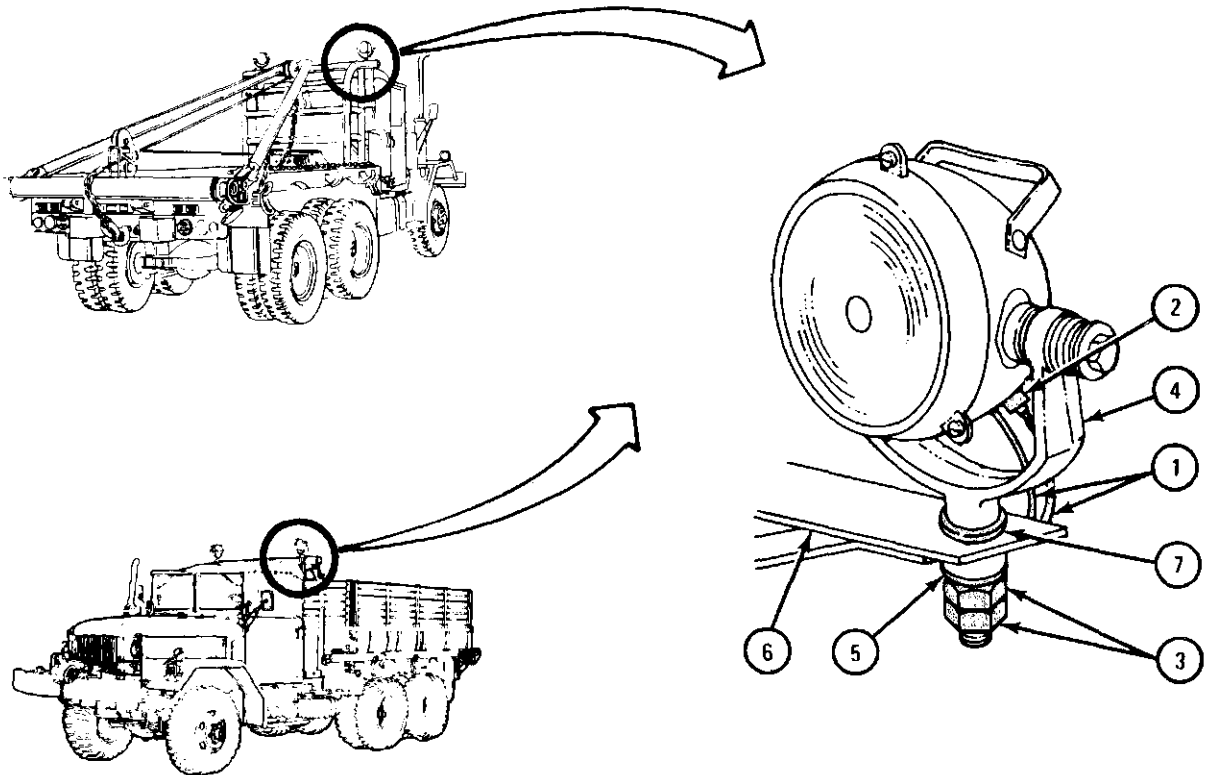

TA 046680

b. Cleaning, Inspection, and Repair.

WARNING

Dry cleaning solvent is flammable. Do not use near an open flame. Keep a fire extinguisher nearby when solvent is used. Use only in well-ventilated places. Failure to do this may result in injury to personnel and damage to equipment.

(1) Using a clean cloth dampened with solvent, clean all parts of floodlight assembly.

(2) Check electrical leads for breaks, frayed insulation, rusty or dirty contacts or other damage.

(3) Check threads on bracket and nuts for damage.

(4) Throw away damaged parts and get new ones in their place.

c. Replacement.

FRAME 1

1. Put washer (1) on light bracket (2). Put light bracket into body bracket (3).
2. Put washer (4) on light bracket (2).
3. Using 15/16-inch wrenches, screw on and tighten nuts (5 and 6).
4. Plug two electrical leads (7) into connectors (8).

END OF TASK

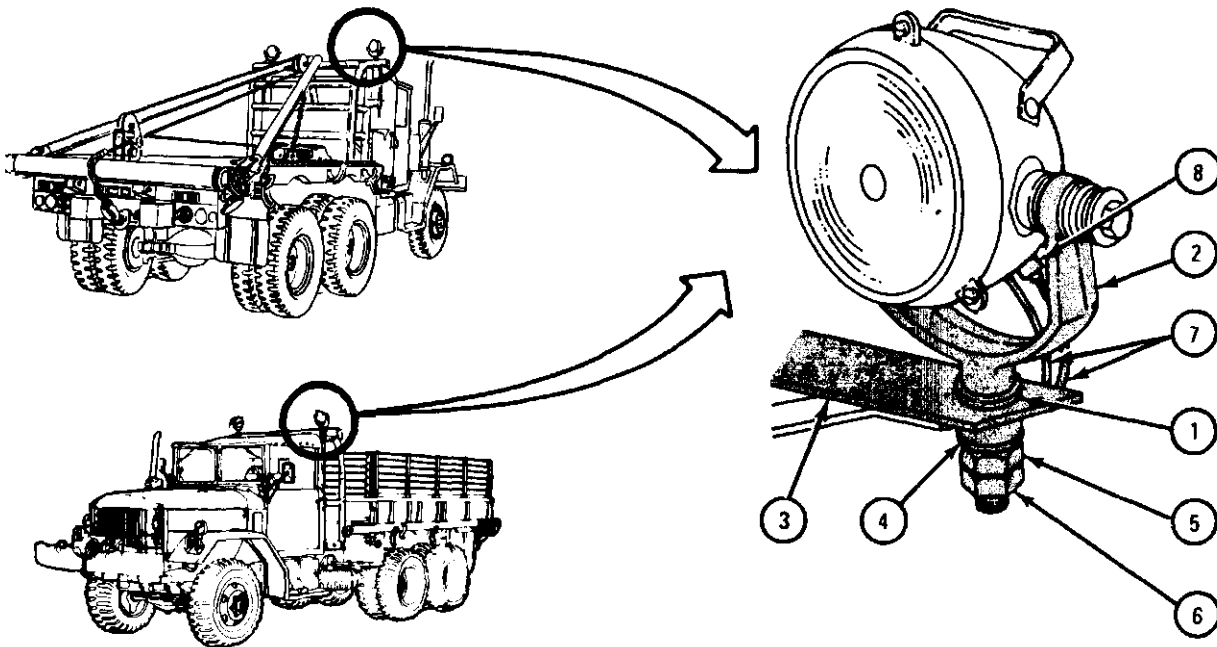

TA 046681

7-38. FLOODLIGHT HOUSING REMOVAL, REPAIR, AND REPLACEMENT (TRUCK M756A2).

TOOLS: 3/4-inch box wrench
 9/16-inch box wrench

SUPPLIES: Solvent, dry cleaning, type II (SD-2) , Fed. Spec P-D-680

PERSONNEL: One

EQUIPMENT CONDITION: Truck parked, engine off, handbrake set.

- a. Preliminary Procedure. Remove floodlight sealed beam. Refer to para 7-39.
- b. Removal.

FRAME 1

1. Using 3/4-inch wrench, hold capscrew (1) and using 9/16-inch wrench, unscrew and take off nut (2), lockwasher (3), and washer (4).
2. Take out capscrew (1) with two spring washers (5), two washers (6), and washer (7).
3. Take out spacer (8) and grommet (9).
4. Do steps 1 through 3 again for other side of housing and take off floodlight housing (10).

END OF TASK

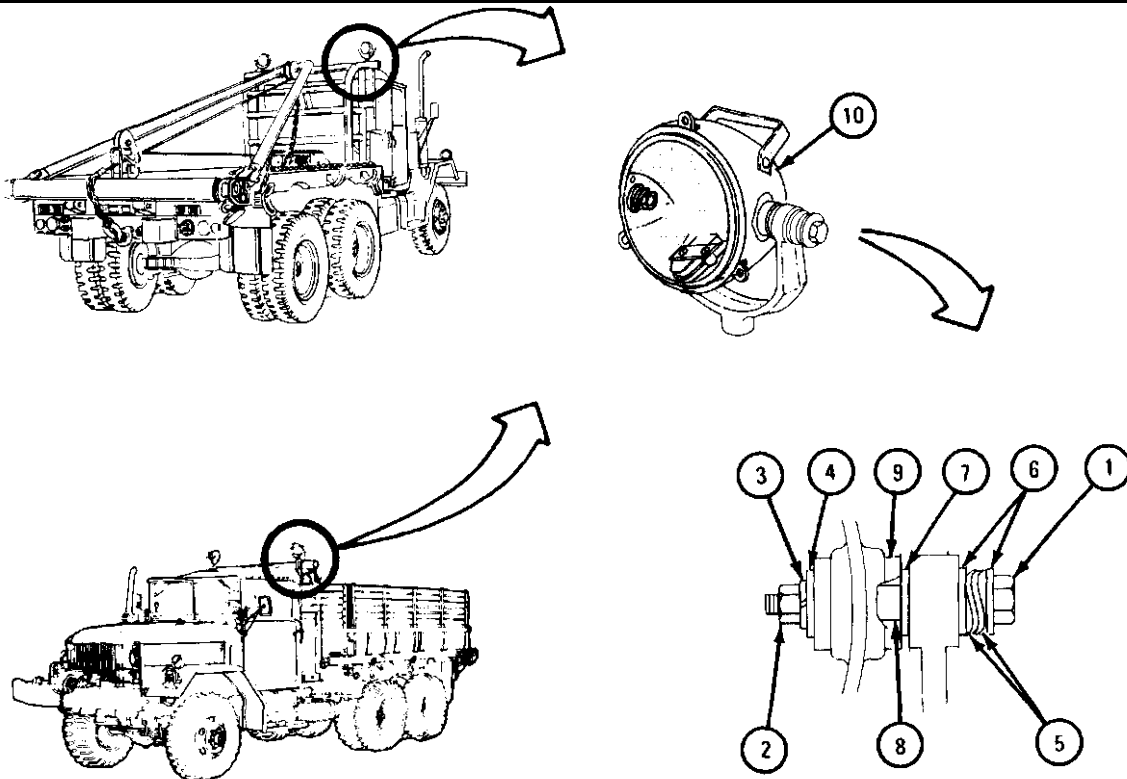

c. Cleaning, Inspection, and Repair.

WARNING

Dry cleaning solvent is flammable. Do not use near an open flame. Keep a fire extinguisher nearby when solvent is used. Use only in well-ventilated places. Failure to do this may result in injury to personnel and damage to equipment.

(1) Using clean cloth dampened with solvent, clean bracket inside and outside of housing. Clean all screws, nuts, and washers by rinsing them in solvent.

(2) Check housing for dents, cracks or other damage. Check screws and nuts for damaged threads.

(3) Throw away damaged parts and get new ones in their place.

d. Replacement.

FRAME 1

1. Put grommet (1) in light housing (2). Put spacer (3) inside grommet.
2. Put flat washer (4), two spring washers (5), and flat washer (6) on capscrew (7). Put capscrew through bracket (8) only.
3. Put washer (9) on capscrew (7). Push capscrew through light housing (2).
4. Put nut with washer and lockwasher (10) on capscrew (7).
5. Using 3/4-inch wrench, hold capscrew (7). Using 9/16-inch wrench, screw on and tighten nut (10).
6. Do steps 1 through 4 again for other side of light housing (2).

NOTE

Follow-on Maintenance Action Required:

Replace floodlight sealed beam. Refer to para 7-39.

END OF TASK

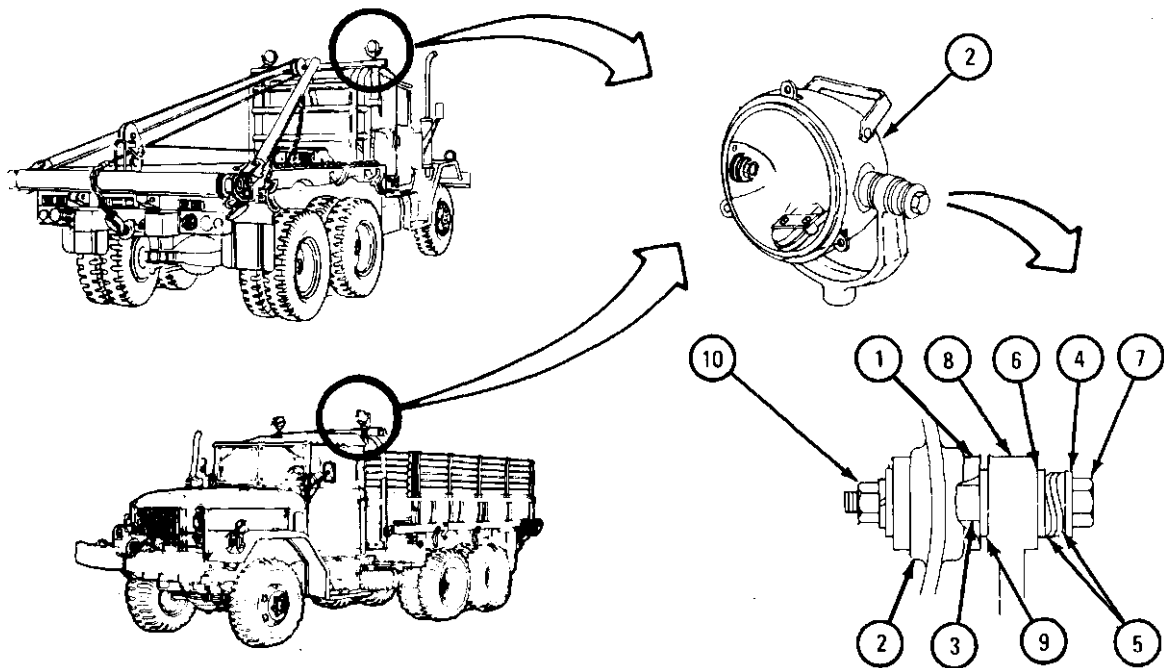

TA 046683

7-39. FLOODLIGHT SEALED BEAM REMOVAL, REPAIR, AND REPLACEMENT.

TOOLS: Flat-tip screwdriver

SUPPLIES: Solvent, dry cleaning, type II (SD-2), Fed. Spec P-D-680
Contact cleaner, MS 230

PERSONNEL: One

EQUIPMENT CONDITION: Truck parked, engine off, handbrake set, light switch in OFF position.

a. Removal.

FRAME 1

1. Using screwdriver, unscrew and take out three screws (1).
2. Pull light door (2) with sealed beam (3) away from light body (4).
3. Using screwdriver, unscrew and take out two screws (6). Take off two electrical leads (5).
4. Take off light door (2) with sealed beam (3).

GO TO FRAME 2

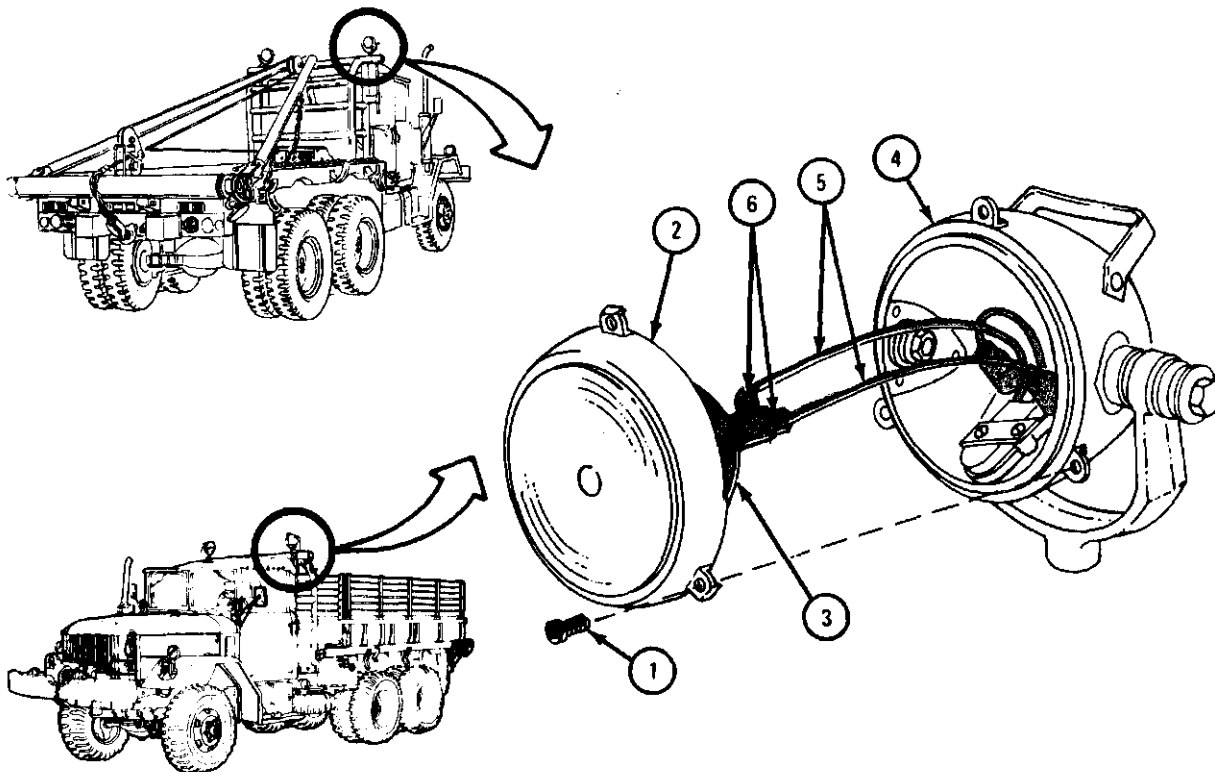

TA 046684

FRAME 2

WARNING

Cover spring with free hand when prying it out. Retaining springs (1) may snap out and cause injury to personnel.

1. Using screwdriver, pry out four retaining springs (1) from light door (2).
2. Take sealed beam (3) out of light door (2).

END OF TASK

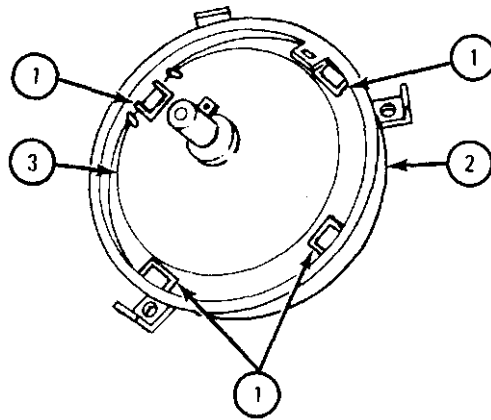

TA 049288

b. Cleaning, Inspection, and Repair.

WARNING

Dry cleaning solvent is flammable. Do not use near an open flame. Keep a fire extinguisher nearby when solvent is used. Use only in well-ventilated places. Failure to do this may result in injury to personnel and damage to equipment.

(1) Using clean rag dampened with solvent, clean light door and sealed beam unit.

(2) Check light door for dents, cracks or other damage. Check sealed beam unit for cracks in glass, burned out filament, and corroded contacts. If contacts are corroded, using cent act cleaner, clean them.

(3) Check screws for damaged threads.

(4) Throw away damaged parts and get new ones in their place.

c. Replacement.

FRAME 1

1. Put sealed beam (1) into light door (2). Aline tab on sealed beam (1) with slot on light door (2).

WARNING

Cover retaining springs (3) with free hand when putting them in. Retaining springs may snap out and cause injury to personnel.

2. Using screwdriver, put in four evenly spaced retaining springs (3). Put square bend of spring over sealed beam (1) and push free ends under flange of light door (2).

GO TO FRAME 2

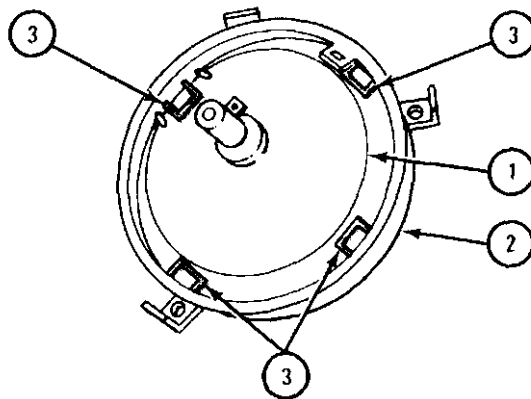

TA 049289

FRAME 2

1. Put two electrical leads (1) on sealed beam terminals (2) as tagged. Using screwdriver, screw in and tighten two screws (3). Take off tags.
2. Put light door (4) with sealed beam (5) on light body (6).
3. Using screwdriver, screw in and tighten three screws (7).

END OF TASK

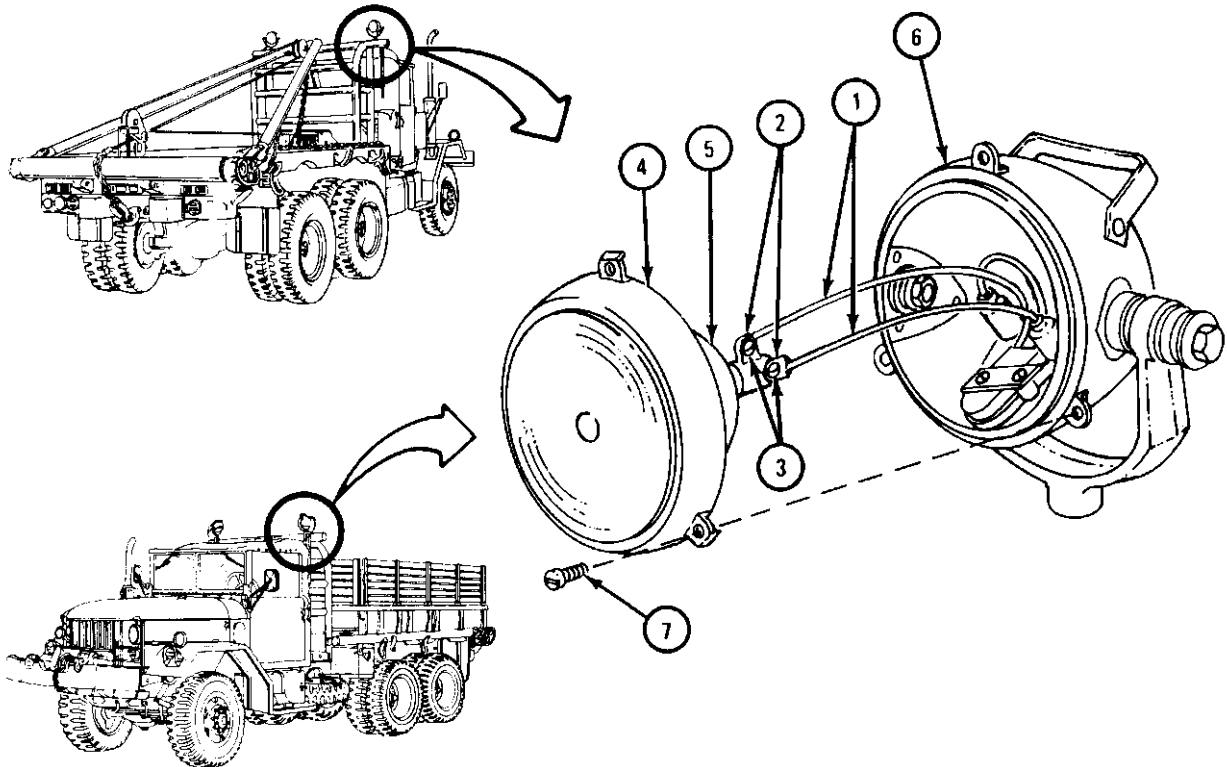

TA 046685

7-40. FRONT COMPOSITE LIGHT AND BRACKET ASSEMBLY REMOVAL AND REPLACEMENT.

TOOLS: 1/2-inch open end wrench (2)
9/16-inch open end wrench
Flat-tip screwdriver

SUPPLIES: Tags

PERSONNEL: One

EQUIPMENT CONDITION: Truck parked, engine off, handbrake set, light switch in OFF position.

a. Removal.

FRAME 1

1. Using 1/2-inch wrenches, unscrew and take out four capscrews (1), four lockwashers (2), and four nuts (3). Take down protector box (4) and let it hang.

NOTE

Tag wires so they will be put back in the same places.

2. Unplug three plugs (5) from connectors (6). Using screwdriver, take out grommet (7). Take off light assembly (8).

GO TO FRAME 2

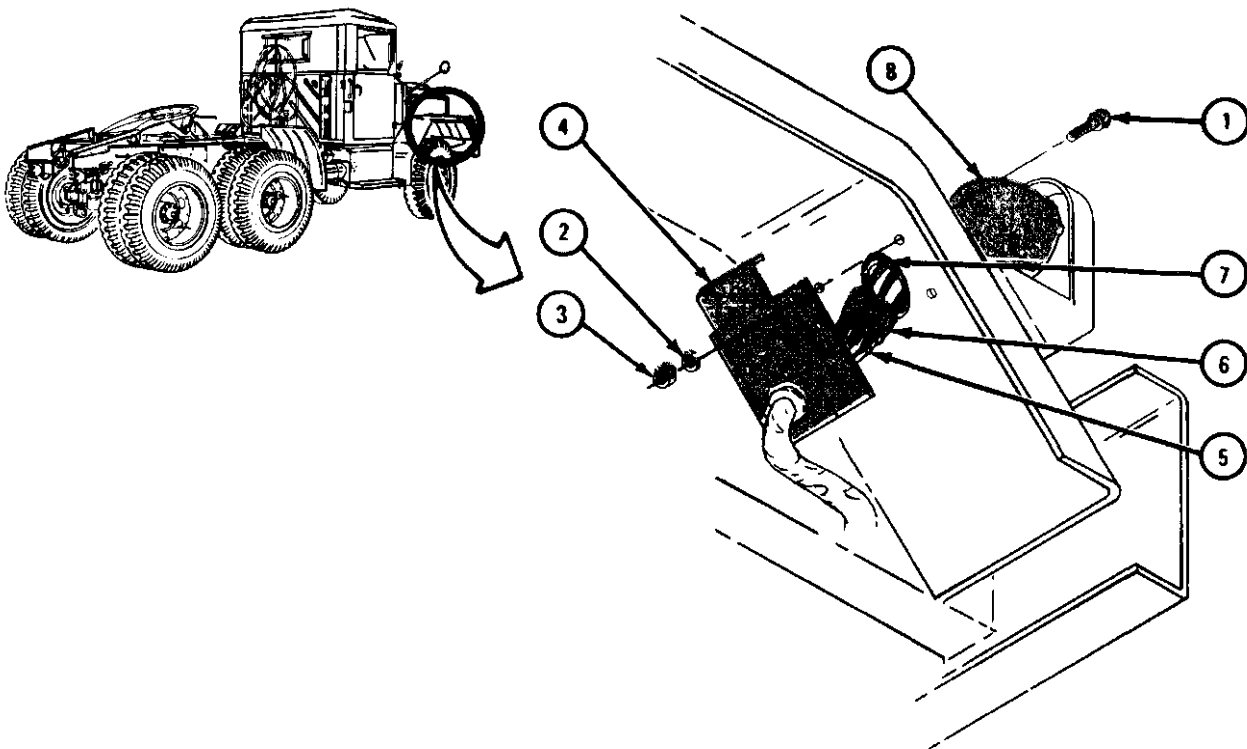

TA 085569

FRAME 2

1. Using 9/16-inch wrench, unscrew and take out two cap screws (1) and lockwashers (2). Take light assembly (3) off bracket (4).

END OF TASK

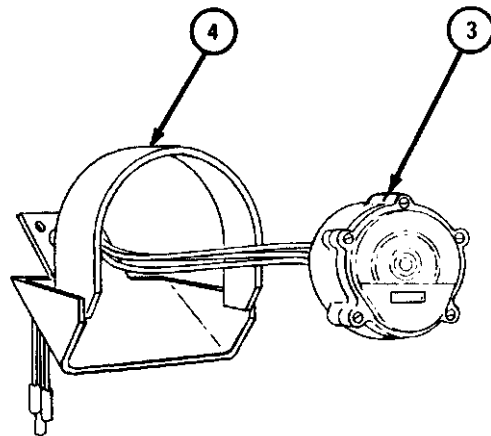
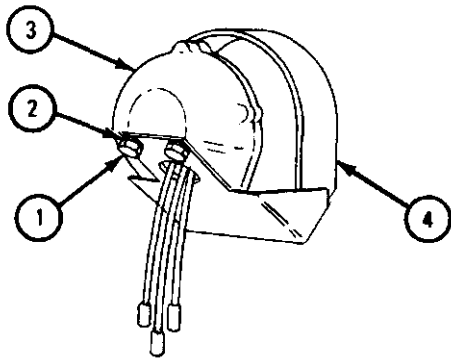

TA 085570

b. Replacement.

FRAME 1

1. Put three wires (1) through hole in bracket (2).
2. Align two screw holes in light assembly (3) with two screw holes in bracket (2).
3. Using 9/16-inch wrench, screw in and tighten two capscrews (4) with lockwashers (5).

GO TO FRAME 2

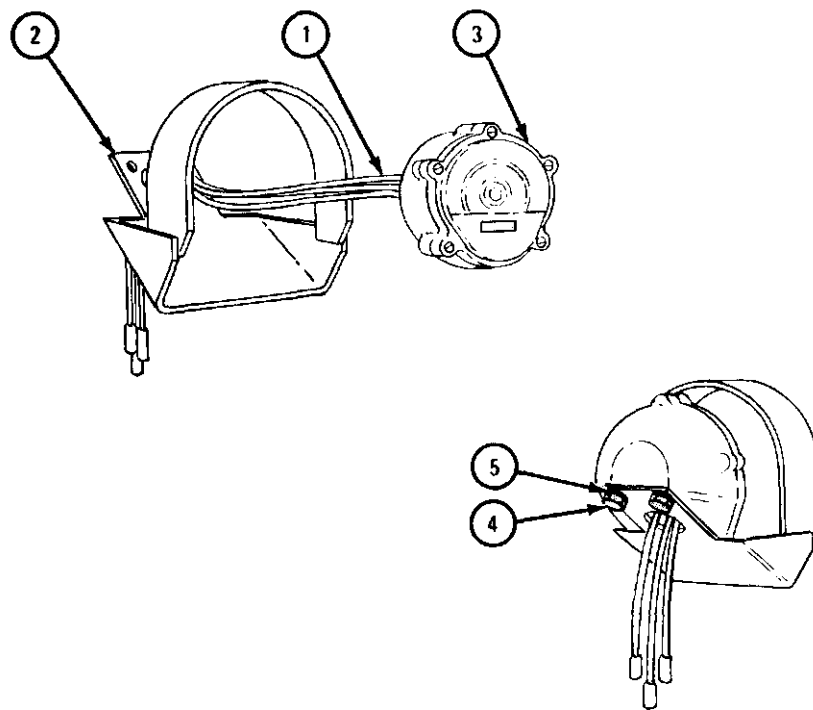

TA 085571

FRAME 2

1. Put three wires (1) through hole in fender (2).
2. Using screwdriver, put rubber grommet (3) in hole in fender (2).
3. Aline four screw holes in bracket (4) with four holes in fender (2) and put in four capscrews (5).

GO TO FRAME 3

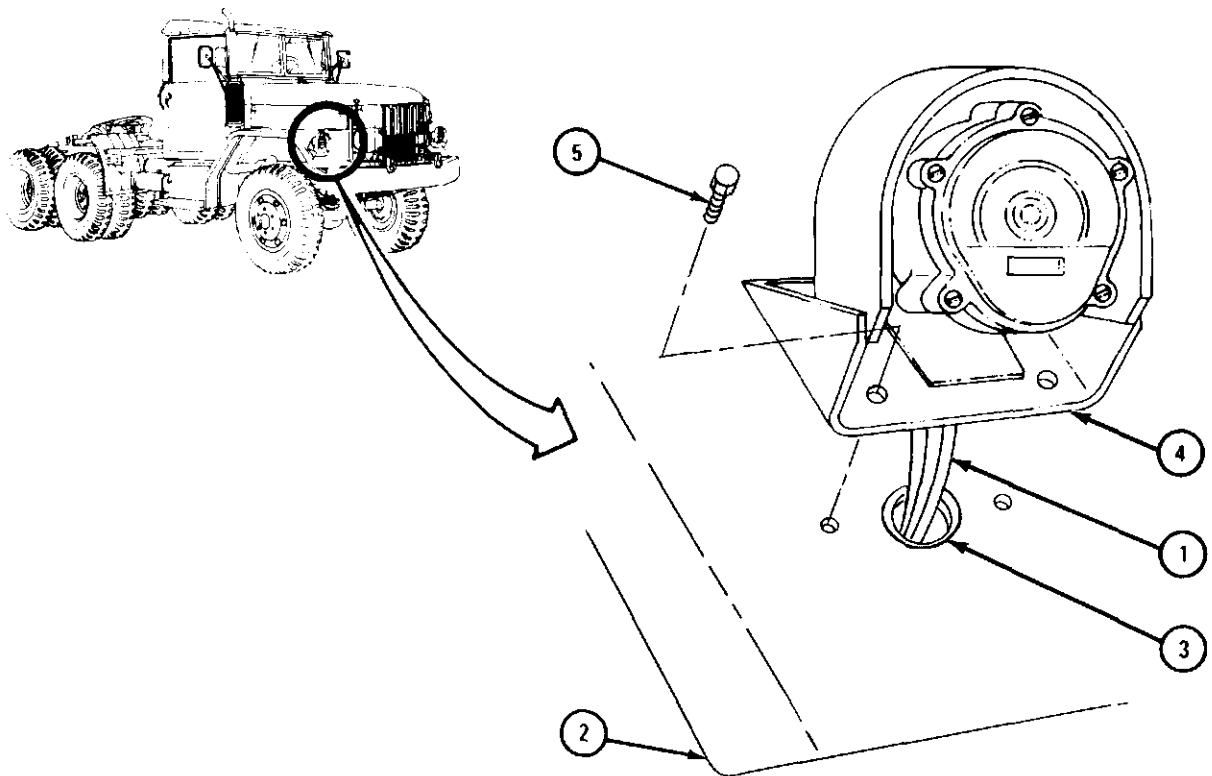

TA 046651

FRAME 3

1. Join three plugs (1) to connectors (2) as tagged. Take off tags.
2. Put protector box (3) on four capscrews (4).
3. Using 1/2-inch wrenches, screw on and tighten four nuts (5) and lockwashers (6).

END OF TASK

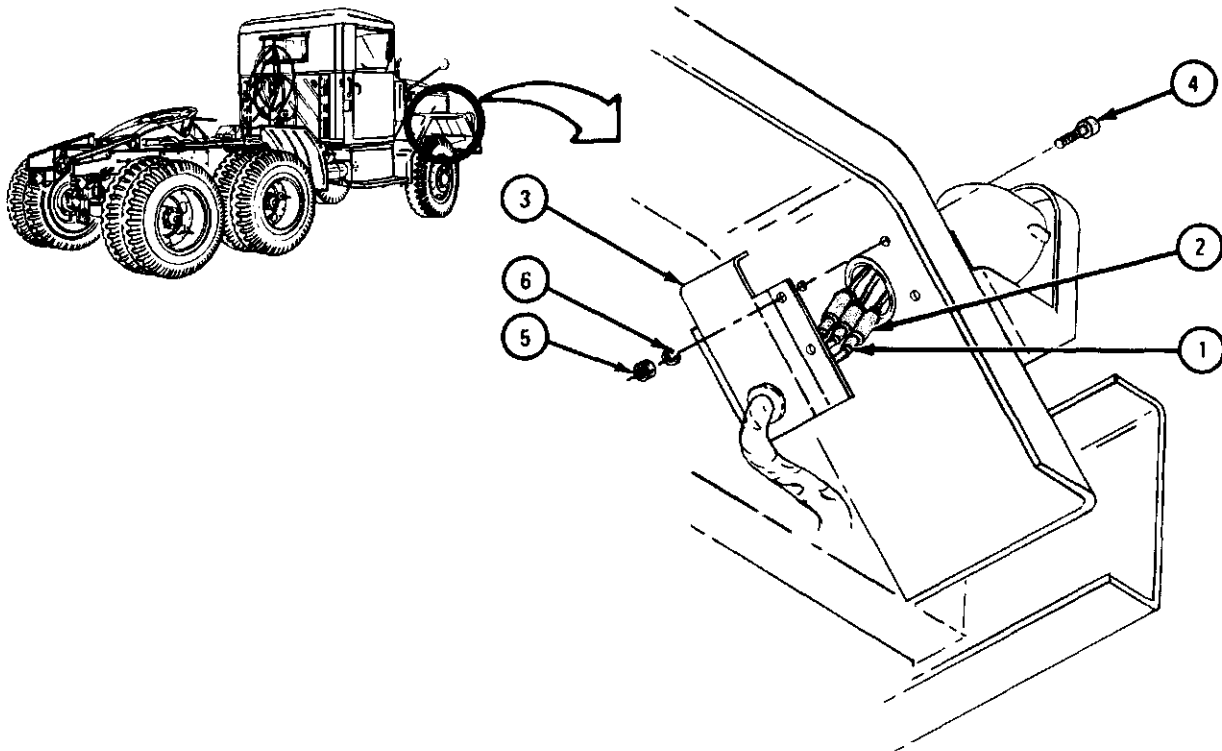

TA 085572

7-41. FRONT COMPOSITE LAMPS REMOVAL AND REPLACEMENT.

TOOLS: Flat-tip screwdriver

SUPPLIES: None

PERSONNEL: One

EQUIPMENT CONDITION: Truck parked, engine off, handbrake set, light switch in OFF position.

a. Removal.

FRAME 1

1. Using screwdriver, unscrew and take out five screws (1) in light door (2). Take off light door and gasket (3).
 2. Take out any of three lamps (4) by pushing lamp in and turning it to left.
- END OF TASK

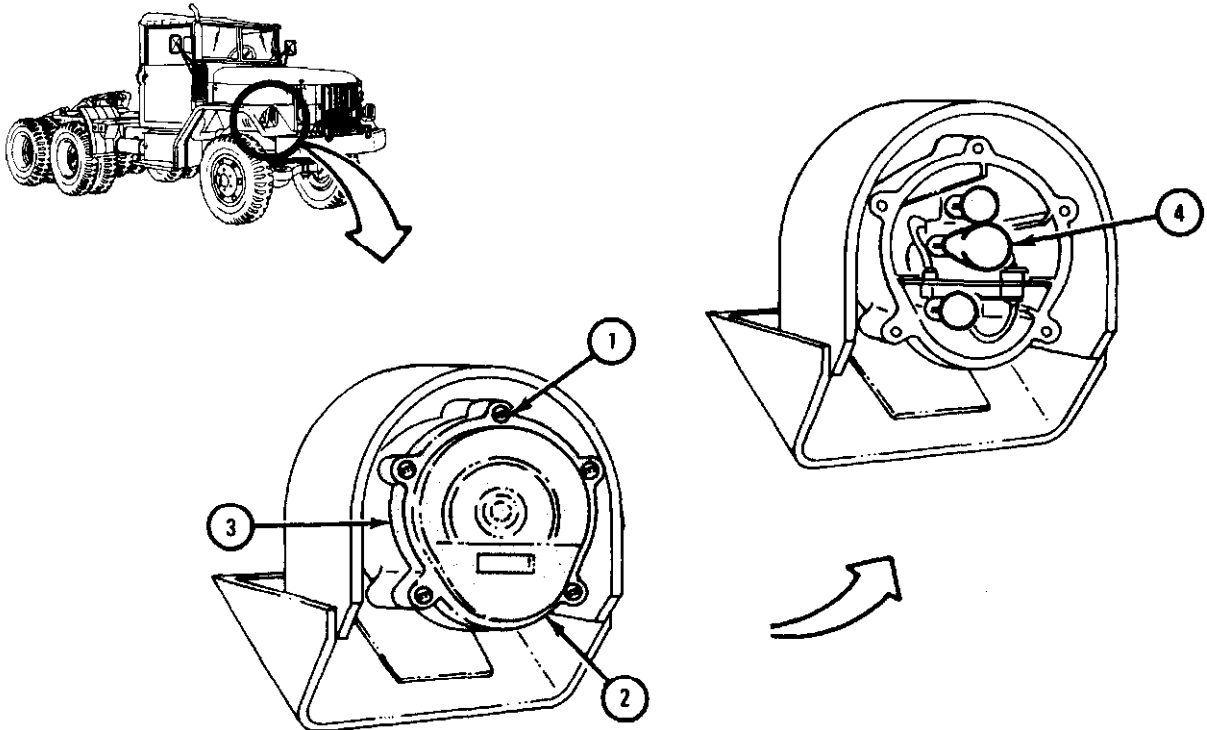

TA 046653

b. Replacement.

FRAME 1

NOTE

Larger lamp goes in middle socket.

1. Push lamp (1) into socket (2) and turn it to right.
2. Place gasket (3) into groove on door (4).
3. Put door (4) on light (5).
4. Using screwdriver, screw in and tighten five screws (6).

END OF TASK

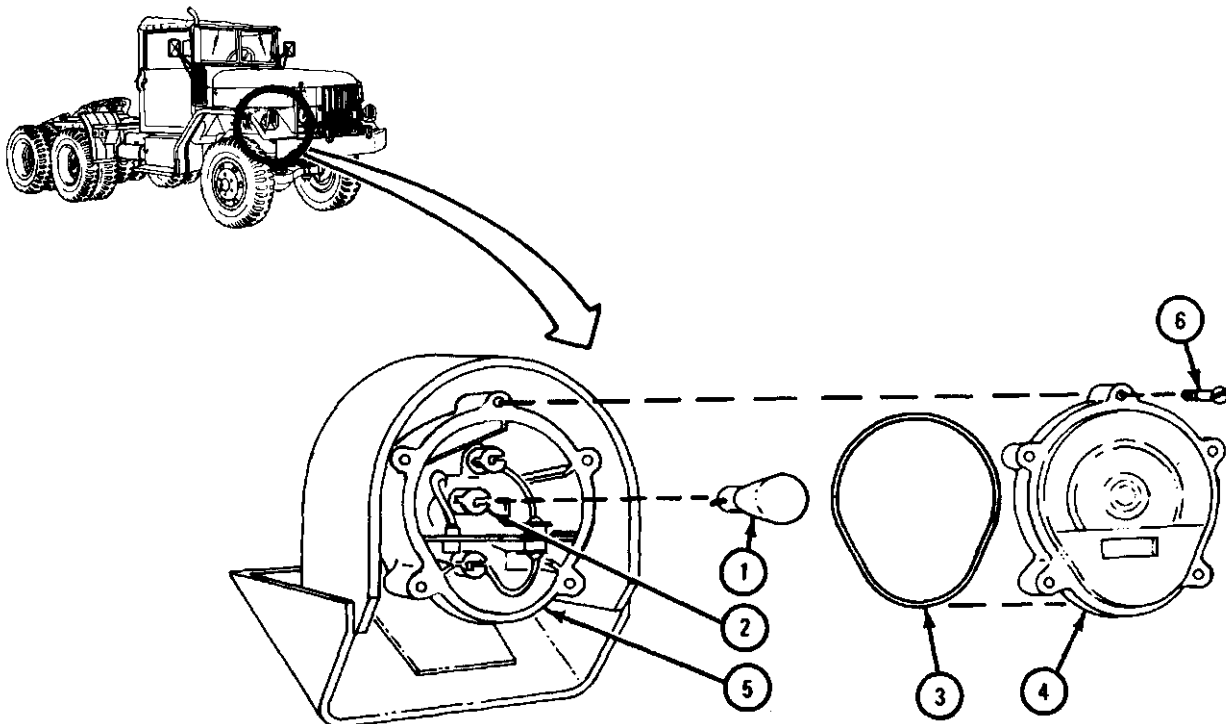

TA 046654

7-42. FRONT COMPOSITE LIGHT REPAIR.

TOOLS: None

SUPPLIES: Solvent, dry cleaning, type II (SD-2), Fed. Spec P-D-680
Soapy water

PERSONNEL: One

EQUIPMENT CONDITION: Truck parked, engine off, handbrake set, light switch
in OFF position.

a. Preliminary Procedures.

(1) Remove front composite light. Refer to para 7-40.

(2) Remove front composite light door and lamps. Refer to para 7-41.

b. Cleaning, Inspection, and Repair.

FRAME 1

1. Using soapy water, clean light door (1) and lens. Check lens for cracks or other damage.

WARNING

Dry cleaning solvent is flammable. Do not use near an open flame. Keep a fire extinguisher nearby when solvent is used. Use only in well-ventilated places. Failure to do this may result in injury to personnel and damage to equipment.

2. Using solvent, clean all other parts.
3. Check all screws for damaged threads.
4. Check light door (1) and housing (2) for dents, cracks, stripped threads or other damage. If any parts of housing are damaged, get a new front composite light.
5. Check gasket (3) for cracks and breaks.
6. Check lamps (4) for burned out filaments and for corroded contacts.
7. Check electrical connectors (5) for damage.
8. Throw away damaged parts. Get new parts in their place.

NOTE

Follow-on Maintenance Action Required:

1. Put composite lamps in sockets and replace light door. Refer to para 7-41.
2. Replace front composite light. Refer to para 7-40.

END OF TASK

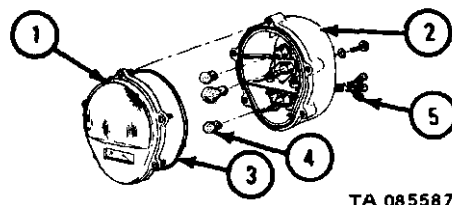

TA 085587

7-43. REAR COMPOSITE LIGHT AND BRACKET ASSEMBLY REMOVAL AND REPLACEMENT.

NOTE

This task is shown for truck M764. Brackets may be different on other trucks.

TOOLS: 9/16-inch wrench (2)

SUPPLIES: Tags

PERSONNEL: One

EQUIPMENT CONDITION: Truck parked, engine off, handbrake set.

Preliminary Procedure. Put main light switch in OFF position. Refer to TM 9-2320-209-10.

b. Removal.

FRAME 1

NOTE

Tag four wires (1) so they can be put back in the right place.

1. Unplug four wires (1).
2. Using wrenches, hold capscrew (2) and unscrew and take off nut (3). Spread open and take off wire clamp (4).
3. Using wrench, unscrew and take off capscrews (5) and two starwashers (6). Take off rear composite light (7).

GO TO FRAME 2

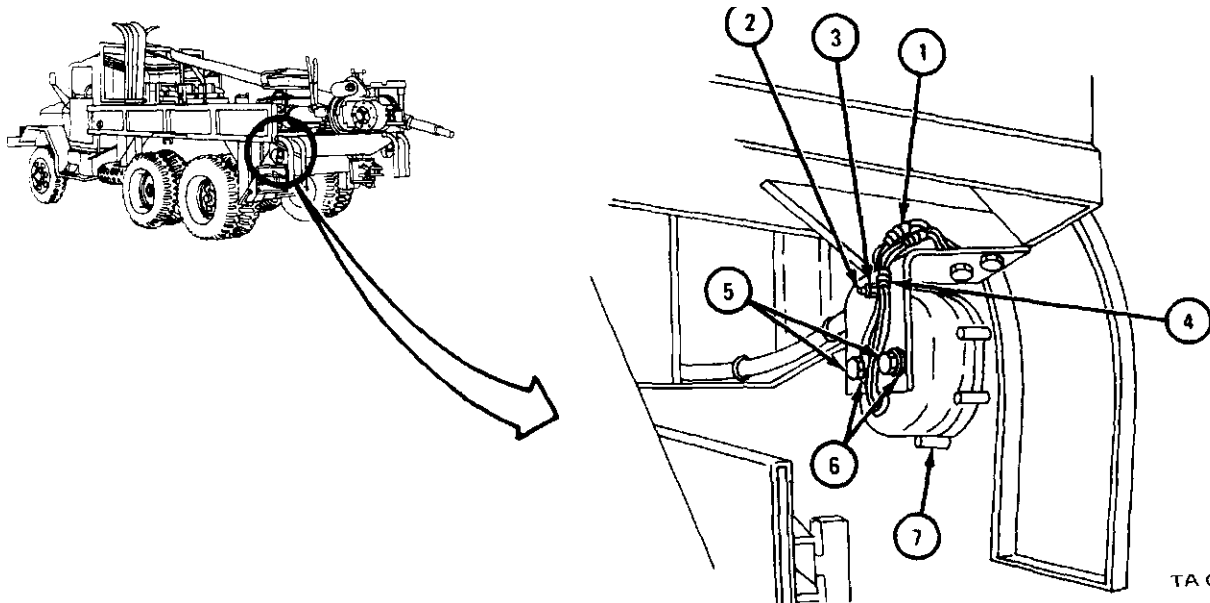

TA 046657

FRAME 2

1. Using 9/16-inch wrenches, hold two nuts (1) and unscrew and take off two capscrews (2). Take off bracket (3).

END OF TASK

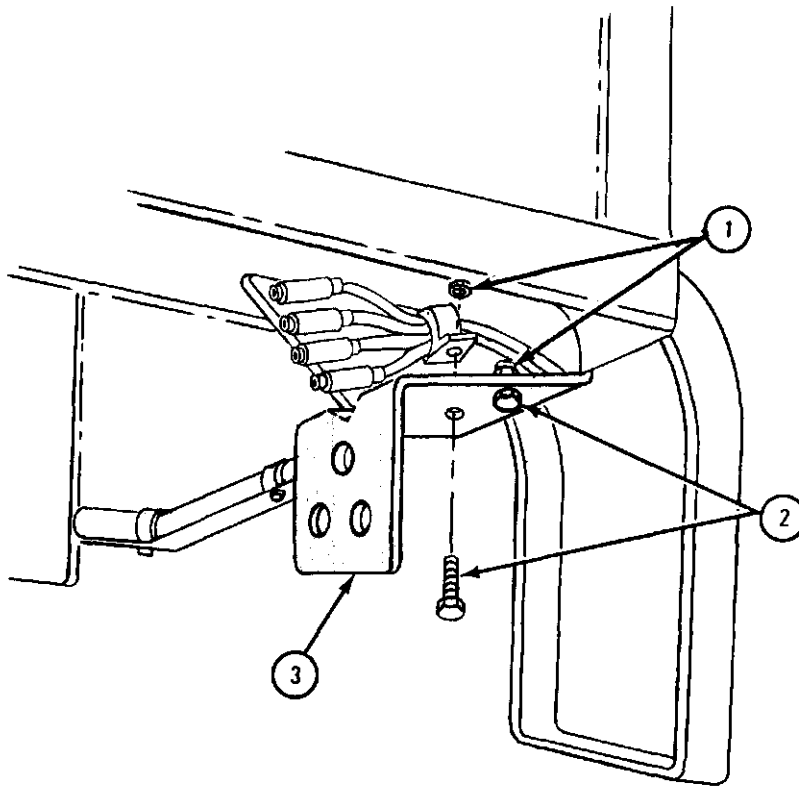

TA 083932

c. Replacement.

FRAME 1

1. Put bracket (1) in place as shown and aline screw holes.
2. Put cap screw (2) through bracket (1), truck body (3), and wire clamp (4). Screw on nut (5).
3. Using wrenches, screw in and tighten capscrew (6) and nut (7).
4. Using wrenches, tighten capscrew (2) and nut (5).

GO TO FRAME 2

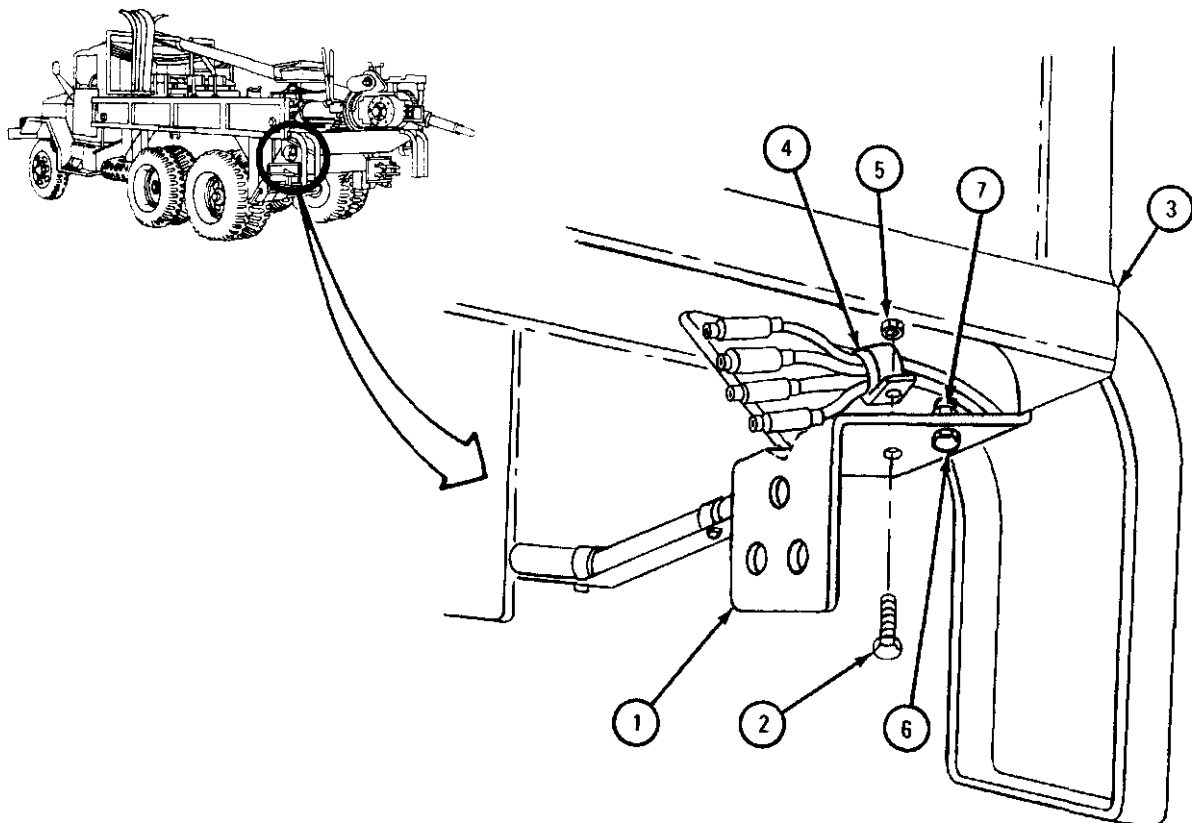

TA 046659

FRAME 2

1. Aline threaded screw holes in rear composite light (1) with holes in bracket (2).
 2. Using wrench, screw in and tighten two capscrews (3) with two star-washers (4).
 3. Put capscrew (5) through bracket (2). Put wire clamp (6) over four wires (7) and put wire clamp on capscrew.
 4. Using wrenches, hold cap screw (5) and screw on and tighten nut (8).
 5. Plug in four wires (7) into four connectors (9) as tagged. Take off tags.
- END OF TASK

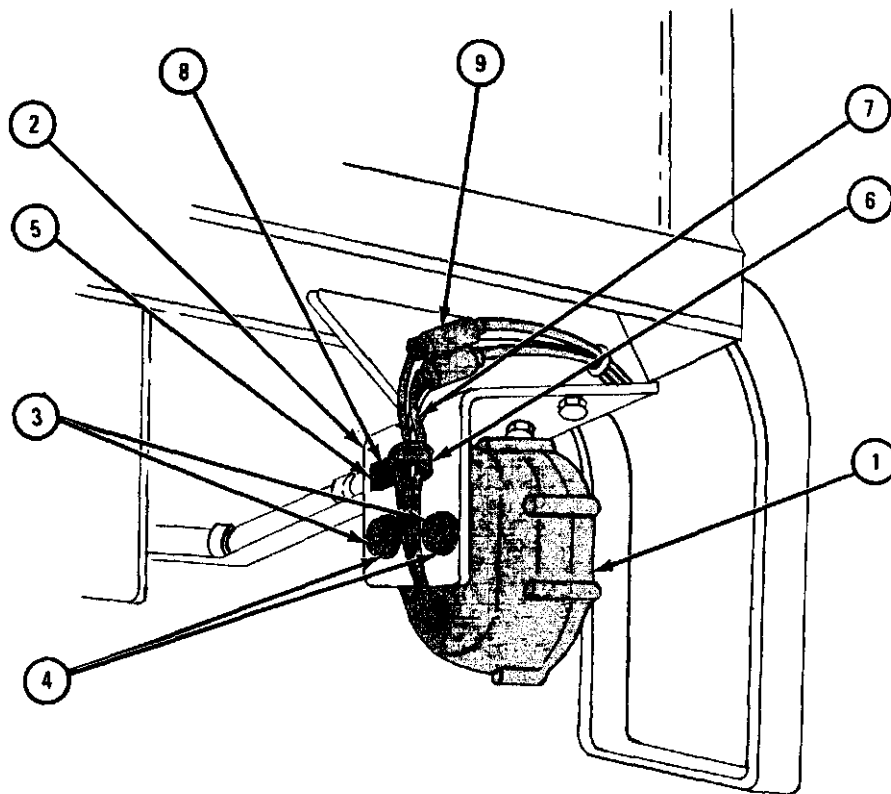

TA 083933

7-44. REAR COMPOSITE LIGHT REPAIR.

TOOLS: None

SUPPLIES: Solvent, dry cleaning, type II (SD-2), Fed. Spec P-D-680

PERSONNEL: One

EQUIPMENT CONDITION : Truck parked, engine off, handbrake set, light switch
in OFF position.

a. Preliminary Procedures.

(1) Remove rear composite light. Refer to para 7-43.

(2) Remove rear composite light door and lamps. Refer to para 7-45.

b. Cleaning, Inspection, and Repair.

FRAME 1

1. Using water and mild soap, clean light door (1) and lens. Check lens for cracks or other damage.

WARNING

Dry cleaning solvent is flammable. Do not use near an open flame. Keep a fire extinguisher nearby when solvent is used. Use only in well-ventilated places. Failure to do this may result in injury to personnel and damage to equipment.

2. Using solvent, clean all other parts.
3. Check all screws for stripped or damaged threads.
4. Check light door (1) and housing (2) for dents, cracks, stripped threads, or other damage. If any parts of housing are damaged, get a new rear composite light.
5. Check gasket (3) for cracks or breaks.
6. Check lamps (4) for burned out filaments and corroded contacts.
7. Check electrical connectors (5) for damage.
8. Throw away damaged parts and get new ones in their placed.

NOTE

Follow-on Maintenance Action Required:

1. Replace lamps in sockets and light door. Refer to para 7-45.
2. Replace rear composite light. Refer to para 7-43.

END OF TASK

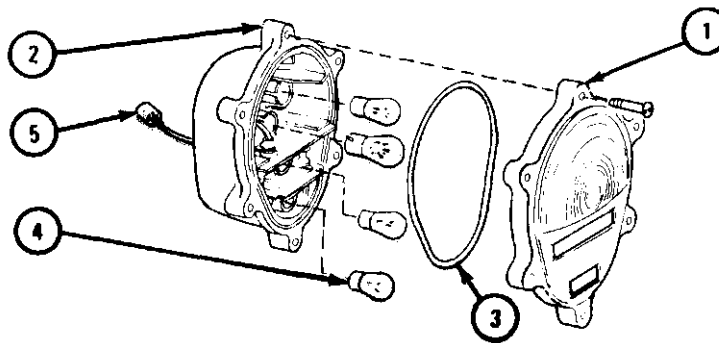

TA 085589

7-45. REAR COMPOSITE LAMPS REMOVAL AND REPLACEMENT.

TOOLS: Flat-tip screwdriver

SUPPLIES: None

PERSONNEL: One

EQUIPMENT CONDITION : Truck parked, engine off, handbrake set, light switch in OFF position.

a. Removal.

1. Using screwdriver, unscrew and take out six screws (1) in light door (2). Take off door and gasket (3).
2. Push in large lamp (4) and turn it to left. Take out lamp.
3. Push in three small lamps (5) and turn them to left. Take out lamps.

END OF TASK

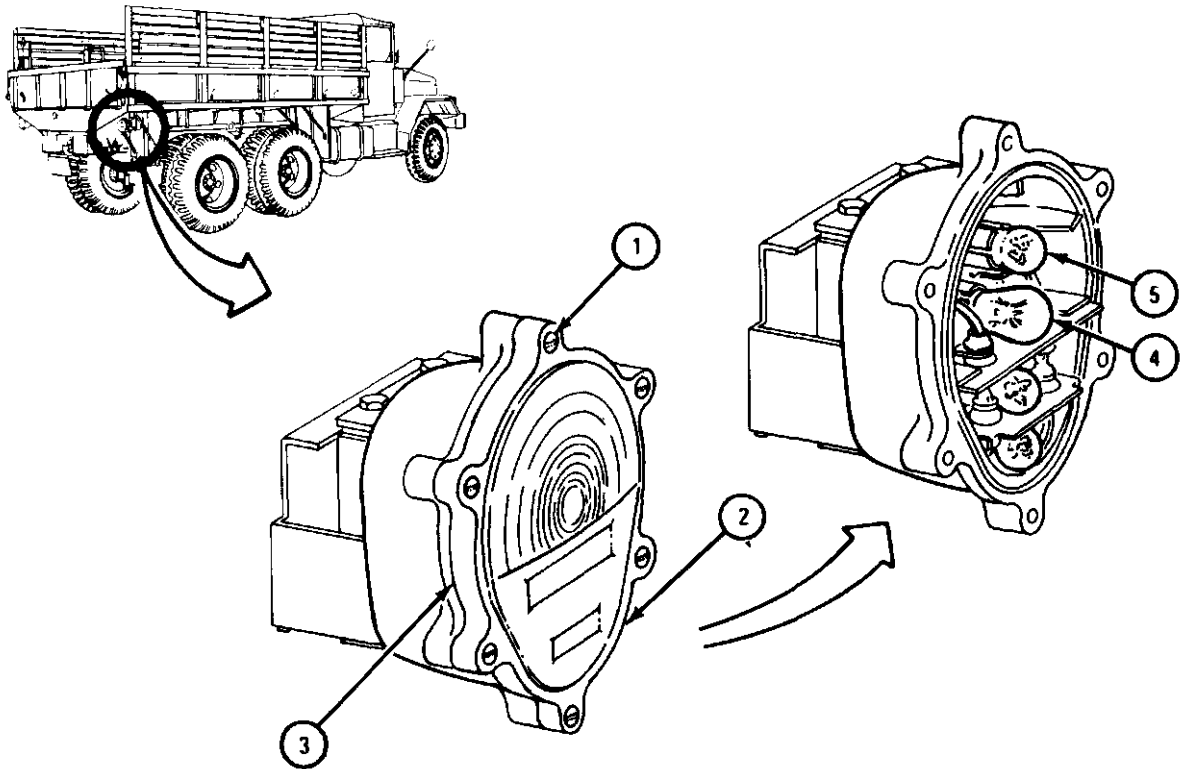

TA 085588

b. Replacement.

FRAME 1

1. Push large lamp (1) into socket (2) and turn it to right.
2. Push three small lamps (3) into three sockets (4) and turn them to right.
3. Place gasket (5) in groove on light door (6).
4. Place light door (6) on light (7).
5. Using screwdriver, screw in and tighten six screws (8).

END OF TASK

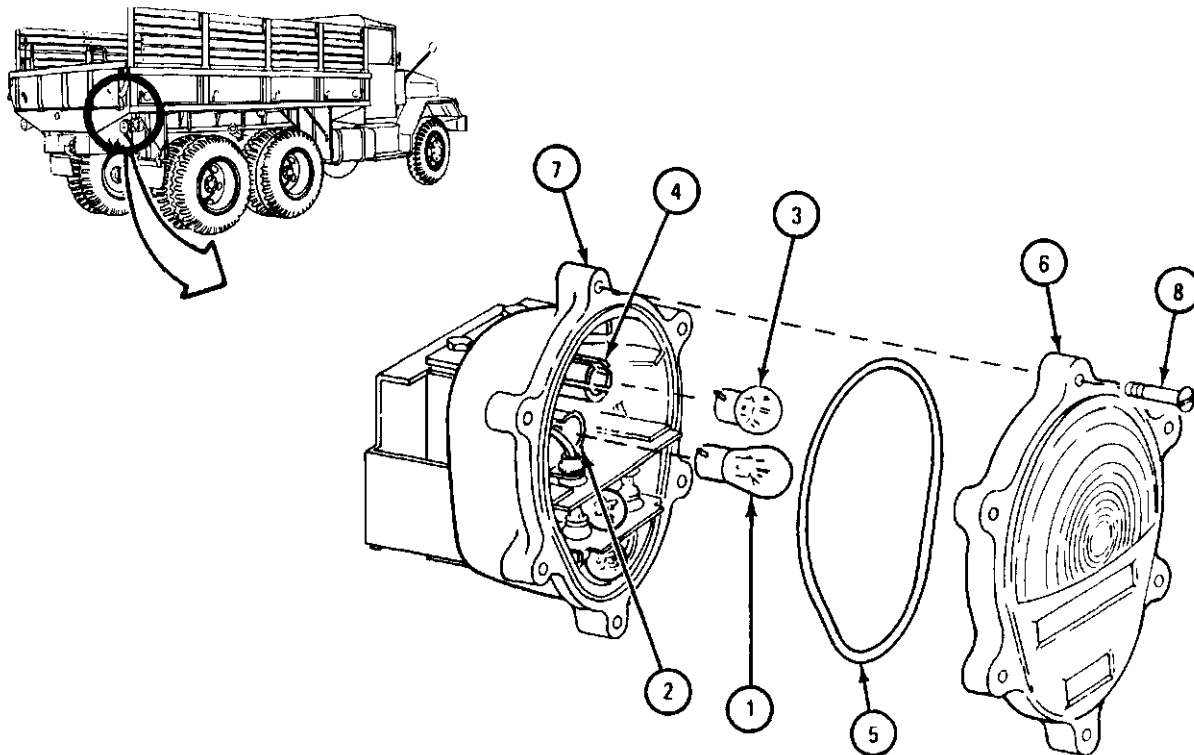

TA 046662

7-46. SERVICE AND BLACKOUT CLEARANCE LIGHTS REMOVAL AND REPLACEMENT (TRUCK M756A2).

TOOLS: Cross-tip screwdriver (Phillips type)
 Flat- tip screw driver
 3/8-inch wrench

SUPPLIES: None

PERSONNEL: One

EQUIPMENT CONDITION: Truck parked, engine off, handbrake set, light switch in OFF position.

Removal.

FRAME 1

1. Using phillips screwdriver, unscrew and take out two screws (1).
 2. Take off light door (2) with lens (3).
- GO TO FRAME 2

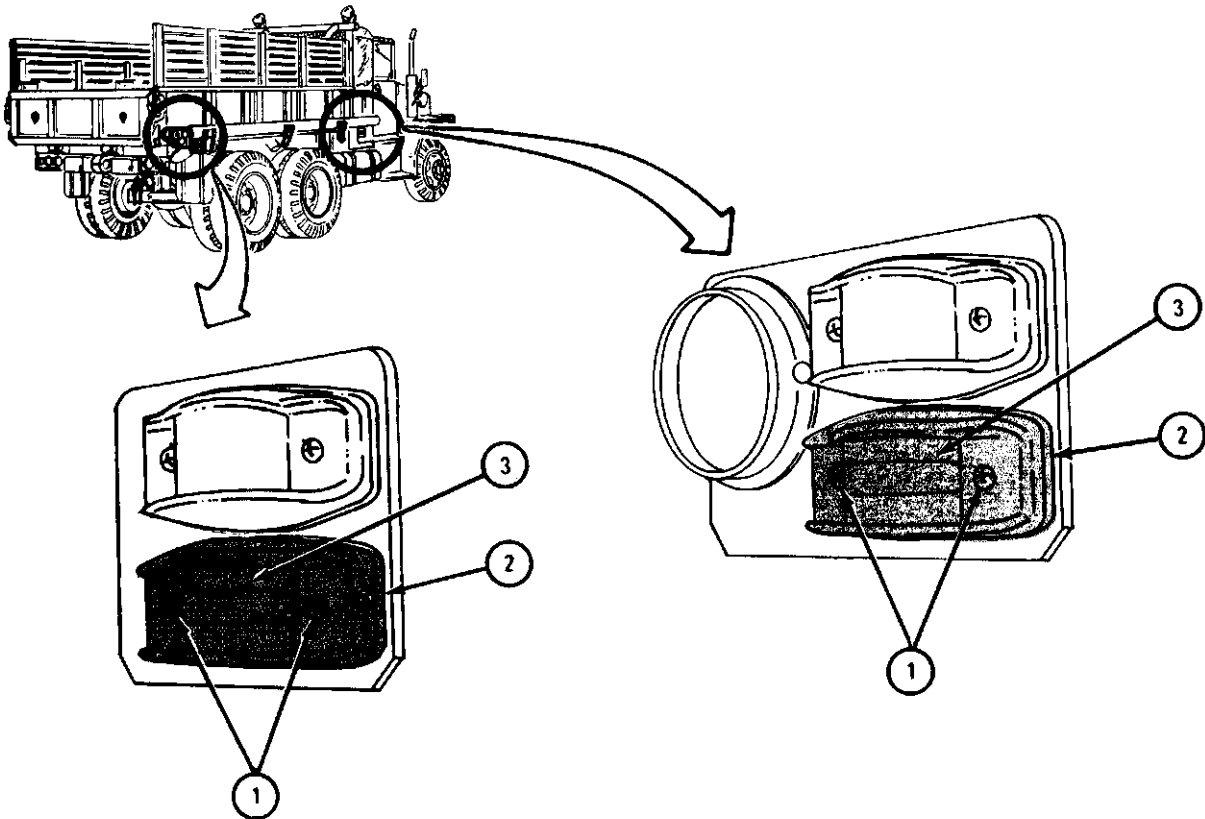

TA 046673

FRAME 2

1. Unplug electrical lead (1) from connector (2).
2. Using 3/8-inch wrench and flat-tip screwdriver, unscrew and take off four nuts (3), four lockwashers (4), and four screws (5).
3. Take out lamp base (6) from front of bracket (7).

END OF TASK

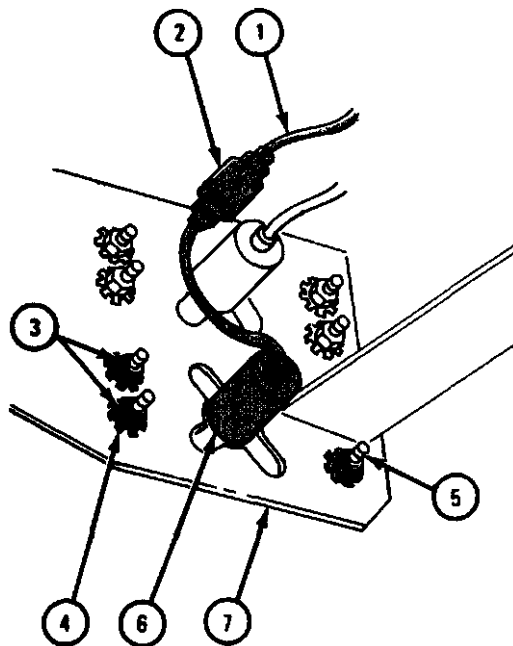

TA 085591

b. Replacement.

FRAME 1

1. Put lamp base (1) on bracket (2) from front with electrical connector (3) through center hole. Put four screws (4) through lamp base and bracket from front. Put on four lockwashers (5) and four nuts (6).
2. Using 3/8-inch wrench and flat-tip screwdriver, tighten four nuts (6).
3. Plug electrical lead (7) into connector (3).

GO TO FRAME 2

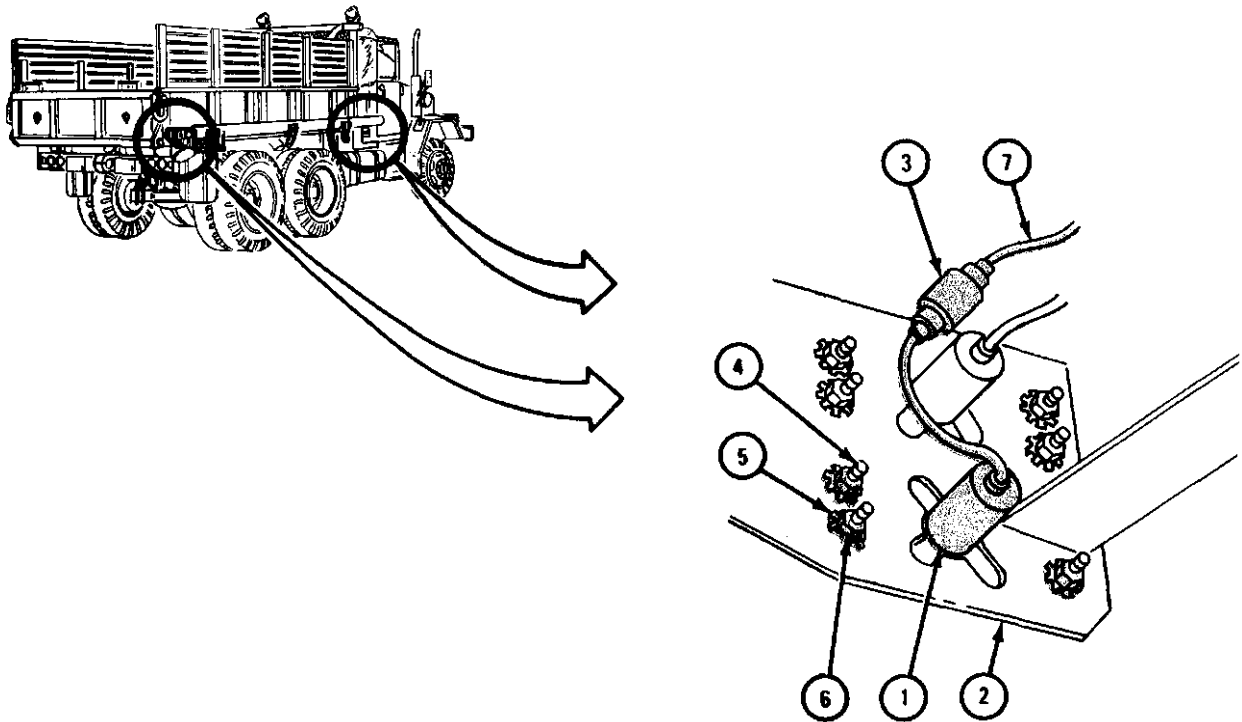

TA 046674

FRAME 2

NOTE

Bottom of lens is marked BOTTOM.

1. Put light door (1) with lens (2) on bracket (3).
2. Using phillips screwdriver, screw in and tighten two screws (4).

END OF TASK

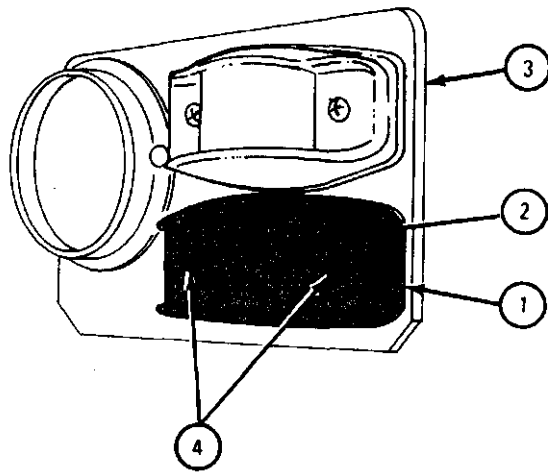

TA 046675

7-47. SERVICE AND BLACKOUT CLEARANCE LAMPS REMOVAL AND REPLACEMENT.

NOTE

This task is the same for service and blackout clearance lamps on all trucks.

TOOLS: Cross-tip screwdriver (Phillips type)

SUPPLIES: None

PERSONNEL: One

EQUIPMENT CONDITION: Truck parked, engine off, handbrake set, light switch in OFF position.

a. Removal.

FRAME 1

1. Using screwdriver, unscrew and take out two screws (1).
2. Take off light door (2) with lens (3).
3. Push lamp (4) in and turn it 1/4 turn to left. Take out lamp.

END OF TASK

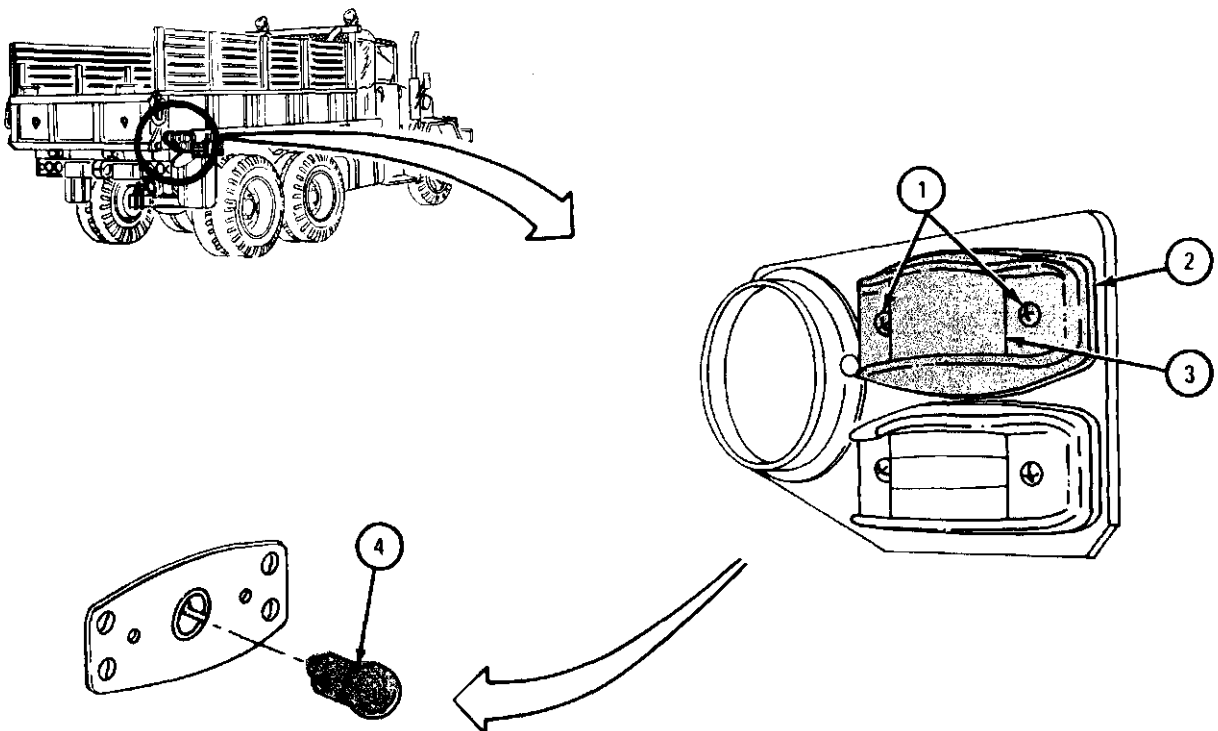

TA 046678

b. Replacement.

FRAME 1

1. Push lamp (1) into socket (2) and turn it 1/4 turn to right.
2. Put light door (3) with lens (4) on light housing (5).
3. Using screwdriver, screw in and tighten two screws (6).

END OF TASK

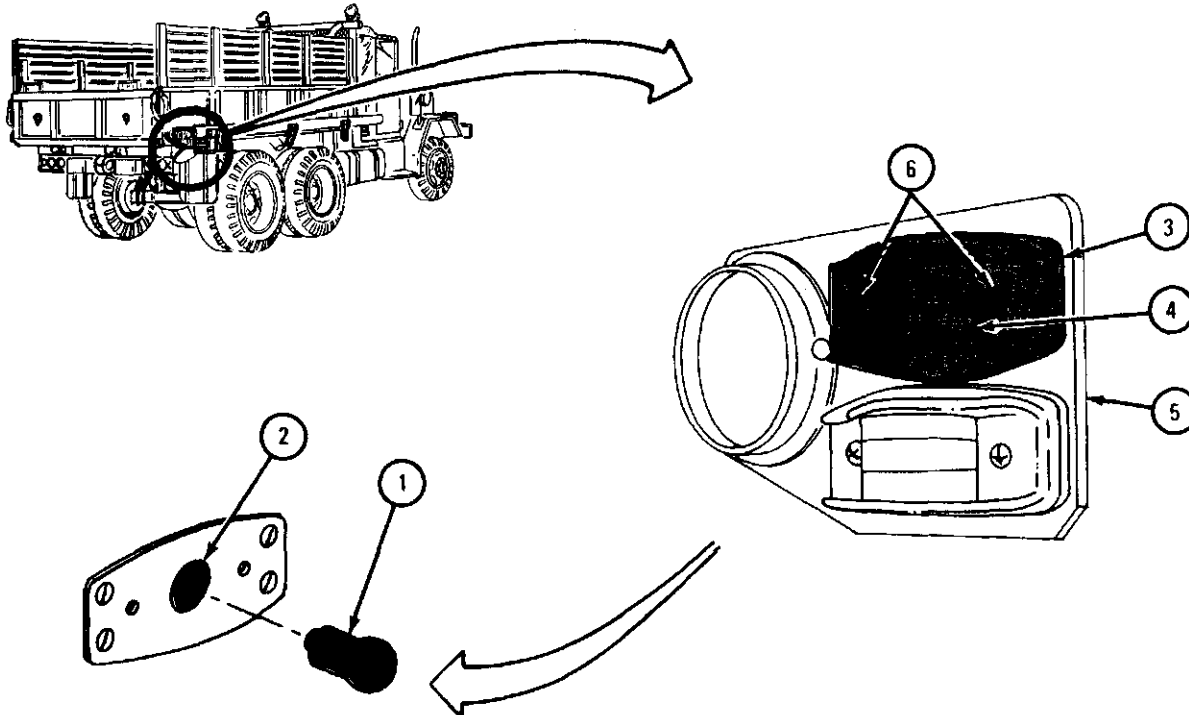

TA 046679

Section VI. SENDING UNIT GAGES AND WARNING BUZZERS

7-48. WATER TEMPERATURE TRANSMITTER REMOVAL AND REPLACEMENT.

TOOLS: 15/16-inch wrench

SUPPLIES: Sealer compound, type II, MIL-S-45180

PERSONNEL: One

EQUIPMENT CONDITION: Truck parked, engine off, handbrake set.

a. Preliminary Procedures.

(1) Open hood and right side panel. Refer to TM 9-2320-209-10.

(2) Drain cooling system (eight quarts) to drop coolant level below engine intake manifold. Refer to para 6-10.

(3) Disconnect battery ground cable. Refer to para 7-58.

CAUTION

Make sure ACCESSORY switch is set to OFF position while doing this procedure to prevent electrical damage.

b. Removal.

FRAME 1

1. Take connector (1) off water temperature transmitter (2).
2. Using 15/16-inch wrench, unscrew water temperature transmitter (2) from intake manifold (3).

END OF TASK

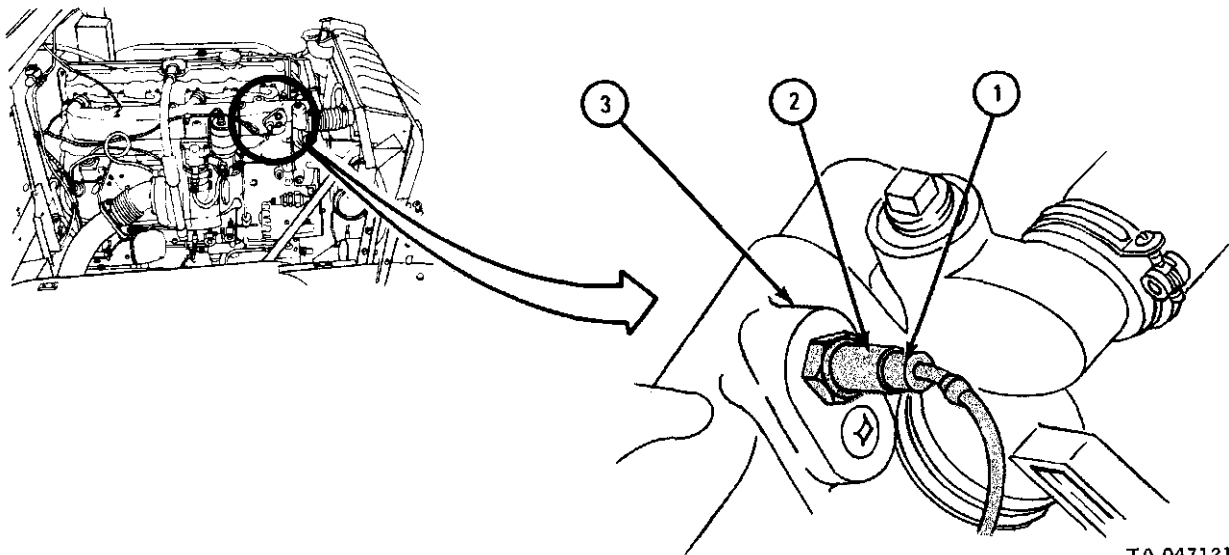

TA 047121

c. Replacement.

FRAME 1

1. Put a thin coating of sealer compound on threads (1) of temperature transmitter (2).
2. Using 15/16-inch wrench, screw in and tighten temperature transmitter (2) into hole in intake manifold (3).
3. Plug connector (4) into temperature transmitter.

NOTE

Follow-on Maintenance Action Required:

1. Fill cooling system. Refer to para 6-10.
2. Check that operation of water temperature gage. Refer to TM 9-2320-209-10.
3. Check temperature transmitter for leaks.
4. Close hood and right side panel. Refer to TM 9-2320-209-10.
5. Reconnect battery ground cable. Refer to para 7-58.

END OF TASK

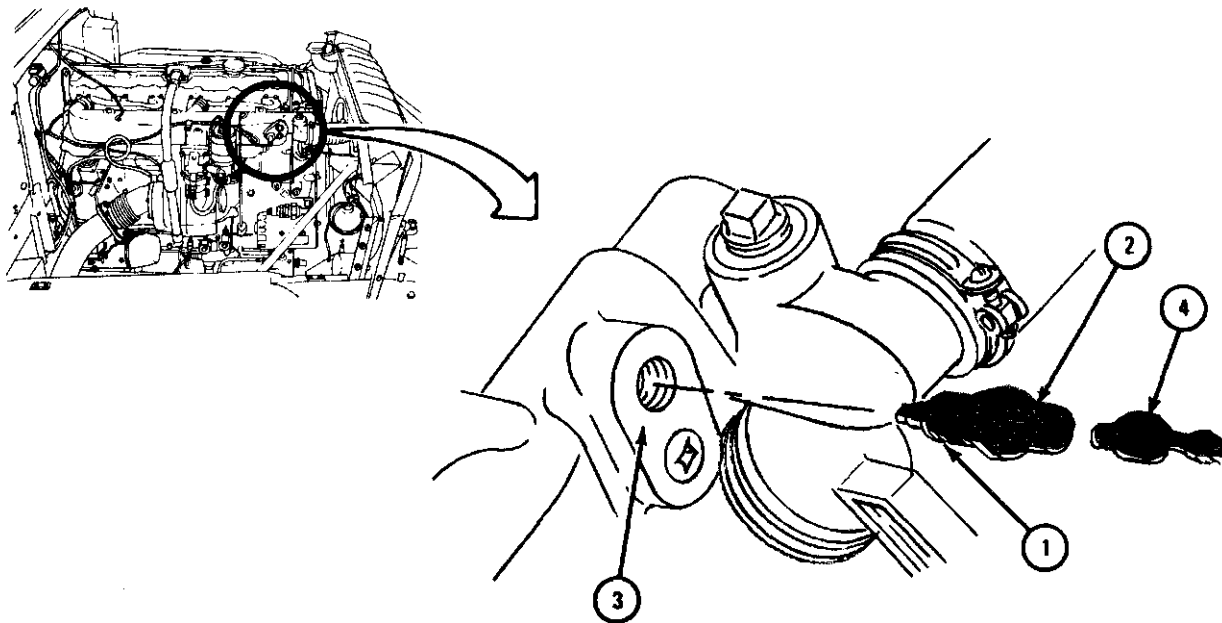

TA 047122

7-49. OIL PRESSURE TRANSMITTER REMOVAL AND REPLACEMENT.

TOOLS: 3/4-inch open end wrench (2)

SUPPLIES: Heat resistant sealer, type II, MIL-S-45180

PERSONNEL: One

EQUIPMENT CONDITION: Truck parked, engine off, handbrake set.

Preliminary Procedure. Remove air cleaner filter element. Refer to TM 9-2320-209-10.

CAUTION

Make sure ACCESSORY switch is set to OFF position while doing this procedure. Failure to do this may cause a short and damage wiring or transmitter.

b. Removal.**FRAME 1**

1. Take connector (1) off oil pressure transmitter (2).
2. Using 3/4-inch wrench, unscrew oil pressure transmitter (2) from adapter fitting (3). Hold adapter fitting from turning in elbow (4) with 3/4-inch wrench.

END OF TASK

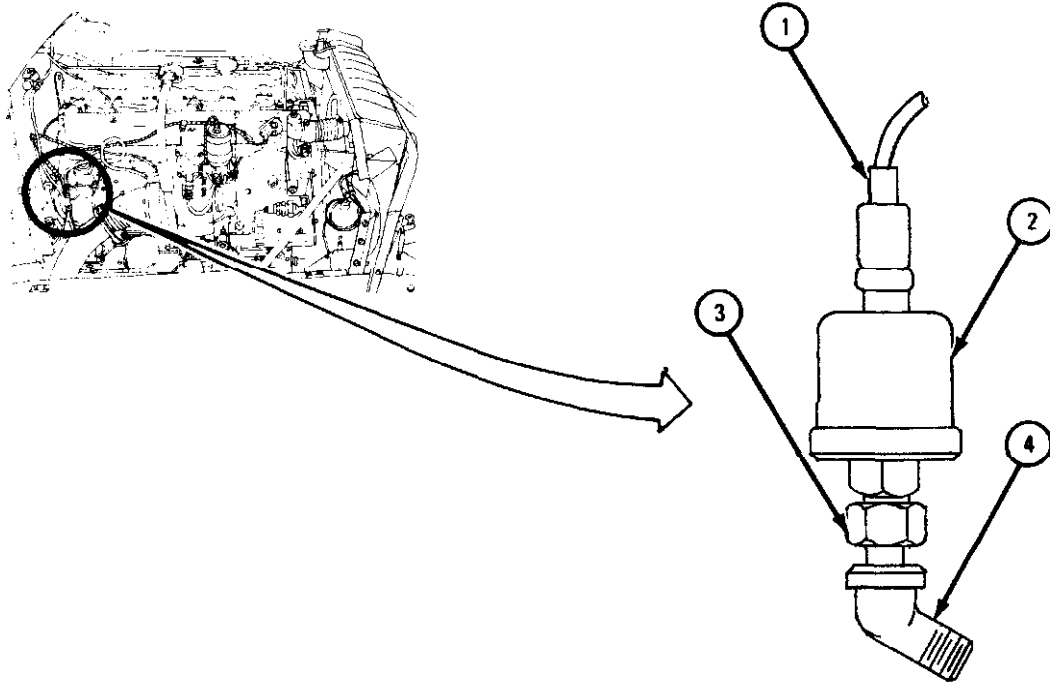

TA 047123

c. Replacement.

FRAME 1

1. Put a thin coating of heat resistant sealer on threads (1) of oil pressure transmitter (2).
2. Using 3/4-inch wrench, screw oil pressure transmitter (2) into adapter fitting (3). Using 3/4-inch wrench to hold adapter fitting from turning on elbow (4).
3. Plug connector (5) into oil pressure transmitter (2).

NOTE

Follow-on Maintenance Action Required:

1. Check operation of oil pressure gage. Refer to TM 9-2320-209-10.
2. Check oil pressure transmitter fittings for oil leaks.
3. Replace air cleaner filter element. Refer to TM 9-2320-209-10.

END OF TASK

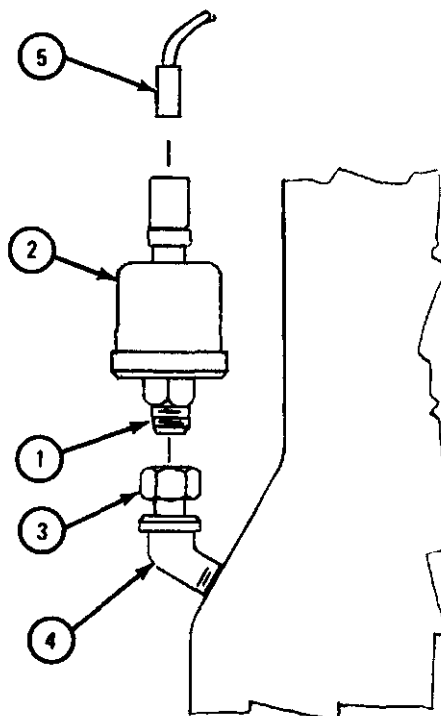
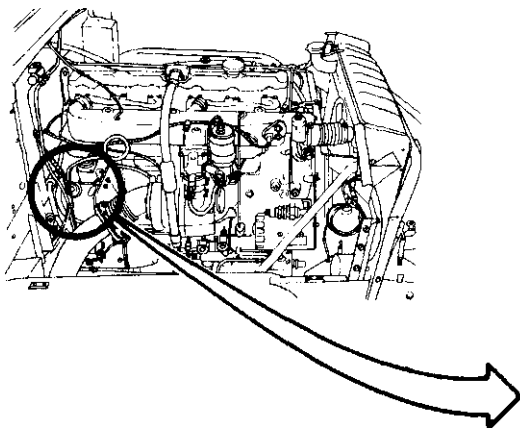

TA 047124

7-50. FUEL GAGE SENDING UNIT REMOVAL AND REPLACEMENT.

TOOLS: Cross-tip screwdriver (Phillips type)
6x6-inch sheet metal

SUPPLIES: Gasket
Dry cleaning solvent, type II (SD-2), Fed. Spec P-D-680

PERSONNEL: One

EQUIPMENT CONDITION: Truck parked, engine off, handbrake set.

a. Preliminary Procedures.

(1) Disconnect battery ground cable. Refer to para 7-58.

(2) Drain fuel tank. Refer to TM 9-2320-209-10.

(3) On truck M342A2, remove spare wheel (refer to TM 9-2320-209-10) and remove outer spare wheel carrier. Refer to Part 2, para 16-9.

(4) On truck M756A2, partially remove fuel tank. Refer to para 4-6.

b. Removal.

FRAME 1

1. Take connector (1) off sending unit (2).
2. Using screwdriver, unscrew five screws (3) and take off five copper washers (4).
3. Carefully lift sending unit (2) out of fuel tank (5). Throw away gasket (6).

CAUTION

Cover hole in fuel tank with sheet metal, to keep out dirt until sending unit is put back.

END OF TASK

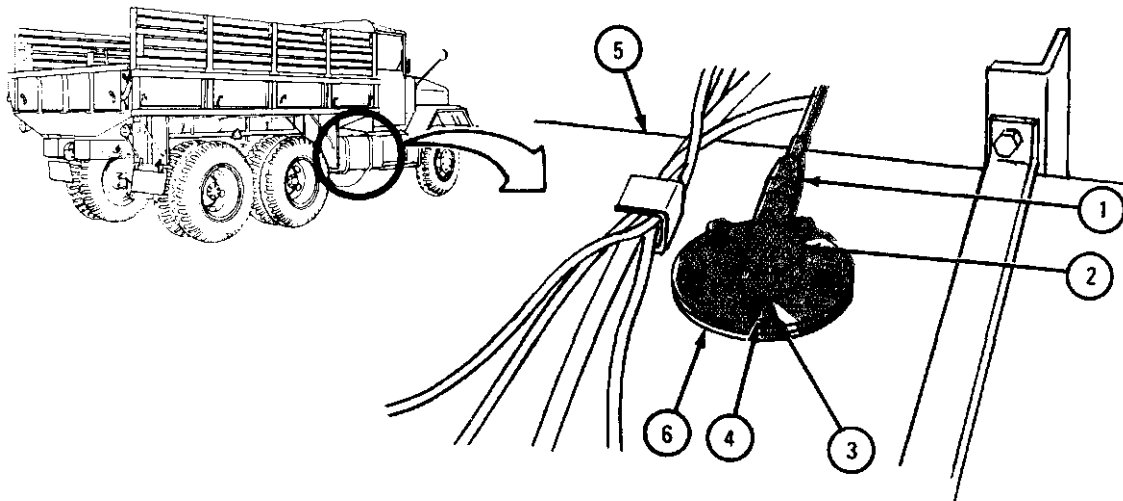

TA 047126

c. Replacement.

WARNING

Dry cleaning solvent is flammable. Do not use near an open flame. Keep a fire extinguisher nearby when solvent is being used. Use only in well-ventilated places. If this is not done, there may be injury to personnel and damage to equipment.

FRAME 1

1. Using dry cleaning solvent, clean surface of mounting flange on sending unit (1) mounting flange and mating flange on fuel tank (2).
2. Put gasket (3) on fuel tank (2) flange and align five holes.
3. Carefully put float arm (4) into tank. Align mounting holes in sending unit (1) with five holes in flange of fuel tank (2) as shown.

GO TO FRAME 2

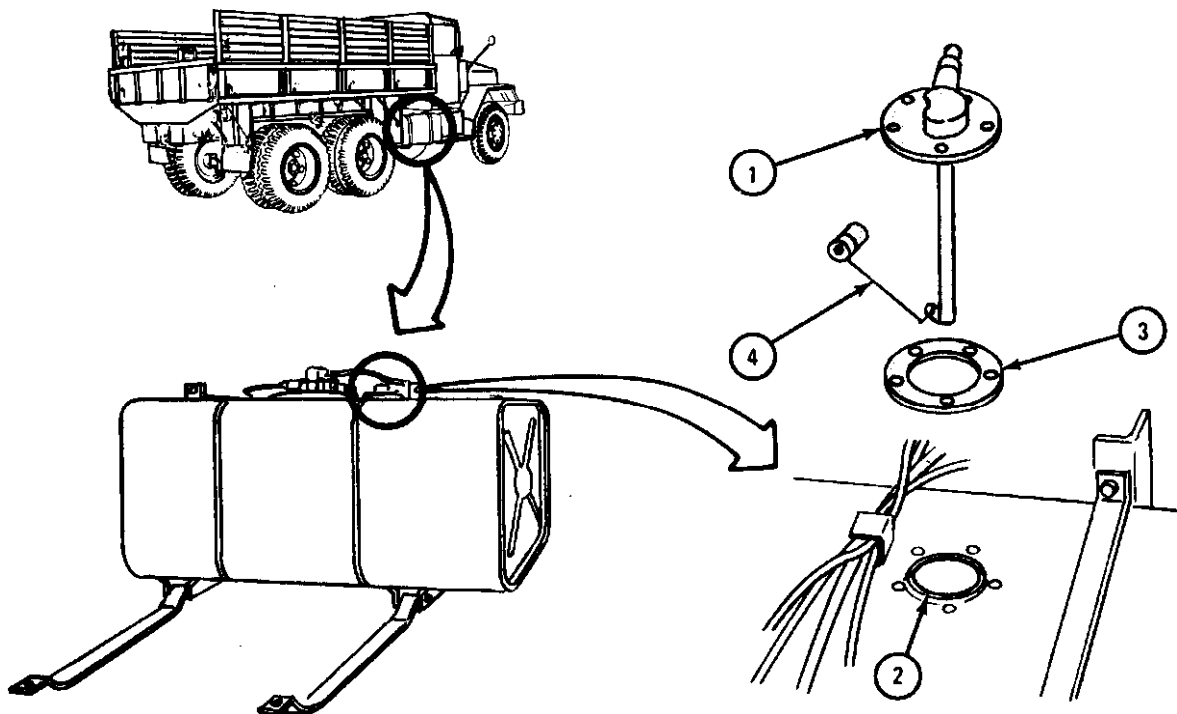

TA 047127

FRAME 2

1. Join sending unit (1) to fuel tank flange (2) using five screws (3) with copper washers (4).
2. Using screwdriver, tighten five screws (3) evenly.
3. Plug connector (5) into sending unit (1).

NOTE

Follow-on Maintenance Action Required:

1. Fill fuel tank. Refer to TM 9-2320-209-10. Check FUEL LEVEL gage before and after filling fuel tank to be sure fuel sending unit is operating properly.
2. Reconnect battery ground cable. Refer to para 7-58.

END OF TASK

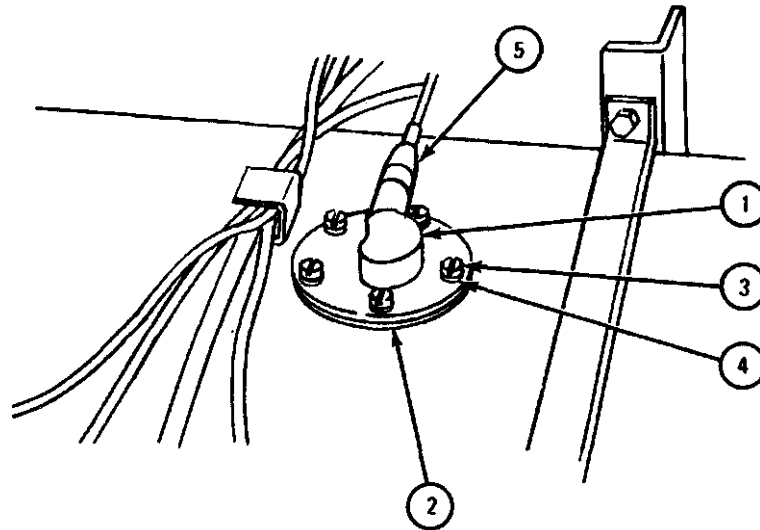

TA 115426

7-51. LOW AIR PRESSURE BUZZER REMOVAL AND REPLACEMENT.

TOOLS: 7/16-inch socket wrench (2)

SUPPLIES: None

PERSONNEL: Two

EQUIPMENT CONDITION: Truck parked, engine off, handbrake set.

a. Removal.

FRAME 1

- Soldier A 1. Unplug connector (1) from buzzer (2).
- Soldier B 2. Open engine compartment hood. Refer to TM 9-2320-209-10.
3. Using 7/16-inch wrench, hold three screws (3).
- Soldier A 4. Using 7/16-inch wrench, unscrew three safety nuts (4). Take off buzzer (2).

END OF TASK

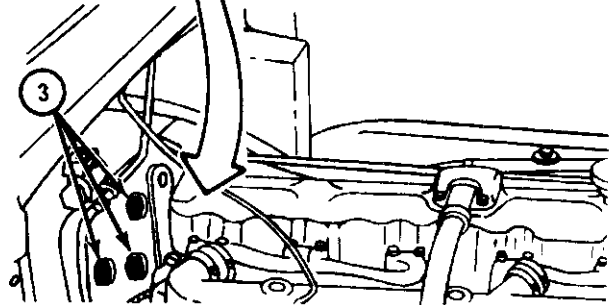
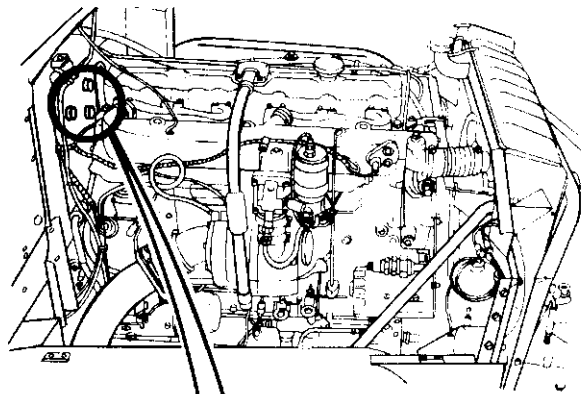
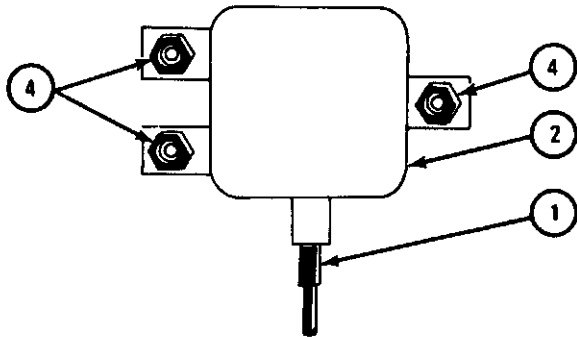
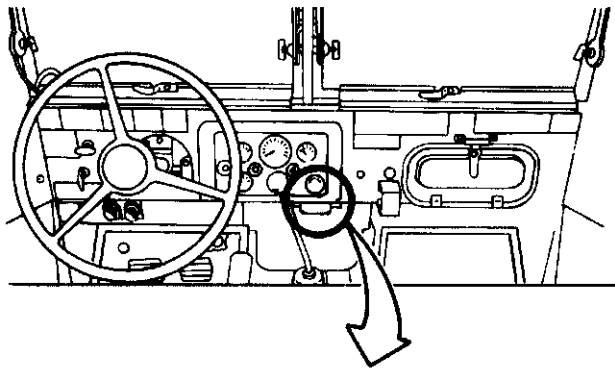

TA 046181

b. Replacement.

FRAME 1

- Soldier A 1. Put buzzer (1) against firewall with connector (2) pointing down. Line up three mounting holes in buzzer (1) with holes in firewall.
- Soldier B 2. Put three screws (3) through holes in firewall and hold with 7/16-inch wrench.
- Soldier A 3. Using 7/16-inch wrench, screw on three safety nuts (4). Plug connector (2) into buzzer (1).

NOTE

Follow-on Maintenance Action Required:

Check operation of buzzer. Refer to TM 9-2320-209-10.

END OF TASK

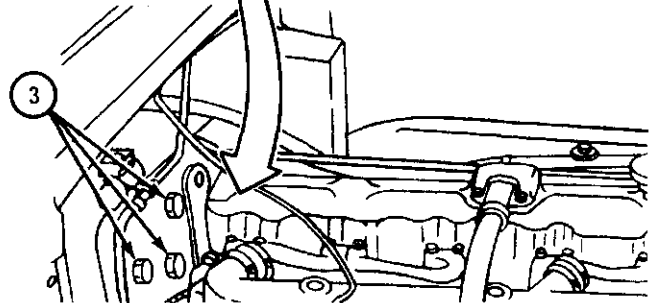
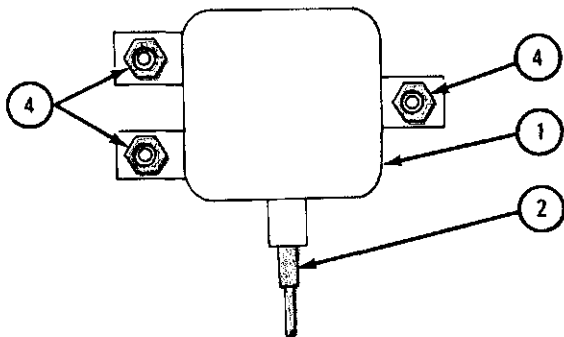
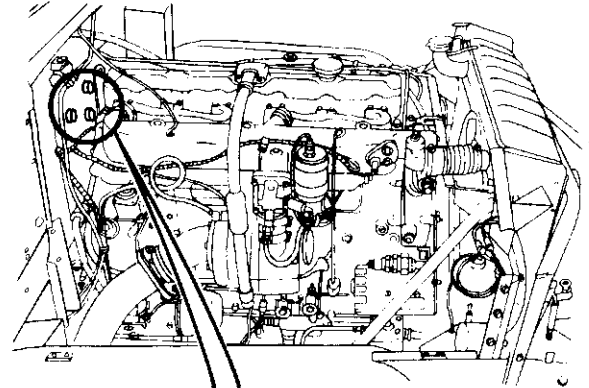
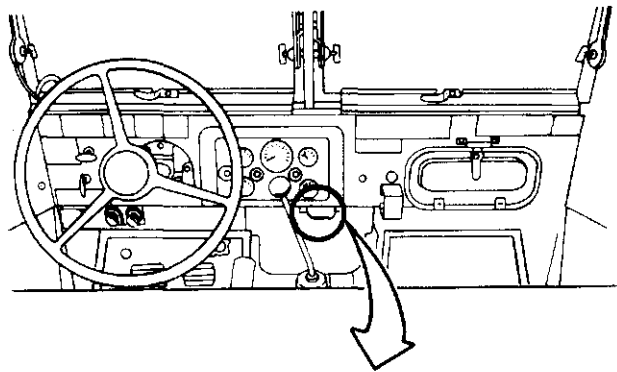

TA 046182

Section VII. HORN ASSEMBLY

7-52. HORN BUTTON REMOVAL, REPAIR, AND REPLACEMENT.

TOOLS: Flat-tip screwdriver

SUPPLIES: Solvent, dry cleaning, type II (SD-2), Fed. Spec P-D-680
Safety wire, MS 20995-N51-18

PERSONNEL : One

EQUIPMENT CONDITION: Truck parked, engine off, handbrake set.

a. Preliminary Procedures.

(1) Open left side panel. Refer to TM 9-2320-209-10.

(2) Disconnect battery ground cable. Refer to para 7-58.

b. Removal.

FRAME 1

1. Lift rubber cap (1) off horn button (2). Press down on horn button and turn to left one quarter turn.

2. Lift off horn button (2) and take out contact (3), spring (4), and cap (5).

GO TO FRAME 2

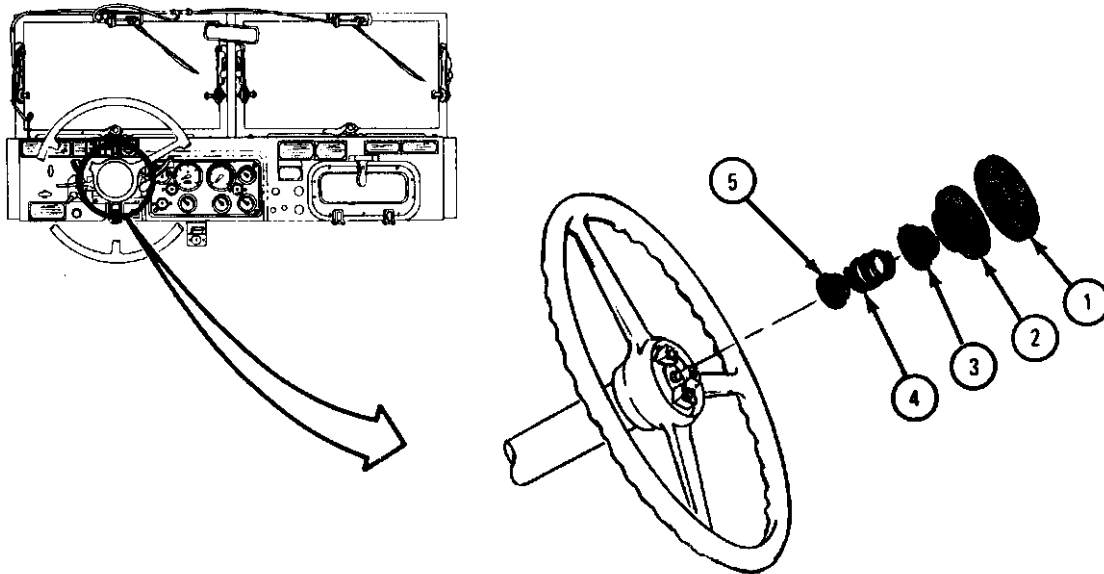

TA 047200

FRAME 2

1. Pull plug (1) out of connector shell (2). Slide shell back on horn wire (3) as shown.
2. Take off slotted washer (4) and slide shell (2) off horn wire (3).
3. Take rubber bushing (5) out of steering gear box (6). Slide rubber bushing off horn wire (3).

NOTE

Safety wire must be long enough to reach the other end of steering column, plus two feet.

4. Fasten a length of light safety wire (7) to end of horn wire (3).

GO TO FRAME 3

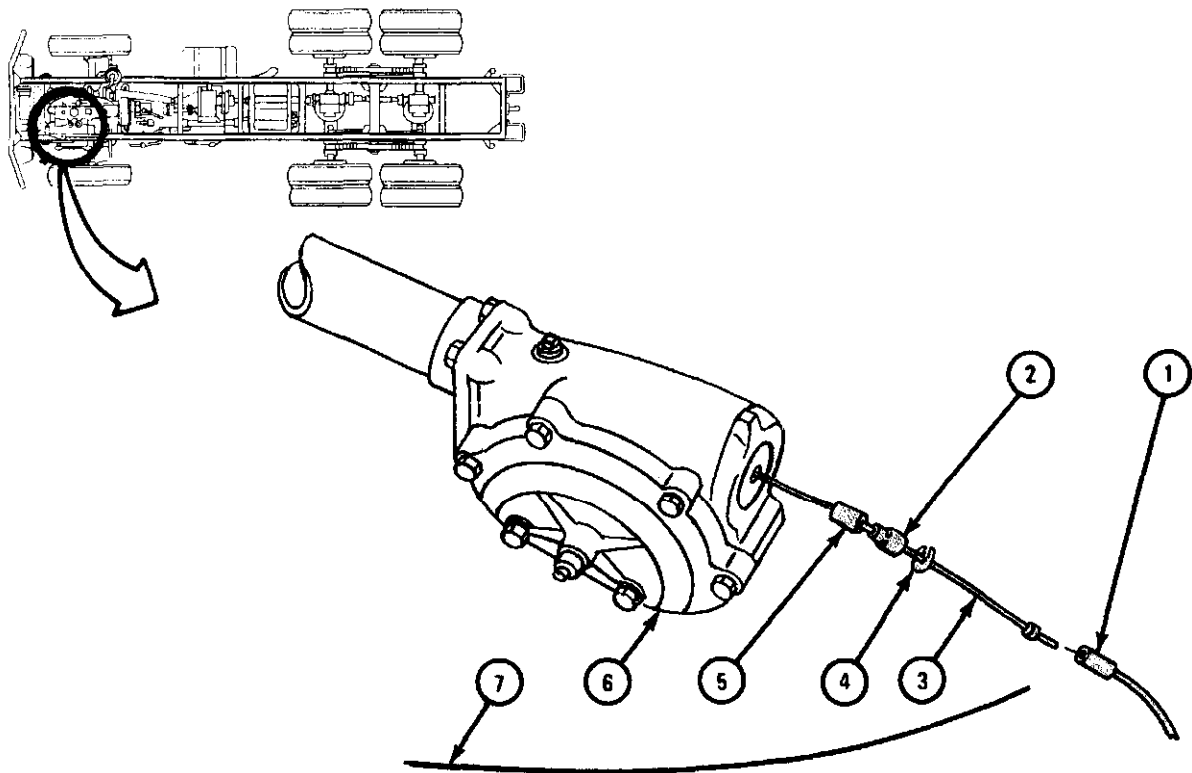

TA 047201

FRAME 3

NOTE

Leave safety wire (6) in steering column (5). It will be used to pull new horn wire through steering column.

1. Using screwdriver, unscrew and take out three screws (1). Lift out base plate (2).
2. Slide insulator (3) off horn wire (4).
3. Pull horn wire (4) out of steering column (5). Unfasten safety wire (6) from horn wire.
4. Take out spring (7) and contact washer (8).

END OF TASK

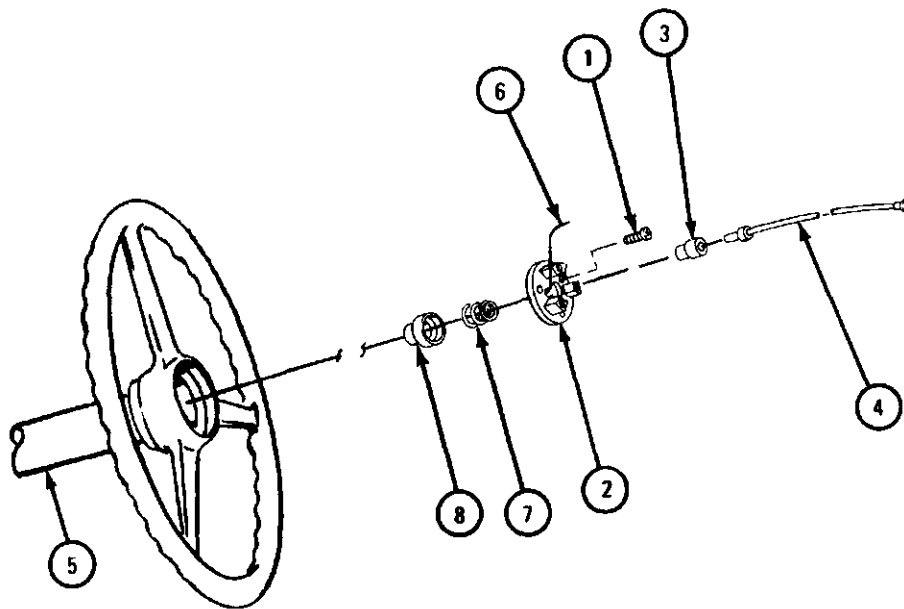

TA 047202

c. Repair. Repair the horn button by replacing any worn or damaged parts. The horn button parts kit contains all parts shown in this procedure except the cable. The cable must be ordered separately.

WARNING

Dry cleaning solvent is flammable. Do not use near an open flame. Keep a fire extinguisher nearby when solvent is used. Use only in well-ventilated places. Failure to do this may result in injury to personnel and damage to equipment.

d. Cleaning. Before assembling horn button, clean all contacts using solvent. Wipe out button recess in steering wheel.

e. Replacement.

FRAME 1

1. Put safety wire (1) through contact washer (2), spring (3), and base plate (4). Set base plate in hub (5) and align three holes in base plate with holes in hub.
2. Using screwdriver, screw three screws (6) through base plate (4) into hub (5).
3. Slip insulator (7) over terminal end of horn cable (8) as shown.
4. Join safety wire (1) to terminal end of horn cable (8).

GO TO FRAME 2

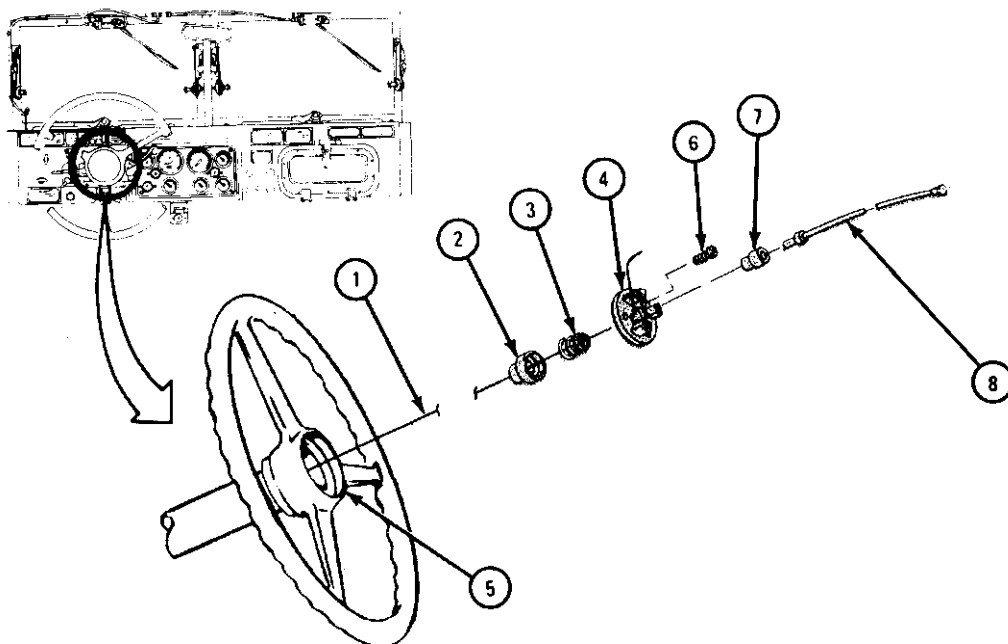

TA 047203

FRAME 2

1. Carefully pull end of safety wire (1) out through hole in steering gearbox (2). When terminal end of horn cable (3) comes out through hole, take off safety wire.
2. Slip rubber bushing (4) and connector shell (5) over end of horn cable (3).
3. Put slotted washer (6) on horn cable (3) behind terminal (7). Slide shell (5) down over terminal.

GO TO FRAME 3

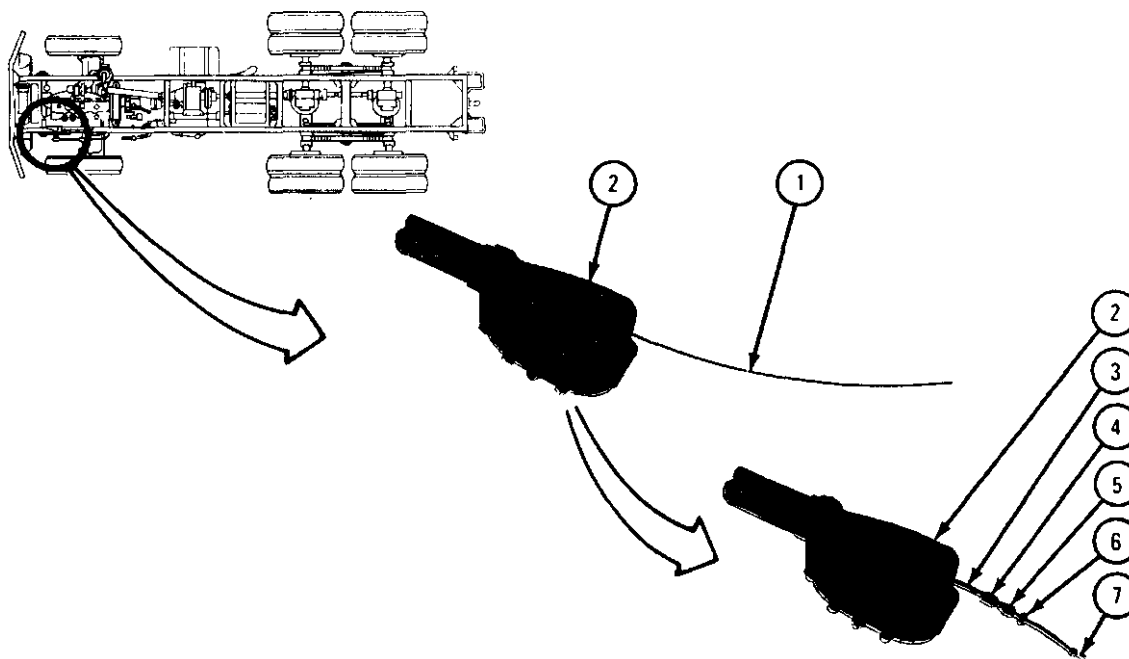

TA 047204

FRAME 3

1. Center insulator (1) in baseplate (2). Push contact (3) firmly into insulator. (No cable should show.)
2. Put contact (4), spring (5), and cap (6) together in horn button (7) as shown.
3. Center horn button (7) over base plate (2). Press down and turn to right until it is locked.
4. Put rubber cover (8) on horn button (7).

GO TO FRAME 4

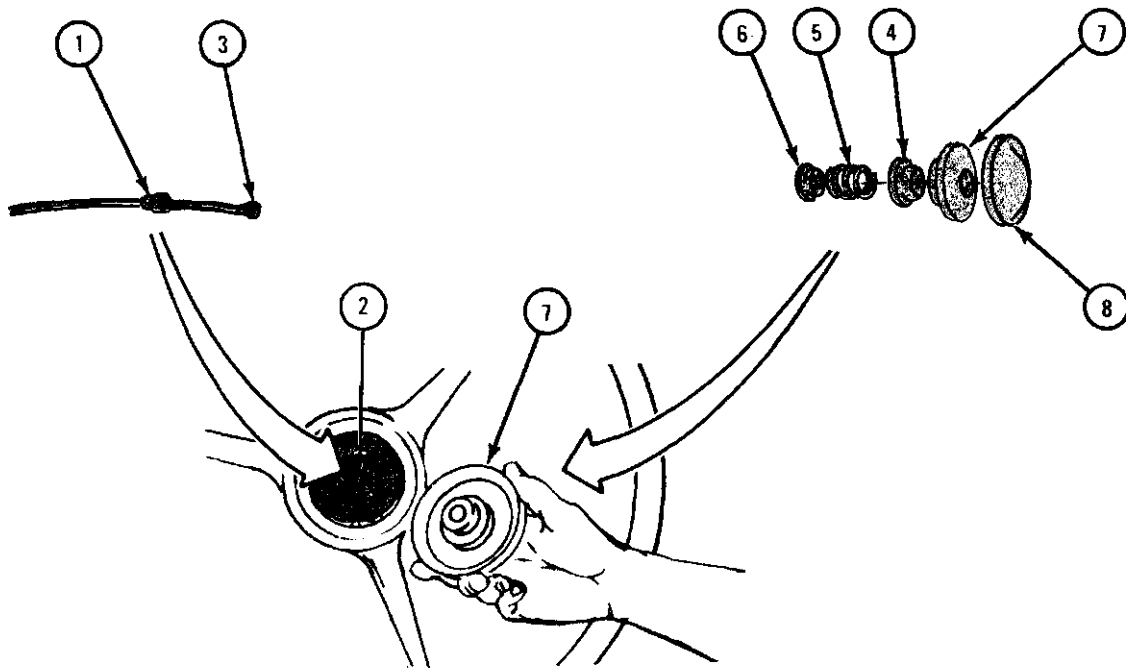

TA 047205

FRAME 4

1. Pull any slack in horn cable (1) out through hole in steering gear box (2).
2. Slide rubber bushing (3) up horn cable (1) and press firmly into hole in steering gear box (2).
3. Join plug (4) to connector (5).

NOTE

Follow-on Maintenance Action Required:

1. Reconnect battery ground cable. Refer to para 7-58.
2. Test horn by pressing horn button.
3. Close left side panel. Refer to TM 9-2320-209-10.

END OF TASK

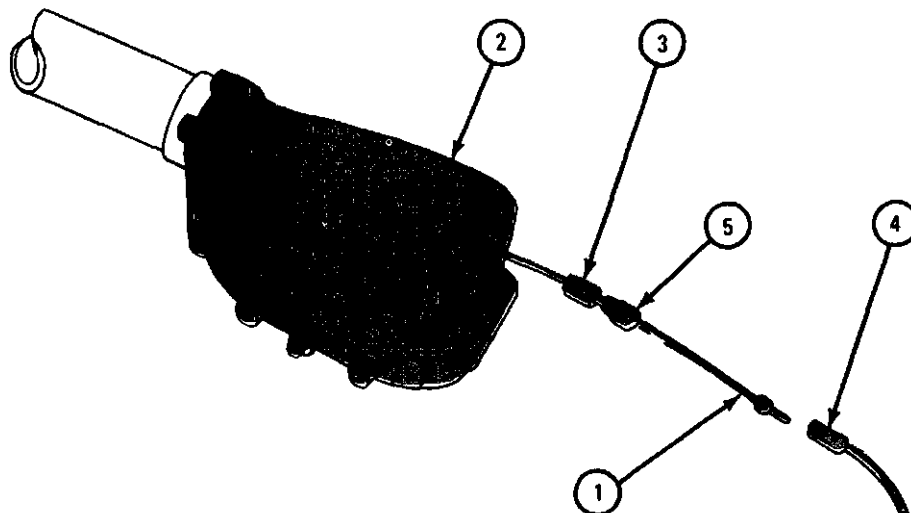

TA 047206

7-53. AIR HORN AND SOLENOID REMOVAL AND REPLACEMENT.

TOOLS: 7/16-inch wrench (2) 9/16-inch wrench
 5/8-inch wrench 11/16-inch wrench

SUPPLIES: None

PERSONNEL: One

EQUIPMENT CONDITION: Truck parked, engine off, handbrake set.

a. Preliminary Procedures.

- (1) Open hood and right side panel. Refer to TM 9-2320-209-10.
- (2) Vent air system pressure. Refer to Part 2, para 13-20.
- (3) Disconnect battery ground cable. Refer to para 7-58.

b. Removal.

FRAME 1

NOTE

Tag electrical connectors (1) before taking them off, to make sure they are put back in the right place.

1. Take two electrical connectors (1) off horn solenoid (2).
2. Using 5/8-inch wrench, unscrew coupling nut (3) and pull air tube (4) away from elbow (5).
3. Using 9/16-inch wrench, unscrew and take off elbow (5).

GO TO FRAME 2

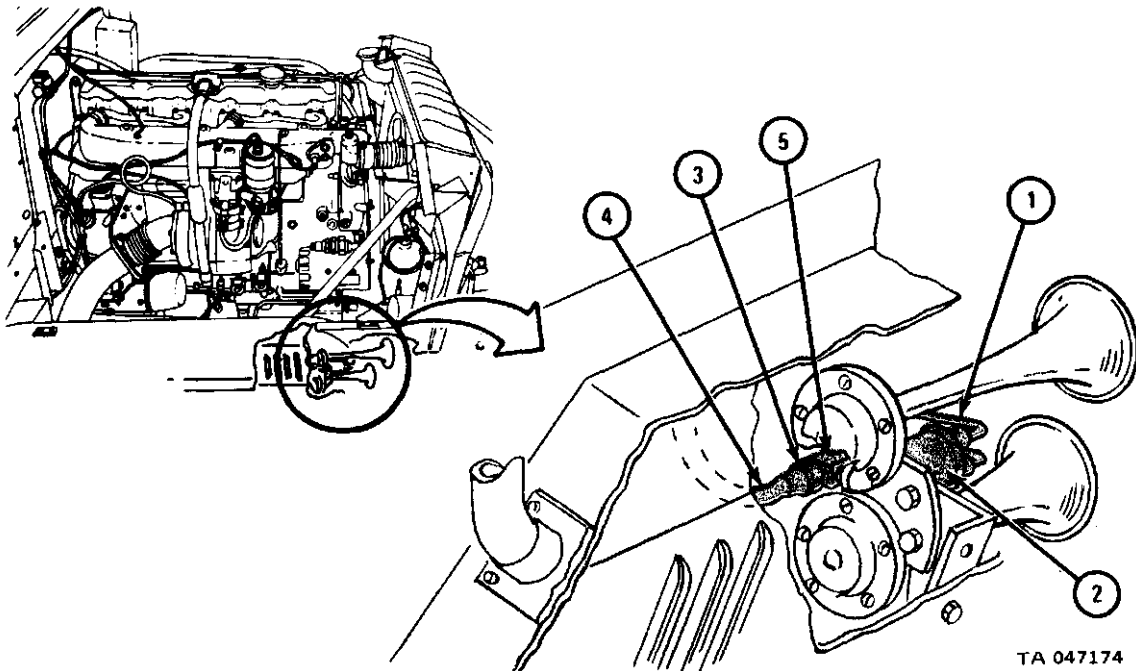

FRAME 3

1. Using 7/16-inch wrench, unscrew and take off two nuts (1) with lockwashers (2).
 2. Take out bolts (3) and lift air horn (4) away from bracket (5).
 3. Using 11/16-inch wrench, unscrew and take solenoid (6) from air horn (4).
- END OF TASK

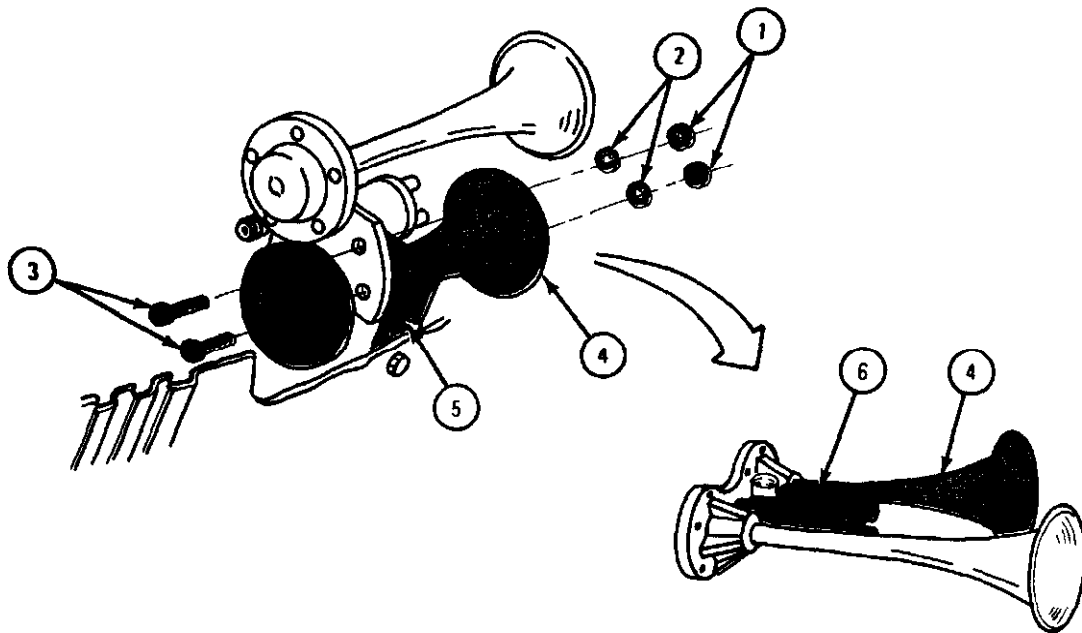

TA 047175

c. Replacement.

FRAME 1

1. Using 11/16-inch wrench, screw solenoid (1) onto nipple (2).
- GO TO FRAME 2

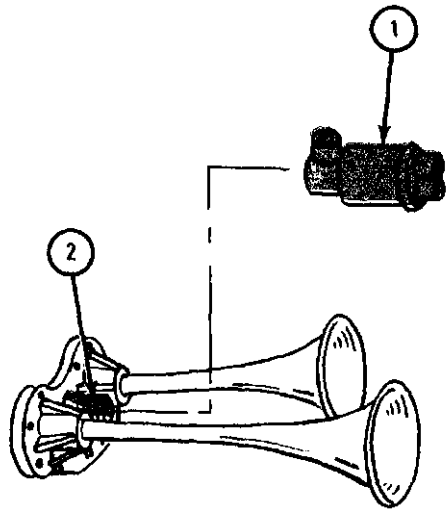

TA 047199

FRAME 2

1. Place air horn (1) on rear side of bracket (2). Aline holes and put in two bolts (3). Screw on two nuts (4) with lockwashers (5).
2. Using 7/16-inch wrenches, tighten two locknuts (4).

GO TO FRAME 3

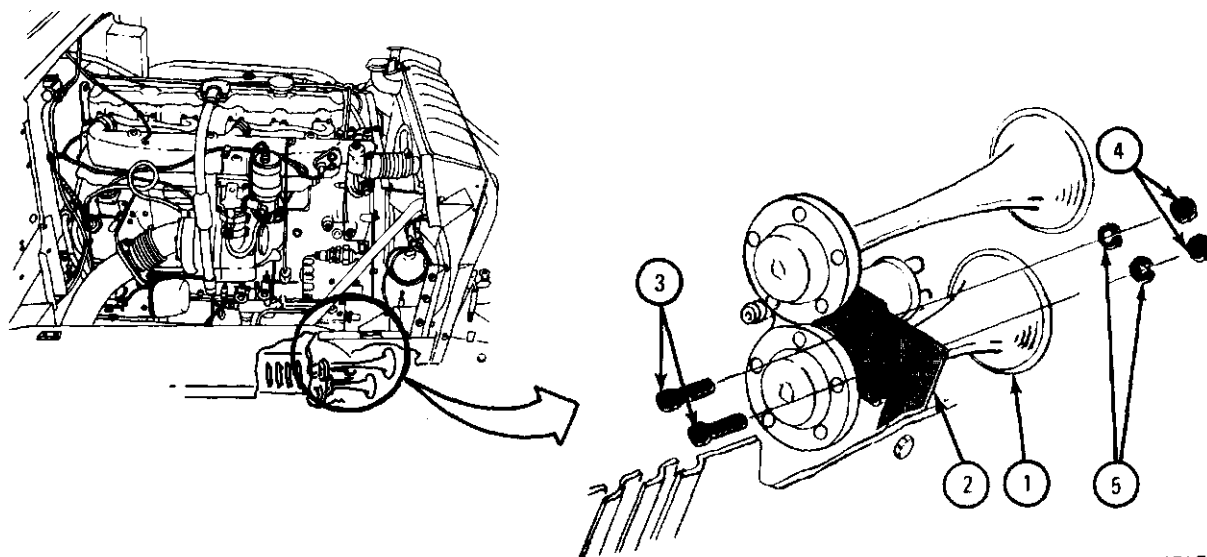

TA 047176

FRAME 3

1. Using 9/16-inch wrench, screw on and tighten elbow (1).
2. Using 5/8-inch wrench, screw on and tighten coupling nut (2) onto elbow (1).
3. Plug two cable connectors (3) into solenoid (4).

NOTE

Follow-on Maintenance Action Required:

1. Reconnect battery ground cable. Refer to para 7-58.
2. Run engine to build up air pressure in reservoirs and check air horn operation. Refer to TM 9-2320-209-10.
3. Close hood and right side panel. Refer to TM 9-2320-209-10.

END OF TASK

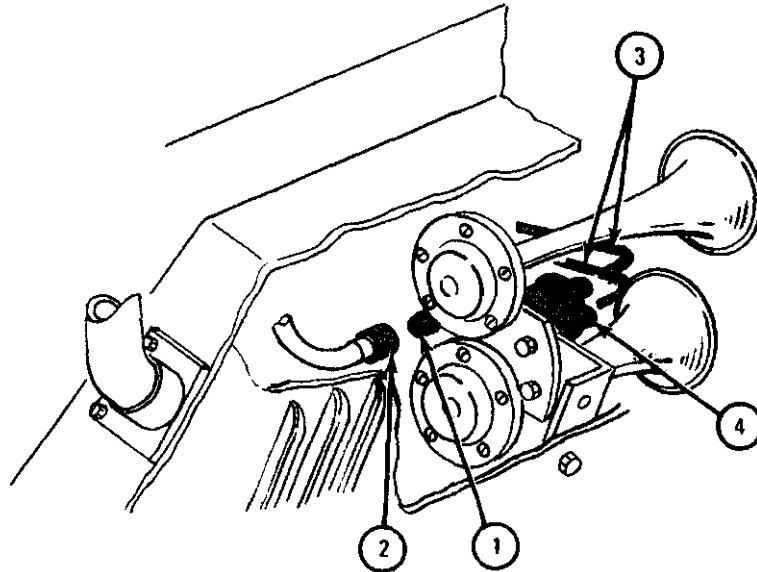

TA 047177

7-54. ELECTRIC HORN REMOVAL AND REPLACEMENT.

TOOLS: 7/16-inch wrench

SUPPLIES: Tags

PERSONNEL: One

EQUIPMENT CONDITION: Truck parked, engine off, handbrake set.

- a. Preliminary Procedure. Disconnect battery ground cable. Refer to para 7-58.
- b. Removal.

FRAME 1

NOTE

On trucks equipped with front winch, horn is mounted below headlamp.

- 1. Using 7/16-inch wrench, unscrew and take off two screws and washers (1).
- 2. Take horn assembly (2) far enough out of cutout in panel (3) to take off plugs (4 and 5).

NOTE

Tag electrical plugs before taking them off to be sure they are put back in the right place.

- 3. Take electrical plugs (4 and 5) off horn assembly (2).
- 4. Take away horn assembly (2).

END OF TASK

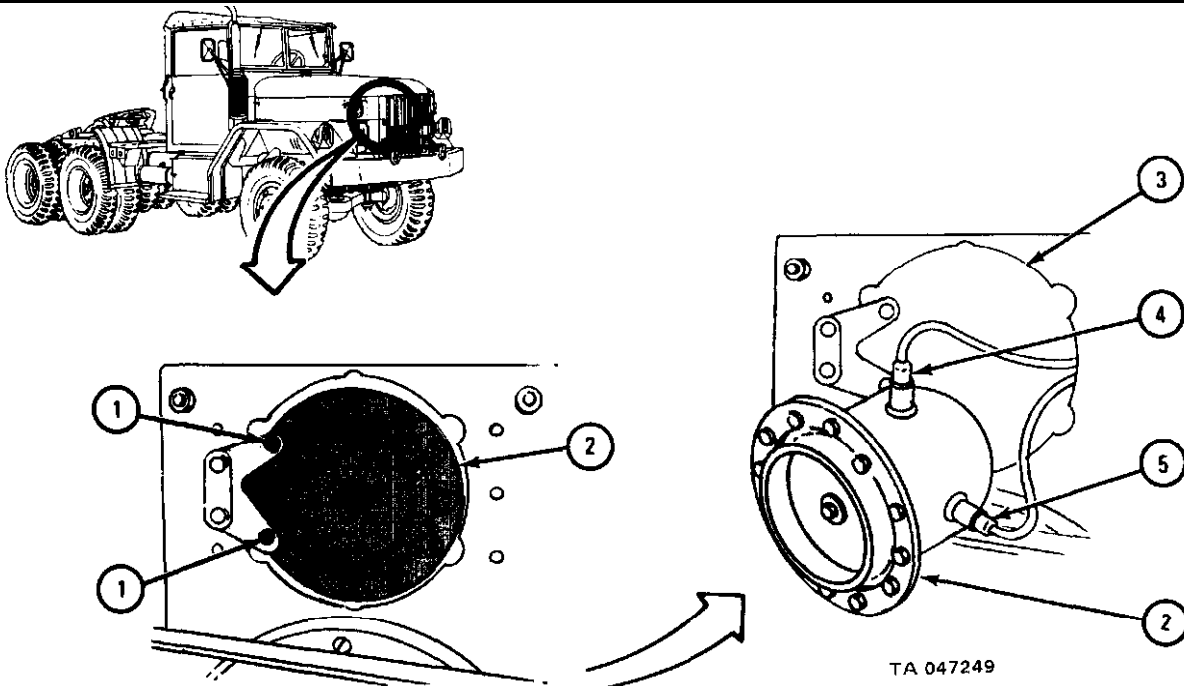

c. Replacement.

FRAME 1

1. Join two electrical plugs (1) to mating receptacles on horn (2).
2. Tilt horn (2) so it will pass through cutout in panel (3).
3. Put horn (2) in place on bracket (4).
4. Using 7/16-inch wrench, screw in and tighten two screws (5) with washers (6).

NOTE

Follow-on Maintenance Action Required:

1. Reconnect battery ground cable. Refer to para 7-58.
2. Test horn operation by pressing horn button.

END OF TASK

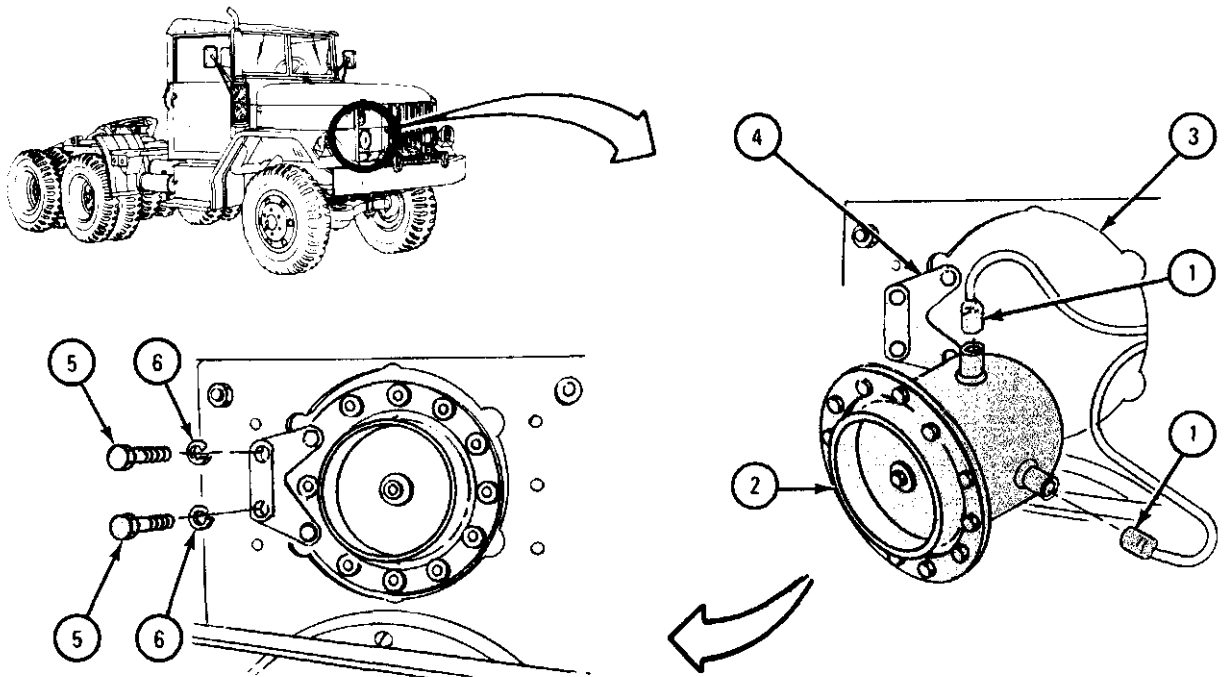

TA 047252

Section VIII. BATTERY SYSTEM

7-55. SERVICING THE BATTERIES.

TOOLS: AO DUO-CHECK, Rubber gloves
coolant and battery tester Eye shields
Wire brush Soaking tub
Battery filler, syringe

SUPPLIES: Distilled or clean water
Sodium bicarbonate, O-S-576
Lint-free cloth
Tissues or clean soft cloth

PERSONNEL: One

EQUIPMENT CONDITION: Truck parked, engine off, handbrake set.

- a. Preliminary Procedure. Remove batteries. Refer to para 7-56.
- b. Specific Gravity Check.
 - (1) Preliminary cleaning.

FRAME 1

1. Swing back plastic cover (1) of battery tester (2) all the way.
2. Using tissue, wipe bottom of plastic cover (3) and measuring window (4).
3. Close plastic cover (1).

END OF TASK

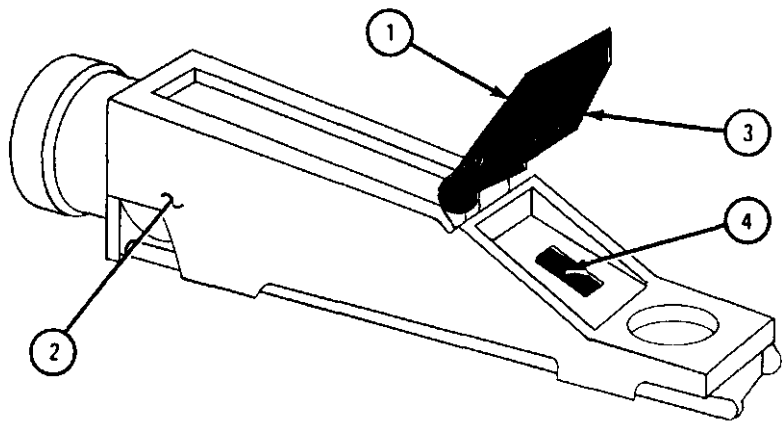

TA 114079

(2) Checkout procedure.

WARNING

Do not get electrolyte on personnel or equipment. Personnel may be badly burned, and equipment may be damaged.

Wear rubber gloves and eye shields while working with electrolyte to avoid serious injury from battery acid.

NOTE

Do this test before adding water to the battery. Do frames 1 and 2 for each battery cell.

FRAME 1

1. Unscrew and take off battery filler cap (1).
2. Take black dipstick (2) from dipstick retainer (3).
3. Put tip of dipstick (2) into battery cell (4).
4. Take out dipstick (2) from battery cell (4).
5. Using dipstick (2), place a few drops of electrolyte on measuring surface (5) through opening in plastic cover (6).

NOTE

Tilt battery tester so that electrolyte flows down the measuring surface.

GO TO FRAME 2

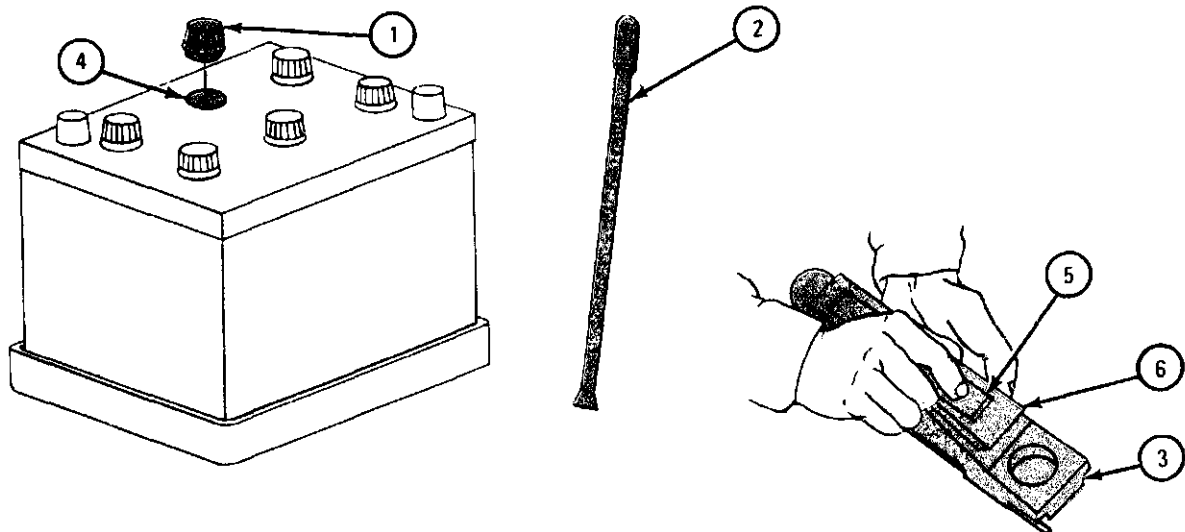

TA 049859

FRAME 2

1. Point coolant and battery tester (1) toward any light source. Look in eyepiece (2).
2. Read battery charge scale (3) on left side. Reading (4) is where dark shadow (5) meets light area (6).
3. Reading (4) should be in GOOD range (1.250 to 1.300). If specific gravity is below 1.225, replace battery with a fully charged battery if recharging is not possible.
4. Using battery filler syringe, add distilled water if available or clean water as needed to bring electrolyte to needed level, 3/4-inch above plates.
5. Screw on and tighten battery filler cap (7).
6. Clean and dry all parts of the coolant and battery tester (1).

END OF TASK

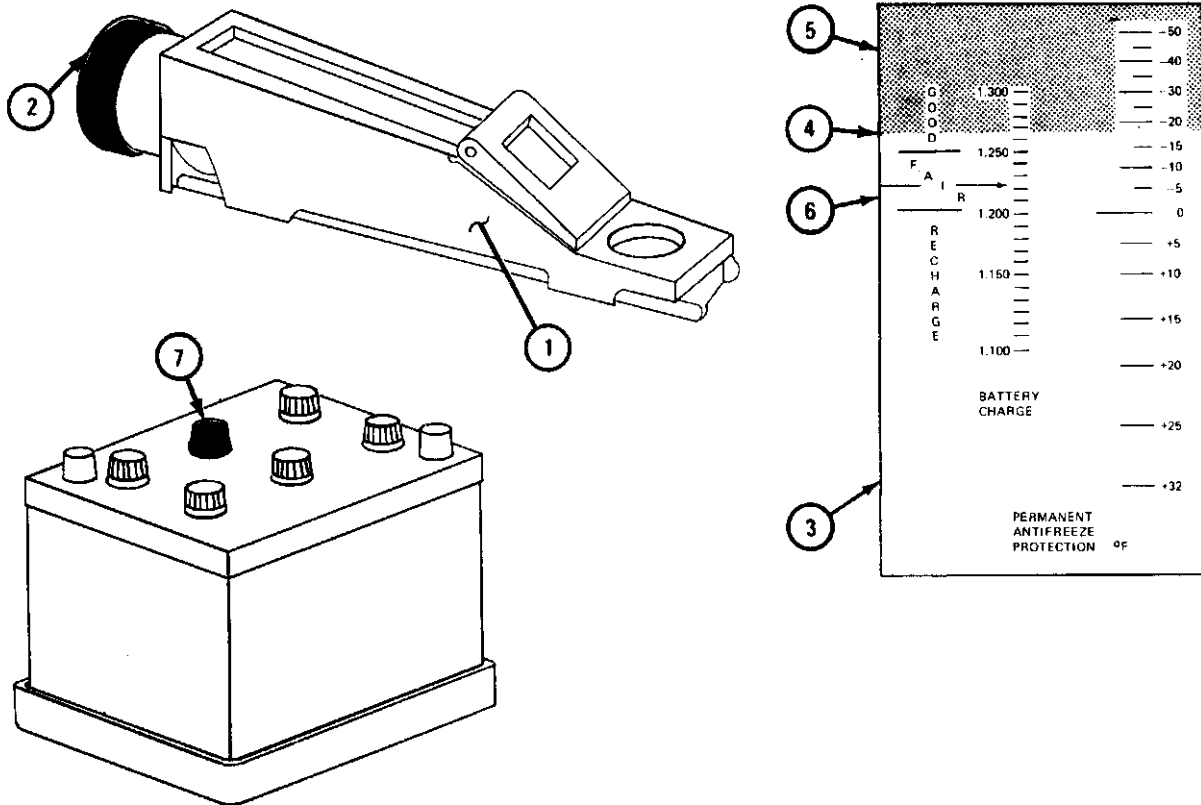

TA 049861

c. Cleaning the Batteries.

FRAME 1

1. Using 1/2 pound of bicarbonate of soda to one gallon of water, mix a bicarbonate of soda solution.
2. Using bristle brush and soda solution, scrub tops of batteries (1) and battery posts (2).
3. After foaming stops, rinse tops of batteries (1) with clean water.
4. Using lint-free cloth, dry off batteries (1).

GO TO FRAME 2

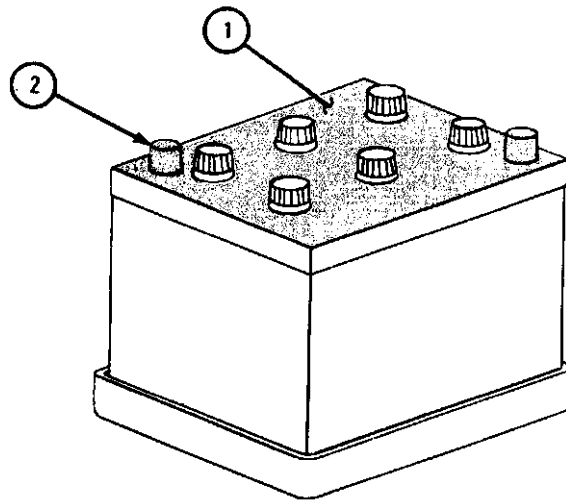

TA 049865

FRAME 2

1. Using wire brush, scrub battery hold down bolts (1) and battery retainer (2) to take off rust or corrosion.
2. Soak battery hold down bolts (1) and retainer (2) in tub filled with sodium bicarbonate solution. After foaming stops, rinse in clean water,
3. Using wire brush, scrub battery box (3) to take off rust or corrosion.
4. Wash battery box (3) in sodium bicarbonate solution. After foaming stops, rinse in clean water.
5. Using lint-free cloth, dry battery hold down bolts (1), battery retainer (2), and battery box (3).

NOTE

Follow-on Maintenance Action Required:
Replace batteries. Refer to para 7-56.

END OF TASK

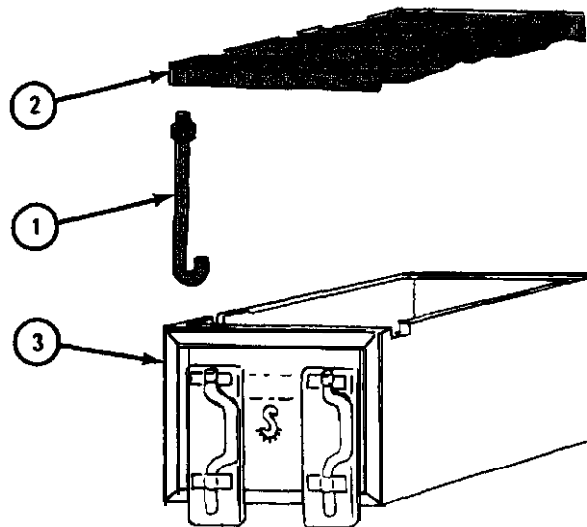

TA 049868

7-56. STORAGE BATTERIES REMOVAL AND REPLACEMENT.

TOOLS : 1/2-inch wrench
 9/16-inch wrench

SUPPLIES: Sodium bicarbonate, O-S-576

PERSONNEL: One

EQUIPMENT CONDITION: Truck parked, engine off, handbrake set.

a. Removal.

WARNING

Battery electrolyte will burn wood, clothing, and skin. Wash spills immediately with flowing water. Use paste solution of sodium bicarbonate and water to apply to affected area.

FRAME 1

1. Open battery compartment door (1).
2. Loosen two thumbscrews (2) and push clamps (3) down to clear battery box (4).
3. Pull battery box (4) out onto running board (5).

GO TO FRAME 2

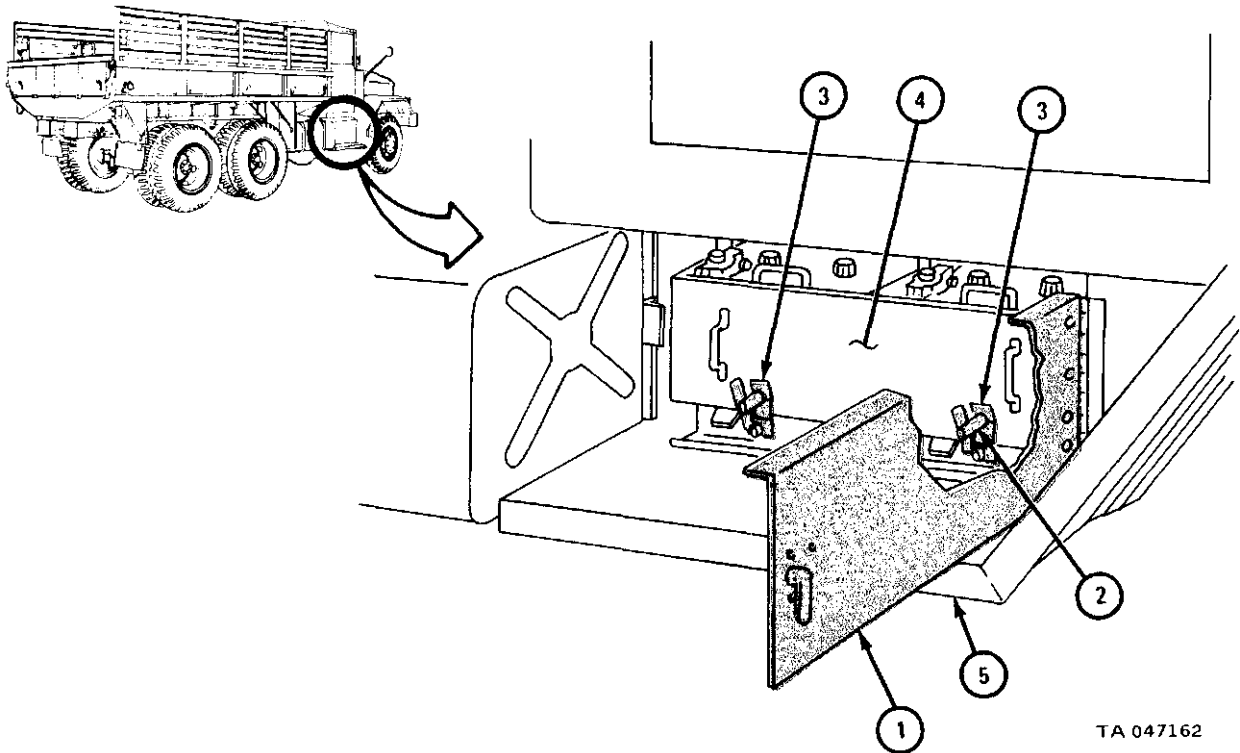

TA 047162

FRAME 2

CAUTION

Always take off ground terminal first or electrical damage may occur.

1. Using 1/2-inch wrench, loosen nut (1) and take off battery ground (-) terminal (2).
2. Using 1/2-inch wrench, loosen nut (3) and take off positive (+) terminal (4).
3. Using 1/2-inch wrench, loosen nut (5) and take off positive (+) terminal (6).
4. Using 9/16-inch wrench, loosen nut (7) and lift off jumper cable (8).

GO TO FRAME 3

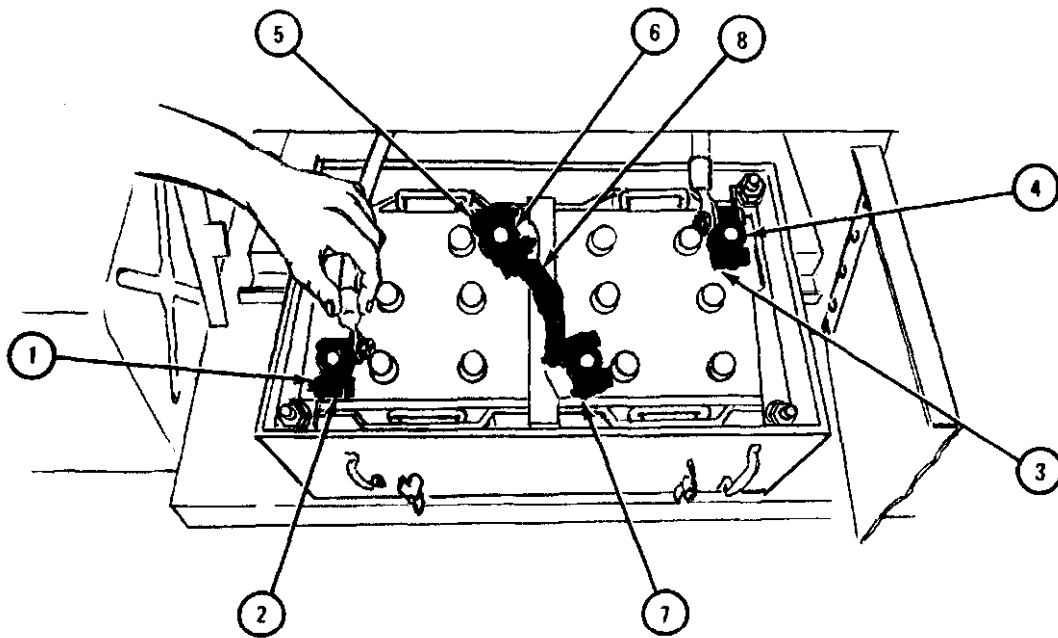

TA 047163

FRAME 3

1. Using 9/16-inch wrench, unscrew and take off nut and lockwasher (1).
2. Using 9/16-inch wrench, loosen four nuts (2) on clamp bolts (3).

WARNING

Be very careful not to short positive and negative battery posts against retainer (4). This could cause retainer to melt and battery to explode. Explosion could cause injury to personnel.

3. Push four clamp bolts (3) out of slots in battery retainer (4). Lift off battery retainer.
4. Lift out two batteries (5).

END OF TASK

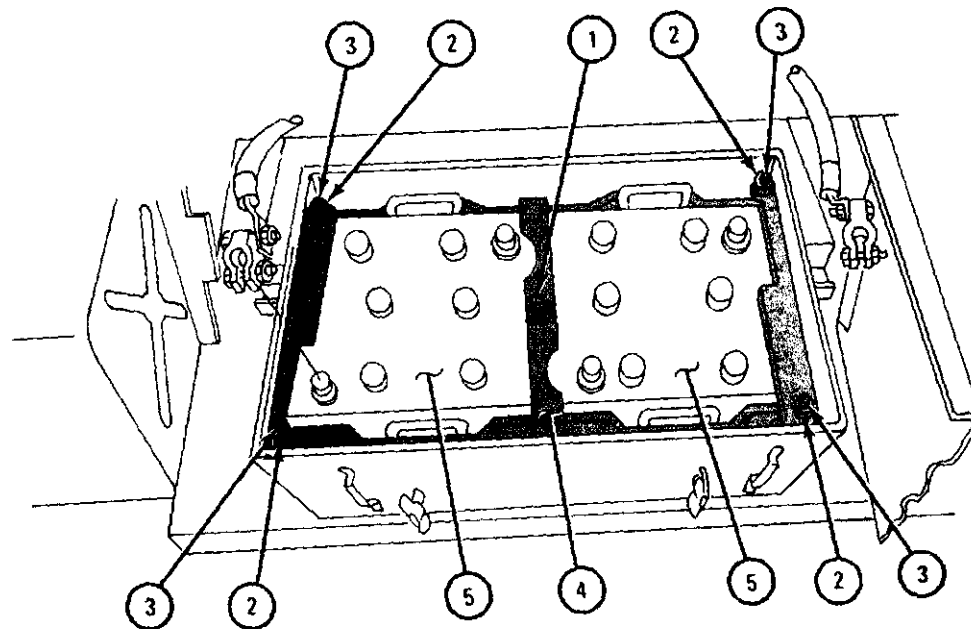

TA 047164

b. Replacement.

FRAME 1

1. Make sure battery box (1) is placed on running board (2) as shown.
2. Place five clamp bolts (3) as shown.
3. Lift batteries (4) into box (1) with negative (-) terminal (5) of each battery in position shown.

GO TO FRAME 2

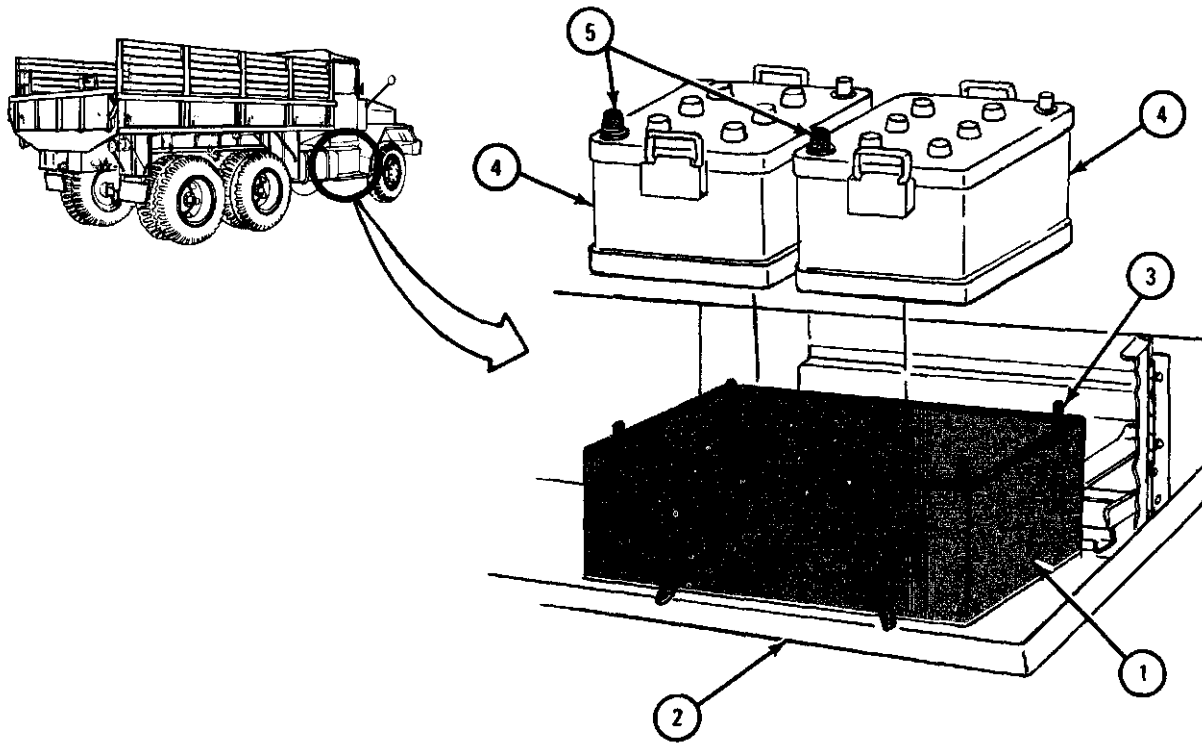

TA 047165

FRAME 2

WARNING

Be very careful not to short positive and negative battery posts against retainer. This could cause retainer to melt and battery to explode. Explosion could cause injury to personnel.

1. Line up center hole and four slots in battery retainer (1) with five clamp bolts (2).
2. Place battery retainer over batteries (3) and five clamp bolts (2).
3. Screw five nuts (4) with lockwashers (5) on five clamp bolts (2). Using 9/16-inch wrench, evenly tighten nuts.

GO TO FRAME 3

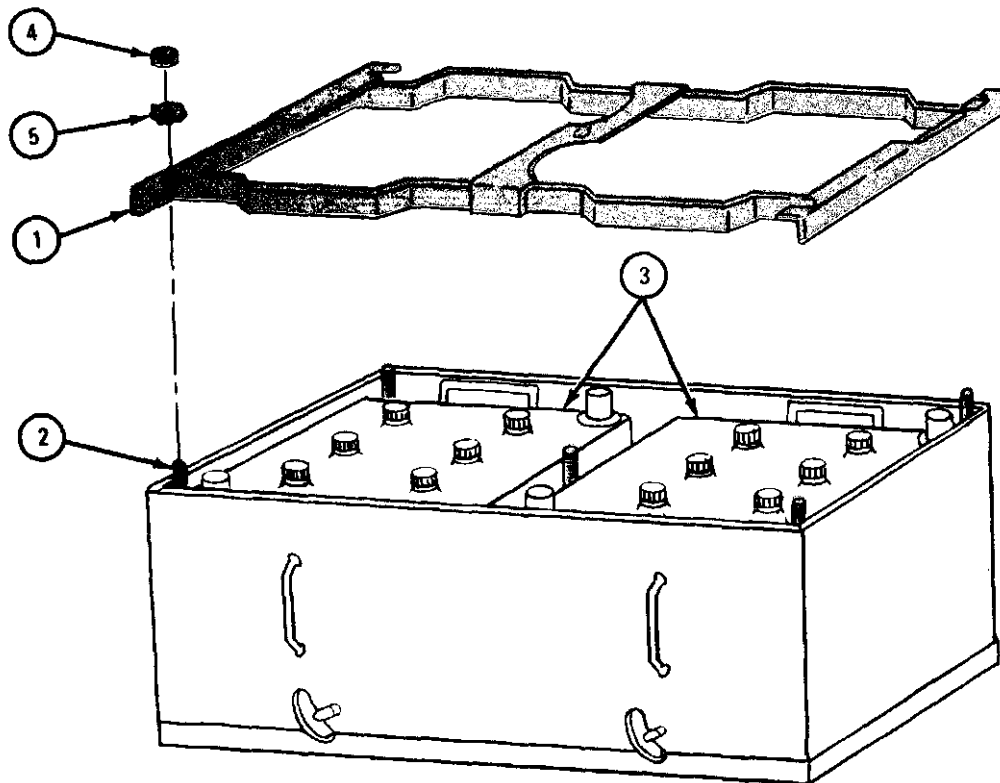

TA 047166

FRAME 3

1. Put positive (+) terminal (1) on positive (+) post (2) of forward battery. Using 1/2-inch wrench, tighten nut (3).
2. Put jumper cable negative (-) terminal (4) on negative (-) post (5) of forward battery. Using 1/2-inch wrench, tighten nut (6).

GO TO FRAME 4

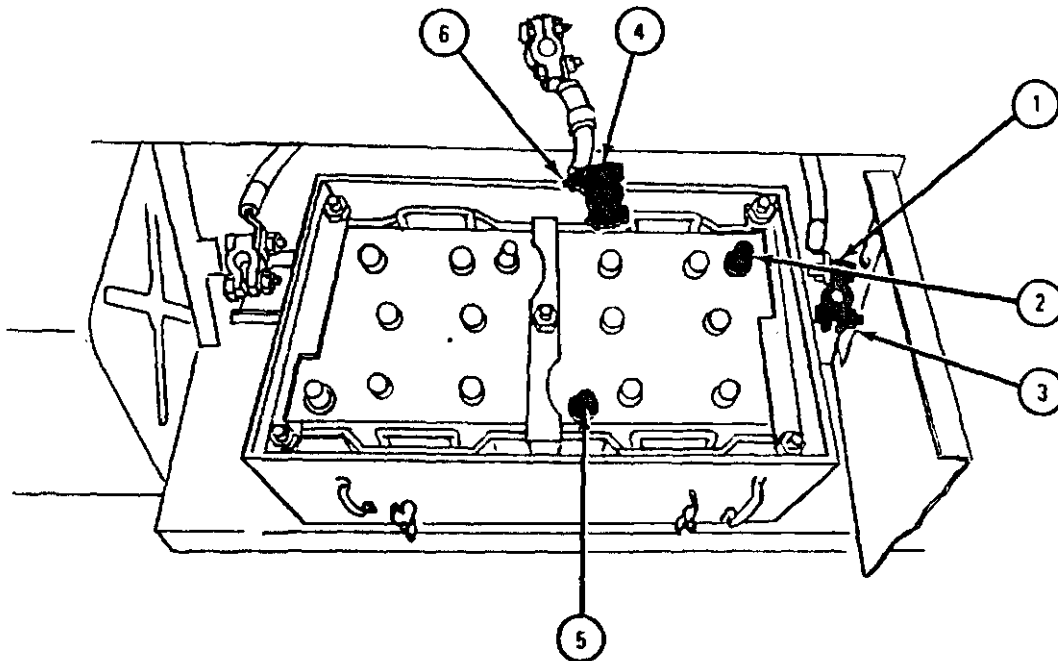

TA 047167

FRAME 4

1. Put jumper cable positive (+) terminal (1) on positive (+) post (2) of rear battery. Using 1/2-inch wrench, tighten nut (3).
2. Put ground (-) cable terminal (4) on negative (-) post (5) of rear battery. Using 1/2-inch wrench, tighten nut (6).

GO TO FRAME 5

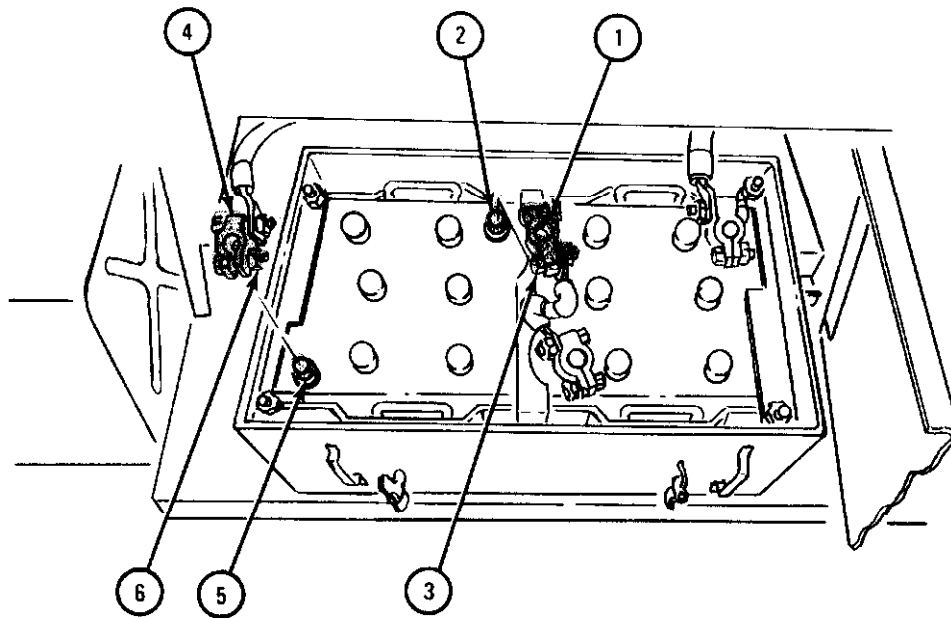

TA 047168

FRAME 5

1. Push battery box (1) off running board (2) into battery compartment.
2. Latch two clamps (3) on thumbscrews (4) and tighten thumbscrews.
3. Close battery compartment door (5).

END OF TASK

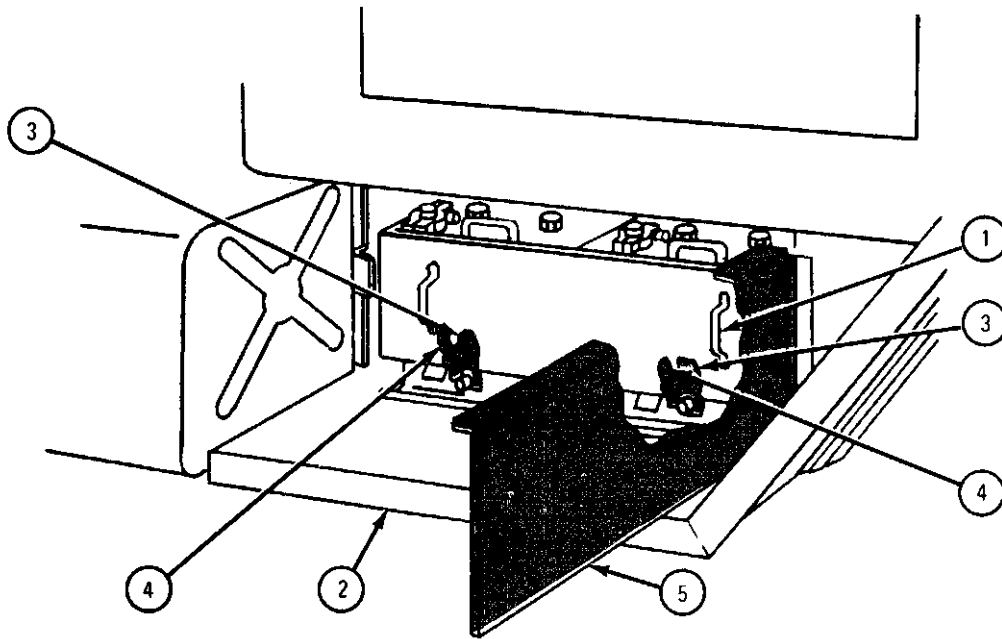

TA 047169

7-57. GROUND STRAPS REMOVAL AND REPLACEMENT.

TOOLS: 9/16-inch wrench
 1/2-inch wrench
 7/16-inch wrench

SUPPLIES: None

PERSONNEL: One

EQUIPMENT CONDITION: Truck parked, engine off, handbrake set.

a. Removal.

(1) Front ground strap.

FRAME 1

1. Using 9/16-inch wrench, unscrew and take off locknut (1) and washer (2).
 2. Using 7/16-inch wrench, loosen capscrew (3). Take off ground strap (4).
- END OF TASK

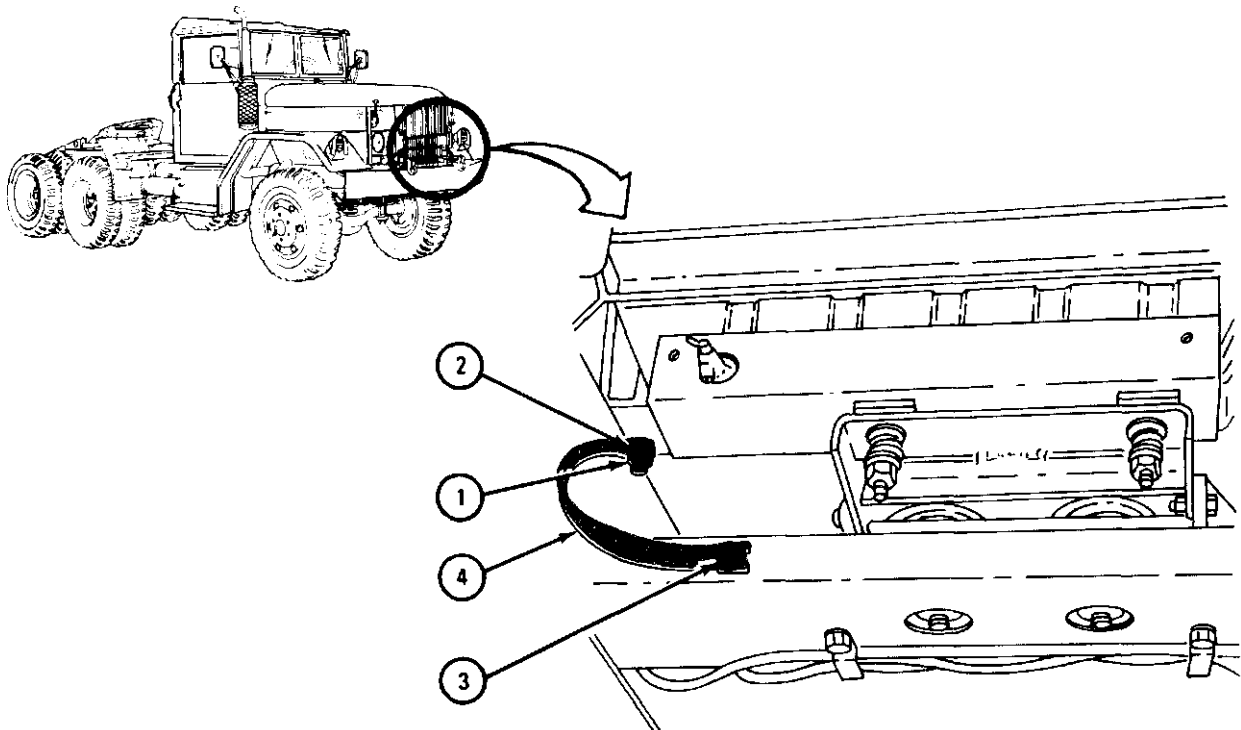

TA 080826

(2) Lower rear ground strap.

FRAME 1

1. Using 9/16-inch wrench, unscrew and take out capscrew and washer (1).
2. Using 1/2-inch wrench, unscrew and takeout capscrew and washer (2).
Take off ground strap (3).

END OF TASK

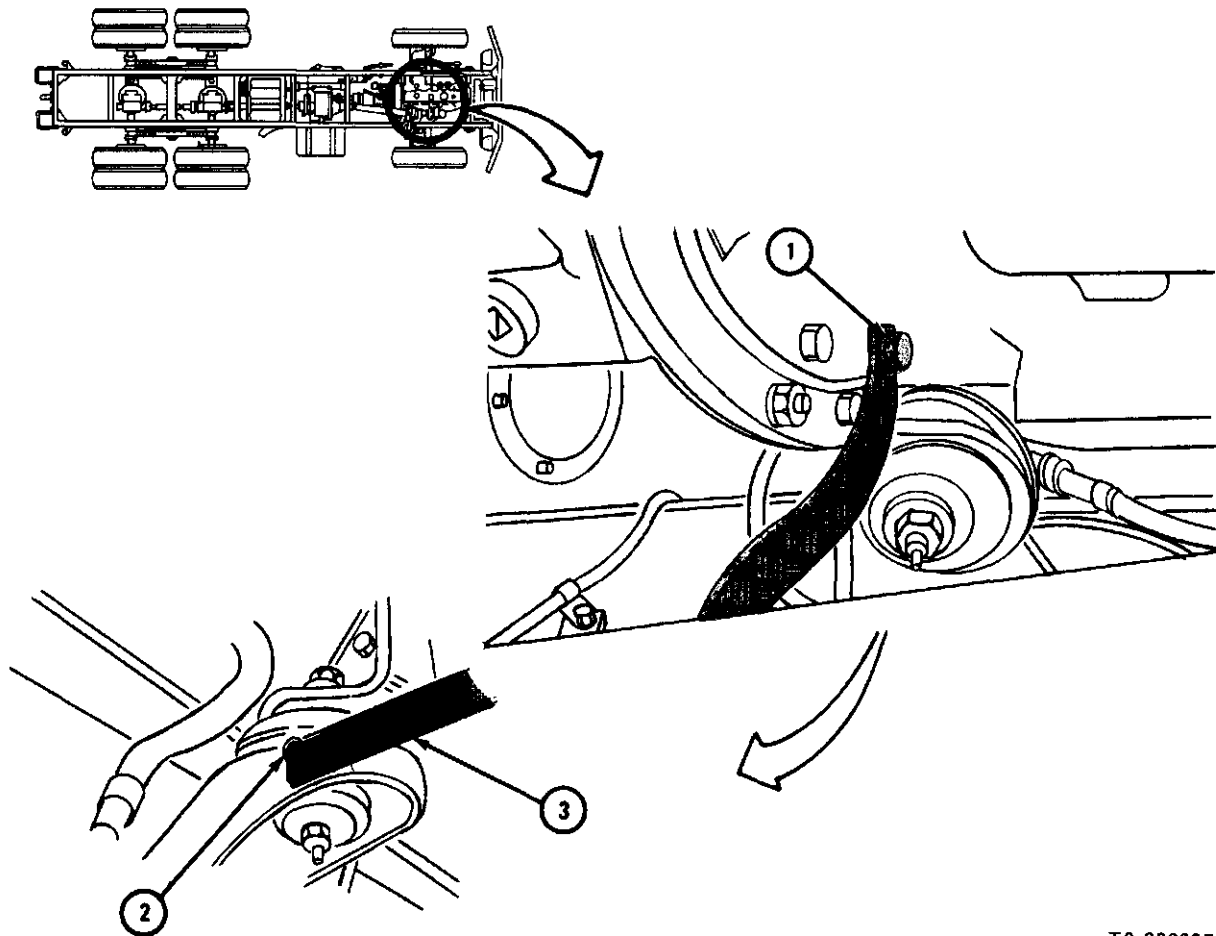

TA 080997

(3) Upper rear ground strap.

FRAME 1

1. Open hood and left side panel. Refer to TM 9-2320-209-10.
2. Using 9/16-inch wrench, unscrew and take off locknut (1) and washer (2).
3. Using 9/16-inch wrench, loosen capscrew (3). Pull ground strap (4) out of capscrew.
4. Take ground strap (4) off stud (5).

END OF TASK

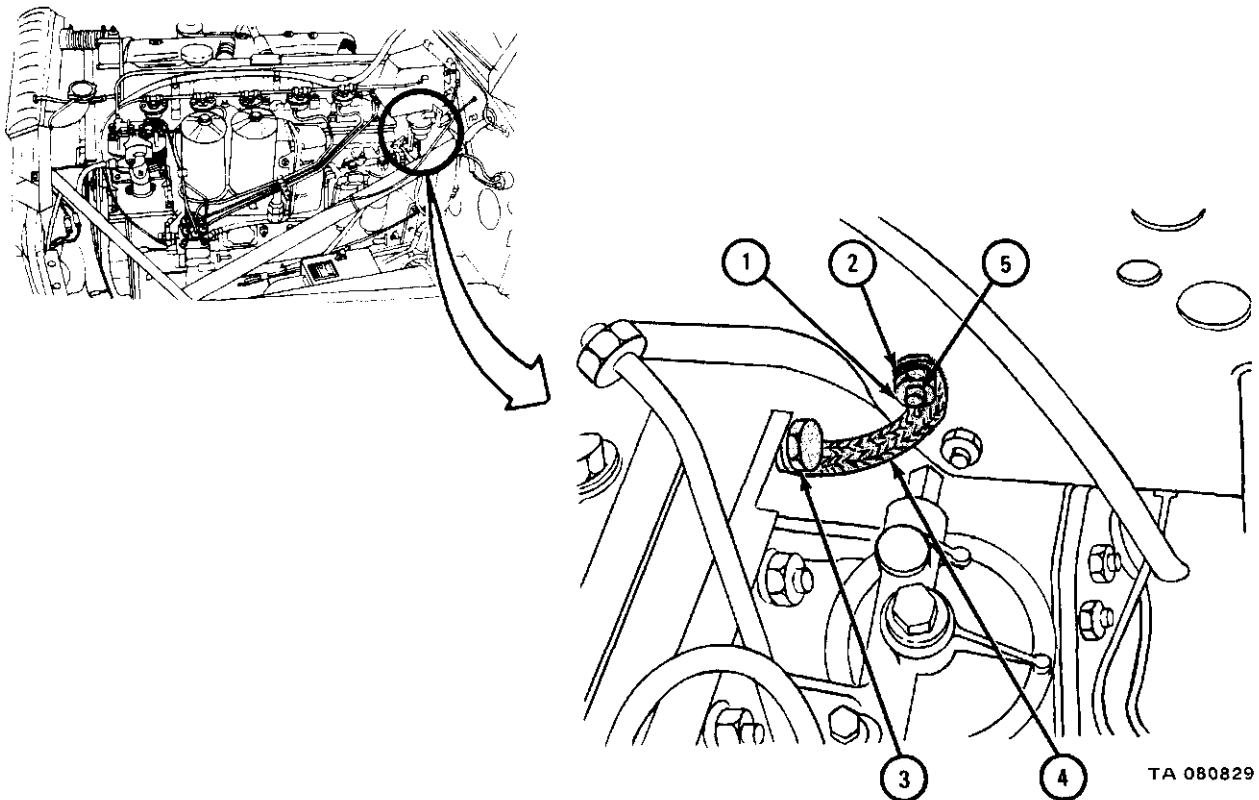

b. Replacement.

(1) Front ground strap.

FRAME 1

1. Put ground strap (1) on stud (2). Using 9/16-inch wrench, screw on and tighten washer (3) and locknut (4).
2. Slide open end of ground strap (1) between washer (5) and crossmember (6).
3. Using 7/16-inch wrench, tighten capscrew (7).

END OF TASK

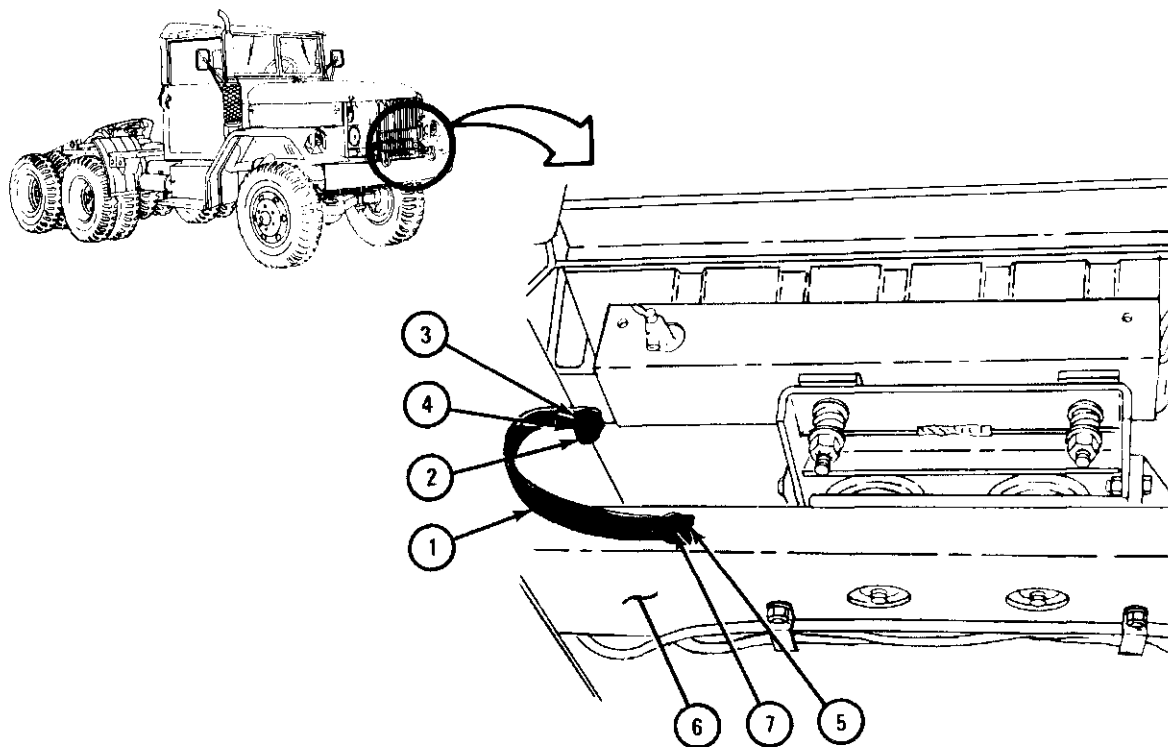

TA 080827

(2) Lower rear ground strap.

FRAME 1

1. Aline screw hole in ground strap (1) with screw hole in bell housing (2). Using 9/16-inch wrench, screw in and tighten capscrew and washer (3).
2. Aline screw hole in other end of group strap (1) with screw hole in engine mount bracket (4). Using 1/2-inch wrench, screw in and tighten capscrew and washer (5).

END OF TASK

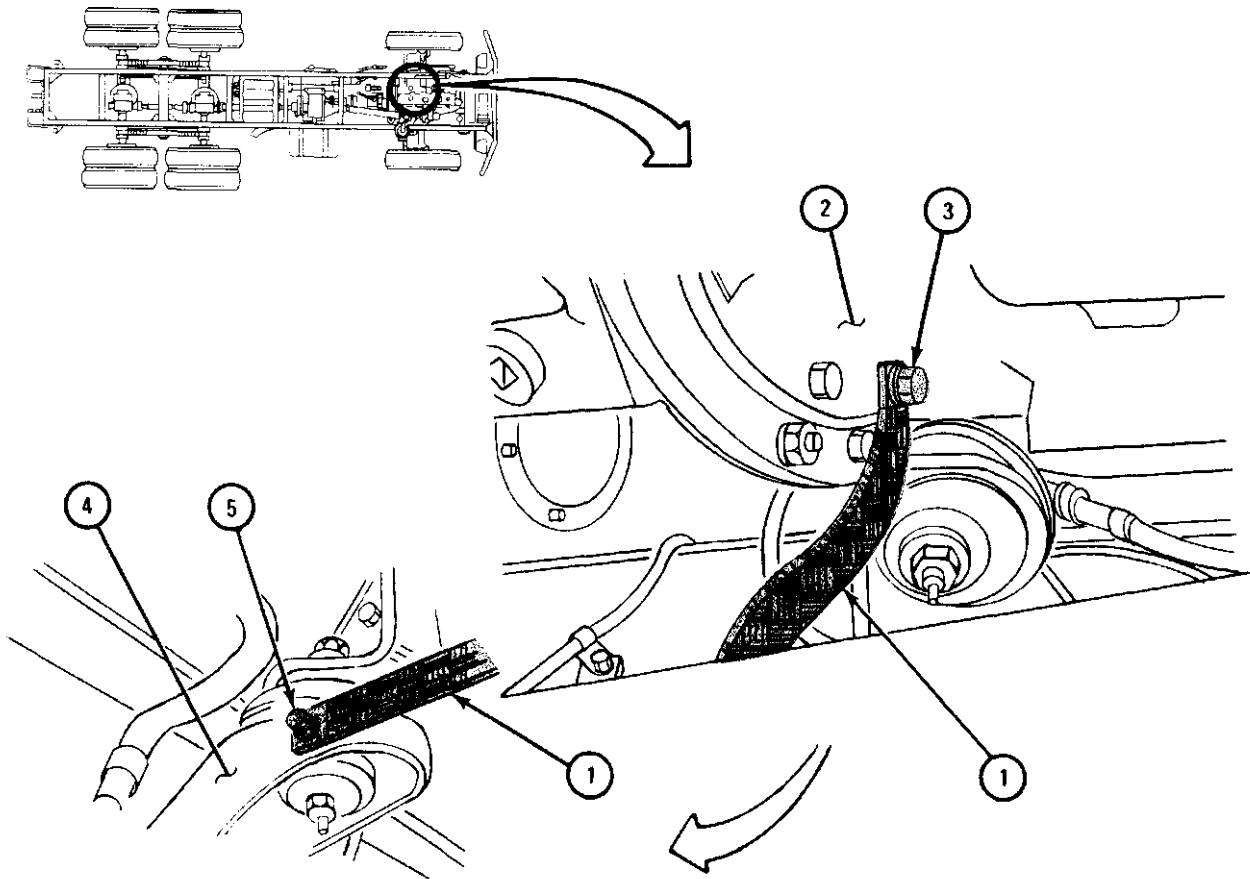

TA 080828

(3) Upper rear ground strap.

FRAME 1

1. Put open end of ground strap (1) between washer (2) and engine (3). Put other end of ground strap over stud (4).
2. Using 9/16-inch wrench, tighten capscrew (5).
3. Using 9/16-inch wrench, screw on and tighten washer (6) and locknut (7).

NOTE

Follow-on Maintenance Action Required:

Close hood and left side panel. Refer to TM 9-2320-209-10.

END OF TASK

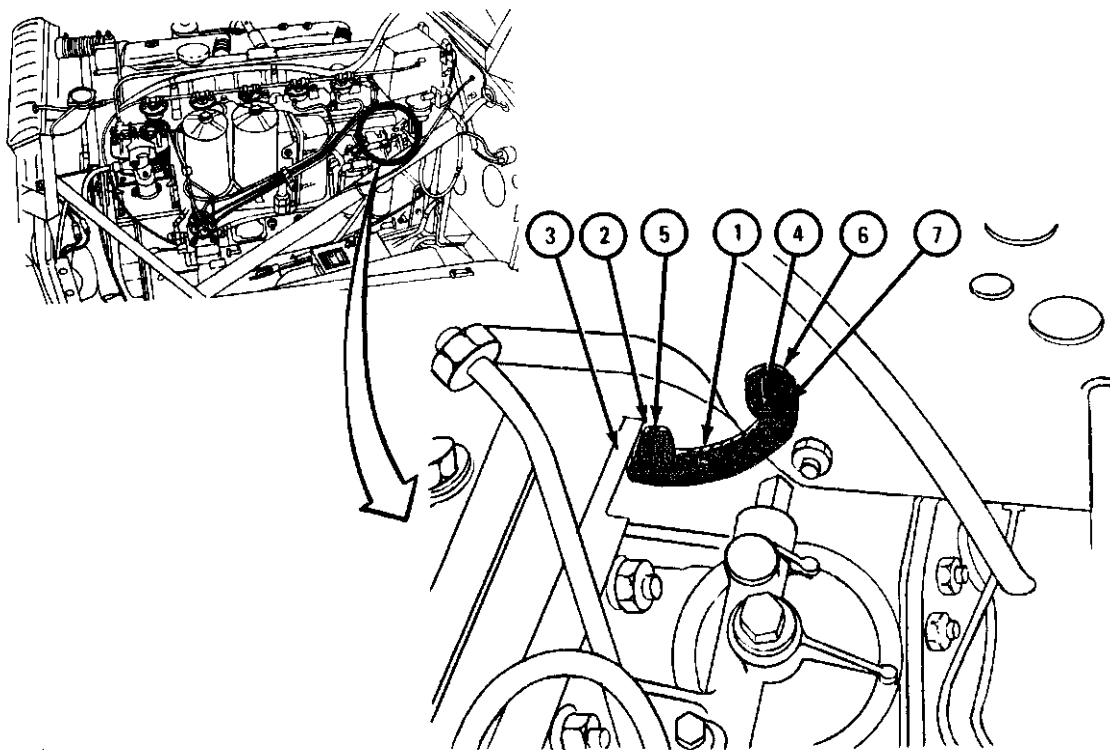

TA 080830

7-58. BATTERY GROUND CABLE.

TOOLS: 1/2-inch wrench
 Battery terminal lifter

SUPPLIES: None

PERSONNEL: One

EQUIPMENT CONDITION: Truck parked, engine off, handbrake set.

a. Disconnect.

FRAME 1

1. Open battery compartment door (1).
2. Loosen two thumbscrews (2) and push clamps (3) down to clear battery box (4).
3. Pull battery box (4) out onto running board (5).

GO TO FRAME 2

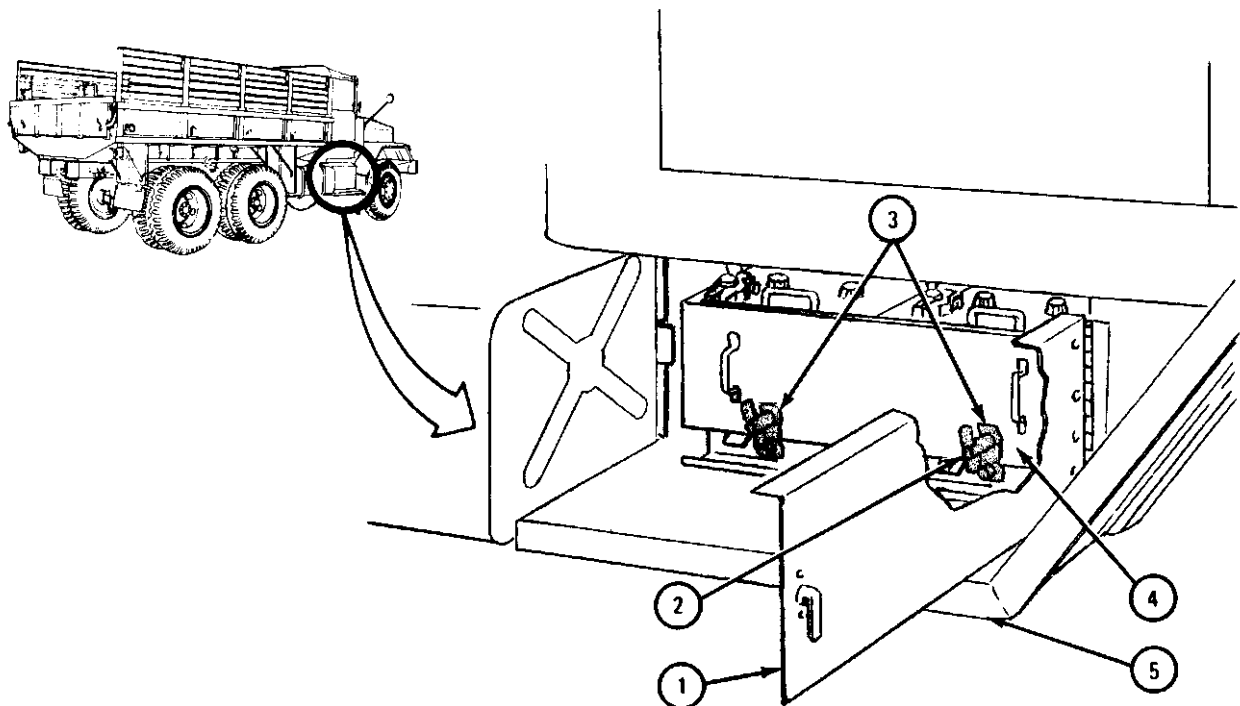

TA 101578

FRAME 2

WARNING

Do not let tool touch positive terminal on battery and truck or there will be a direct short, and arcing and tool will heat. This could cause equipment damage and injury to personnel.

1. Using 1/2-inch wrench, loosen nut (1) and using terminal lifter, take off battery ground terminal (2).
2. Move battery ground cable (3) out of the way so battery ground terminal (2) will not touch either of two batteries (4).

END OF TASK

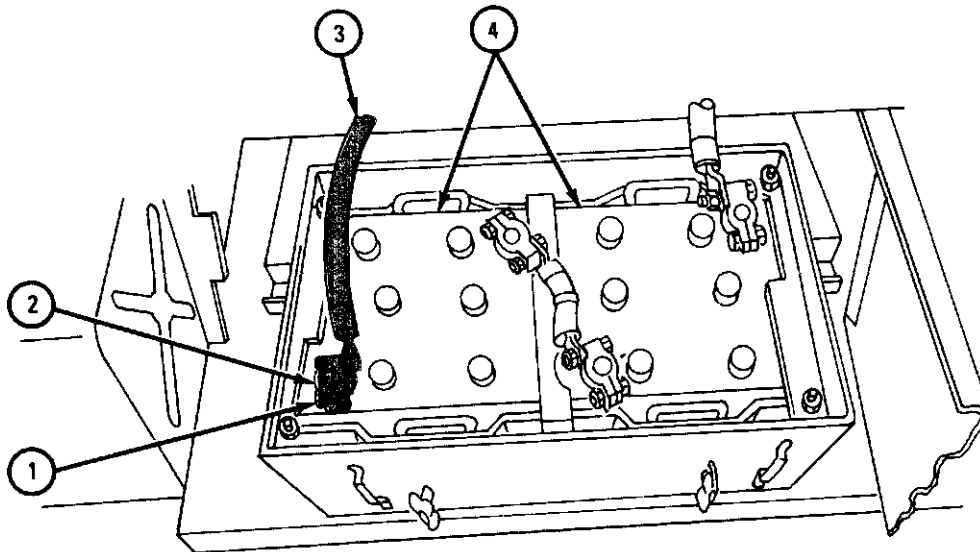

TA 101579

b. Reconnect.

FRAME 1

WARNING

Do not let tool touch positive terminal on battery and truck or there will be a direct short, and arcing and tool will heat. This could cause equipment damage and injury to personnel.

1. Put ground cable terminal (1) on negative post (2) of rear battery (3). Using 1/2-inch wrench, tighten nut (4).

GO TO FRAME 2

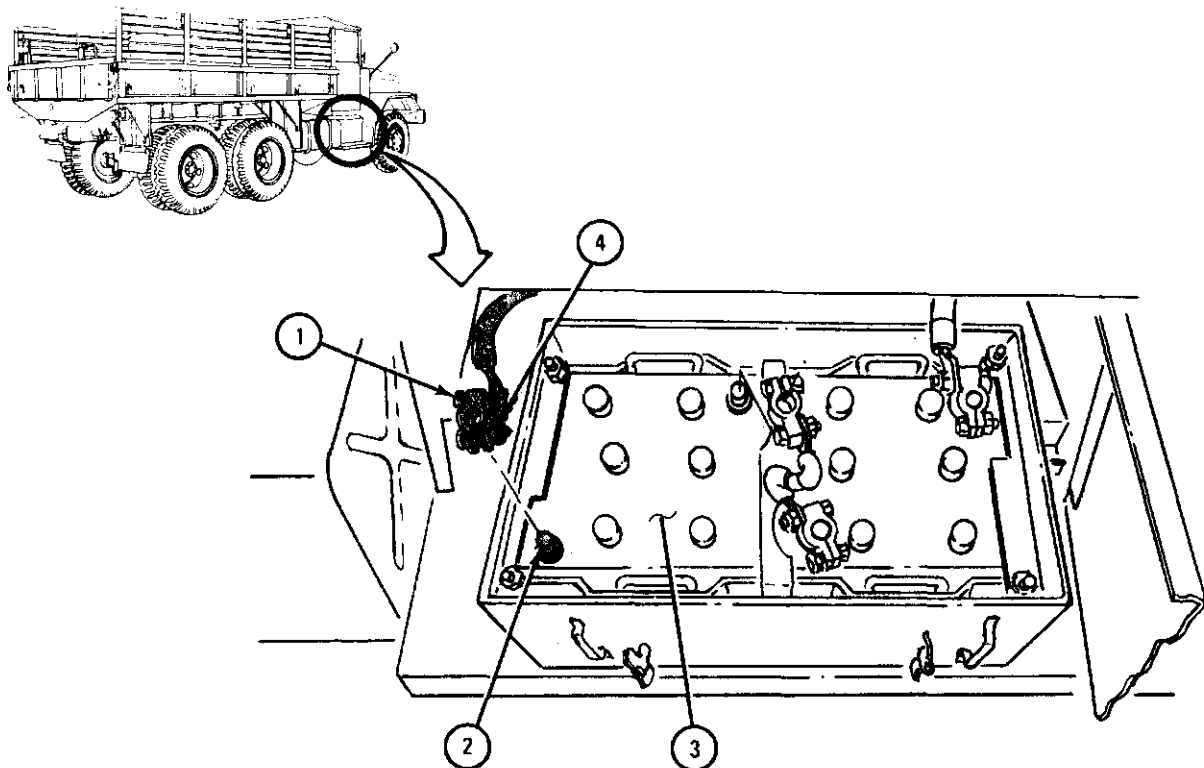

TA 080951

FRAME 2

1. Push battery box (1) off running board (2) into battery compartment.
2. Latch two clamps (3) on thumbscrews (4) and tighten thumbscrews.
3. Close battery compartment door (5).

END OF TASK

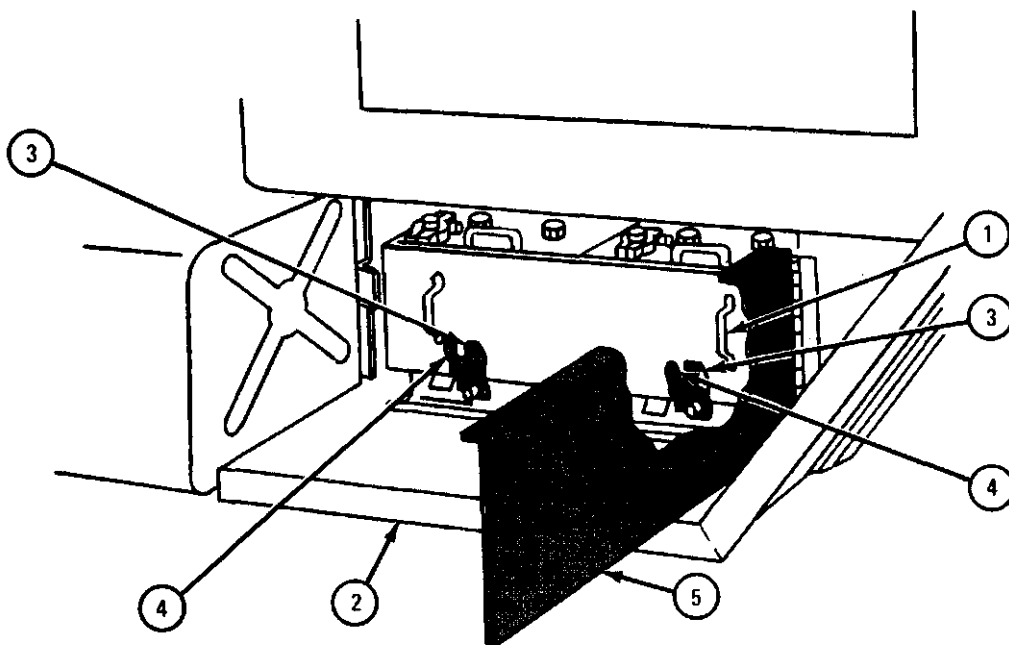

TA 047169

Section IX. CHASSIS HARNESS

7-59. GENERATOR-TO-REGULATOR HARNESS REMOVAL, REPAIR, AND REPLACEMENT (TRUCKS WITH ENGINES LDS 427-2, LD 465-1, AND LDT 465-IC).

TOOLS: Spanner wrench
Soldering iron

SUPPLIES: Sandpaper or crocus cloth
Electric insulating tape, MIL-T-50886

PERSONNEL: One

EQUIPMENT CONDITION: Truck parked, engine off, handbrake set.

- a. Preliminary Procedure. Disconnect battery ground cable. Refer to para 7-58.
- b. Removal.

FRAME 1

NOTE

Note the way generator-to-regulator harness is routed so that it can be put back the same way.

1. Using spanner wrench, unscrew and take off generator-to-regulator harness connector (1) from regulator (2).
2. Using spanner wrench, unscrew and take off generator-to-regulator harness connector (3) from generator (4).
3. Take out generator-to-regulator harness (5).

END OF TASK

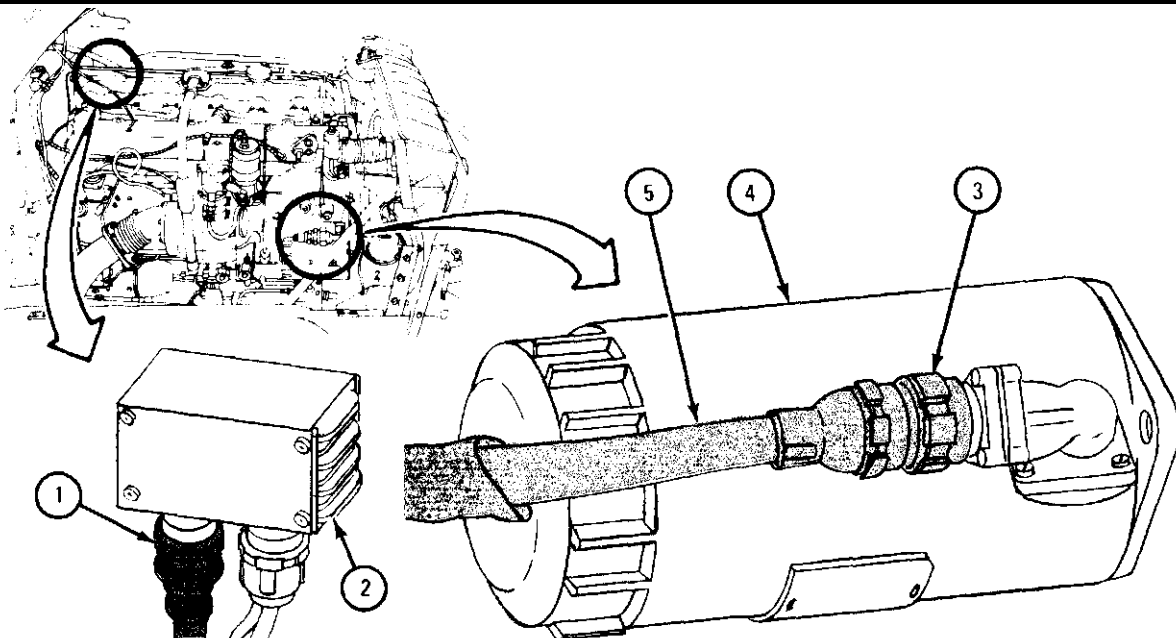

TA 083345

c. Repair.

FRAME 1

1. Take off all loose outer covering (1). Clean conduit (2) and take off as much of covering as you can.
2. Wrap cable with insulating tape from one end to the other. Be sure to have a lap joint one half the width of the tape. Tie loose end of tape at the connectors (3).
3. Resolder any wires which have been broken or pulled off connector terminal (4).
4. Clean corrosion from pin terminal and pin socket connector fittings (5 and 6) with sandpaper or crocus cloth.

END OF TASK

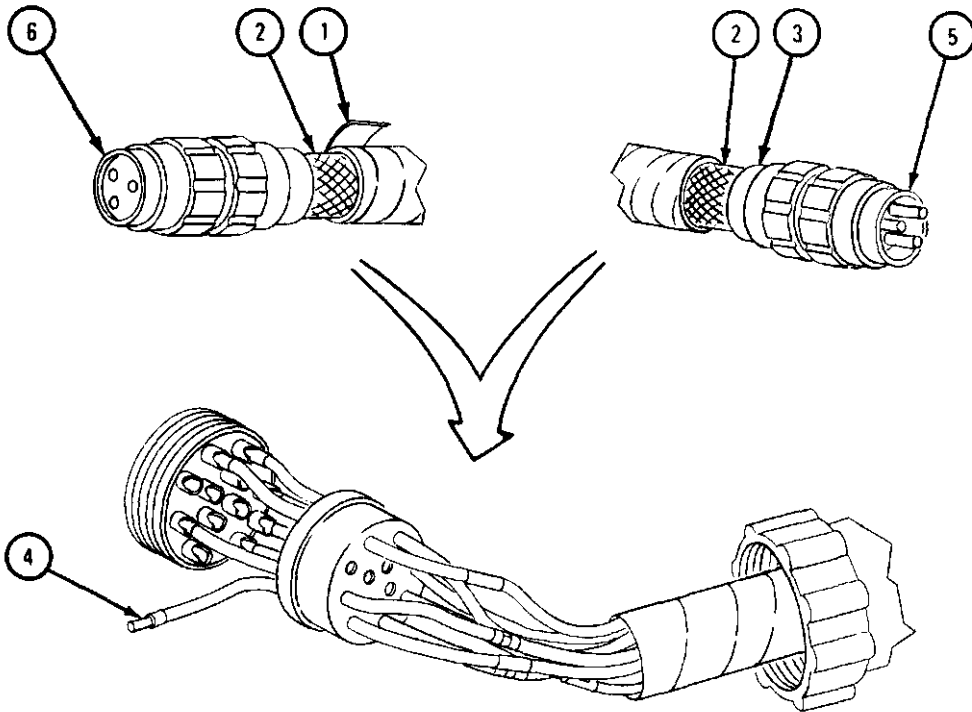

TA 085573.

d. Replacement.**FRAME 1**

1. Lay out generator-to-regulator harness (1) in engine compartment as noted.
2. Using spanner wrench, screw on and tighten generator-to-regulator harness connector (2) to regulator (3).
3. Using spanner wrench, screw on and tighten generator-to-regulator harness connector (4) to generator (5).

CAUTION

Generator must be polarized before starting engine or generator will be damaged.

NOTE

Follow-on Maintenance Action Required:

1. Reconnect battery ground cable. Refer to para 7-58.
2. Polarize generator. Refer to para 7-3.

END OF TASK

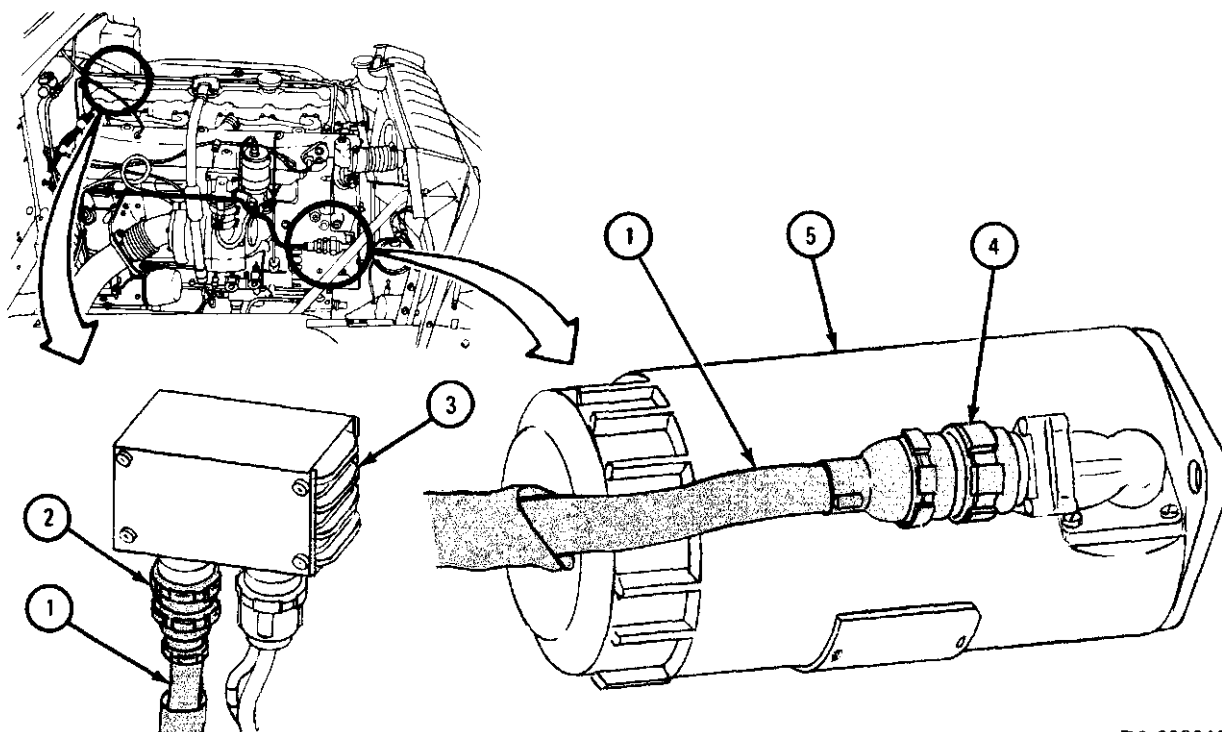

TA 083346

7-60. TRAILER CONNECTOR ELECTRICAL CABLE REMOVAL AND REPLACEMENT.

TOOLS: None

SUPPLIES: None

PERSONNEL: One

EQUIPMENT CONDITION: Truck parked, engine off, handbrake set.

a. Removal.

FRAME 1

1. Pull off connector (1) from receptacle (2) on truck.
2. Pull off connector (3) from receptacle (4) on trailer.
3. Take off electrical cable (5).

END OF TASK

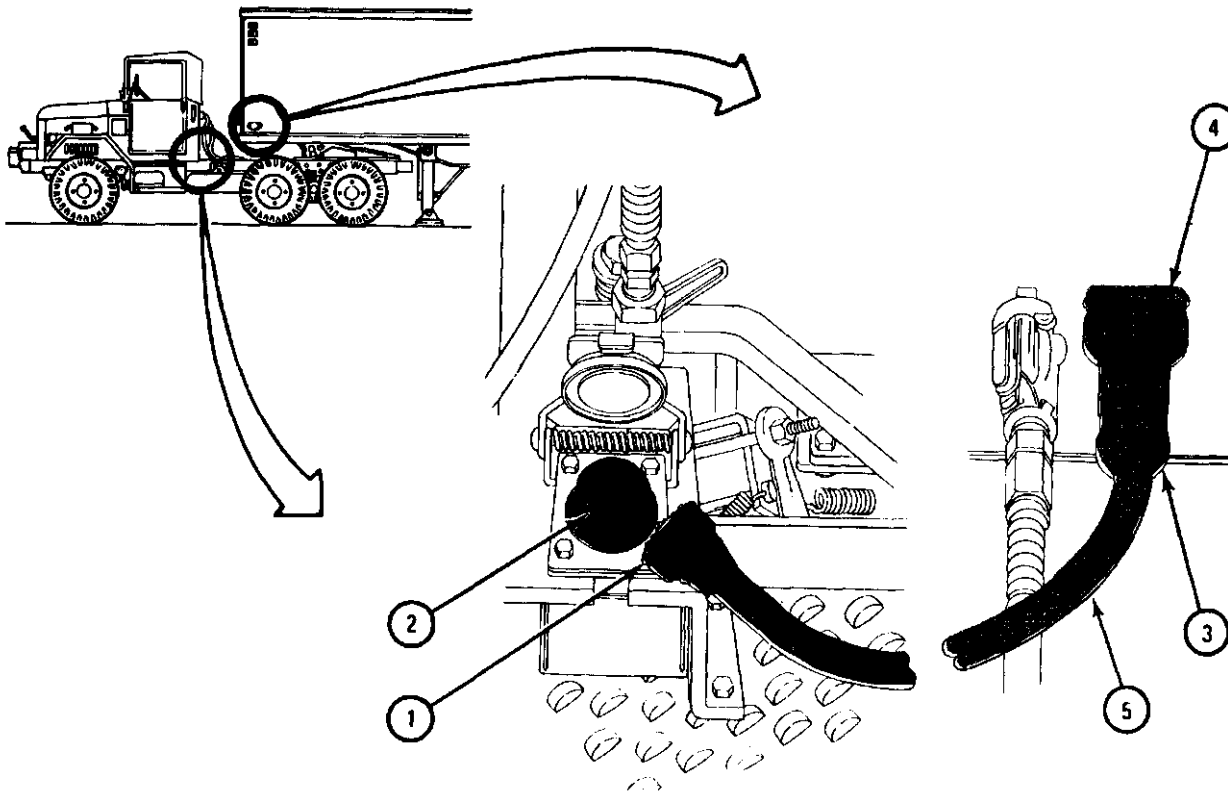

TA 083393

b. Replacement.

FRAME 1

1. Put electrical cable (1) in place between truck and trailer.
2. Push connector (2) into receptacle (3) on trailer.
3. Push connector (4) into receptacle (5) on tractor.

END OF TASK

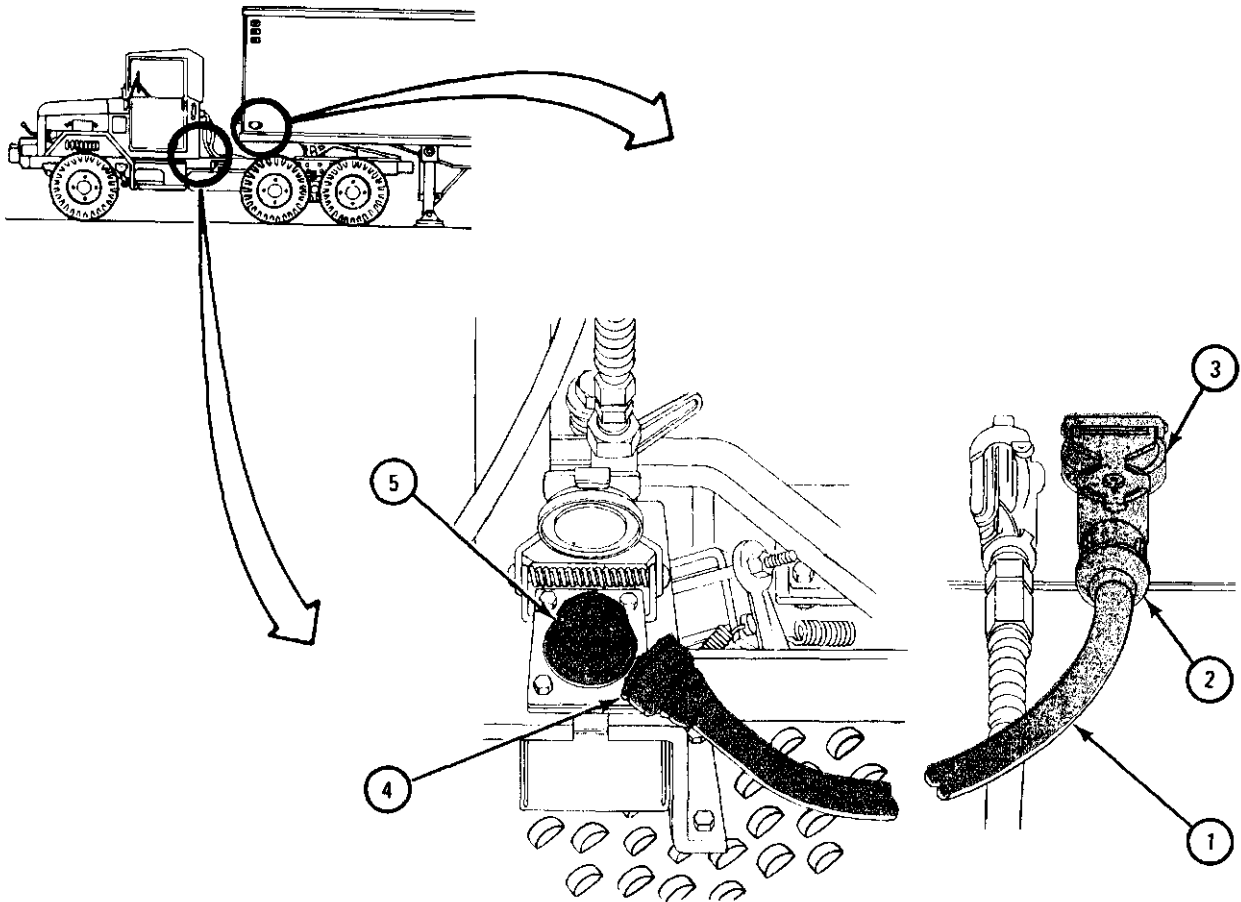

TA 083394

7-61. TRAILER ELECTRICAL COUPLING RECEPTACLE REMOVAL AND REPLACEMENT.

NOTE

Trailer electrical coupling receptacle may or may not be mounted on a bracket. This task is the same for all trailer electrical coupling receptacles.

TOOLS: 7/16-inch wrench (2)
Soldering iron

SUPPLIES: Solder

PERSONNEL: One

EQUIPMENT CONDITION: Truck parked, engine off, handbrake set.

a. Removal.

FRAME 1

1. Lift receptacle cover (1). Using 7/16-inch wrenches, unscrew and take off four nuts (2), four lockwashers (3), ground wire (4), four capscrews (5), and cover.
2. Pull coupling receptacle (6) with wiring harness (7) forward.

GO TO FRAME 2

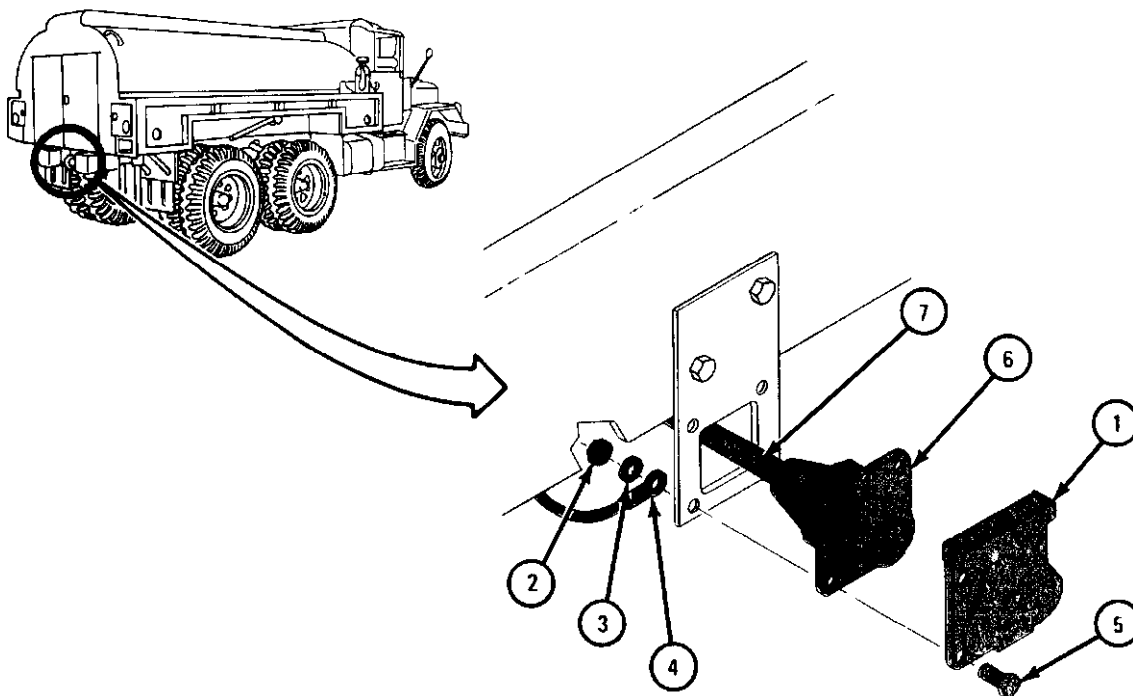

TA 083263

FRAME 2

1. Unscrew and slide nut (1) back on wires (2).
2. Pull grommet (3) back on wires (2) until contact pins (4) can be seen.

NOTE

Contact pins (4) and wires (2) are lettered and tagged. Note position of wires on contact pins so that they will be put back in the right places.

3. Using soldering gun, unsolder and take wires (2) off contact pins (4).

END OF TASK

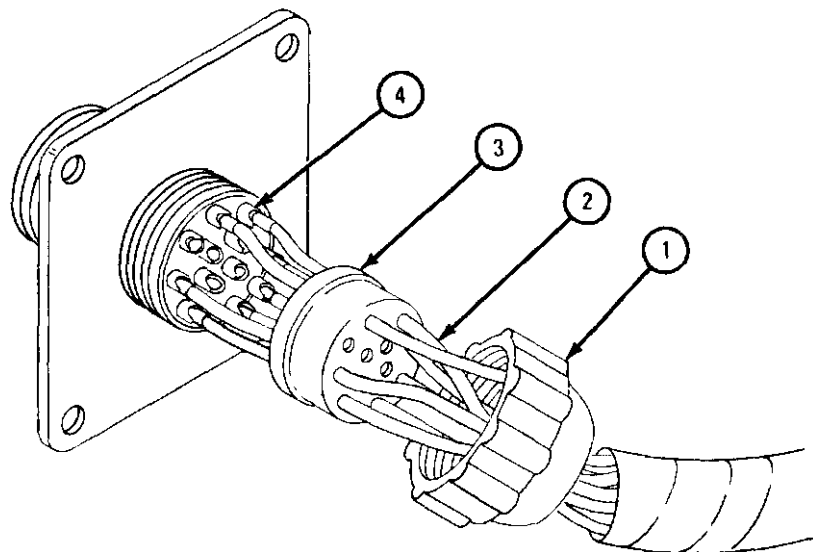

TA 101638

b. Replacement.

FRAME 1

1. Using soldering iron, solder wires (1) onto contact pins (2) as noted.
2. Slide grommet (3) forward on wires (1) until it is flush with receptacle (4).
3. Screw on and tighten nut (5).

GO TO FRAME 2

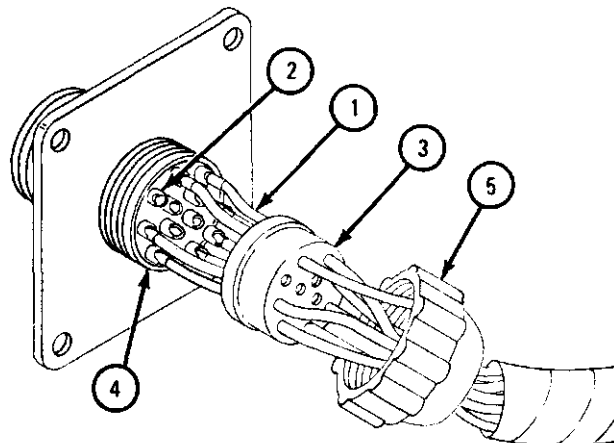
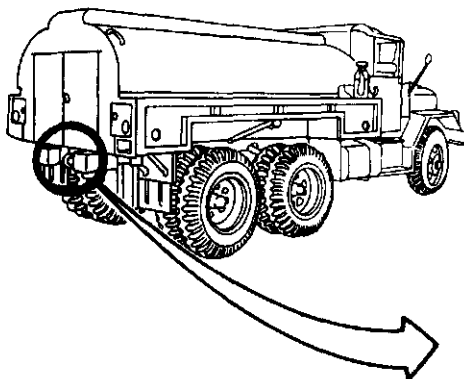

TA 101639

FRAME 2

1. Hold receptacle (1) and cover (2) in place and align holes. Lift cover and put four capscrews (3) through holes. Put ground wire (4) on capscrew as shown.
2. Using 7/16-inch wrenches, screw on and tighten four lockwashers (5) and tighten nuts (6).

END OF TASK

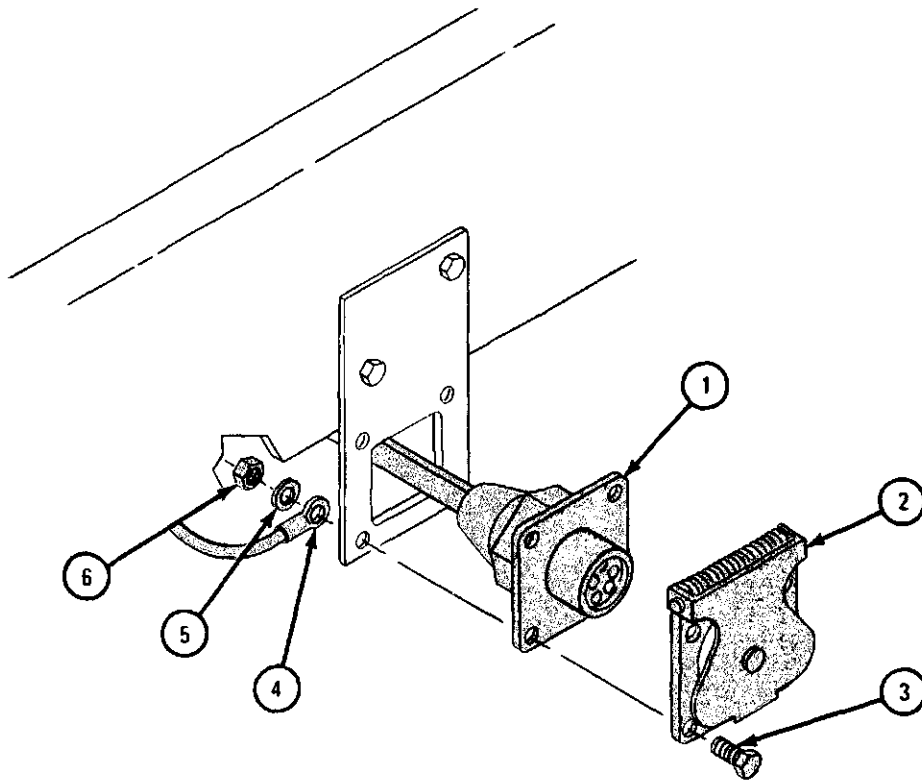

TA 083264

7-62. TRAILER ELECTRICAL RECEPTACLE REMOVAL AND REPLACEMENT
(TRUCKS M275A1 AND M275A2).

TOOLS: 7/16-inch wrench (2)
Soldering iron

Supplies: Solder

Personnel: One

EQUIPMENT CONDITION: Truck parked, engine off, handbrake set.

a. Removal.

FRAME 1

1. Using 7/16-inch wrenches, unscrew and take off two nuts (1) and protector cover (2). Take out two screws (3).

GO TO FRAME 2

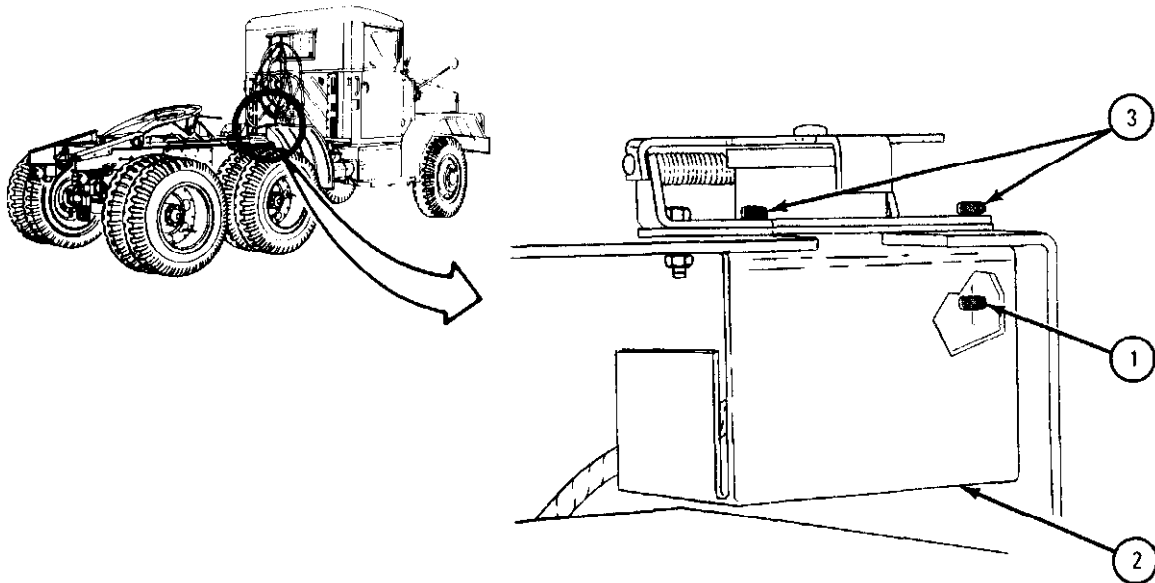

TA 083265

FRAME 2

1. Using 7/16-inch wrenches, unscrew and take off two nuts (1) and ground wire (2).
2. Take off receptacle cover (3). Open cover and take out two screws (4).
3. Lift receptacle with wires (5) up and out of bracket (6).

GO TO FRAME 3

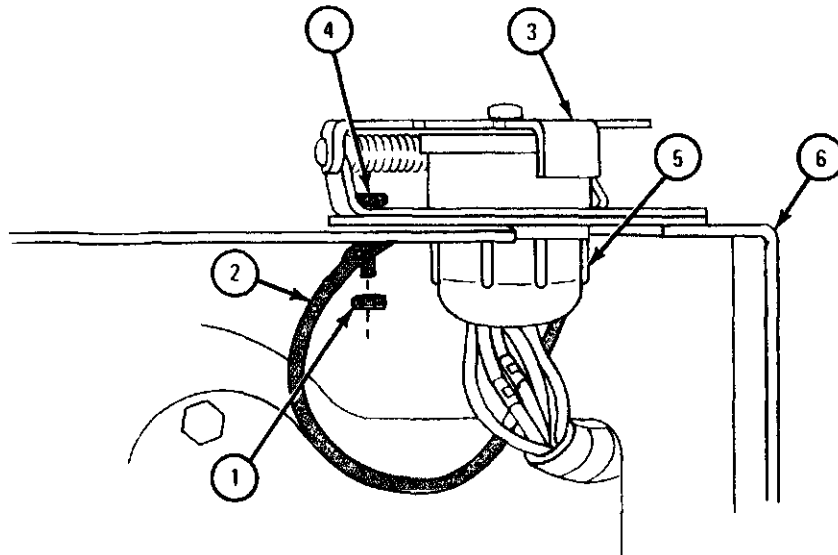

TA 085619

FRAME 3

1. Unscrew and slide nut (1) back on wires (2).
2. Pull grommet (3) back on wires (2) until contact pins (4) can be seen.

NOTE

Contact pins (4) and wires (2) are lettered and tagged.
Note position of wires on contact pins so that they are
put back in the same place.

3. Using soldering iron, unsolder and take off wires (2) from contact pins (4).

END OF TASK

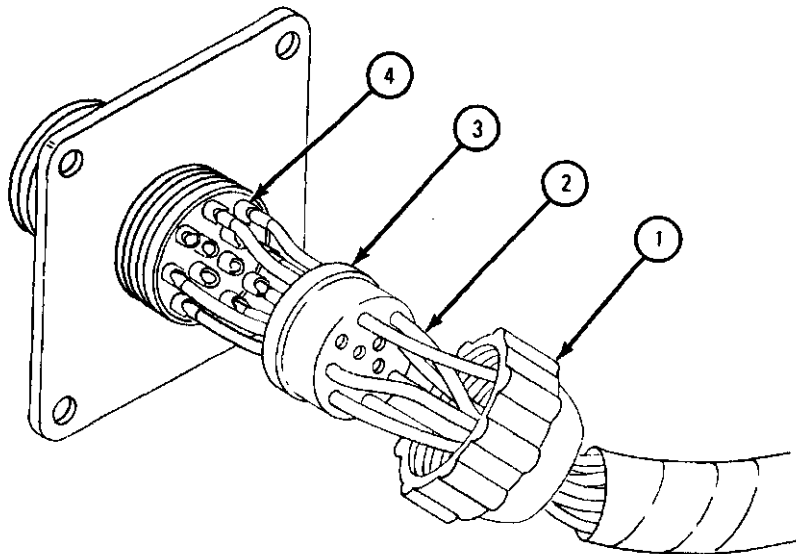

TA 085620

b. Replacement.

FRAME 1

1. Using soldering iron, solder wires (1) onto contact pins (2) as noted.
2. Slide grommet (3) forward on wires (1) until it is flush with receptacle (4).
3. Screw on and tighten nut (5).

GO TO FRAME 2

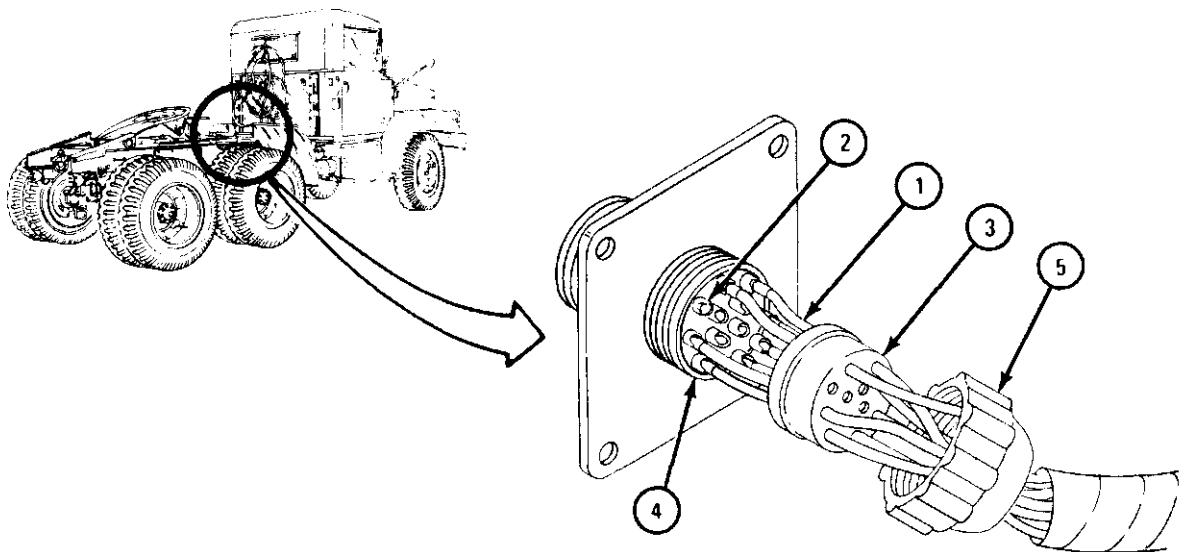

TA 085621

FRAME 2

1. Put receptacle assembly (1) in place on bracket (2) and aline holes.
2. Put receptacle cover (3) in place on receptacle (1). Lift cover and put in two screws (4).
3. Put ground wire (5) on screw (4) as shown. Using 7/16-inch wrenches, screw on and tighten two nuts (6).

GO TO FRAME 3

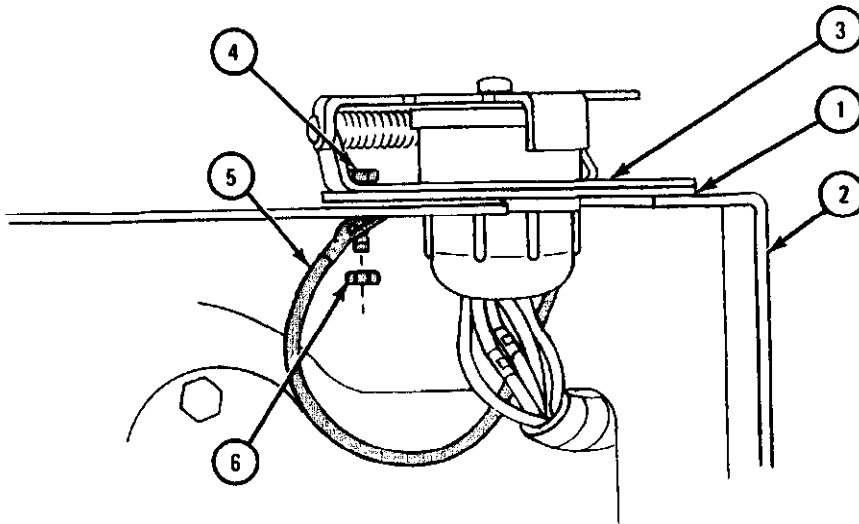

TA 085622

FRAME 3

1. Put protector cover (1) in place and align holes. Using 7/16-inch wrenches, screw in and tighten two screws (2) and two nuts (3).

END OF TASK

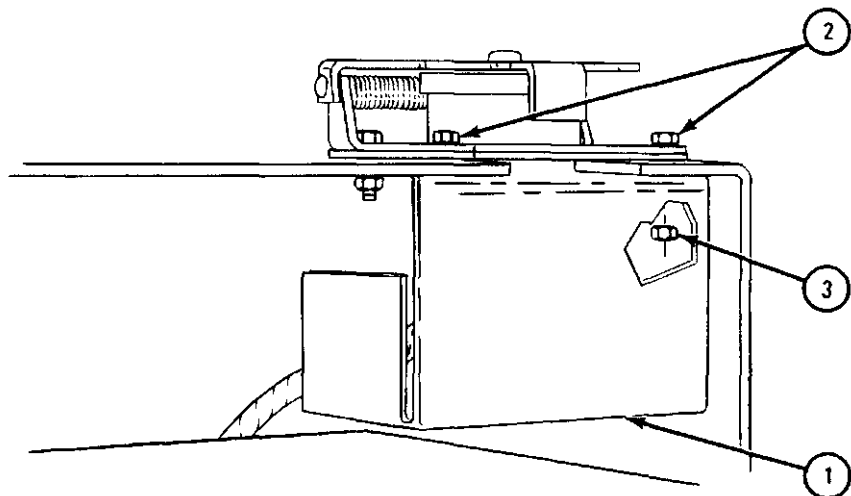

TA 085623

Section X. MISCELLANEOUS ITEMS

7-63. DIRECTIONAL SIGNAL AND SOLID STATE FLASHER REMOVAL, REPAIR, AND REPLACEMENT.

TOOLS: Flat-tip screwdriver Drill
3/8-inch wrench (2) Finely pointed awl
No. 6-32 NC tap (4) Round head machine screws (4)
No. 36 drill bit Self-tapping screws
No. 28 drill bit

SUPPLIES: None

PERSONNEL: Two

EQUIPMENT CONDITION: Truck parked, engine off, handbrake set.

a. Preliminary Procedures.

- (1) Disconnect battery ground cable. Refer to para 7-58.
- (2) Open hood and left side panel. Refer to TM 9-2320-209-10.

b. Removal.

- (1) Directional signal.

FRAME 1

1. Unscrew and take off connector (1).
2. Using screwdriver, unscrew screw (2) to loosen clamp (3).
3. Pull open clamp (3) and take off directional signal (4).

END OF TASK

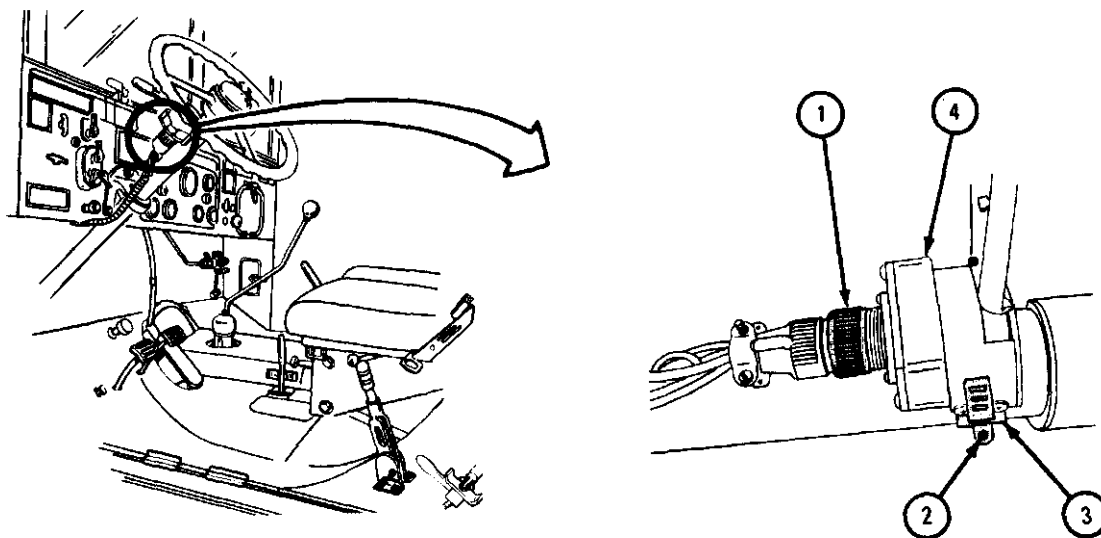

TA 083278

(2) Solid state flasher.

FRAME 1

- Soldier A 1. Unscrew and takeoff connector (1).
- Soldier B 2. Working under left fender and using screwdriver, hold screw (2).
- Soldier A 3. Using 3/8-inch wrench, unscrew and take off nut (3), wire (4), and lockwasher (5).
- Soldier B 4. Take out screw (2) . Using screwdriver, hold screw (6).
- Soldier A 5. Using 3/8-inch wrench, unscrew and take off nut (7) and lockwasher (8). Take out flasher (9).
- Soldier B 6. Take out screw (6).

END OF TASK

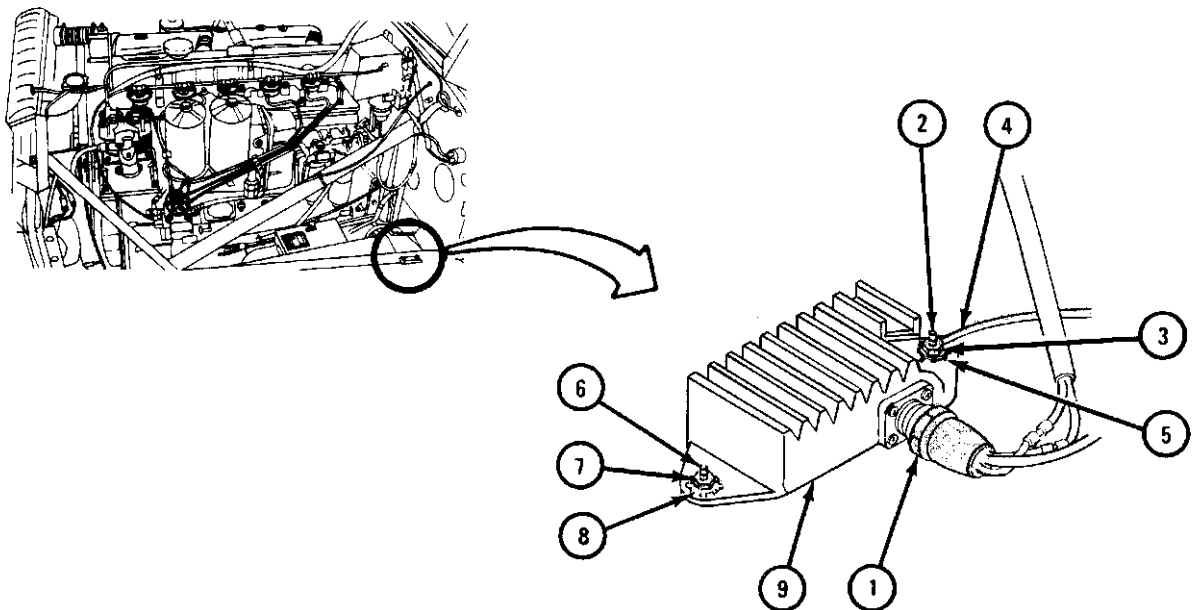

TA 083279

c. Repair.

NOTE

If directional signal assembly is new or is working go to frame 1. If assembly is not working, go to frame 2.

FRAME 1

1. Using screwdriver, unscrew and throw away two screws (1). Using drill and No. 36 drill bit and using screw holes (2) as guides, drill holes through upper body (3).

CAUTION

When using No. 28 drill bit, do not drill into upper body. Assembly may become damaged.

2. Using drill and No. 28 drill bit, drill screw holes (2).

NOTE

If tap is not available, use self-tapping screws.

3. Using tap, tap holes in upper body (3).
4. Using screwdriver, screw in and tighten two screws.
5. Do steps 1 through 4 again for other screws (4).

END OF TASK

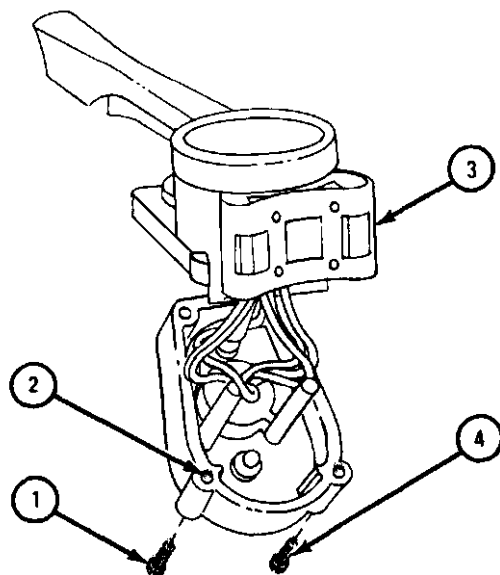

TA 104738

FRAME 2

1. Check that contact points are not pitted or burned. If points are damaged, throw assembly away.

NOTE

If plastic on four screws (1) is loose, use nail, scribe or finely pointed awl to keep it from turning.

2. Using screwdriver, unscrew and take out and throw away four screws (1).
3. Put gasket (2) in place. Put upper body (3) and lower body (4) together.
4. Using drill and No. 36 drill bit and using screw holes (5) as guides, drill holes through upper body (3).

CAUTION

When using No. 28 drill bit, do not drill into upper body (3). Assembly may be damaged.

5. Using drill and No. 28 drill bit, drill screw holes (5).

NOTE

If tap is not available, use self-tapping screws.

6. Using tap, tap holes in upper body (3).
7. Using screwdriver, screw in and tighten four screws.

END OF TASK

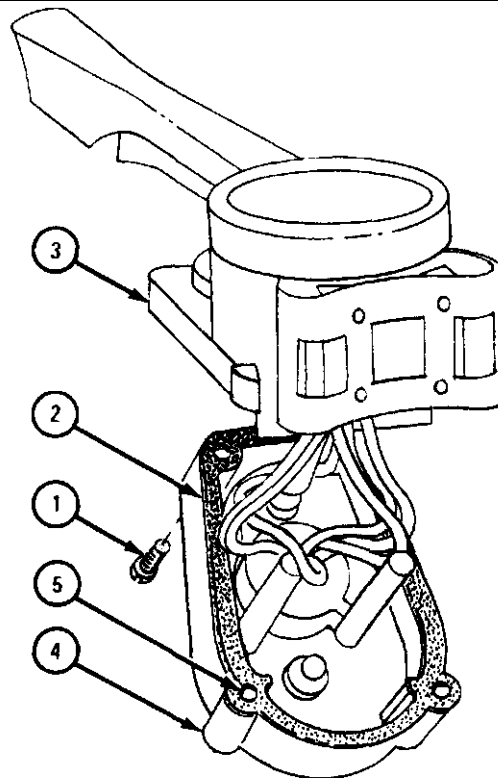

TA 104739

d. Replacement.

(1) Solid state flasher.

FRAME 1

Soldier A 1. Working under left fender, put two screws (1) through screw holes in fender. Hold screws in place.

Soldier B 2. Put flasher (2) on two screws (1). Put lockwashers (3) on screws and put wire (4) on rear screw as shown. Screw on two nuts (5) and using 3/8-inch wrench, hold nuts.

Soldier A 3. Using screwdriver, tighten two screws (1).

Soldier B 4. Screw on and tighten connector (6).

END OF TASK

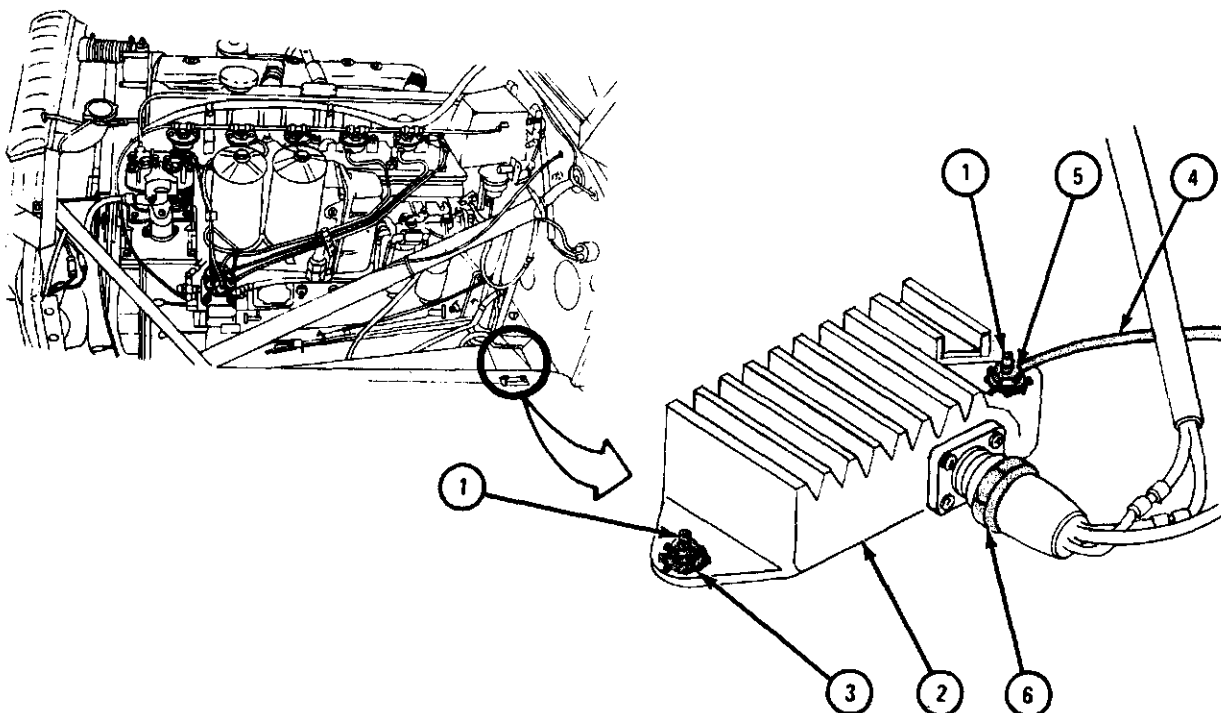

TA 083280

(2) Directional signal.

FRAME 1

1. Hold clamp (1) with directional signal (2) on steering column (3). Arm (4) must be on left side of steering column.
2. Put end of clamp (1) in slot under screw (5) and using screwdriver, tighten screw.
3. Screw on and tighten connector (6).

NOTE

Follow-on Maintenance Action Required:

1. Reconnect battery ground cable. Refer to para 7-58.
2. Close hood and left side panel. Refer to TM 9-2320-209-10.

END OF TASK

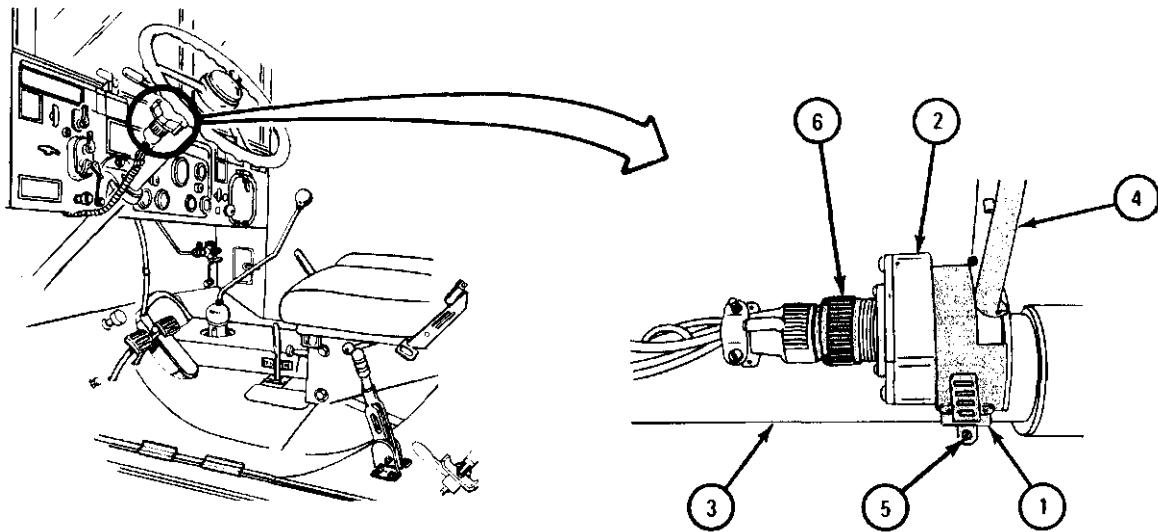

TA 083281

7-64. MANIFOLD HEATER SWITCH REMOVAL AND REPLACEMENT.

TOOLS: Cross-tip screwdriver (Phillips type)

SUPPLIES: Tags

PERSONNEL: One

EQUIPMENT CONDITION: Truck parked, engine off, handbrake set.

- a. Preliminary Procedure. Disconnect battery ground cable. Refer to para 7-58.
- b. Removal.

FRAME 1

- 1. Hold switch (1) from behind panel (2) and using screwdriver, unscrew two screws (3).

NOTE

Tag electrical connectors (4) so they will be put back in right place.

- 2. Hold switch (1) below panel (2) and take off two connectors (4).

END OF TASK

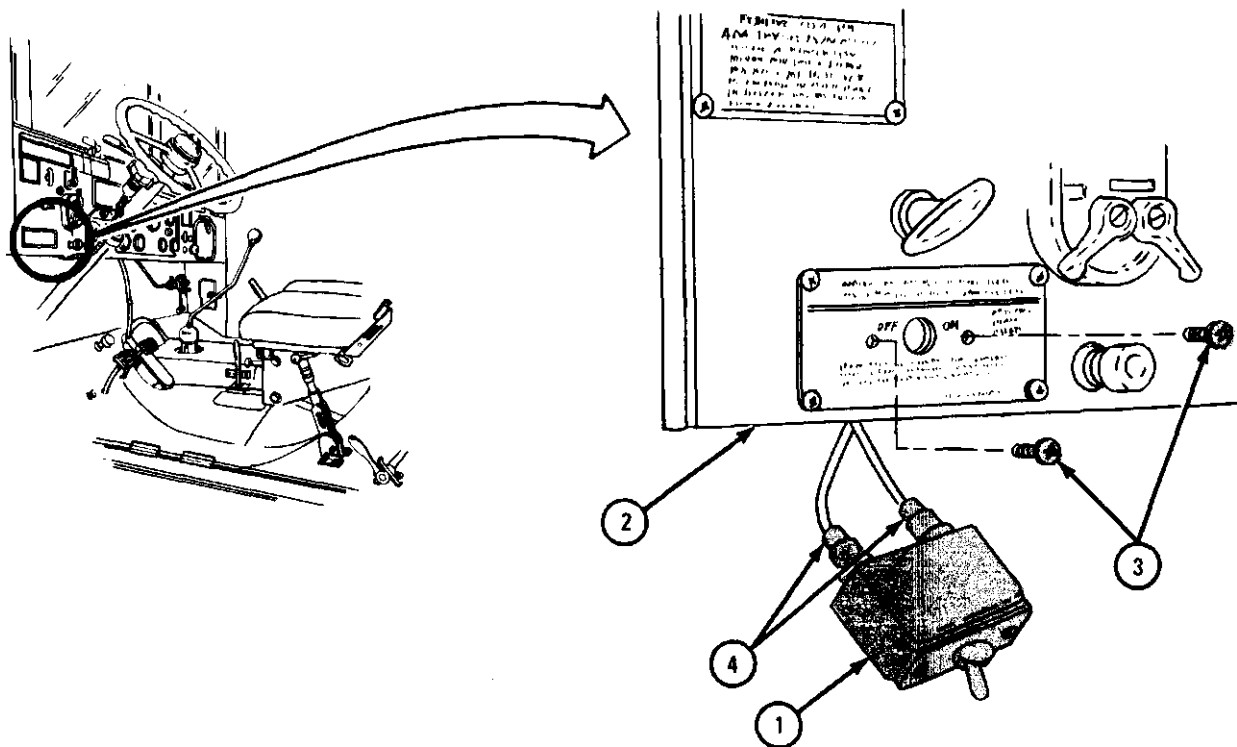

TA 047281

c. Replacement.

FRAME 1

1. Hold switch (1) below panel (2) and plug two connectors (3) into switch as tagged. Take off tags.
2. Look at ON-OFF position markings on switch (1). Set switch to OFF position.
3. Put switch lever (4) through hole from behind panel and align screw holes.
4. Hold switch (1) in place and screw in two screws (5). Using screwdriver, tighten screws.

NOTE

Follow-on Maintenance Action Required:

1. Reconnect battery ground cable. Refer to para 7-58.
2. Operate manifold heater to check switch. Refer to TM 9-2320-209-10.

END OF TASK

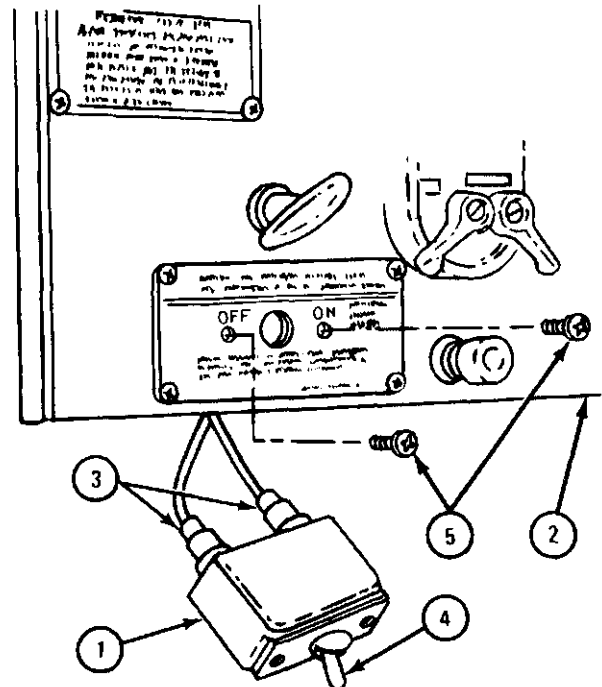
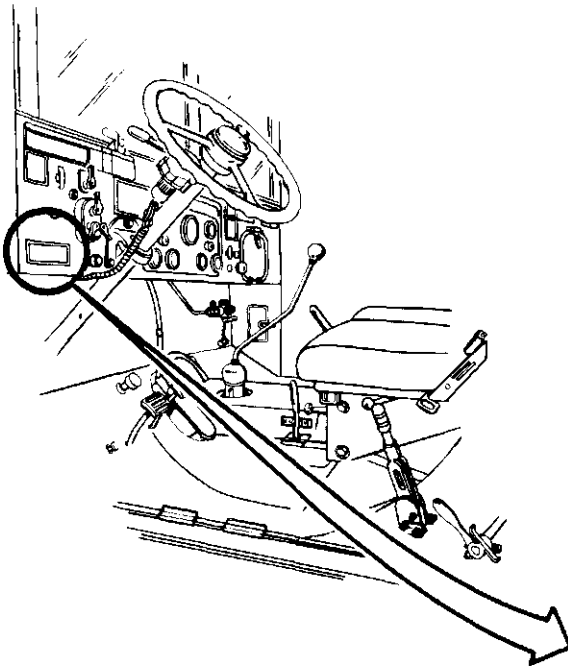

TA 047282

7-65. HEADLIGHT DIMMER SWITCH REMOVAL AND REPLACEMENT.

TOOLS: Cross-tip screwdriver (Phillips type)

SUPPLIES: None

PERSONNEL: Two

EQUIPMENT CONDITION: Truck parked, engine off, handbrake set.

a. Preliminary Procedures.

(1) Open hood and left side panel. Refer to TM 9-2320-209-10.

(2) Remove battery ground cable. Refer to para 7-58.

CAUTION

Make sure that main light switch is set to OFF position or electrical damage may result.

b. Removal.

FRAME 1

1. Using screwdriver, unscrew and take out two screws (1) and starwashers (2).
2. Push dimmer switch plunger (3) through hole in floor.

GO TO FRAME 2

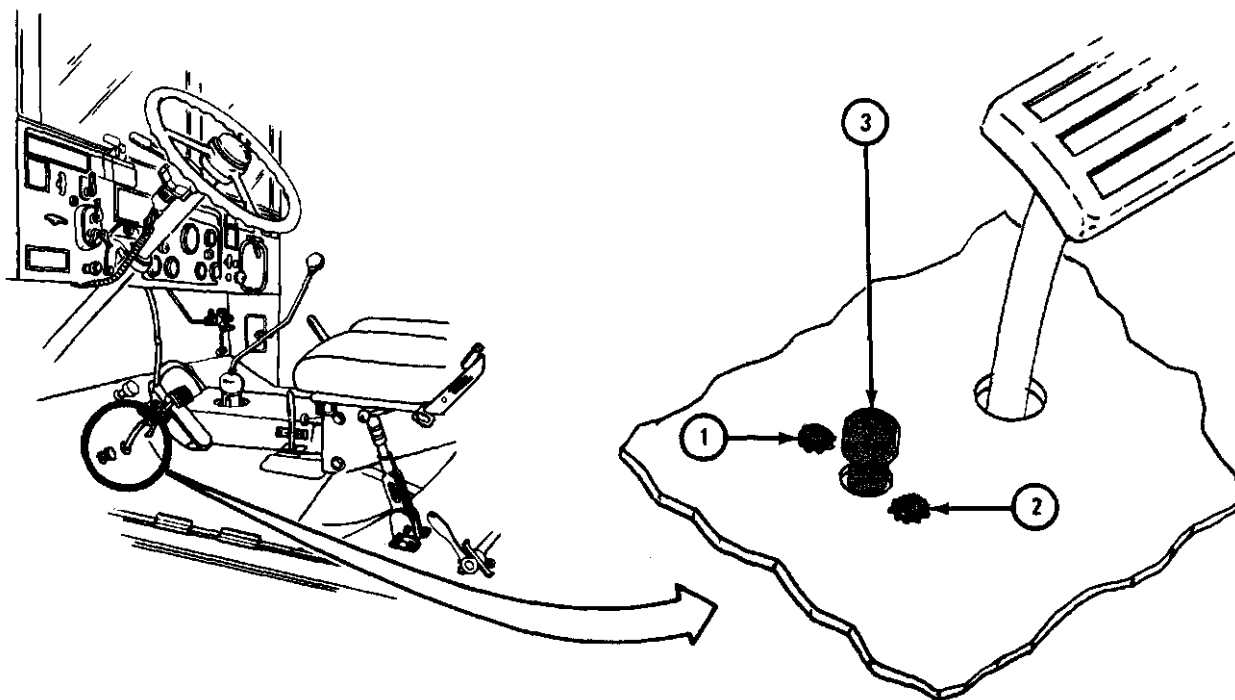

TA 047277

FRAME 2

1. Lift dimmer switch (1) with protective cover (2) away from cab floor (3) as shown.
2. Lift dimmer switch (1) away from protective cover (2).

NOTE

Tag wires to dimmer switch (1) before taking them off so that they will be put back in same receptacles.

3. Unplug three connectors (4) from dimmer switch (1) and take out dimmer switch.

END OF TASK

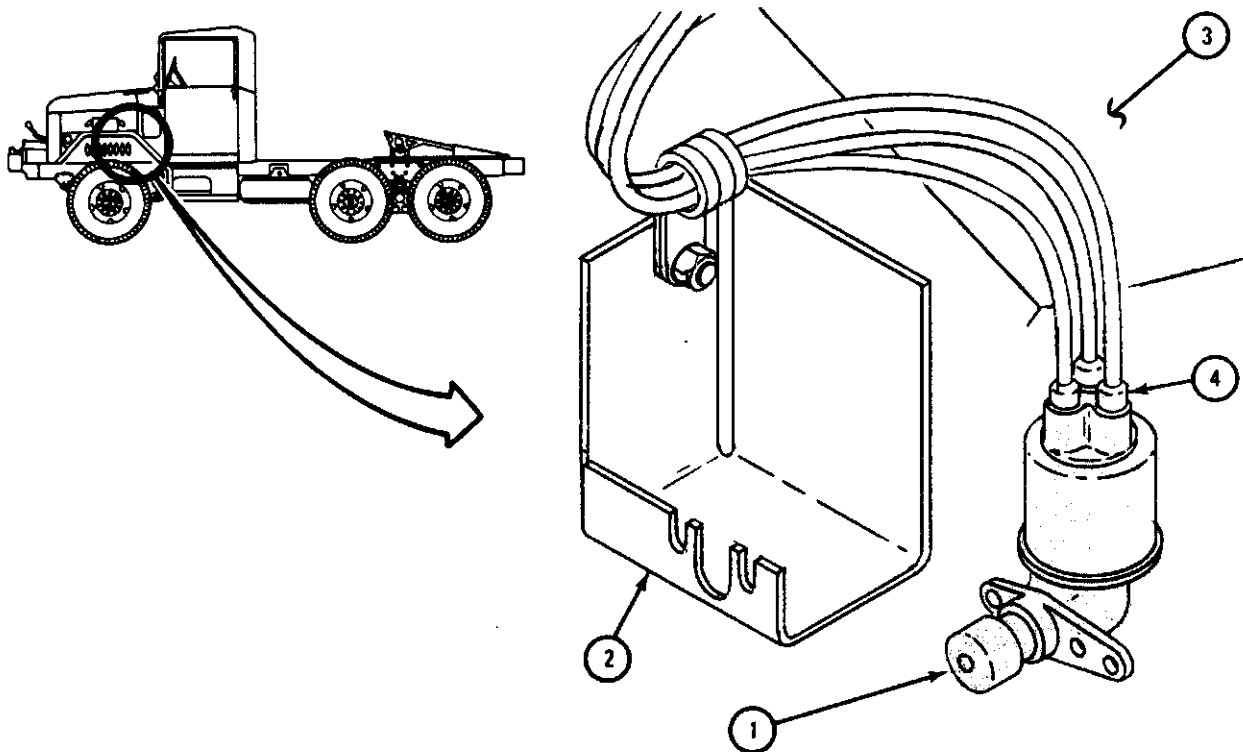

TA 047278

c. Replacement.

FRAME 1

NOTE

Check tags on connectors (1) so each will be put back in right place.

1. Plug three connectors (1) into dimmer switch receptacles (2).

GO TO FRAME 2

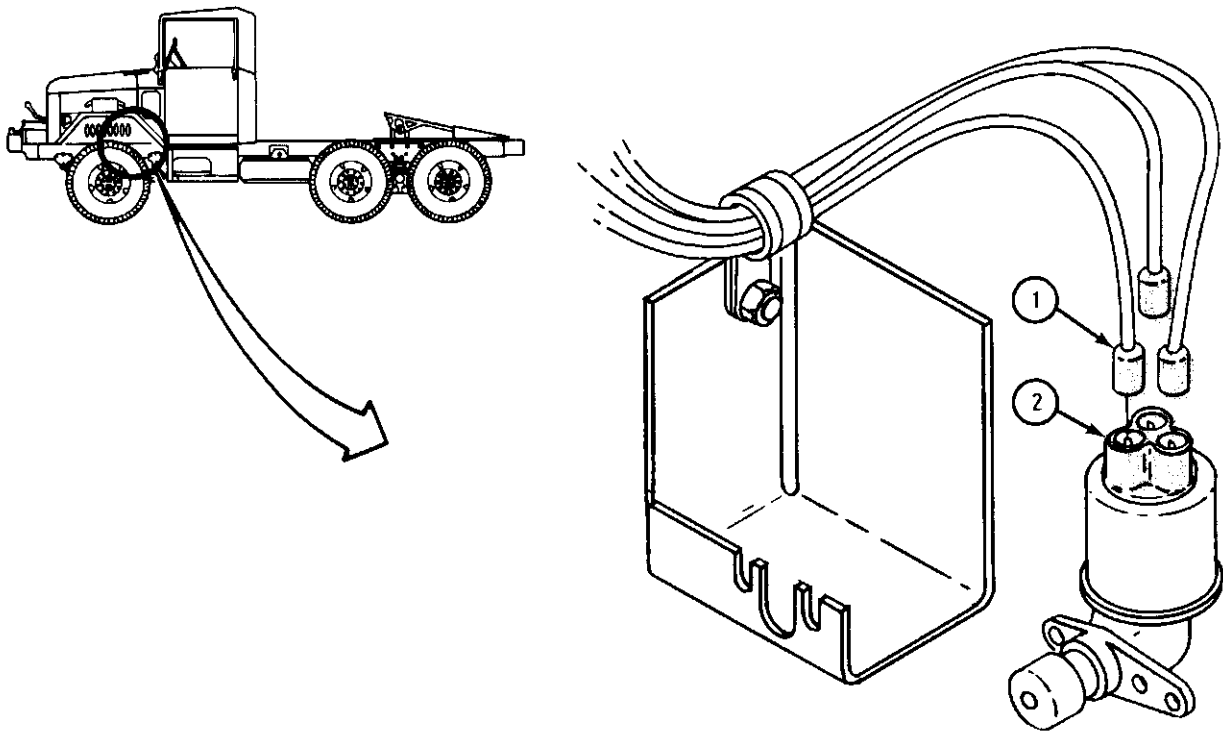

TA 047279

FRAME 2

- Soldier A 1. Put dimmer switch plunger (1) through hole in floor (2) and position dimmer switch (3) as shown. Aline two holes in mounting flange (4) with holes in floor.
- Soldier B 2. Tell soldier A when mounting holes are alined. Screw in two screws (5) with starwashers (6) but do not tighten screws.
- Soldier A 3. Put protective cover (7) over dimmer switch (3). Slide slotted side (8) between flange (4) and floor (2) so slots are around screws (5). Tell soldier B when cover is in position.
- Soldier B 4. Using screwdriver, tighten two screws (5).

NOTE

Follow-on Maintenance Action Required:

1. Close hood and left side panel. Refer to TM 9-2320-209-10.
2. Replace battery ground cable. Refer to para 7-58.
3. Check operation of headlight dimmer switch. Refer to TM 9-2320-209-10.

END OF TASK

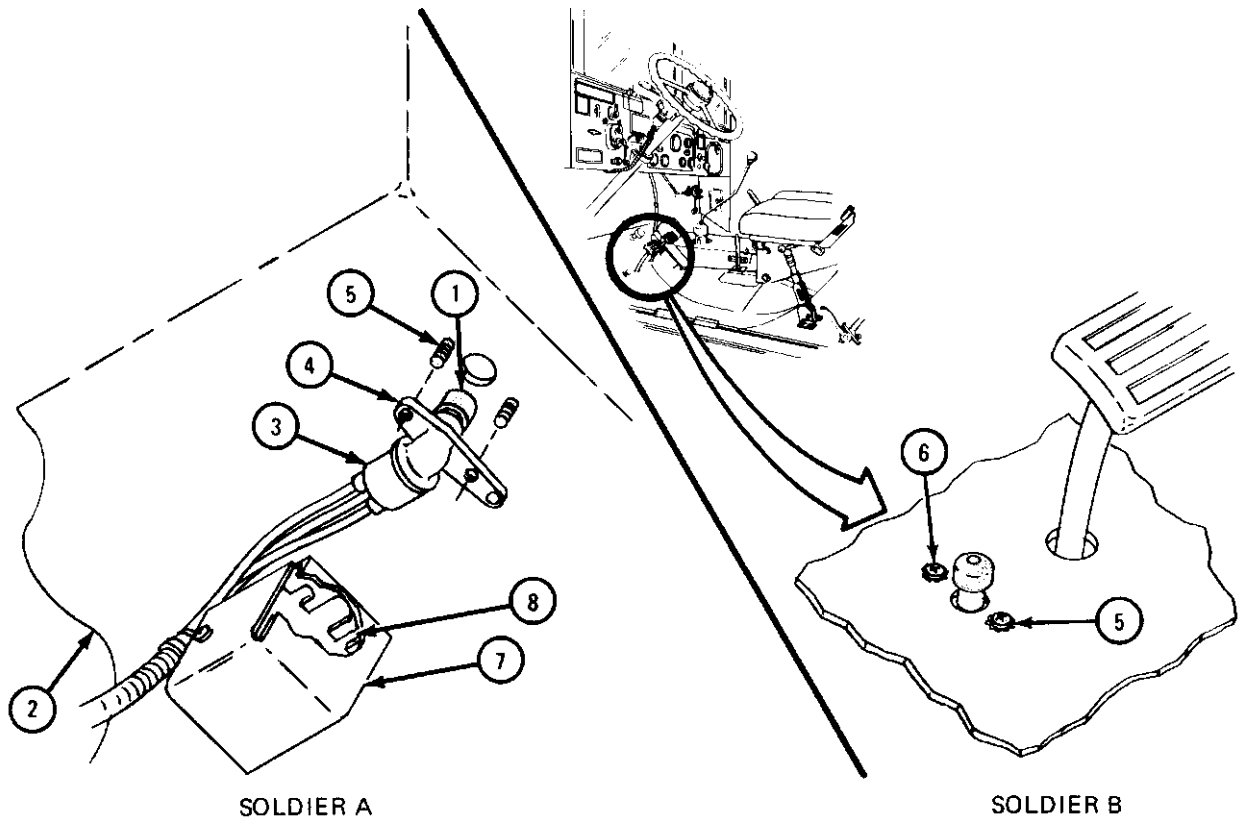

TA 047280

7-66. FLOODLIGHT HOUSING SWITCH REMOVAL, REPAIR, AND REPLACEMENT (TRUCKS M756A2 AND M764).

TOOLS: Flat-tip screwdriver

SUPPLIES: Solvent, dry cleaning, type II (SD-2), Fed. Spec P-D-680

PERSONNEL: One

EQUIPMENT CONDITION: Truck parked, engine off, handbrake set, light switch in OFF position.

- a. Preliminary Procedure. Remove floodlight sealed beam. Refer to para 7-39.
- b. Removal.

FRAME 1

1. Unplug electrical lead (1) from connector (2).
2. Using screwdriver, unscrew and take out two screws (3). Take out retainer (4) and switch (5).
3. Using screwdriver, unscrew and take out two screws (6) and washers (7). Take out switch bracket (8).

END OF TASK

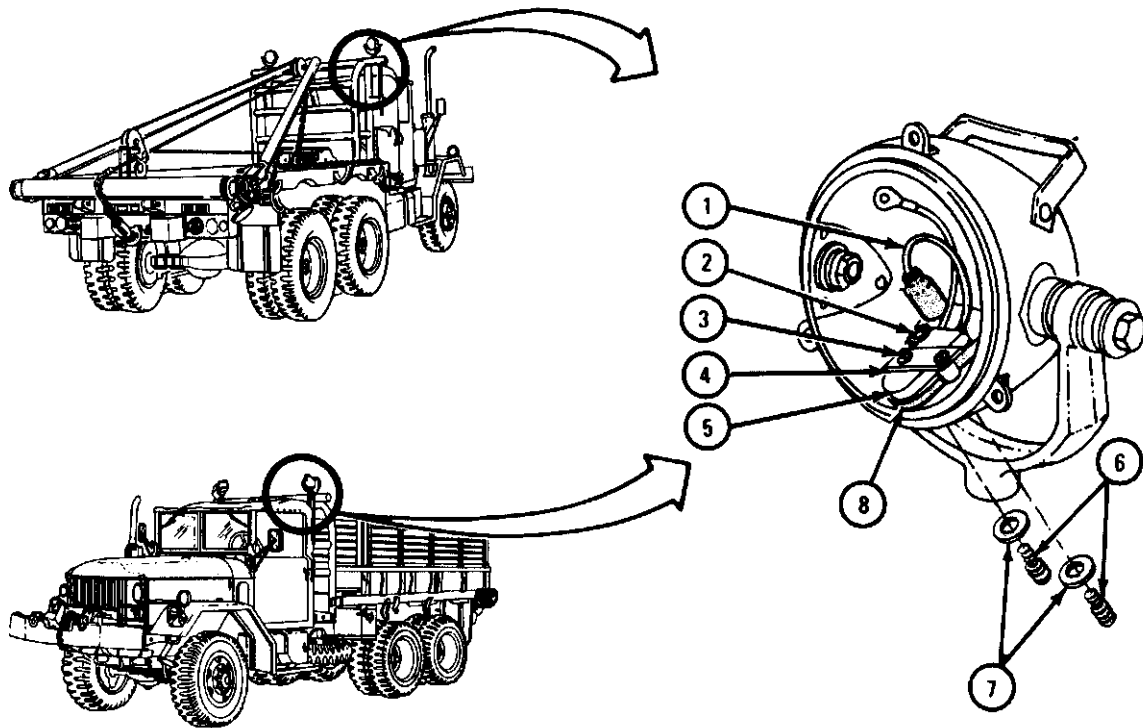

TA 046686

c. Cleaning, Inspection, and Repair.WARNING

Dry cleaning solvent is flammable. Do not use near an open flame. Keep a fire extinguisher nearby when solvent is used. Use only in well-ventilated places. Failure to do this may result in injury to personnel and damage to equipment.

- (1) Using solvent, clean screws, retainer, and switch bracket.
- (2) Check wires for breaks and frayed insulation. Check switch for damage.
- (3) Check screws and switch bracket for damaged threads.
- (4) Throw away all damaged parts and get new ones in their place.

d. Replacement.

FRAME 1

1. Put switch bracket (1) in light housing (2) and align holes.
2. Using screwdriver, screw in and tighten two screws (3) and washers (4).
3. Put switch (5) on switch bracket (1). Put switch retainer (6) over switch and align holes.
4. Using screwdriver, screw in and tighten two screws (7).
5. Plug electrical lead (8) into connector (9).

NOTE

Follow-on Maintenance Action Required:
Replace floodlight sealed beam. Refer to para 7-39.

END OF TASK

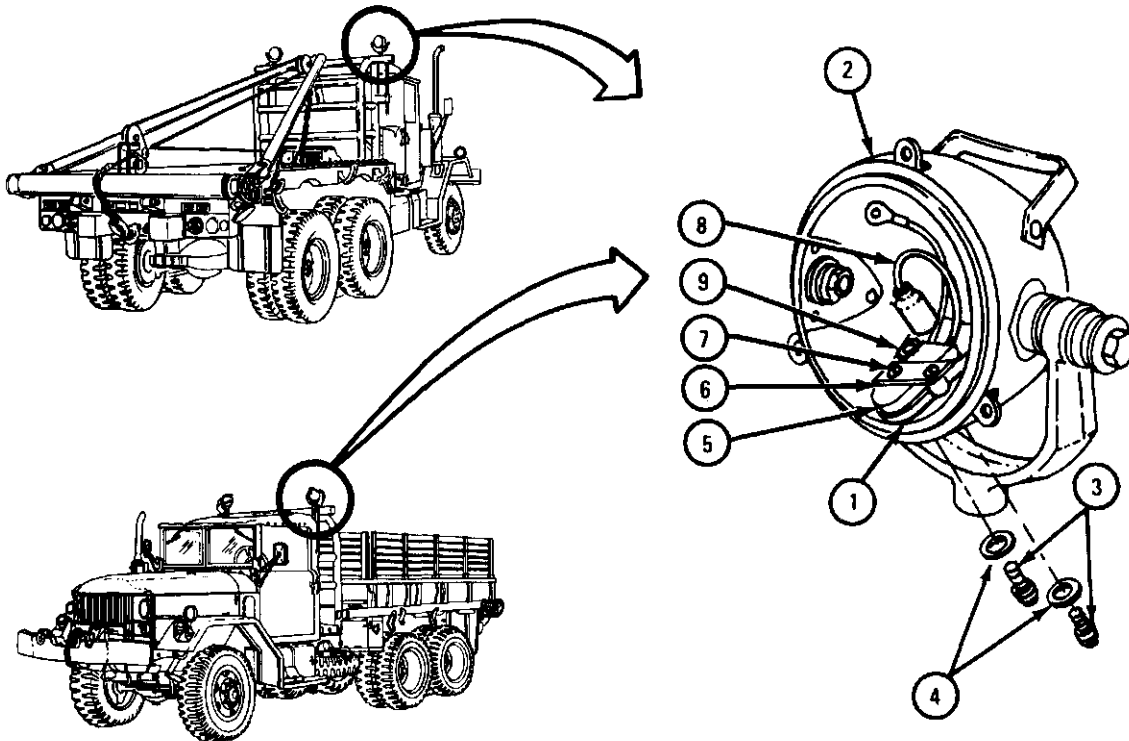

TA 046687

7-67. HYDRAULIC STOPLIGHT SWITCH REMOVAL AND REPLACEMENT (ALL TRUCKS EXCEPT MODELS M275A1 and M275A2).

TOOLS: 1-inch open end wrench
 Diagonal pliers
 Wire strippers
 Hand crimping tool

SUPPLIES: Waterproof electrical repair kit, pn H020-5701060 (used only when replacing type 7760414 switch with type 7064588)
 Drip pan

PERSONNEL: One

EQUIPMENT CONDITION: Truck parked, engine off, handbrake set.

CAUTION

Make sure that MAIN light switch is set to OFF position.

a. Removal.

NOTE

Place drip pan under truck to catch hydraulic fluid.

FRAME 1

1. From under truck, check type of stoplight switch (1 or 2) as shown below.
 GO TO FRAME 2 FOR STOPLIGHT SWITCH (1), PN 7064588.
 GO TO FRAME 3 FOR STOPLIGHT SWITCH (2), PN 7760414

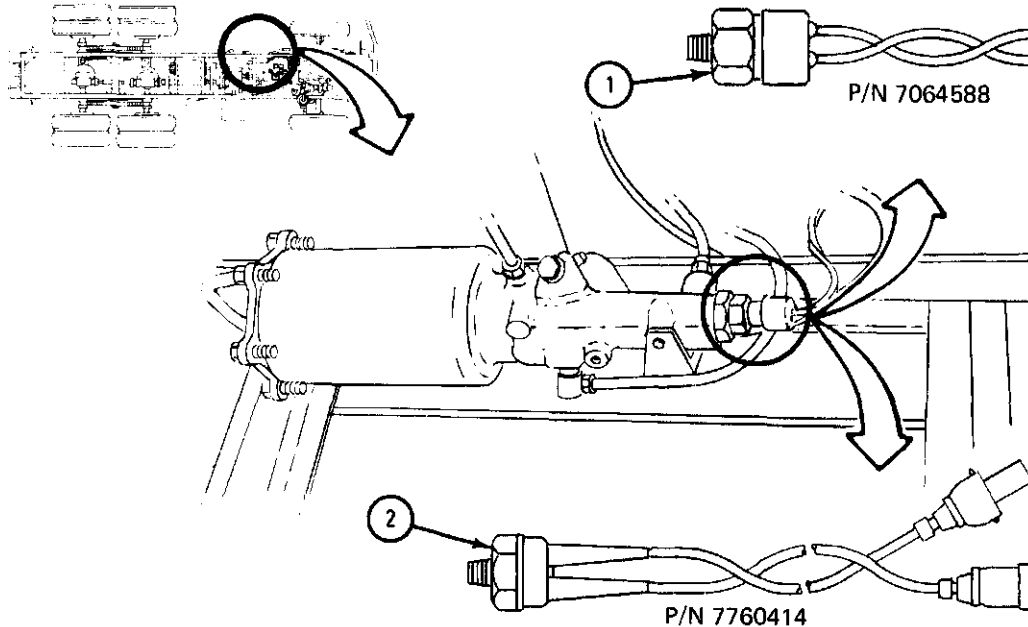

TA 047269

FRAME 2

1. Pull connector (1) off stoplight switch (2).
2. Using 1-inch open end wrench, unscrew stoplight switch (2) from air hydraulic cylinder (3).

END OF TASK

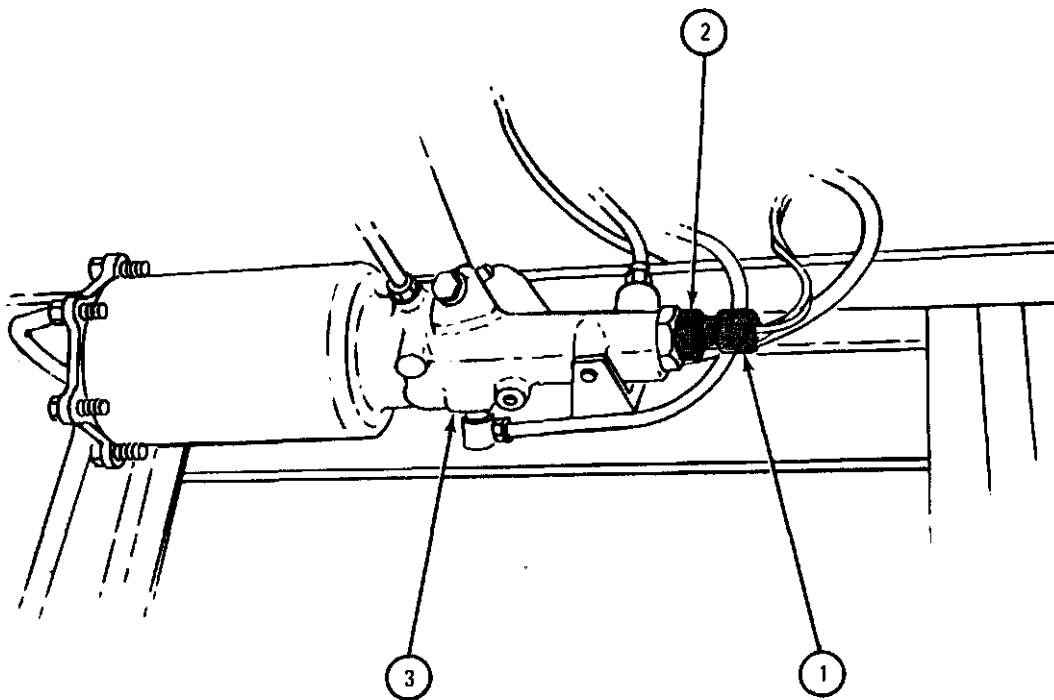

TA 047270

FRAME 3

1. Pull two connectors (1) out of chassis harness receptacles (2).
2. Using 1-inch open end wrench, unscrew stoplight switch (3) from air hydraulic cylinder (4).
3. Take off stoplight switch (3) with cable assembly (5).

NOTE

Cable assembly (5) will be used to fit chassis harness to replacement stoplight switch, pn 7064588.

END OF TASK

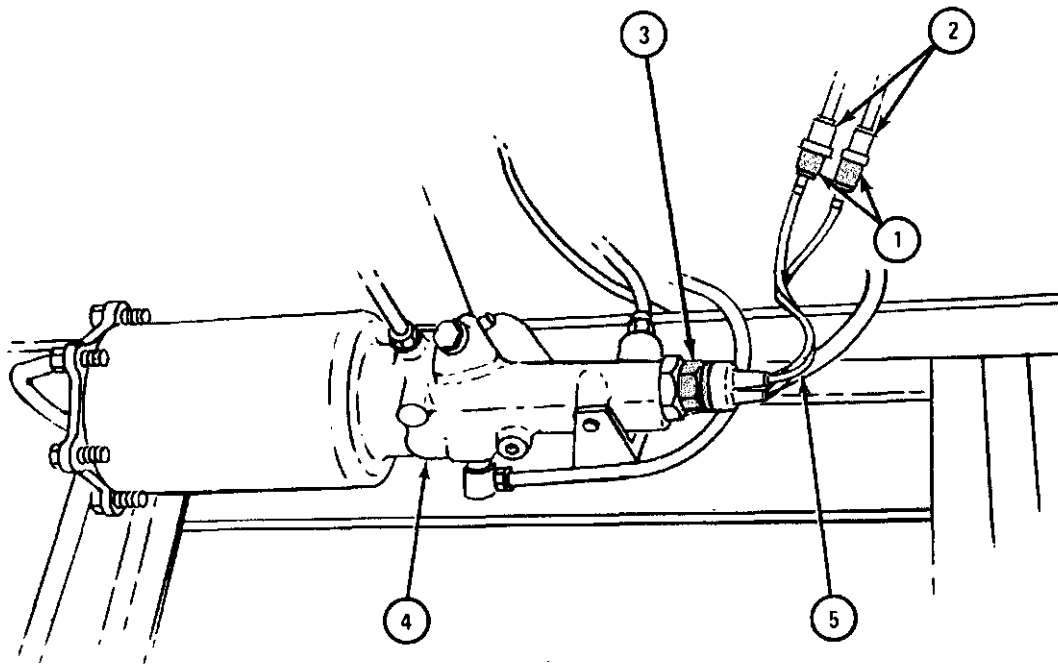

TA 047271

b. Replacement of Switch, PN 7064588.

FRAME 1

1. Screw stoplight switch (1) into air hydraulic cylinder (2) and tighten, using 1-inch open end wrench.
2. Join connector shell (3) to stoplight switch (1) by pressing in and turning right to lock.

NOTE

Follow-on Maintenance Action Required:

1. Bleed brake hydraulic system. Refer to Part 2, para 13-15 and 13-16.
2. Set MAIN light switch to STOPLIGHT and check stoplight operation by pressing brake pedal several times.

END OF TASK

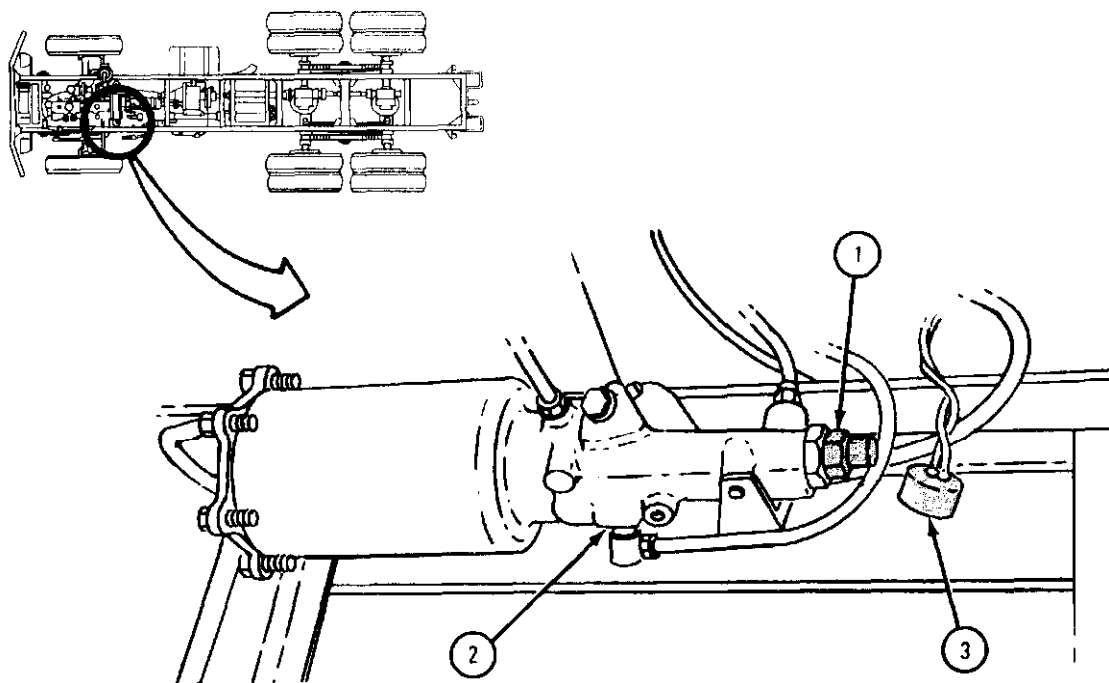

TA 047272

- c. Replacement of Switch, pn 7760414 with Switch, pn 7064588.

FRAME 1

1. Using diagonal pliers, cut wires (1) close to damaged stoplight switch (2), pn 7760414.
2. Using wire strippers, strip 5/16 inch of insulation off ends of wires (1).

NOTE

Parts (3 through 6) are in waterproof electrical repair kit, pn H020-5701060.

3. Slip two adapter grommets (3) over ends of wires (1) and slide grommets back on wire. Put wires through waterproof connector shell (4) as shown.
4. Put two male terminals (pins) (5) over stripped ends of wires (1). Using hand crimping tool, crimp pins on wires.
5. Slide adapter grommets (3) down wires (1) and put in holes at back of waterproof connector shell (4). Pull slack wire out back of shell through adapter grommets until male pins (5) seat in connector shell.
6. Push one female sleeve terminal (6) over each male pin (5).

GO TO FRAME 2

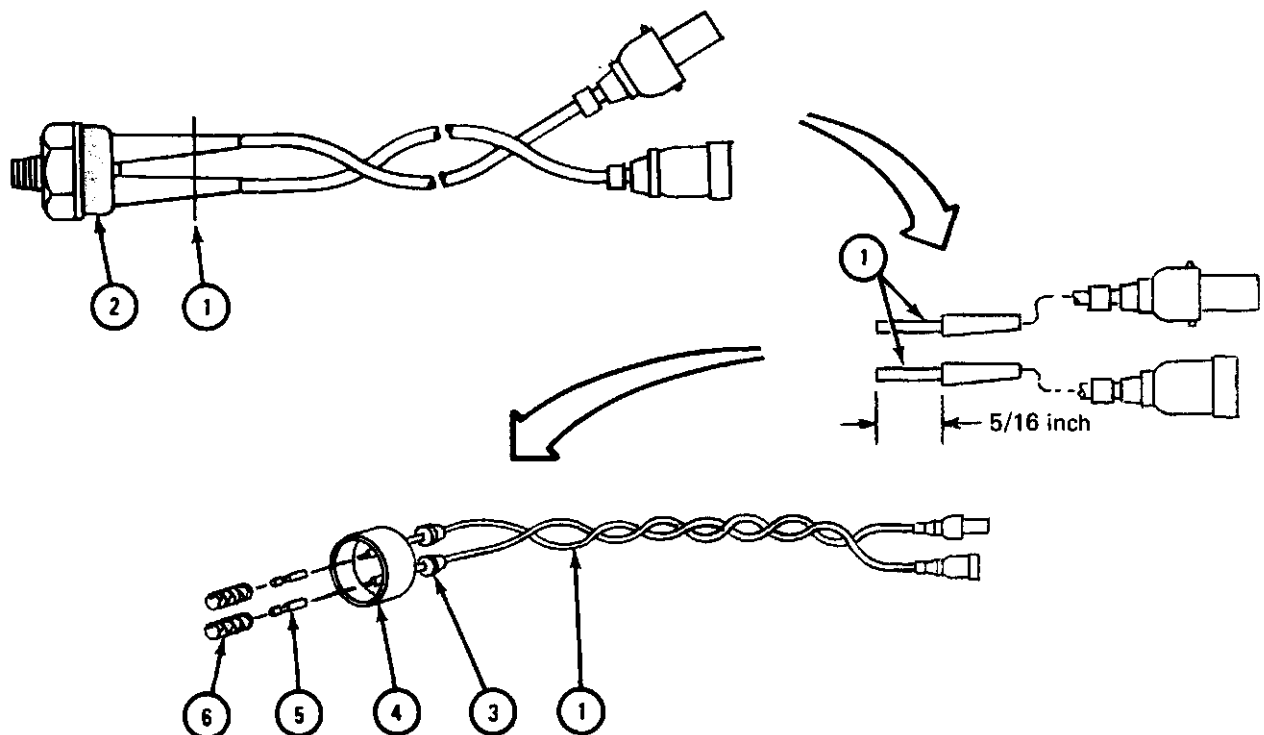

TA 047273

FRAME 2

1. Screw replacement stoplight switch (1), pn 7064588, into air hydraulic cylinder (2) and tighten, using $\frac{1}{2}$ -inch open end wrench.
2. Join connector (3) to stoplight switch (1). Press connector in and turn to right to lock.
3. Join two cable connectors (4) to truck harness connectors (5).

NOTE

Follow-on Maintenance Action Required:

1. Bleed brake hydraulic system. Refer to Part 2, para 13-15 and 13-16.
2. Set MAIN light switch to STOPLIGHT and check stoplight operation by pressing brake pedal several times.

END OF TASK

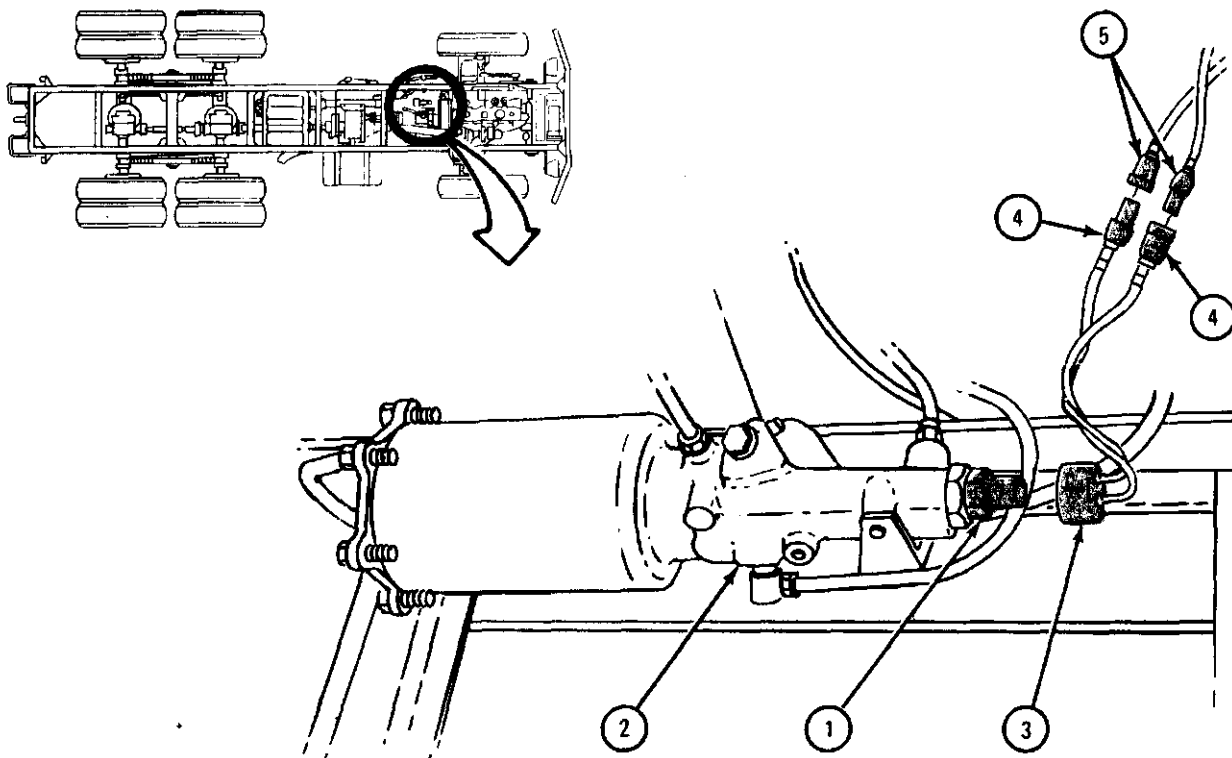

TA 047274

7-68. AIR STOPLIGHT SWITCH REMOVAL AND REPLACEMENT (TRUCKS M275A1 AND M275A2).

TOOLS: 2 1/4-inch open end wrench
Pipe wrench
Vise

SUPPLIES: None

PERSONNEL: One

EQUIPMENT CONDITION : Truck parked, engine off, handbrake set.

a. Preliminary Procedures.

- (1) Vent air system pressure. Refer to Part 2, para 13-20.
- (2) Disconnect battery ground cable. Refer to para 7-58.

CAUTION

Make sure that main light switch is set to OFF position or electrical damage may result.

b. Removal.

FRAME 1

NOTE

Tag cables (1) before taking them off so they will be put back in right place.

1. Take two cables (1) off air stoplight switch (2).
2. Using pipe wrench, unscrew and take out nipple (3) with air stoplight switch (2).
3. Put nipple (3) in vise. Using open end wrench, unscrew and take off air stoplight switch (2) from nipple.

END OF TASK

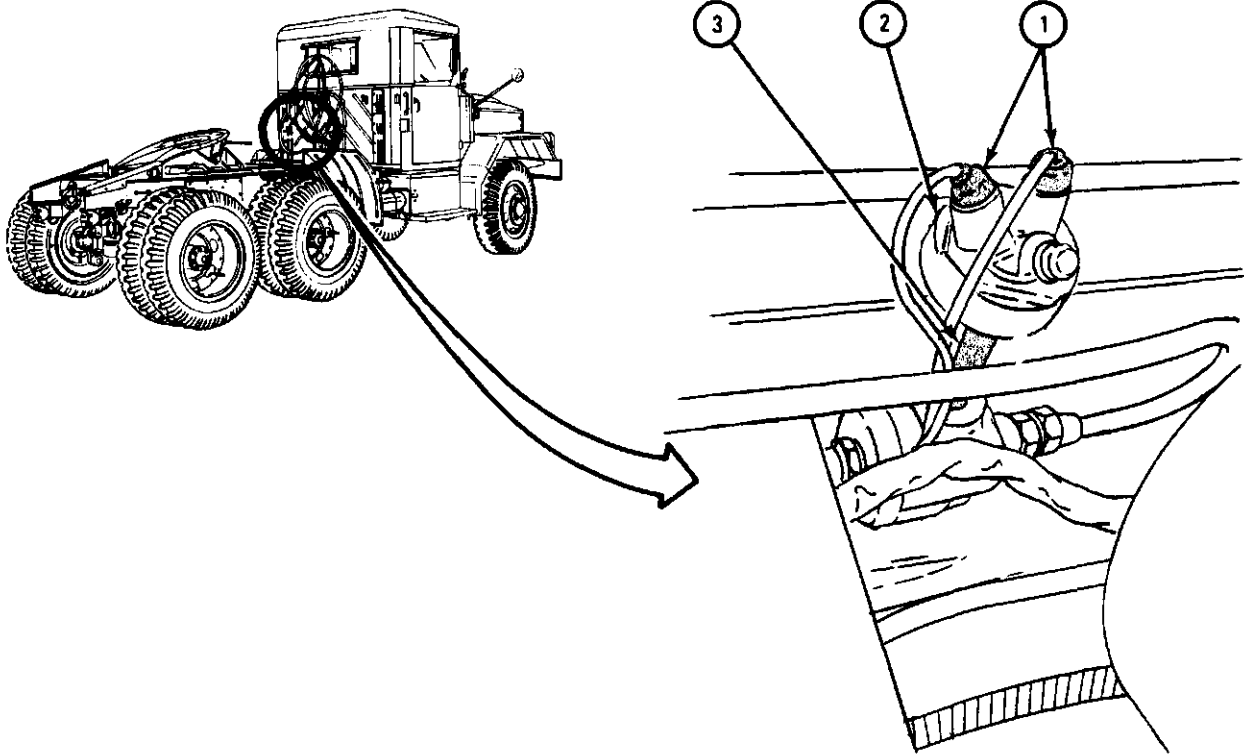

TA 047275

c. Replacement.

FRAME 1

1. Screw stoplight switch (1) on nipple (2). Hold nipple with pipe wrench while tightening stoplight switch using open end wrench.

NOTE

Check tags on cables (3) so cables will be put back in same place on switch (1).

2. Join two chassis cables (3) to stoplight switch (1) by plugging cable connectors (4) into switch as tagged. Take off tags.

NOTE

Follow-on Maintenance Action Required:

1. Reconnect battery ground cable. Refer to para 7-58.
2. Check operation of air stoplight switch. Refer to TM 9-2320-209-10.

END OF TASK

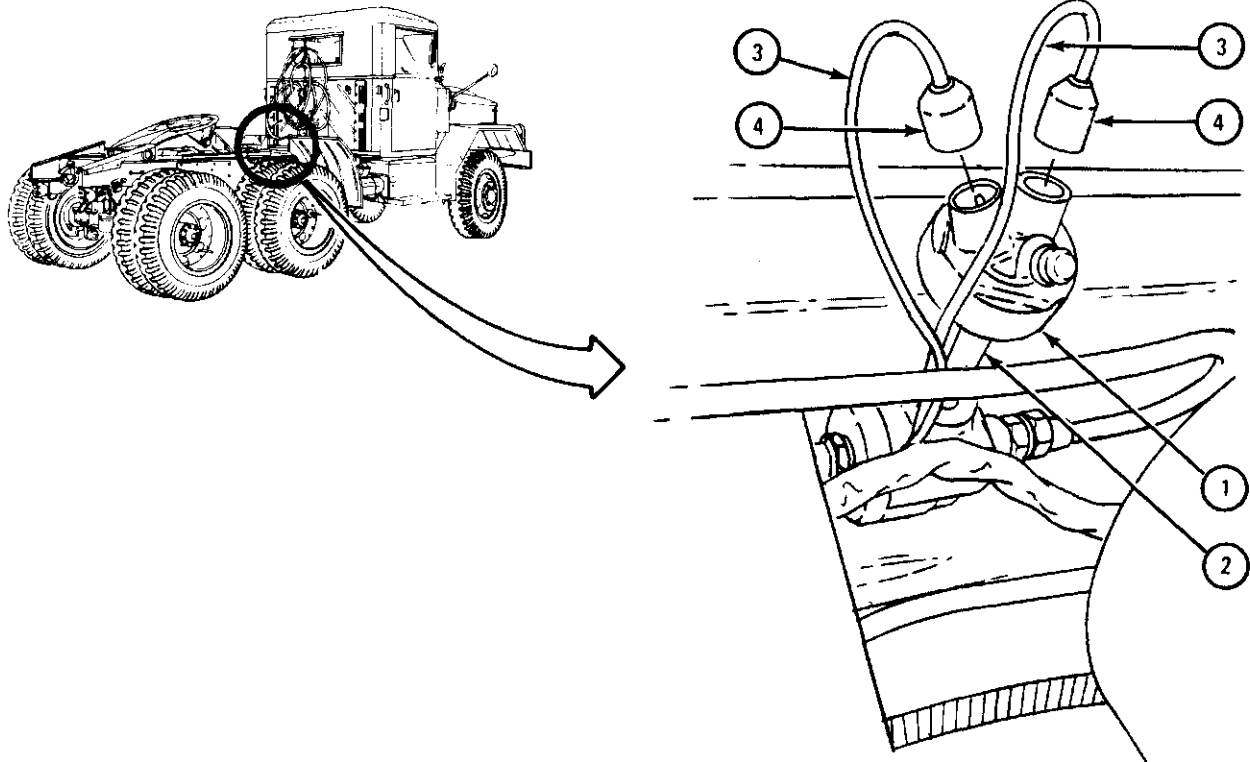

TA 047276

FRAME 2

NOTE

Before taking off electrical plugs (1), tag each plug so it will be put back in right place.

1. Take off two electrical plugs (1).
2. Using 5/8-inch open end wrench, unscrew tube nut (2) and pull air line (3) away from elbow (4).
3. Using 7/16-inch wrench, unscrew two starwasher bolts (5), and take out low air pressure switch (6).
4. Using 1/2-inch wrench, unscrew elbow (4) from low air pressure switch (6).

END OF TASK

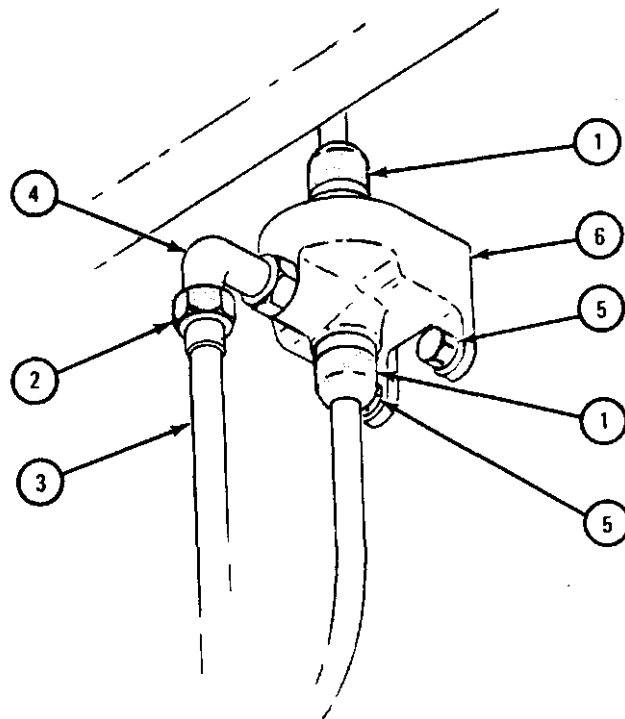

TA 047267

FRAME 3

NOTE

Before taking off electrical plugs (1), tag each plug so it will be put back in right place.

1. Take off two electrical plugs (1).
2. Using 13/16-inch open end wrench, unscrew and take out low air pressure switch (2).

END OF TASK

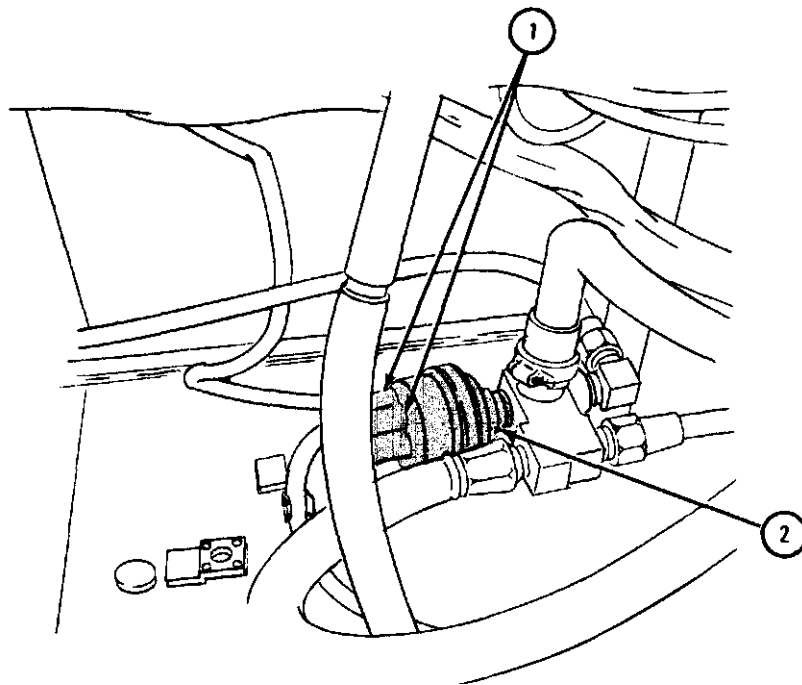

TA 080833

c. Type A Replacement.

FRAME 1

1. Screw elbow (1) into low air pressure switch (2). Using 1/2-inch wrench, tighten elbow and set so end of elbow points down as shown.
2. Aline switch (2) mounting holes with holes in firewall (3). Using 7/16-inch wrench, screw in and tighten two starwasher bolts (4).
3. Join air line (5) to elbow (1). Using 5/8-inch wrench, tighten tube nut (6).

NOTE

Check tags put on plugs (7) during removal so that plugs are put back in right place.

4. Put two electrical plugs (7) into receptacles on switch (2). Take off tags.

NOTE

Follow-on Maintenance Action Required:

Start engine and check operation of low air pressure buzzer. Refer to TM 9-2320-209-10.

END OF TASK

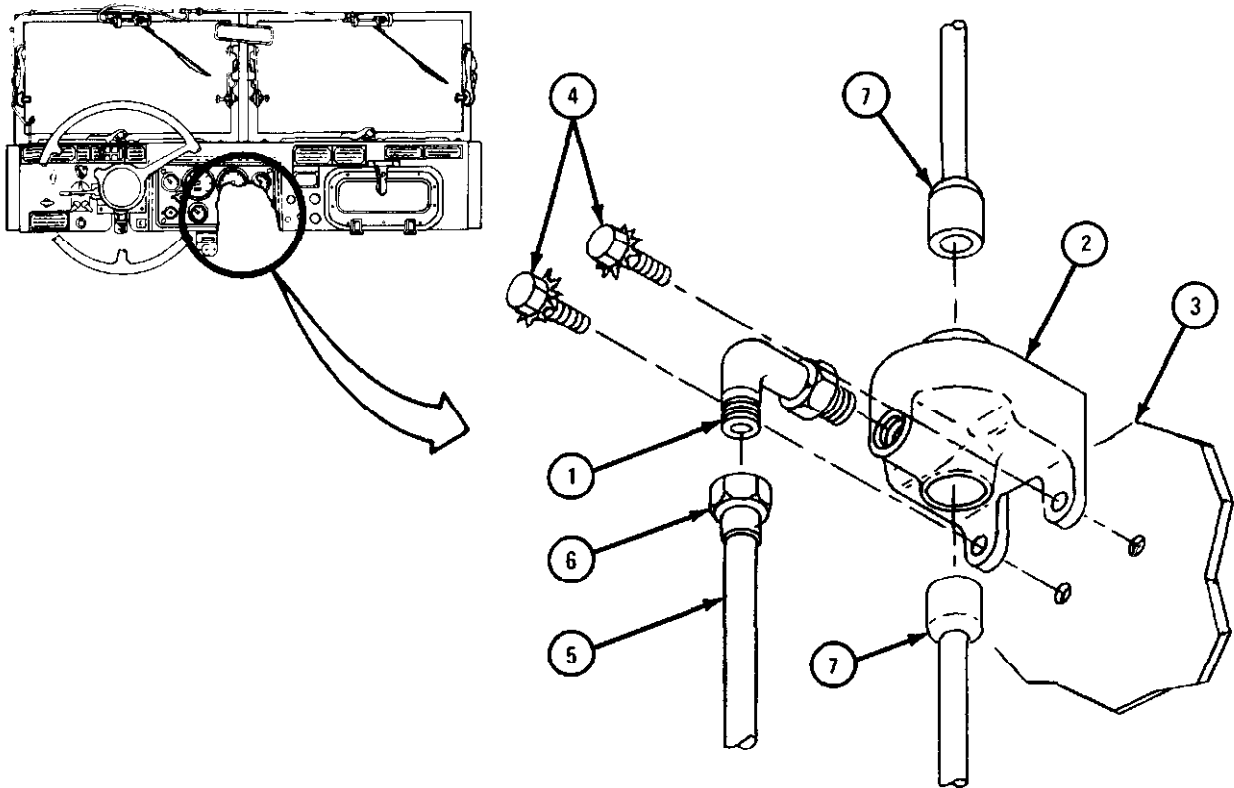

TA 047268

d. Type B Replacement.

FRAME 1

1. Using 13/16-inch open end wrench, screw in and tighten low air pressure switch (1) into tube and hose manifold (2).

NOTE

Check tags put on plugs (3) so that plugs are put back in right place.

2. Put two electrical plugs (3) into receptacles on switch (1). Take off tags.

NOTE

Follow-on Maintenance Action Required:

Start engine and check operation of low air pressure buzzer. Refer to TM 9-2320-209-10.

END OF TASK

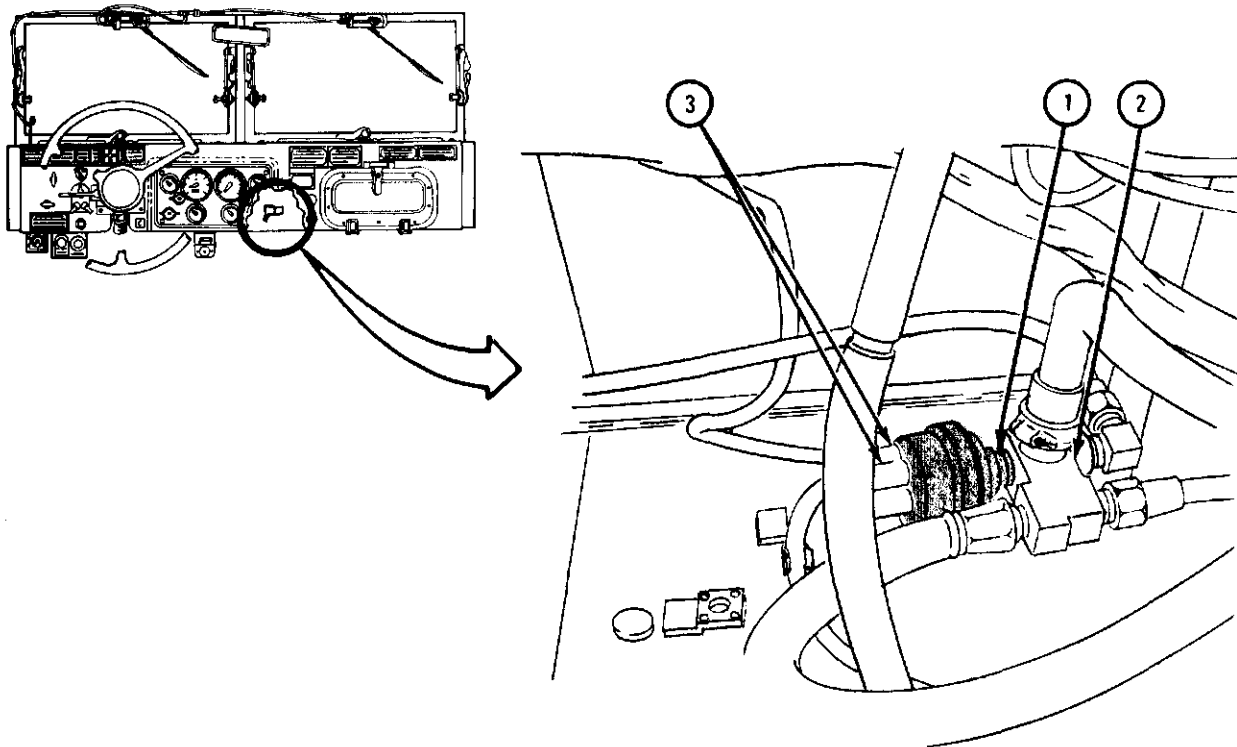

TA 080834

CHAPTER 8

TRANSMISSION SYSTEM GROUP MAINTENANCE

Section I. SCOPE

8-1. EQUIPMENT ITEMS COVERED. This chapter gives equipment maintenance procedures for the transmission breather for which there are authorized corrective maintenance tasks at the organizational maintenance level.

8-2. EQUIPMENT ITEMS NOT COVERED. All equipment items for which corrective maintenance is authorized at the organizational maintenance level are covered in this chapter.

Section II. TRANSMISSION BREATHER

8-3. TRANSMISSION BREATHER REMOVAL AND REPLACEMENT.

TOOLS: Cross-tip screwdriver (Phillips type)
7/16-inch wrench

SUPPLIES: Solvent, dry cleaning, type II (SD-2), Fed. Spec P-D-680
Rag

PERSONNEL: One

EQUIPMENT CONDITION: Truck parked, engine off, handbrake set.

a. Preliminary Procedure. Remove intermediate tunnel, front transmission gear shift lever, and boot. Refer to Part 3, para 18-5.

b. Removal.

FRAME 1

1. Using wrench, unscrew and take transmission breather (1) from transmission housing cover (2).

END OF TASK

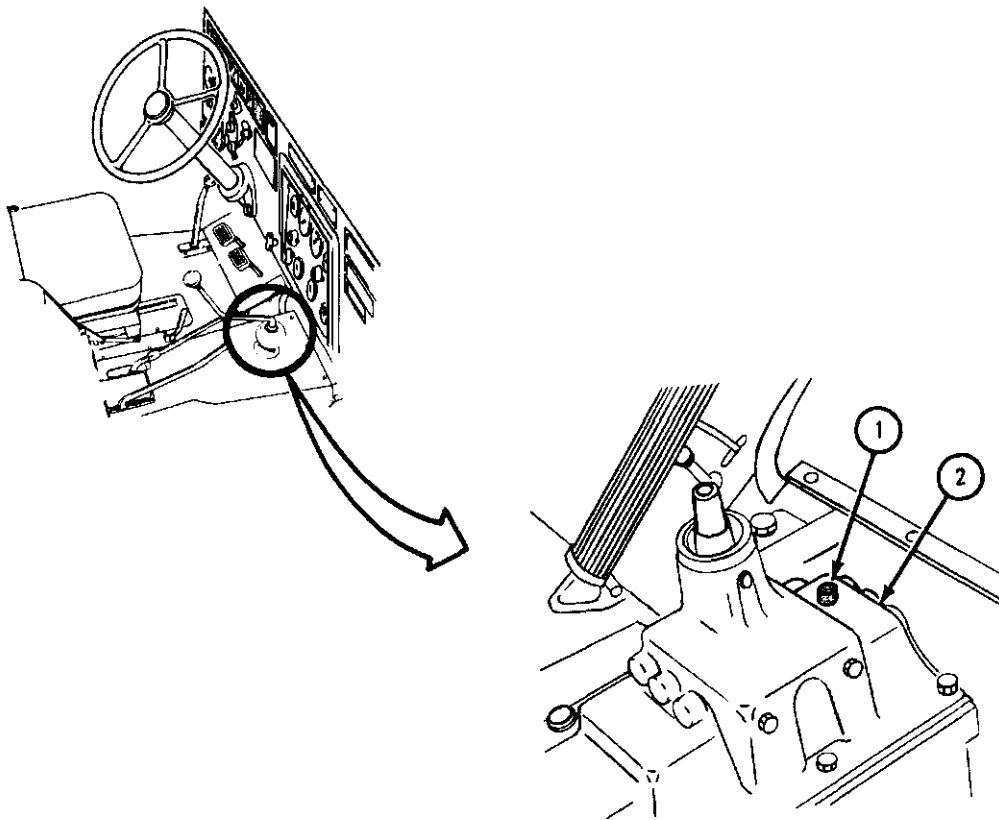

.TA 047432

c. Replacement.

FRAME 1

WARNING

Dry cleaning solvent is flammable. Do not use near an open flame. Keep a fire extinguisher nearby when solvent is used. Use only in well-ventilated places. Failure to do this may result in injury to personnel and damage to equipment.

1. Clean transmission breather (1) with solvent.
2. Using rag, wipe surface clean around transmission breather mounting hole in transmission housing cover (2).
3. Using wrench, screw in and tighten transmission breather (1).

NOTE

Follow-on Maintenance Action Required:

Replace intermediate tunnel, front transmission gearshift lever, and boot. Refer to Part 3, para 18-5.

END OF TASK

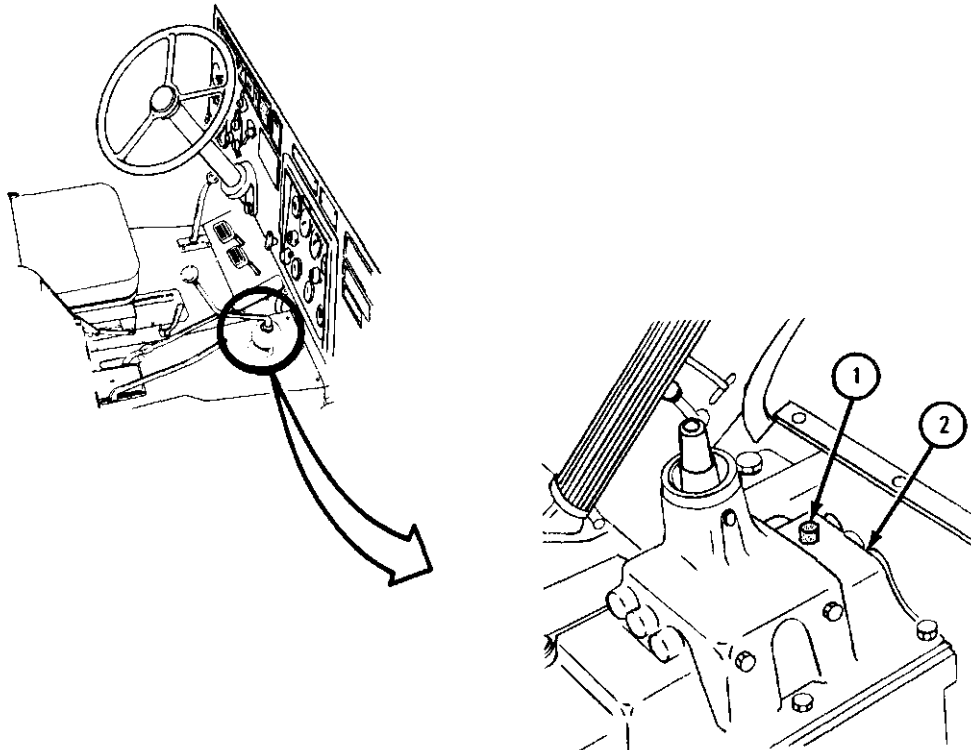

TA 047433

CHAPTER 9

TRANSMISSION TRANSFER SYSTEM GROUP MAINTENANCE

Section I. SCOPE

9-1. **EQUIPMENT ITEMS COVERED.** This chapter gives equipment maintenance procedures for the transmission transfer control and linkage assembly for which there are authorized corrective maintenance tasks at the organizational maintenance level.

9-2. **EQUIPMENT ITEMS NOT COVERED.** All equipment items for which corrective maintenance is authorized at the organizational maintenance level are covered in this chapter.

Section II. TRANSMISSION TRANSFER CONTROL AND LINKAGE ASSEMBLY

9-3. **TRANSMISSION TRANSFER CONTROLS AND LINKAGE WITH POWER TAKEOFF REMOVAL AND REPLACEMENT (TRUCKS M49A1C, M49A2C, M50A1, M50A2, M50A3, M756A2, and M764).**

NOTE

Procedures given are the same for both air actuated positive lockup transmission transfer with power takeoff, and non air actuated positive lockup transmission transfer with power takeoff, except where noted.

<p>TOOLS: 3/4-inch socket wrench 3/4-inch open end wrench 18-inch ruler Needle nose pliers Drift punch</p>	<p>Vise grip pliers Small hammer 13/16-inch open end wrench 5/8-inch wrench</p>
---	--

SUPPLIES: None

PERSONNEL: Two

EQUIPMENT CONDITION: Truck parked, engine off, handbrake set.

a. Preliminary Procedure. Remove intermediate and rear tunnels. Refer to Part 3, para 18-5.

b. Removal of Transmission Shift Lever and Linkage (Trucks M756A2 and M764). Refer to para 9-4.

c. Removal of Transmission Transfer Shift Lever and Linkage (Trucks M49A1C, M49A2C, M50A1, M50A2, and M50A3).

FRAME 1

1. Place power takeoff shift lever (1) in NEUTRAL position and lock by turning shift lever lock (2) parallel with shift lever as shown.
2. Using 3/4-inch wrenches, hold shoulder bolt (3) and unscrew locknut (4). Take out bolt.

GO TO FRAME 2

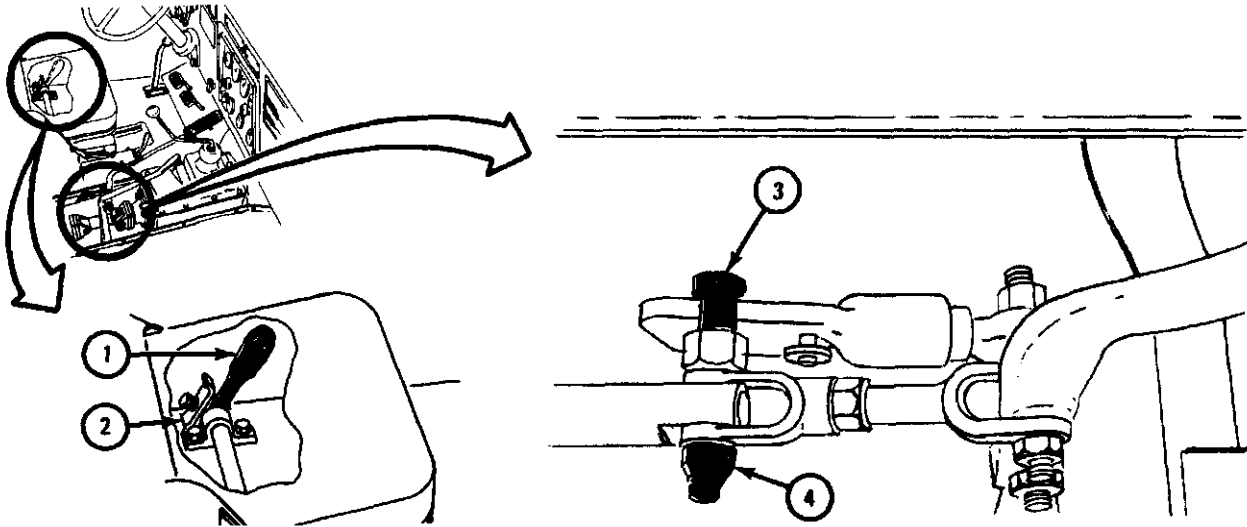

TA 047364

FRAME 2

1. Using 3/4-inch wrenches, unscrew and take off locknut (1) and bolt (2).
2. Hold shifting lever (3) and, using needle nose pliers, take out cotter pin (4) and washer (5). Lift out shift lever link (6).
3. Using 3/4-inch wrenches, unscrew two locknuts (7) from shoulder pin (8). Take out shoulder pin and lift out shifting lever (3).

END OF TASK

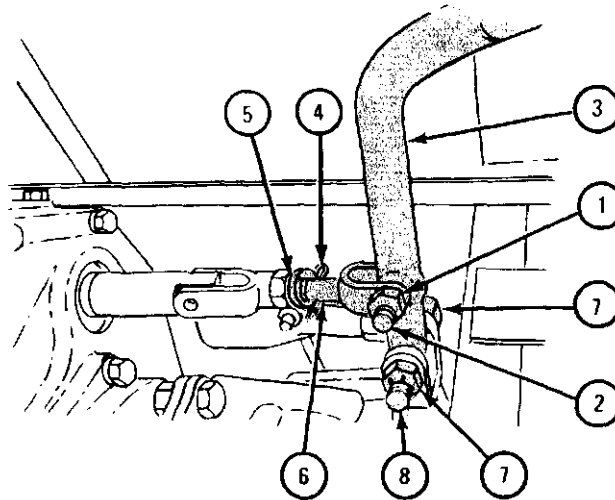

TA 047365

d. Removal of Transmission Transfer Reverse Shift Linkage (Transmission Transfers Without Air Actuated Positive Lockup). Refer to para 9-4.

e. Removal of Power Takeoff Shift Controls and Linkage.

FRAME 1

1. Using 5/8-inch wrench, hold two nuts (1).
2. Using 3/4-inch wrench, unscrew and take off two locknuts (2).
3. Take off link assembly (3).

END OF TASK

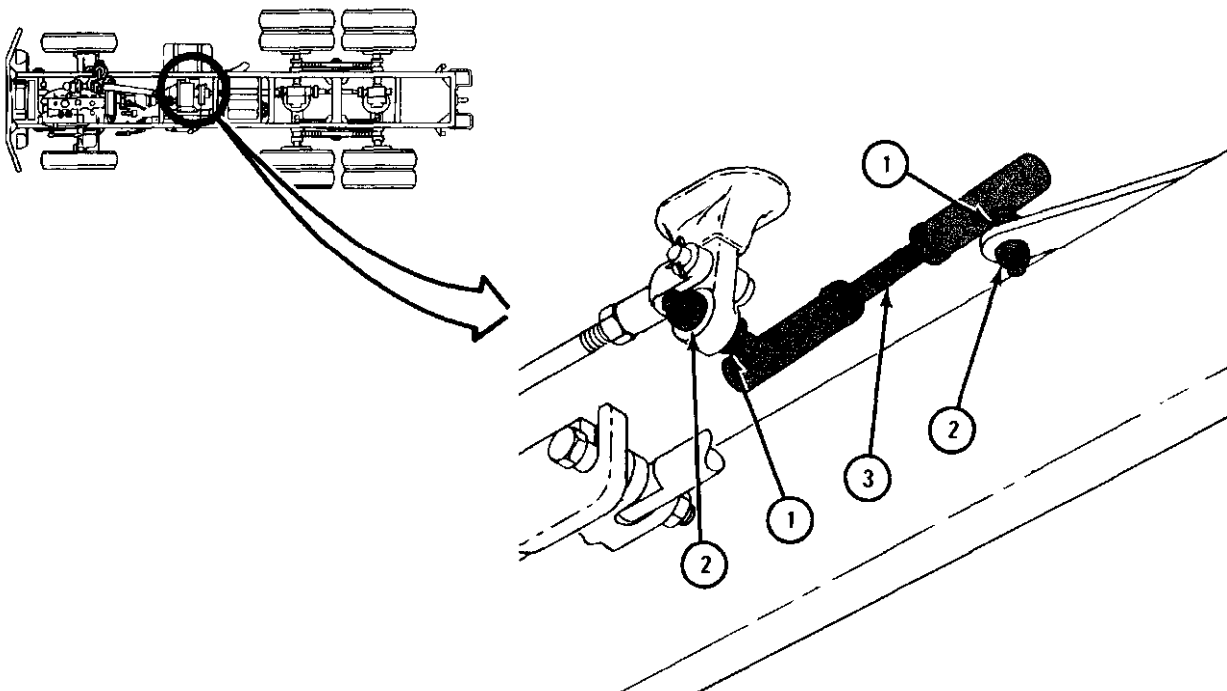

TA 047366

f. Removal of Transmission Transfer Power Takeoff Shifting Lever Lockout Linkage (Trucks M49A1C, M49A2C, M50A1, M50A2, and M50A3).

FRAME 1

1. Using needle nose pliers, take cotter pin (1) out of straight headed pin (2) and take out straight headed pin.

NOTE

Some model trucks have setscrew holding pin in forward end of control rod (3) instead of cotter pin (4). If so, unscrew setscrew to take off control rod.

2. Using needle nose pliers, take cotter pin (4) out of swivel pin (5). Hold control rod (3) while taking out swivel pin and take off control rod.
3. Let swivel pin (5) hang on speed control wire (6) until control rod (3) is put back on truck.

GO TO FRAME 2

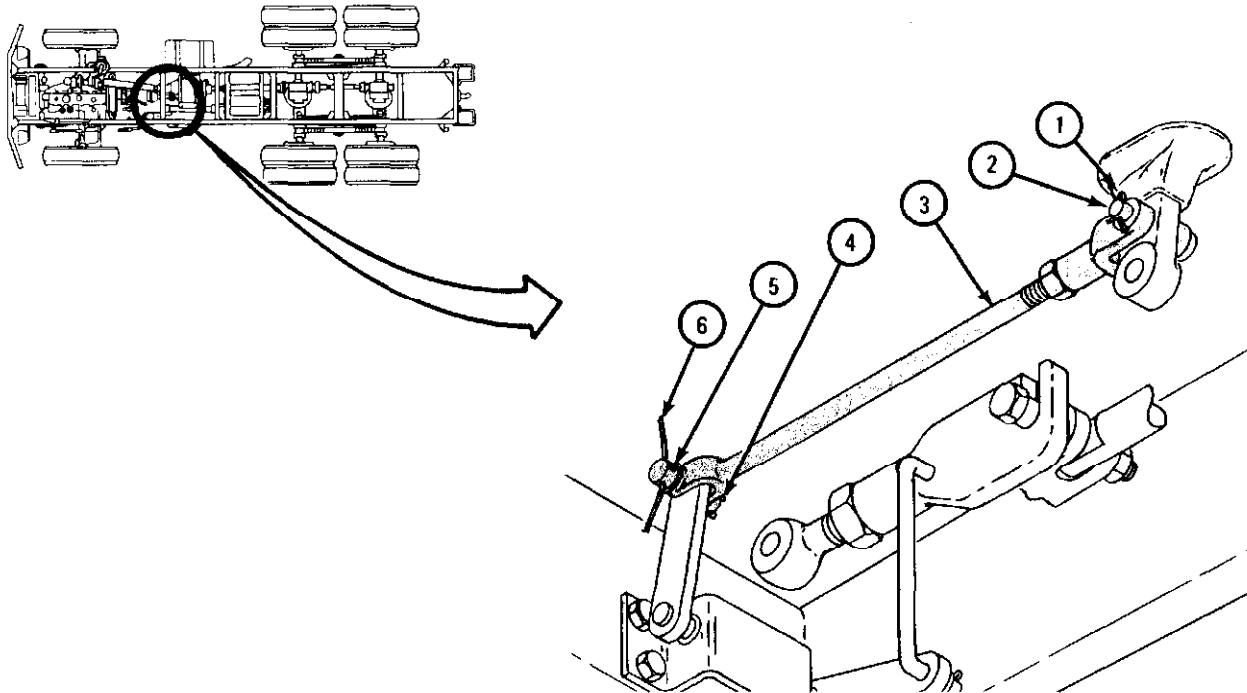

TA 047367

FRAME 2

1. Using needle nose pliers, take cotter pin (1) out of rod (2) and take off flat washer (3).
2. Using needle nose pliers, take cotter pin (4) out of rod (2) and take off flat washer (5).

GO TO FRAME 3

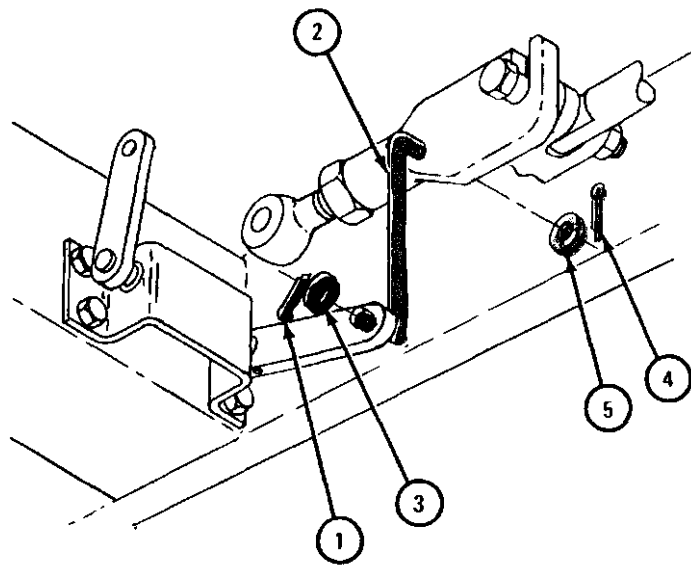

TA 047368

FRAME 3

1. Using small hammer and drift punch, drive spring pin (1) out of lockout shaft lever (2). Pull lockout shaft lever off lockout shaft assembly (3).
2. Pull lockout shaft assembly (3) out of bracket (4).

END OF TASK

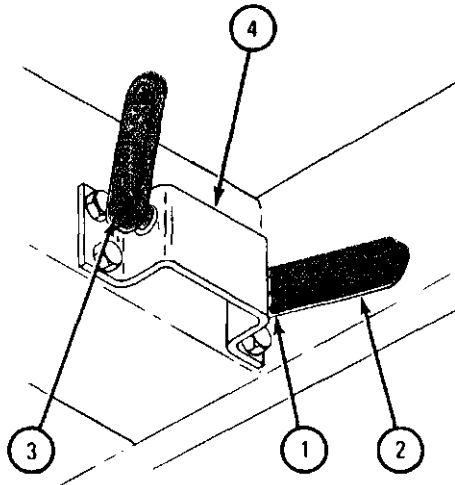

TA 047369

g. Repair of Transmission Transfer Controls and Linkage. Repair transmission transfer controls and linkage by welding, straightening or replacing bent or damaged parts.

h. Replacement of Transmission Transfer Shift Lever and Linkage (Trucks M49A1C, M49A2C, M50A1, M50A2, and M50A3).

FRAME 1

1. Screw nut (1) and washer (2) on rod (3) and then screw yoke (4) on rod.

NOTE

Do not tighten nut (1) at this time. It will be tightened after setting length of rod (3) on transfer.

GO TO FRAME 2

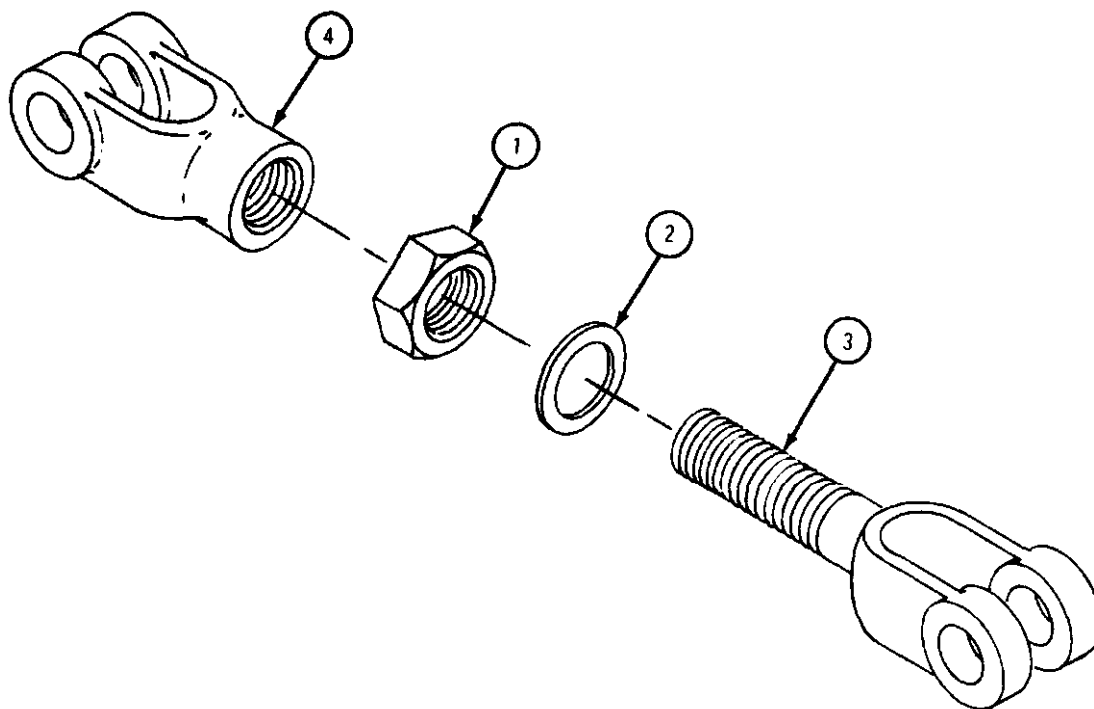

TA 086607

FRAME 2

1. Put shifting lever (1) in yoke of bracket (2) as shown.
2. Put shoulder pin (3) through lockout arm (4), bracket (2) and bottom hole in shifting lever (1).
3. Screw locknuts (5) on each end of shoulder pin (3) and tighten, using 3/4-inch wrenches.

NOTE

Lockout arm (4) will be joined to lockout linkage after this procedure is finished.

GO TO FRAME 3

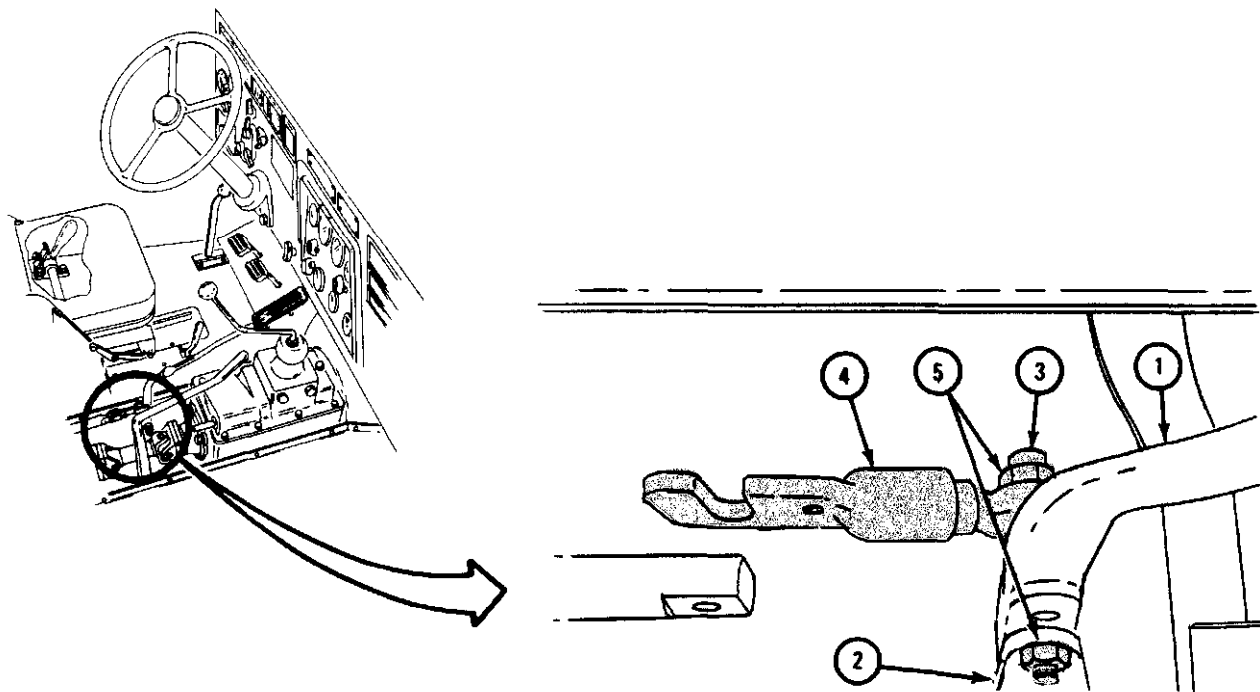

TA 047370

FRAME 3

1. Place shifter link (1) so holes in yoke (2) aline with hole in shifting lever (3).
2. Put bolt (4) through yoke (2) and shifting lever (3) and screw on locknut (5).
3. Using 3/4-inch wrenches, tighten locknut (5).

GO TO FRAME 4

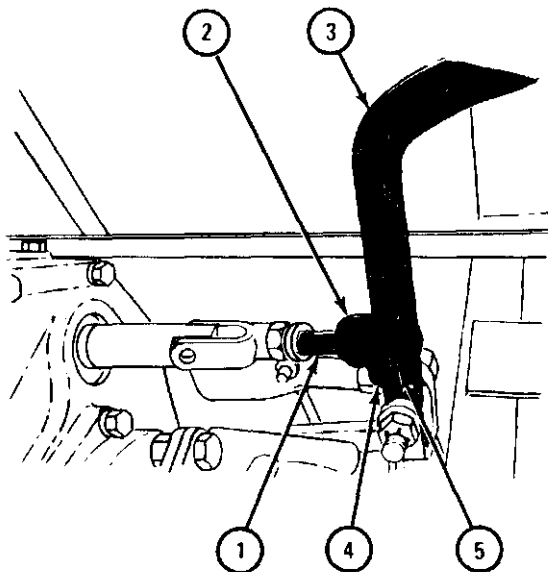

TA 047371

FRAME 4

1. Place rear tunnel (1) over transfer shifting lever (2) and align tunnel mounting holes with floor holes.
2. Set transfer shifting lever (2) down to LOW position to get 1/4-to-1/2-inch clearance from top of rear tunnel. This distance is measured at point (A) as shown.
3. Using ruler, measure distance from top of transfer shifting lever (2) to top of crossbrace (3) as shown.
4. Take rear tunnel (1) out of cab.
5. Using ruler, set transfer shifting lever (2) to same distance from crossbrace (3) as it was in step 3.

GO TO FRAME 5

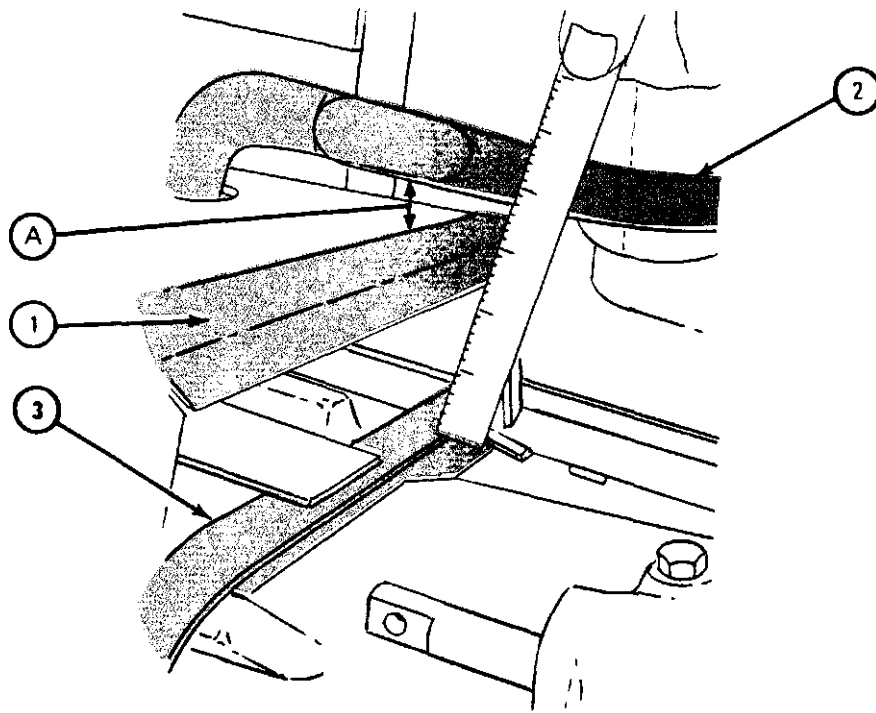

TA 047339

FRAME 5

NOTE

Be very careful not to move shifting lever (1) from the position set in frame 4.

1. Pull shifter shaft (2) out to engage low speed gears. Check that detent action holds shaft in this position.
2. Check if holes in yoke (3) align with hole in shifter shaft (2). If holes do not align, adjust length of rod (4) by screwing yoke (3) onto rod (4) to shorten rod length or unscrewing yoke (3) from rod (4) to make rod longer.
3. When holes in yoke (3) align with hole in shifter shaft (2), put in shoulder bolt (5) as shown. Screw on locknut (6) and tighten using 3/4-inch wrenches.

GO TO FRAME 6

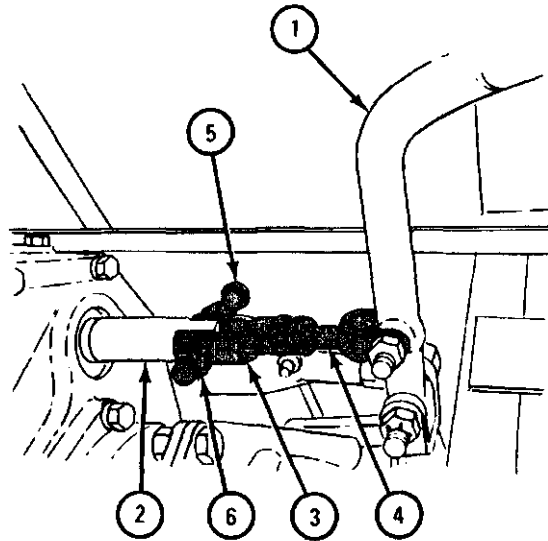

TA 047372

FRAME 6

1. Using 13/16-inch open end wrench, hold yoke (1) and tighten nut (2) with 3/4-inch wrench.
2. Using needle nose pliers, put in cotter pin (3) and bend ends of cotter pin.
3. Move transfer shifting lever (4) to NEUTRAL, HIGH, and LOW positions and feel for detent action. Detent in transfer case should hold transfer shifting lever in each of the three positions.

END OF TASK

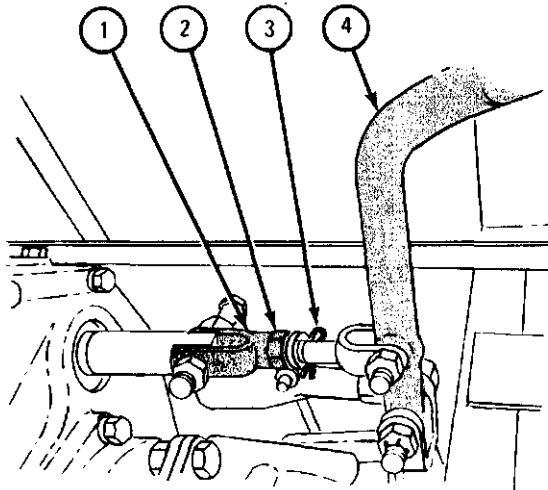

TA 047373

i. Replacement of Transmission Transfer Shift Lever and Linkage (Trucks M756A2 and M764). Refer to para 9-4.

j. Replacement of Transmission Transfer Power Takeoff Shift Controls and Linkage.

FRAME 1

1. Place transfer power takeoff shift lever (1) in NEUTRAL position and lock by placing shift lever lock (2) parallel with transfer power takeoff shift lever as shown.

GO TO FRAME 2

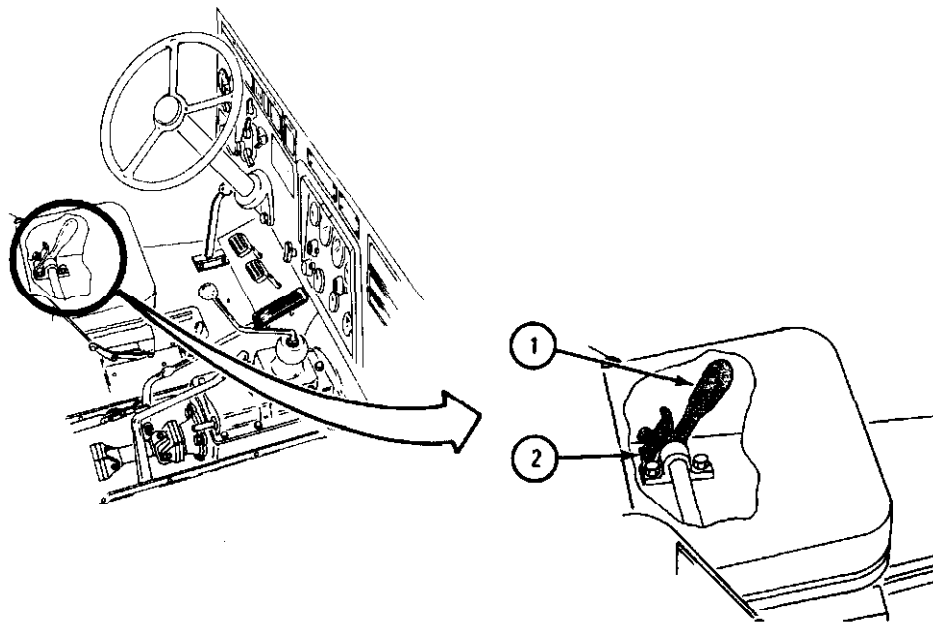

TA 047374

FRAME 2

1. Push shifter shaft lever (1) toward rear of truck as far as it will move. This is neutral position,
2. Place link assembly (2) as shown and check to see if ball joint studs (3) align with holes in shift control lever (4) and shifter shaft lever (1).
3. If ball joint studs (3) align and seat firmly in holes, screw on two locknuts (5). Use one 5/8-inch wrench to hold two studs while tightening two locknuts with 3/4-inch wrench.
4. If ball joint studs (3) do not align and seat firmly in holes, do steps 5, 6, and 7 to shorten or lengthen link assembly (2).
5. Using 3/4-inch wrenches, loosen two jamnuts (6).
6. Using vise grip pliers, turn link assembly (2) left or right as necessary until ball joint studs (3) align with holes.
7. Using 3/4-inch wrenches, tighten two jamnuts (6) and do step 3 again.

END OF TASK

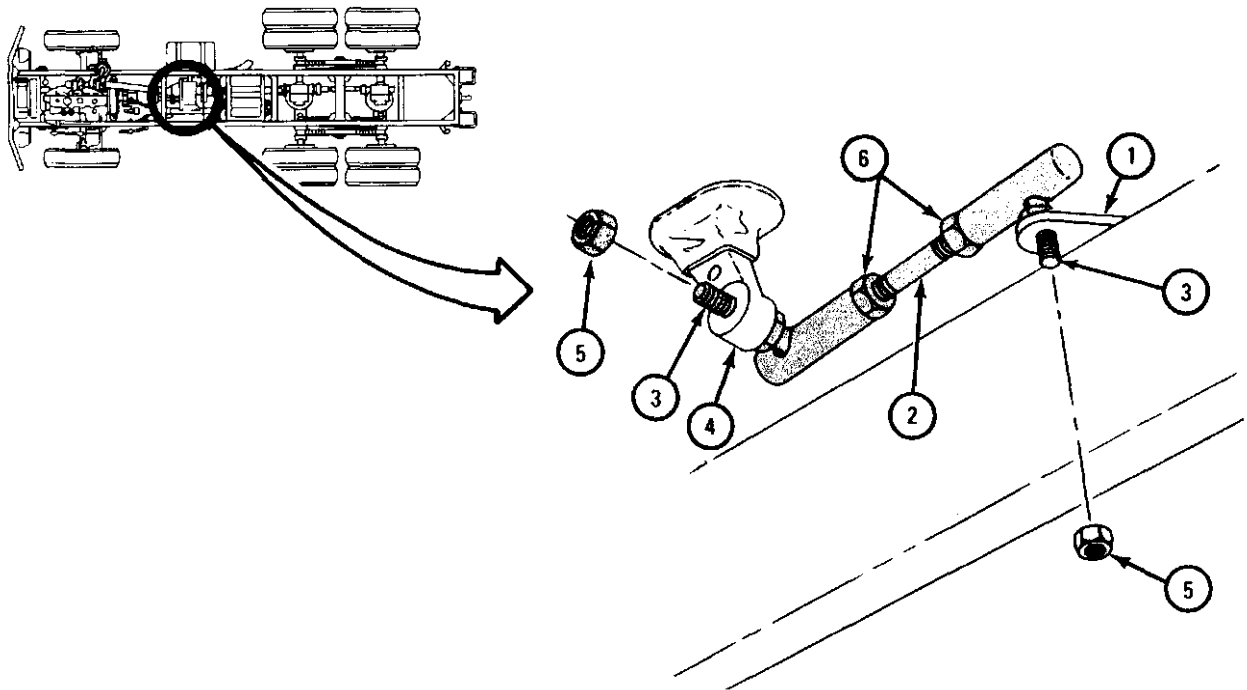

TA 047375

k. Replacement of Transmission Transfer Power Takeoff Shifting Lever Lockout Linkage (Trucks M49A1C, M49A2C, M50A1, M50A2, and M50A3).

FRAME 1

1. Unlock transfer power takeoff shift lever (1) by putting shift lever lock (2) crosswise to transfer power takeoff shift lever as shown.
2. Pull transfer power takeoff shift lever (1) back to ENGAGED position.
3. Place shifting lever (3) to NEUTRAL position.

GO TO FRAME 2

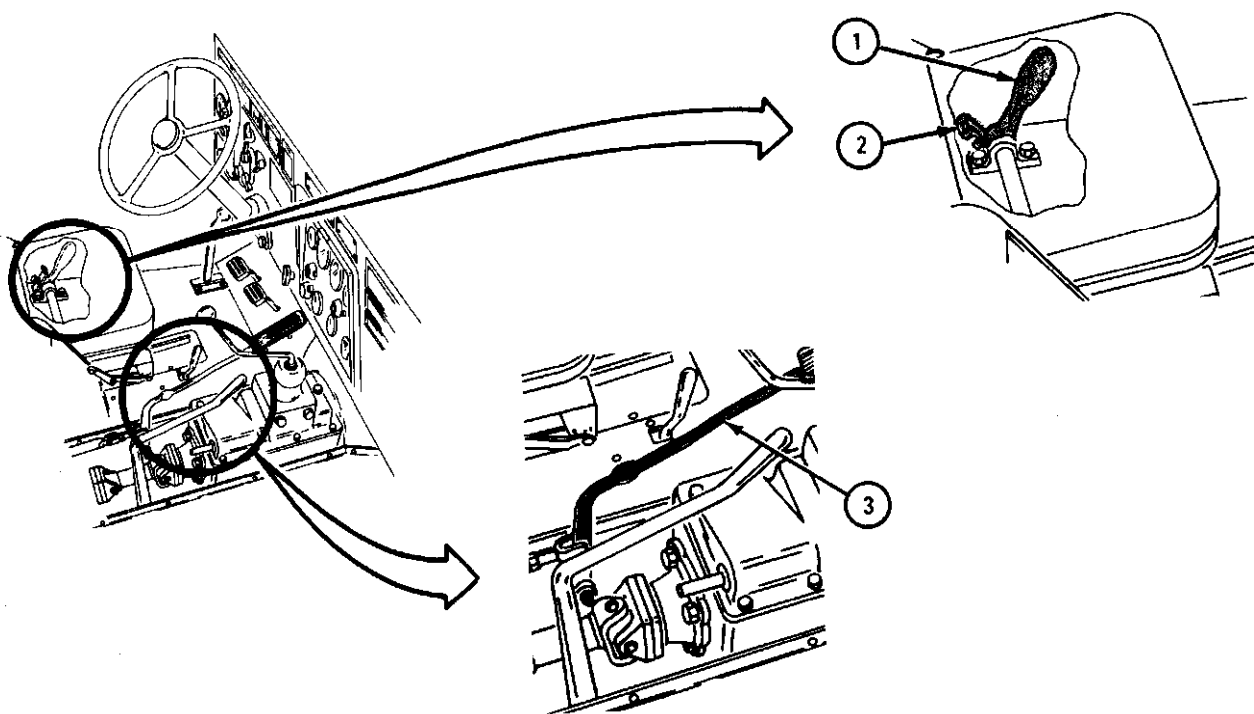

TA 047376

FRAME 2

- Soldier A
1. From under truck, put lockout shaft (1) in bracket (2) from left side of bracket as shown.
 2. Put lockout shaft lever (3) on end of lockout shaft (1) on right side of bracket (2).

NOTE

When lever on locknut shaft (1) is pointing up, lockout shaft lever (3) must point to rear of truck. Lockout shaft lever (3) should be almost horizontal.

3. Aline hole in lockout shaft lever (3) with hole in lockout shaft (1). Tell soldier B when ready.

- Soldier B
4. Working in cab, when soldier A is ready, using small hammer, carefully tap spring pin (4) into hole in locknut shaft lever (3).

GO TO FRAME 3

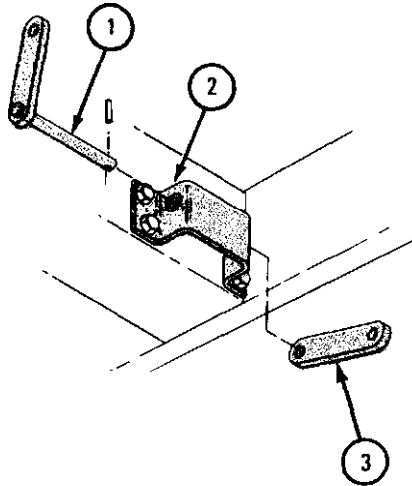
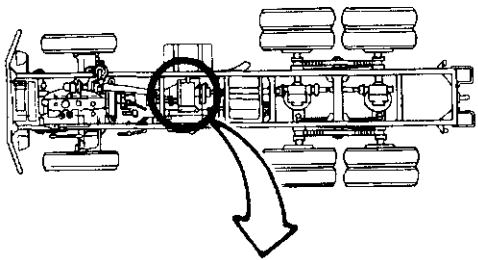

SOLDIER A

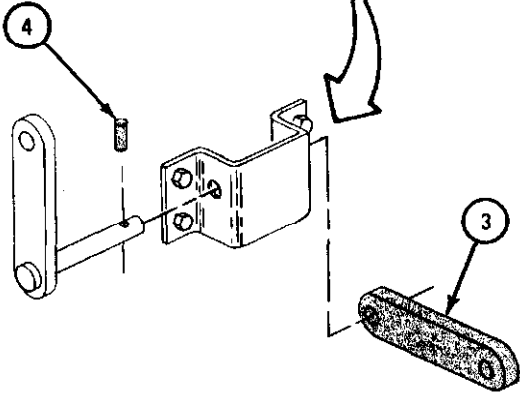
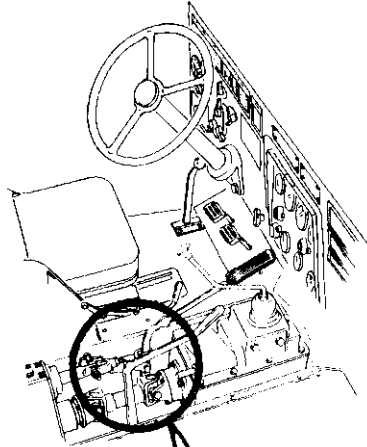

SOLDIER B

TA 047377

FRAME 3

1. Put end of rod (1) through hole in lockout arm (2) as shown.
2. Put flat washer (3) on end of rod (1). Using pliers, put cotter pin (4) through hole in rod and spread ends.
3. Put other end of rod (1) through hole in lockout shaft lever (5).
4. Put flat washer (6) on end of rod (1). Using pliers, put cotter pin (7) through hole in rod and spread ends.

GO TO FRAME 4

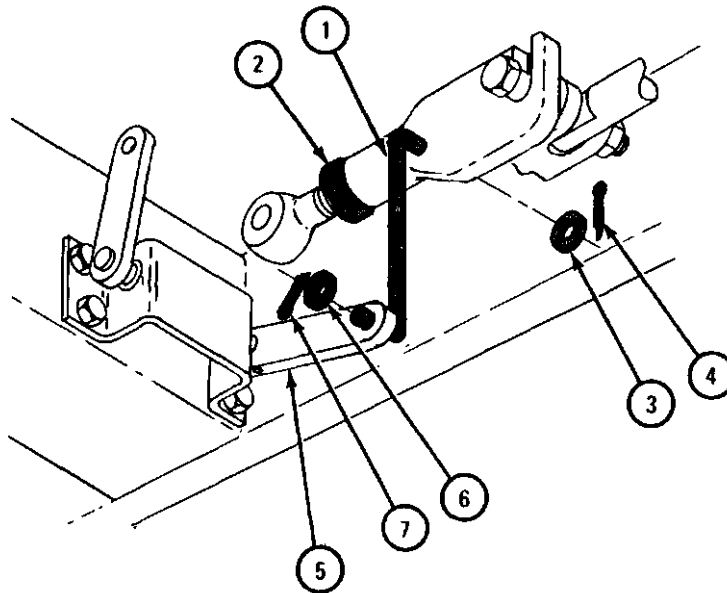

TA 047378

FRAME 4

1. Place control rod (1) under truck as shown and aline holes in clevis (2) with upper hole in shift control lever (3).
2. Put straight headed pin (4) through clevis (2).
3. Using needle nose pliers, put cotter pin (5) through hole in straight headed pin (4) and spread ends.

GO TO FRAME 5

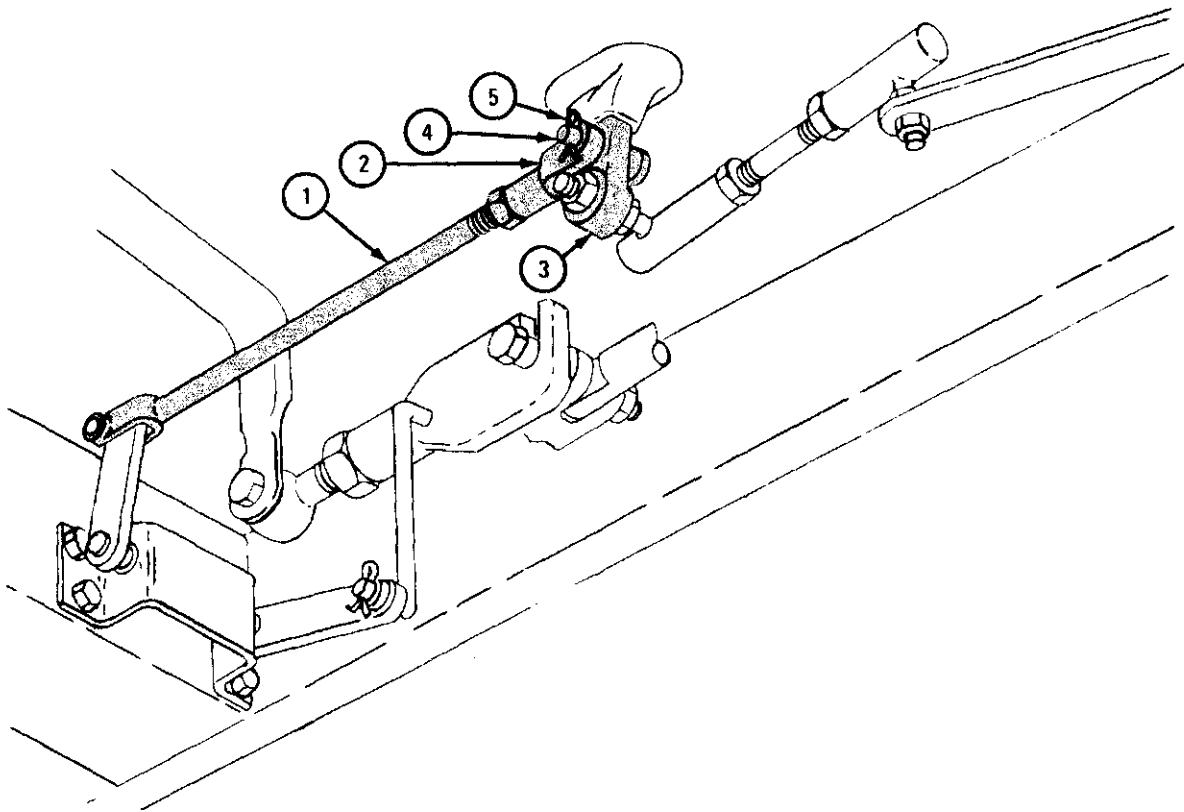

TA 047379

FRAME 5

1. Push lockout arm (1) up until shoulder bolt (2) is firmly seated at bottom of slot in lockout arm, locking transfer in neutral.
2. While holding lockout arm (1) up, check alinement of holes in clevis (3) with hole in lockout shaft lever (4).
3. If holes do not line up, do steps 4 and 5 to shorten or lengthen control rod (5).
4. Using 5/8-inch wrench, loosen jamnut (6).
5. Screw control rod (5) into clevis (7) to shorten control rod. Unscrew control rod (5) from clevis (7) to make control rod longer.

IF CONTROL ROD (5) CANNOT BE MADE LONG ENOUGH TO ALINE HOLES,
GO TO FRAME 6.

IF CONTROL ROD (5) CAN BE ADJUSTED TO ALINE HOLES, GO TO FRAME 7

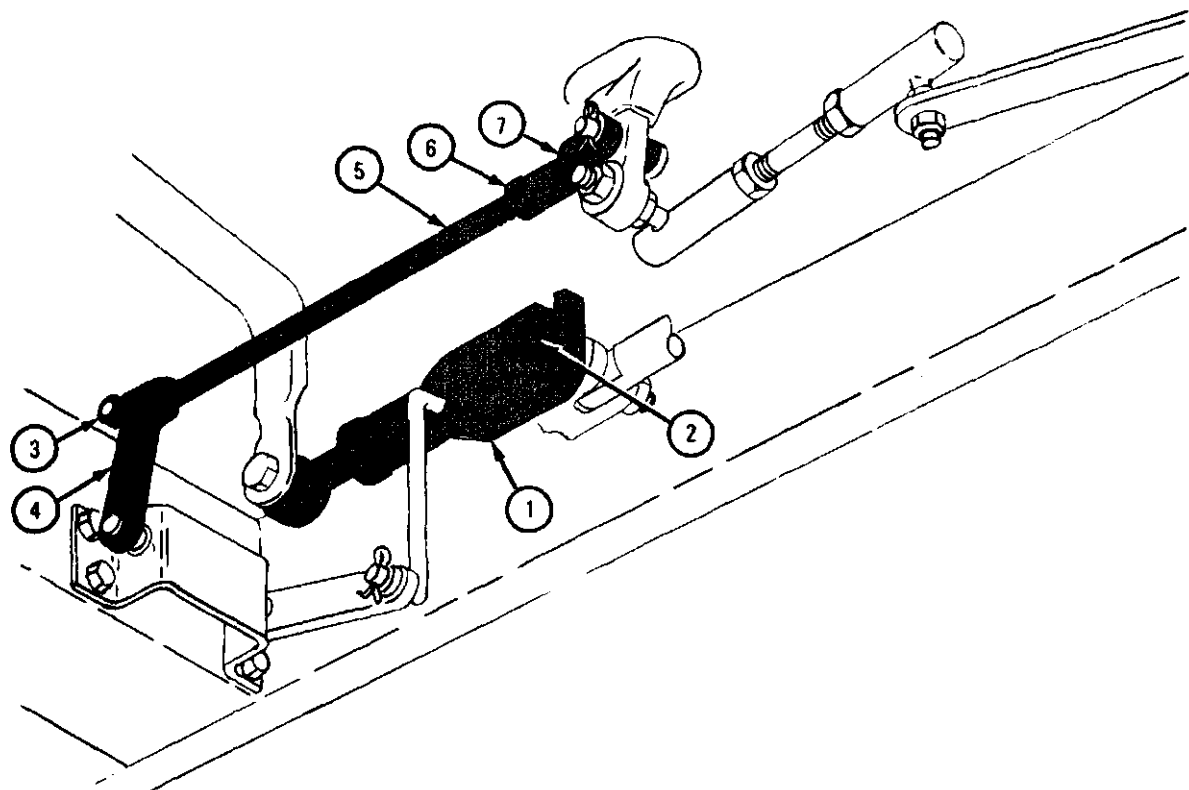

TA 047380

FRAME 6

1. Using 3/4-inch wrenches, loosen two jamnuts (1).

NOTE

When turning rod (2) of link assembly (3), make sure that shifter shaft (4) stays forward in engaged position.

2. Using vise grip pliers, turn rod (2) in direction which makes link assembly (3) longer. When holes in clevis (5) align with hole in lockout shaft lever (6), tighten two jamnuts (1), using 3/4-inch wrenches.

GO TO FRAME 7

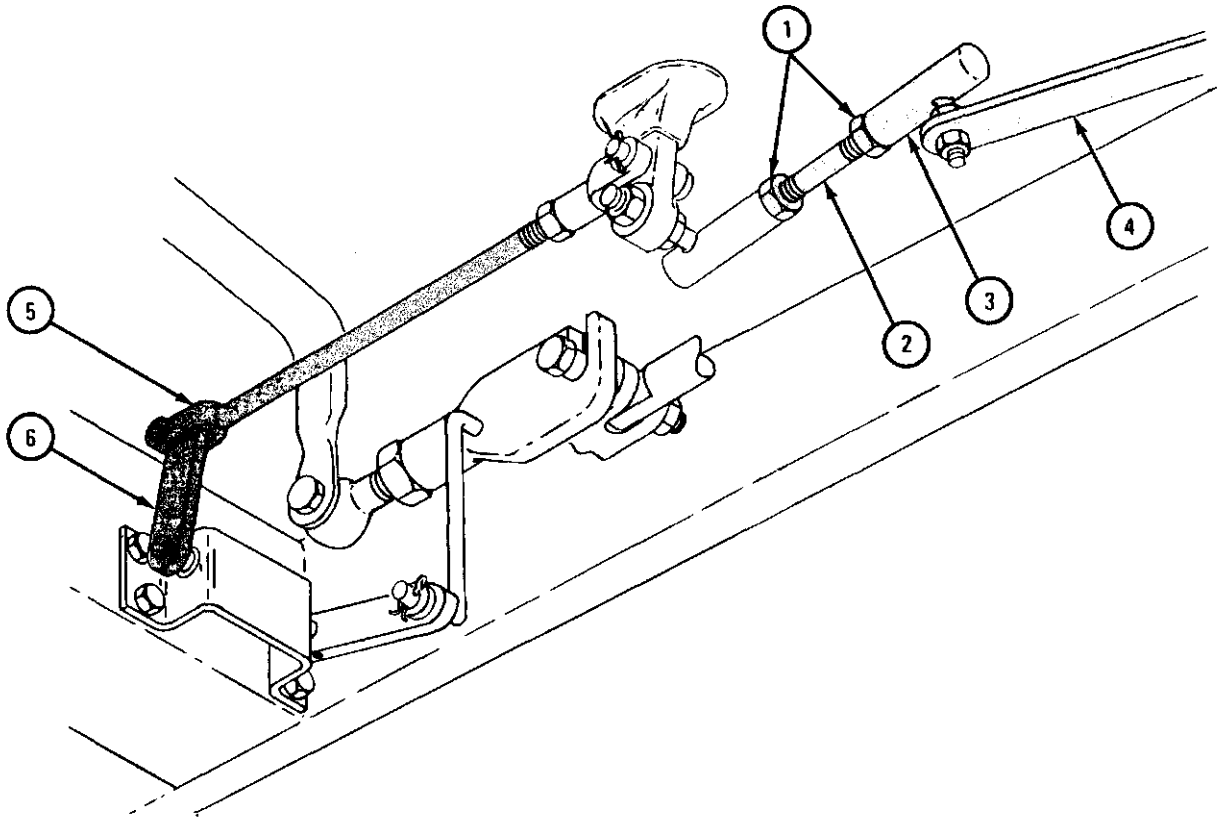

TA 047381

FRAME 7

1. Put swivel pin (1) through holes in clevis (2) and lockout shaft lever (3).
2. Put cotter pin (4) through hole in end of swivel pin (1) and spread ends of cotter pin using pliers.
3. Make sure speed control wire (5) is still through head of swivel pin (1).
4. Using vise grip pliers to hold control rod (6), tighten jamnut (7), using 3/4-inch wrench.

GO TO FRAME 8

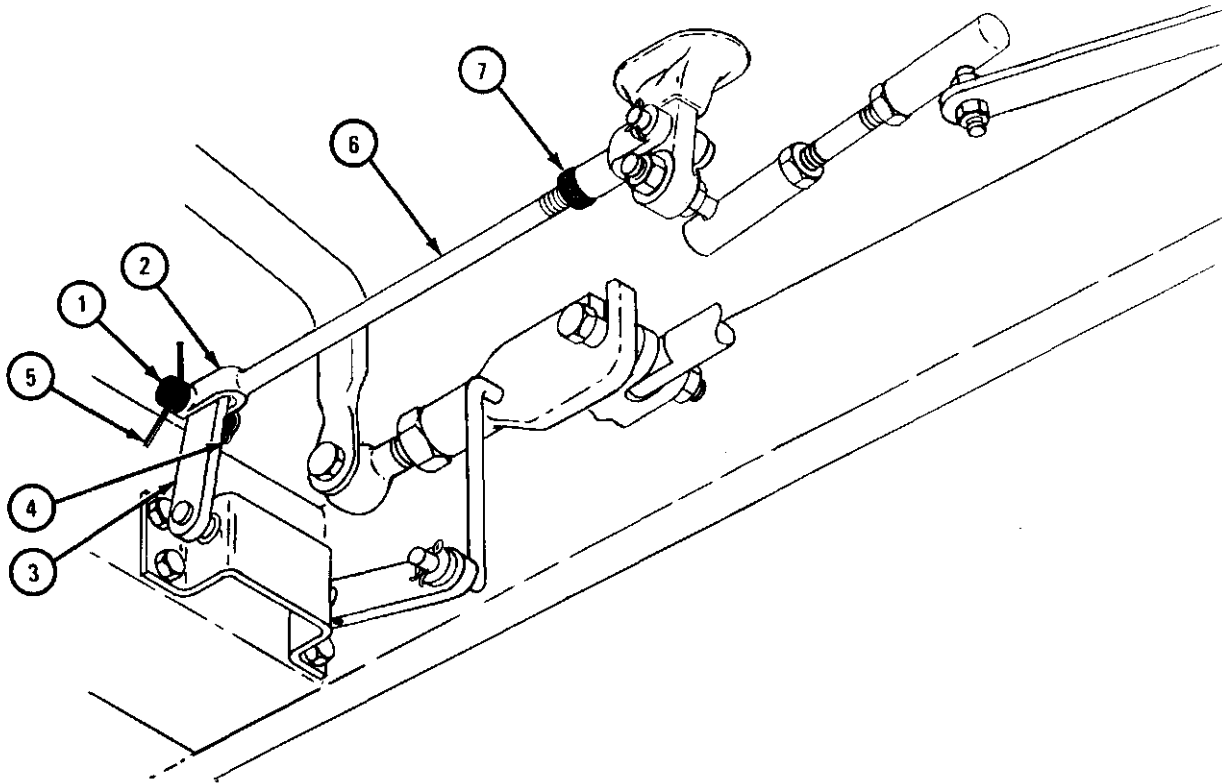

TA 047382

FRAME 8

1. Place transfer power takeoff shift lever (1) in NEUTRAL position.
2. Move transfer shifting lever (2) to LOW, NEUTRAL, and HIGH positions. There should be no binding. Detent action should hold transfer shifting lever in each of the three positions.
3. Place transfer shifting lever (2) to NEUTRAL and place transfer power takeoff shift lever (1) to ENGAGED.
4. Try to move transfer shifting lever (2). It should be locked in NEUTRAL position and should not move.

END OF TASK

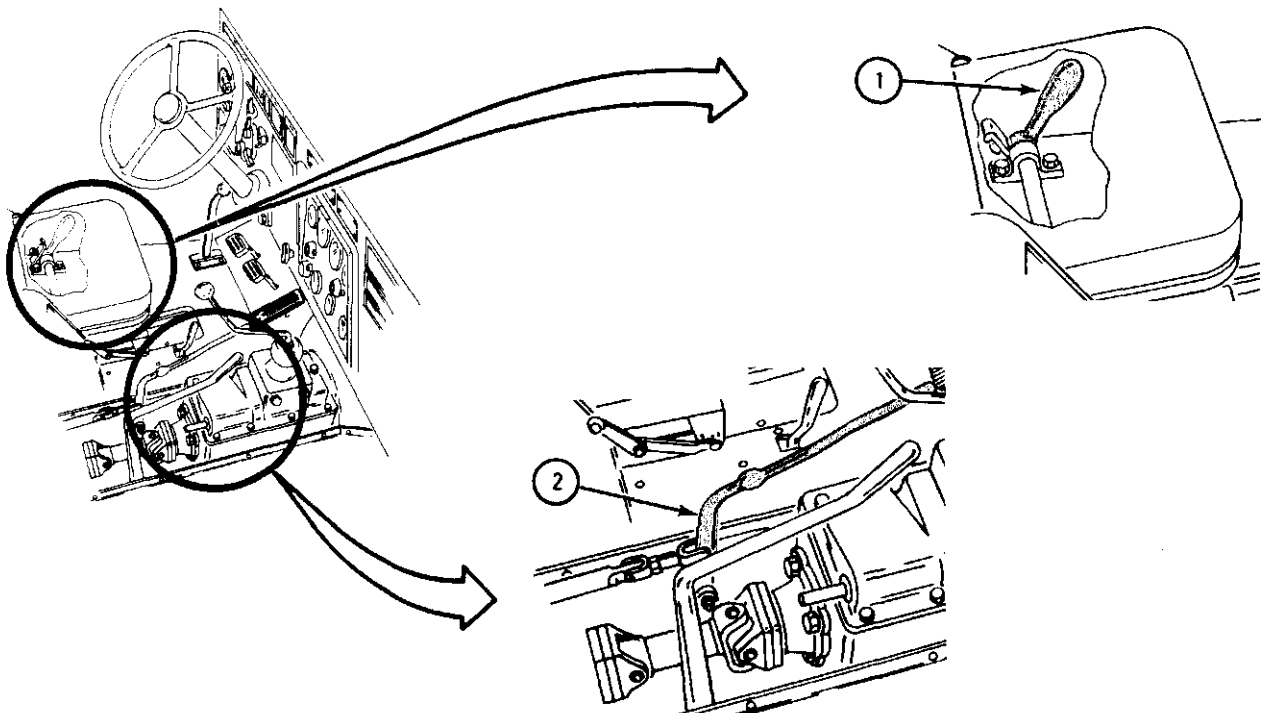

TA 047383

9-4. TRANSMISSION TRANSFER CONTROLS AND LINKAGE (WITHOUT POWER TAKEOFF) REMOVAL, REPAIR, AND REPLACEMENT.

NOTE

Procedures given are the same for both air actuated positive lockup transmission transfer and transmission transfer without air actuated positive lockup, except where noted.

TOOLS:	3/8-inch wrench	8-inch extension
	7/16-inch wrench	Vise
	9/16-inch wrench (2)	Ruler
	3/4-inch wrench (2)	Rolling head prybar
	3/4-inch socket wrench clamp	9/16-inch socket wrench
	Vise grip pliers	Small hammer
	Wood blocks	Jack
		Retaining ring pliers

SUPPLIES: Solvent, dry cleaning, type II (SD-2), Fed. Spec P-D-680

PERSONNEL: Two

EQUIPMENT CONDITION: Truck parked, engine off, handbrake set.

CAUTION

On transmission transfers without air actuated positive lockup, removal of transmission transfer or reverse shift linkage requires complete adjustment of reverse-shift linkage. This is to make sure that double sprag overrunning clutch works correctly. Refer to para 9-6.

- a. Preliminary Procedures. Remove cab tunnels. Refer to Part 3, para 18-5.

b. Removal of Transmission Transfer Shift Lever and Linkage.

FRAME 1

1. Using 3/4-inch wrenches, unscrew and take out two locknuts (1) and bolts (2). Lift out shifter link (3).
2. Using 3/4-inch wrenches, unscrew locknut (4) and take out bolt (5). Lift out shifting lever (6).

GO TO FRAME 2

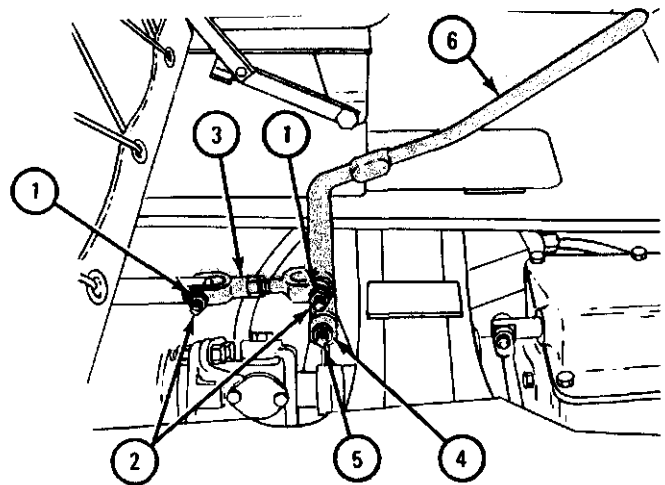
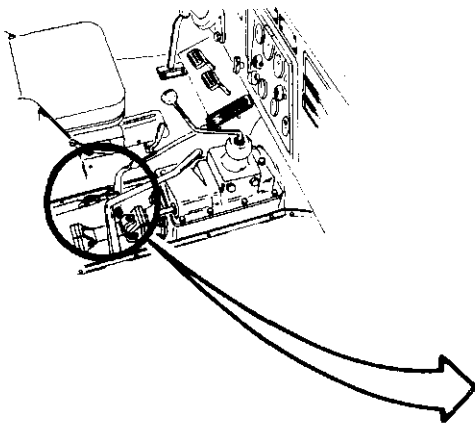

TA 047331

FRAME 2

1. Using vise grip pliers, hold body of yoke (1) and loosen nut (2), using 3/4-inch wrench.
2. Unscrew yoke (1) from rod (3).

END OF TASK

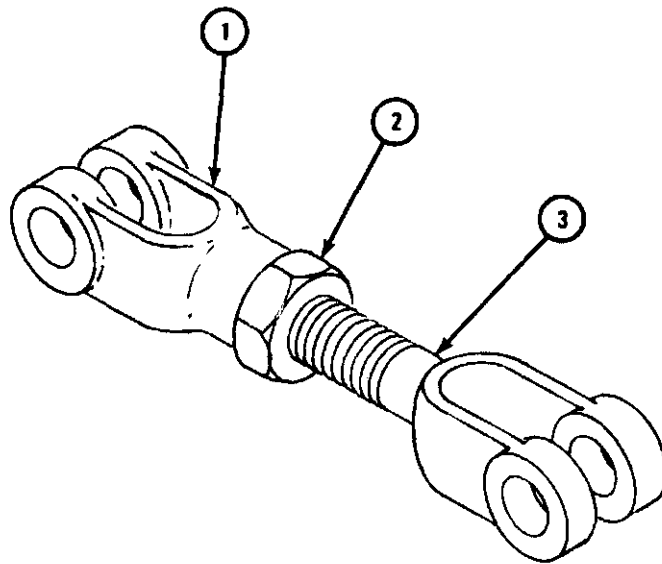

TA 047332

Removal of Transmission Transfer Reverse Shift Lever and Linkage
(Transmission Transfers Without Air Actuated Positive Lockup).

- (1) Preliminary procedures.
 - (a) Jack up either front wheel. Refer to para 11-4.
 - (b) Put front transmission gear shift lever to first gear position.
- (2) Removal.

FRAME 1

NOTE

Grooved pin (1) is held by a spring-loaded ball. Be very careful not to pull pin all the way out of clevis (2).

1. Using pliers, pull grooved pin (1) out of clevis (2) just enough to free clevis from reverse shift lever (3).

GO TO FRAME 2

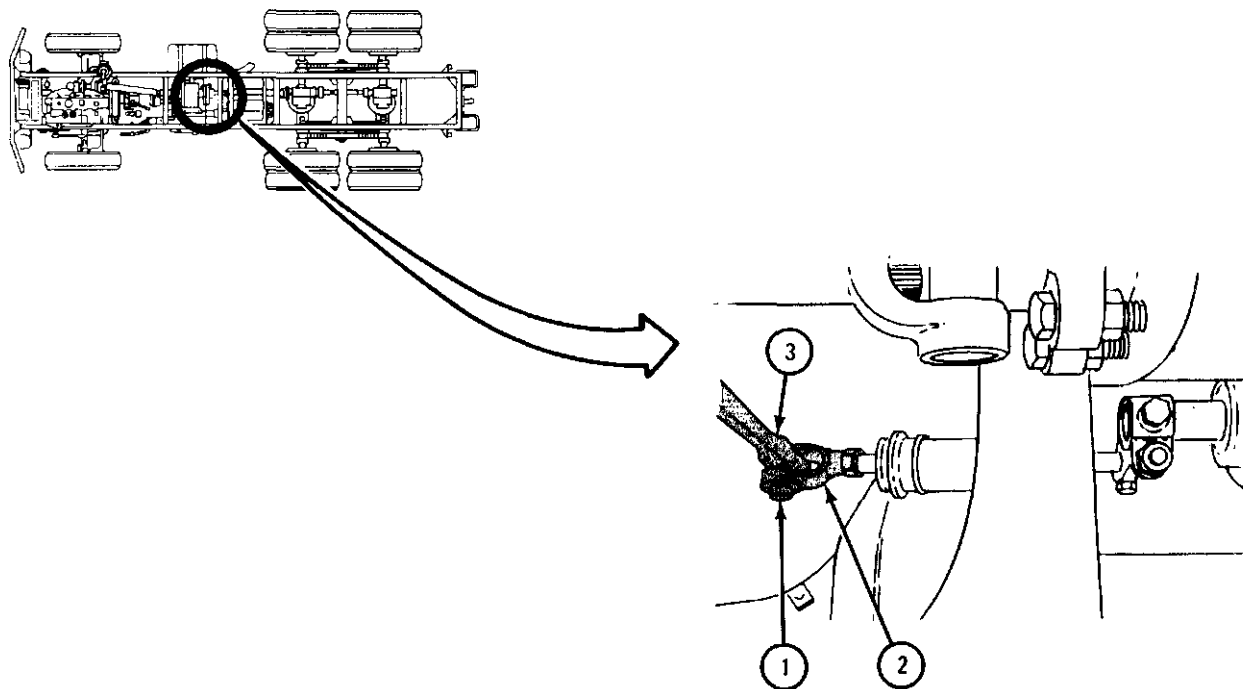

TA 047333

FRAME 2

- Soldier A 1. Working in cab, using 3/4-inch socket wrench, hold bolt (1) on reverse shift rod lever (2). Tell soldier B when ready.
- Soldier B 2. When soldier A is ready, working under truck, using 3/4-inch socket wrench, loosen locknut (3).
3. Using 9/16-inch socket wrench with 8-inch extension, unscrew and take out bolt (4). Tell soldier A when ready.
- Soldier A 4. When soldier B is ready, using vise grip pliers, hold reverse shift rod (5) and slide reverse shift rod lever (2) off end of reverse shift rod. Take out reverse shift rod lever with linkage (6).

GO TO FRAME 3

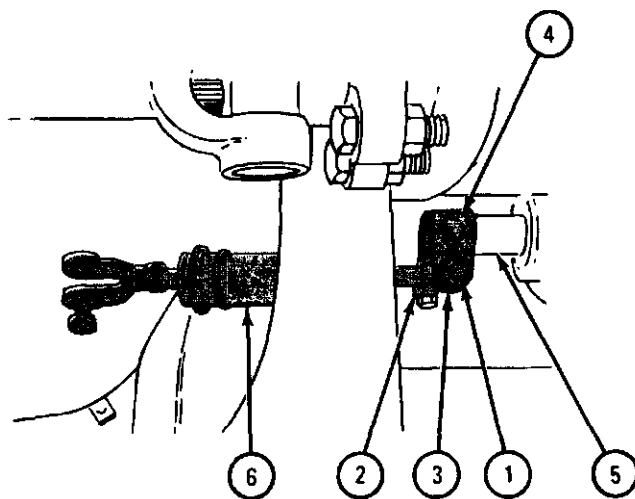

TA 047347

FRAME 3

1. Using 3/4-inch wrench, unscrew and take off locknut (1) and flat washer (2).
2. Using 9/16-inch wrenches, unscrew and take off locknut and flat washer (3).
3. Take out bolt (4) and swing reverse shift lever (5) clear of transmission shifter shaft (6) toward rear of truck.
4. Move reverse shift lever (5) to right side of truck to get bottom end off pivot stud.
5. Lift reverse shift lever (5) out through tunnel area.

GO TO FRAME 4

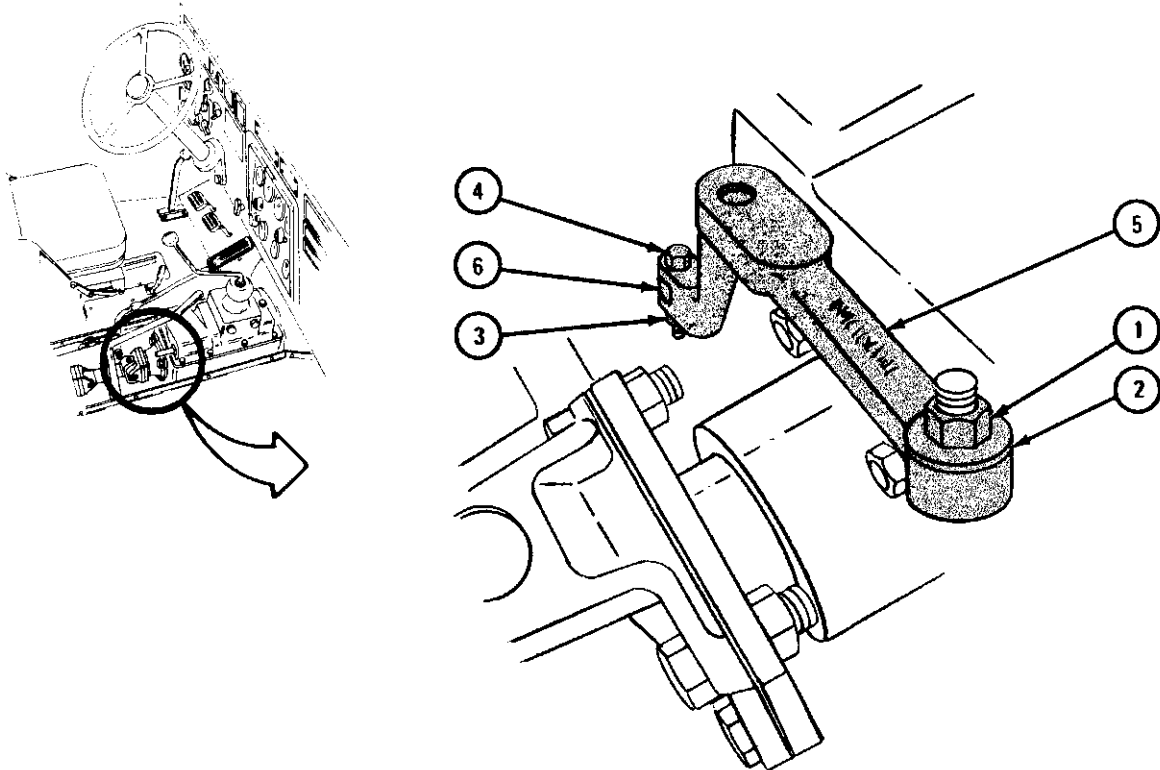

TA 047334

FRAME 4

1. Using 3/4-inch wrenches, unscrew and take off locknut (1). Take out bolt (2) and take shift rod lever (3) away from linkage assembly (4).

END OF TASK

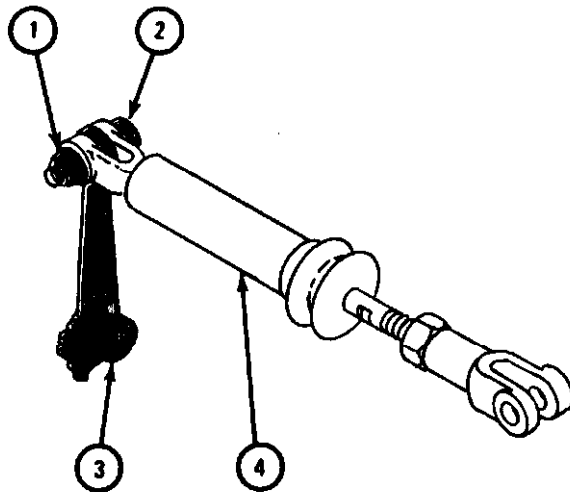

TA 047335

d. Disassembly of Transmission Transfer Reverse Shift Rod (Transmission Transfers Without Air Actuated Positive Lockup).

FRAME 1

1. Using 7/16-inch wrench on flat of reverse shift rod (1), loosen locknut (2), using 3/4-inch wrench.
2. Unscrew and take off yoke (3) and locknut (2).
3. Pull rubber boot (4) off end of reverse shift rod (1).

GO TO FRAME 2

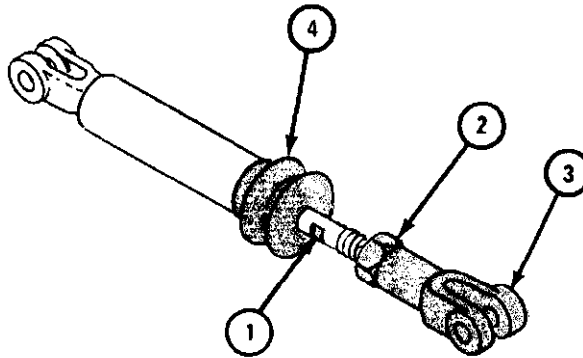

TA 047344

FRAME 2

WARNING

Spring (1) is under pressure. When retaining ring (2) is taken off, let go of reverse shift rod (3) slowly to keep it from flying out and causing injury to personnel.

- Soldier A 1. Put reverse shift rod housing (4) into vise.
2. Place wood block over end of reverse shift rod (3). Press down on rod until spring (1) is compressed below retaining ring (2). Tell soldier B when spring is compressed.
- Soldier B 3. When soldier A has spring (1) compressed, using retaining ring pliers, take off retaining ring (2). Tell soldier A when retaining ring is off.
- Soldier A 4. When retaining ring (2) is off, slowly ease up on wood block until pressure is off; then take wood block away.

WARNING

Spring (1) is under pressure. Hold spring compressed in vise when taking off locknut (6) to keep personnel from being injured.

5. Pull out reverse shift rod (3), spring (1), two flat washers (5), and locknut (6) from reverse shift rod housing (4). Take housing from vise and put spring into vise.
- Soldier B 6. Using 3/8-inch wrench, hold reverse shift rod (3).
- Soldier A 7. Using 9/16-inch wrench, unscrew and take off locknut (6). Take off spring (1) and two flat washers (5).

END OF TASK

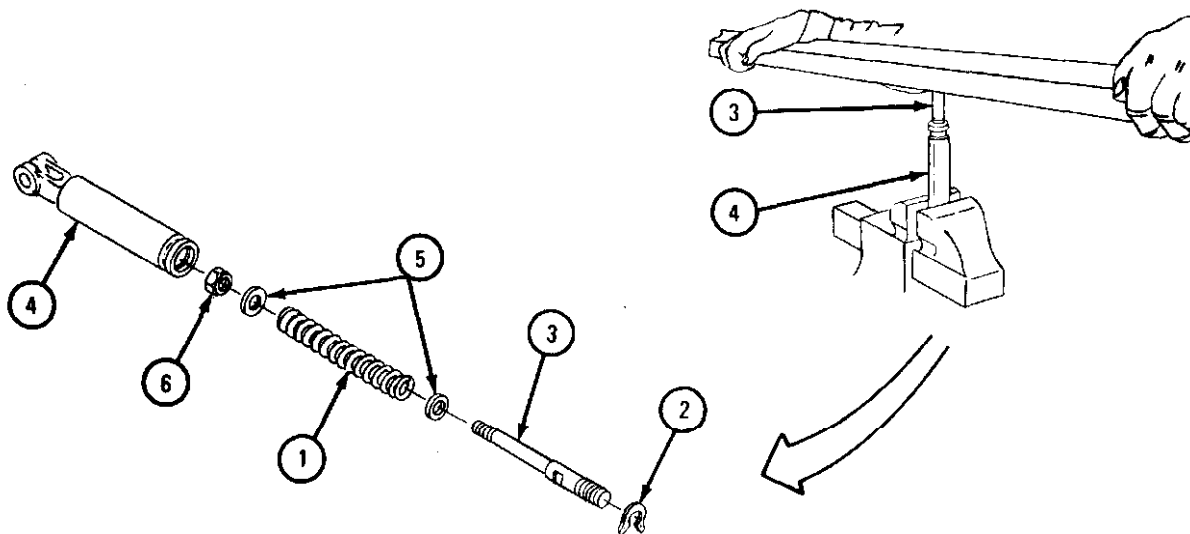

TA 047361

e. Assembly of Transmission Transfer Reverse Shift Rod (Transmission Transfers Without Air Actuated Positive Lockup).

FRAME 1

WARNING

When compressing spring (1) on reverse shift rod (2), use vise or clamp to hold spring compressed. Be careful spring does not slip out of vise or clamp, causing injury to personnel.

NOTE

Clean parts with solvent before assembly.

- Soldier A
1. Put one flat washer (3) on reverse shift rod (2).
 2. Put spring (1) on reverse shift rod (2) and compress spring enough to put on another flat washer (3).
 3. Screw locknut (4) on end of reverse shift rod (2). Hold reverse shift rod with 3/8-inch wrench while tightening locknut, using 3/4-inch wrench.
 4. Put reverse shift rod housing (5) into vise. Put reverse shift rod (2) into housing.

WARNING

When compressing spring (1) with wood block on reverse shift rod (2), care must be taken not to let reverse shift rod slip from wood block, causing injury to personnel.

5. Put wood block on end of reverse shift rod (2) and slowly press down reverse shift rod until spring (1) is compressed inside reverse shift rod housing (5). Tell soldier B when spring is in place.
- Soldier B
6. When spring (1) is in place, using retaining ring pliers, put retaining ring (6) into groove inside reverse shift rod housing (5).
- Soldier A
7. Take away wood block and take reverse shift rod housing (5) from vise.

GO TO FRAME 2

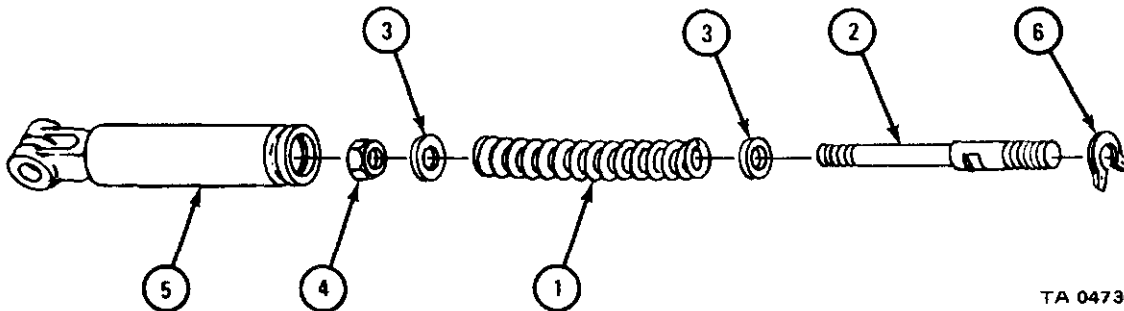

TA 047362

FRAME 2

1. Slip rubber boot (1) over end of reverse shift rod (2) and slide down to reverse housing (3). Put rubber boot over end of reverse housing.
2. While holding reverse shift rod (2) with 7/16-inch wrench, screw on locknut (4) using 3/4-inch wrench.

NOTE

Locknut (4) will be tightened after transmission transfer reverse shift rod assembly is put back on truck.

3. Screw yoke (5) onto reverse shift rod (2).

END OF TASK

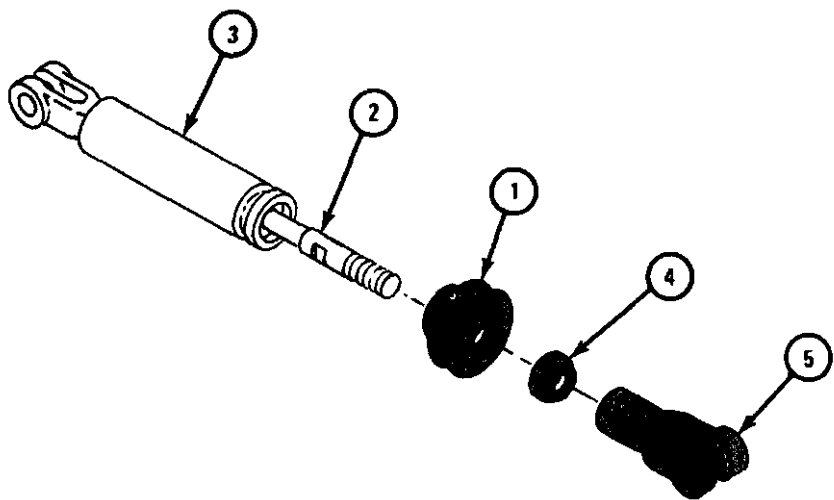

TA 047363

f. Repair of Transmission Transfer Controls and Linkage. Repair transmission transfer controls and linkage by welding, straightening, or replacing bent or damaged parts.

g. Replacement of Transmission Transfer Shift Lever and Linkage.

FRAME 1

1. Screw nut (1) on rod (2) and screw yoke (3) on rod. Do not tighten nut (1) at this time. It will be tightened after assembly is put back on truck.

GO TO FRAME 2

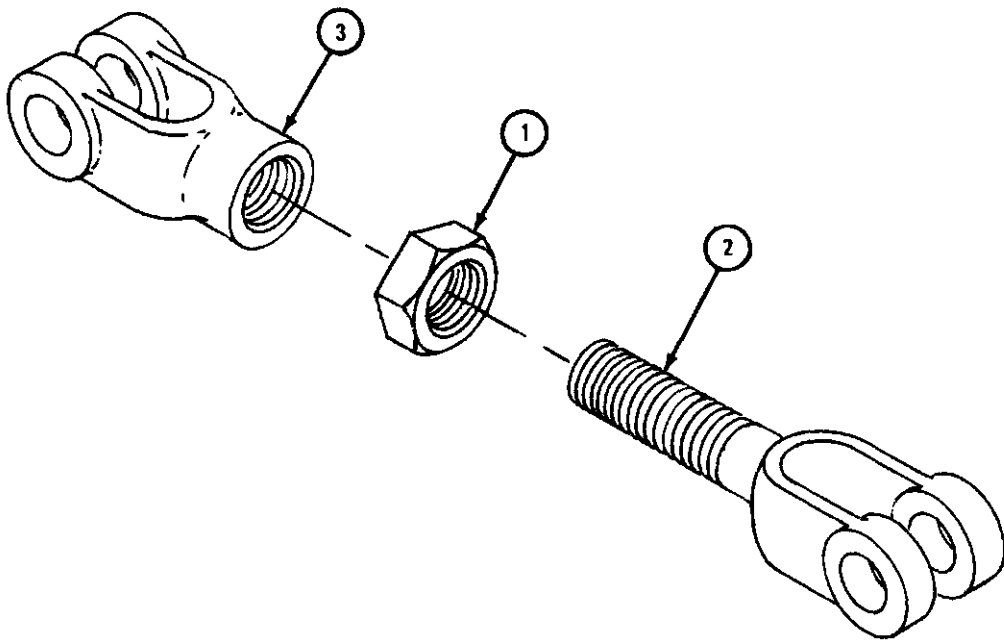

TA 047336

FRAME 2

1. Put shifting lever (1) in yoke of bracket (2) as shown.
 2. Put bolt (3) through yoke of bracket (2) and through lower hole in shifting lever (1).
 3. Using 3/4-inch wrenches, screw on and tighten locknut (4) on bolt (3).
- GO TO FRAME 3

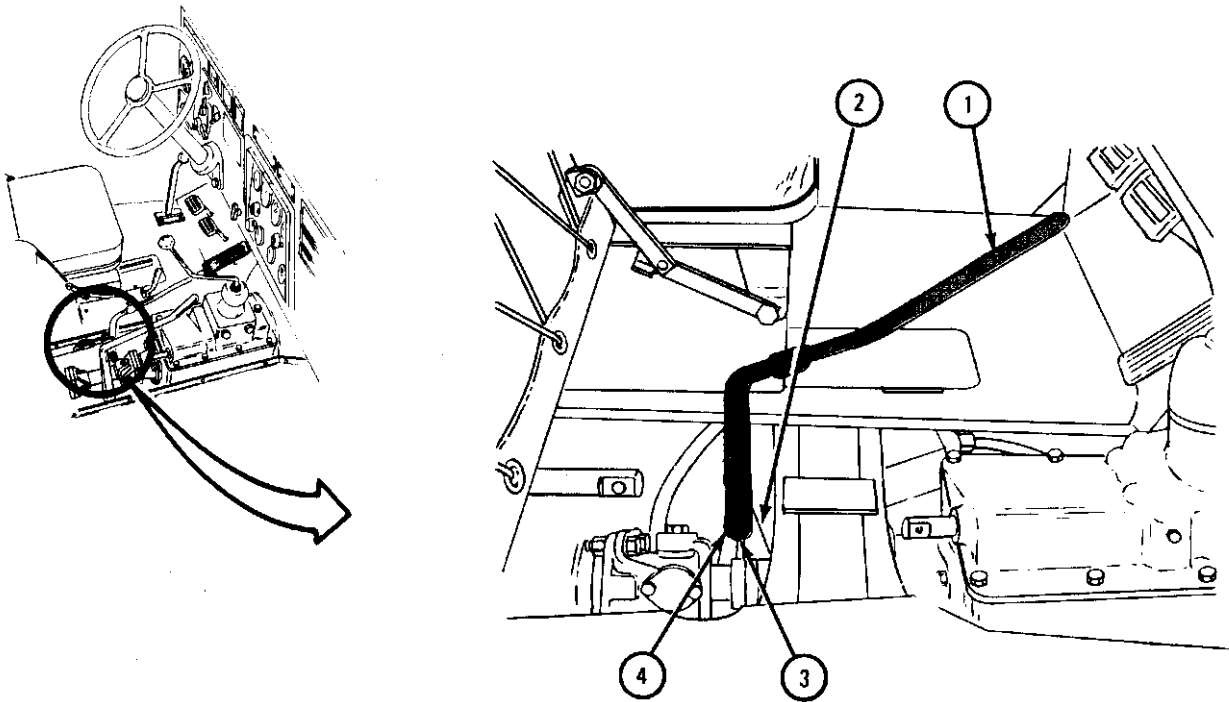

TA 047337

FRAME 3

1. Place shifter link (1) so holes in rod end (2) aline with top hole in shifting lever (3).
2. Put bolt (4) through rod end (2) and shifting lever (3) and screw on locknut (5).
3. Using 3/4-inch wrenches, tighten locknut (5).

GO TO FRAME 4

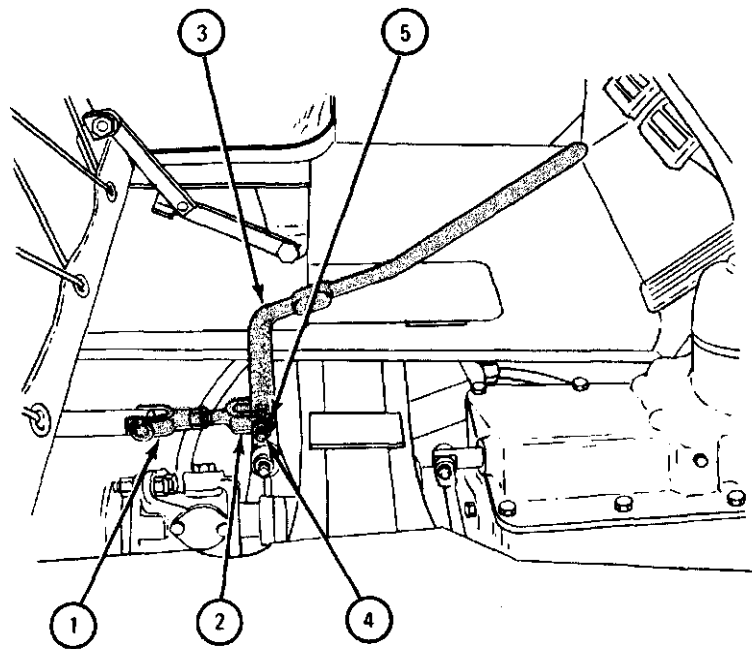

TA 047338

FRAME 4

1. Place rear tunnel (1) over shifting lever (2) and aline tunnel mounting holes with floor holes.
2. Set transfer shifting lever (2) to LOW position with 1/4 to 1/2-inch clearance from floor. This distance is measured at point (A) as shown.
3. Using ruler, measure distance from top of transfer shifting lever (2) to top of crossbrace (3) as shown.
4. Take rear tunnel (1) out of cab.
5. Using ruler, set transfer shifting lever (2) to same distance from crossbrace (3) as it was in step 3.

GO TO FRAME 5

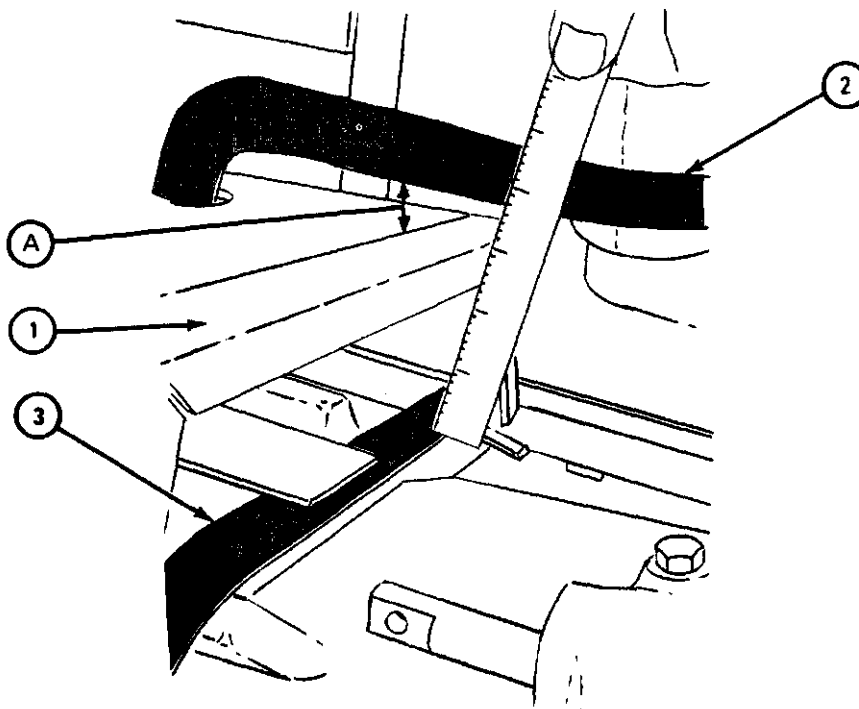

TA 047339

FRAME 5

NOTE

Be very careful not to move shifting lever (1) from the position set in frame 4.

1. Pull shifter shaft (2) out to engage low speed gears. Check that detent action holds it in out position.
2. Check if holes in yoke (3) aline with hole in shifter shaft (2).
3. If holes do not aline, screw yoke (3) onto rod (4) to shorten assembly or unscrew yoke (3) from rod (4) to make assembly longer.
4. When holes in yoke (3) aline with hole in shifter shaft (2), put in bolt (5).

GO TO FRAME 6

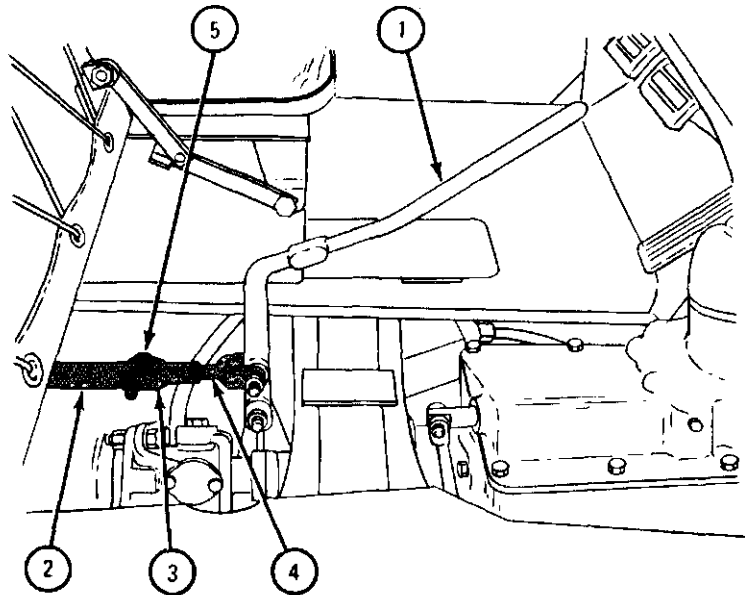

TA 047340

FRAME 6

1. Using 3/4-inch wrenches, screw on and tighten locknut (1) on bolt (2).
2. Using vise grips to hold yoke (3), tighten nut (4), using 3/4-inch wrench.
3. Move transfer shifting lever (5) to NEUTRAL, HIGH, and LOW positions and feel for detent action. Detent in transfer case should hold shifting lever in each of the three positions.

END OF TASK

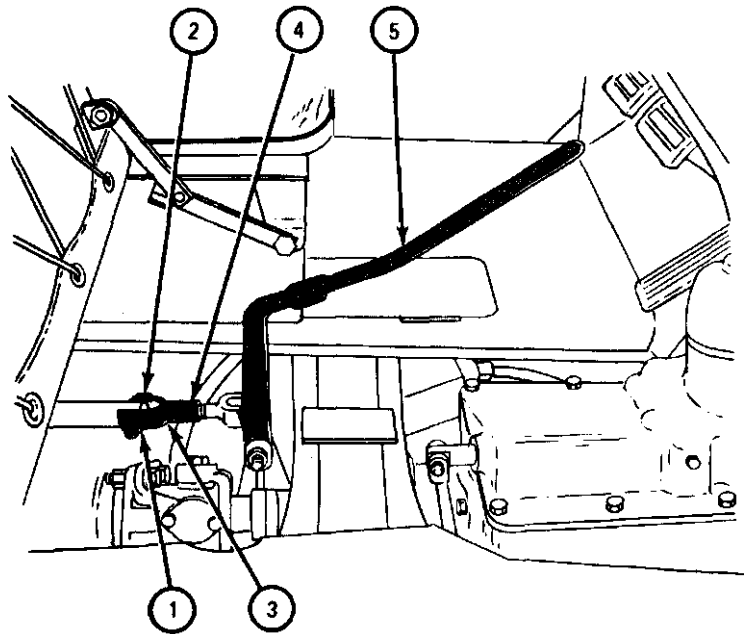

TA 047341

h. Replacement of Transmission Transfer Reverse Shift Levers and Linkage
(Transmission Transfers Without Air Actuated Positive Lockup).

FRAME 1

1. Put shift rod lever (1) in clevis (2) and aline holes.
2. Put bolt (3) through clevis (2) and shift rod lever (1) and screw on locknut (4). Using 3/4-inch wrenches, tighten locknut.

GO TO FRAME 2

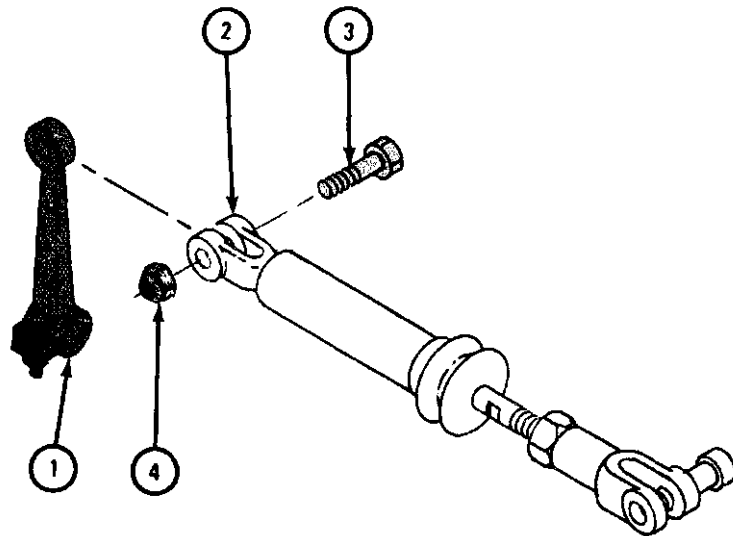

TA 047342

FRAME 2

1. Put lower end of reverse shift lever (1) on pivot stud (2) as shown. Put flat washer (3) on pivot stud and using 3/4-inch wrench, screw on locknut (4).
2. Aline holes in clevis (5) with hole in transmission shifter shaft (6). Put bolt (7) through clevis and transmission shifter shaft.
3. Using 9/16-inch wrenches, screw on and tighten nut and lockwasher (8) On bolt (7).

GO TO FRAME 3

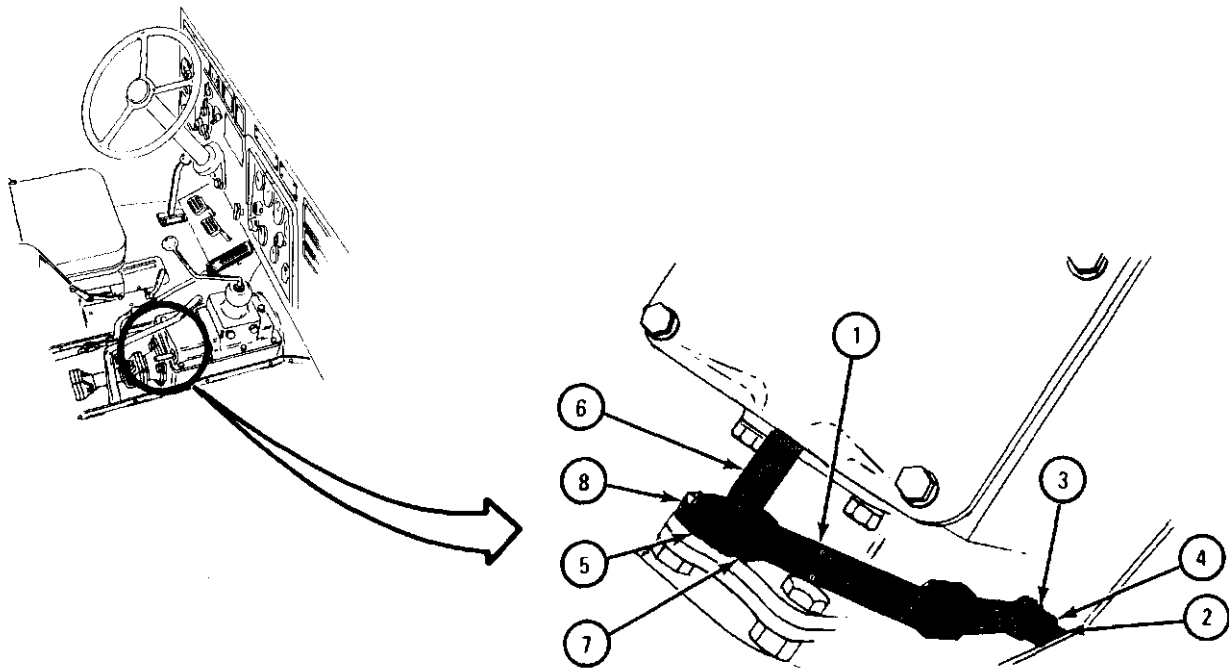

TA 047343

FRAME 3

- Soldier A 1. Working under truck, put transfer reverse shift lever linkage assembly (1) in place over crossmember (2).
2. Using rolling head prybar, push transfer reverse shift rod shaft (3) into transfer (4) to make clearance for transfer reverse shift rod lever (5). Tell soldier B when ready.
- Soldier B 3. Working in cab, when soldier A is ready, slide transfer reverse shift rod lever (5) onto transfer reverse shift rod shaft (3) and aline bolt holes.
- Soldier A 4. Using 9/16-inch socket wrench with 8-inch extension, screw in and tighten bolt (6).
- Soldier B 5. Using 3/4-inch socket wrench, hold bolt (7). Tell soldier A when ready.
- Soldier A 6. When soldier B is ready, using 3/4-inch socket wrench, tighten locknut (8).

GO TO FRAME 4

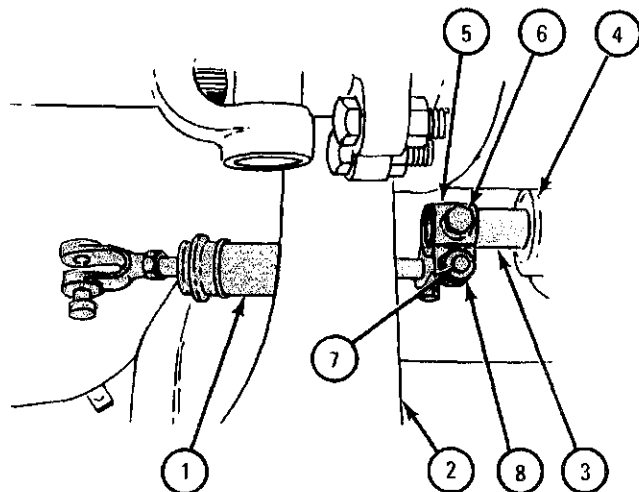
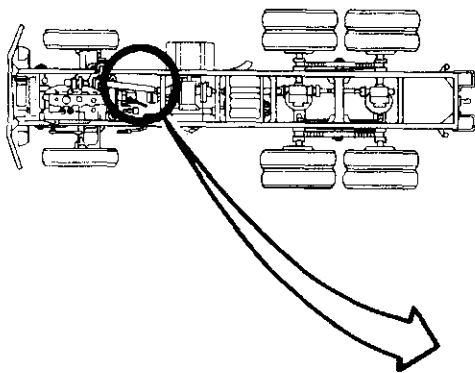

TA 047345

FRAME 4

NOTE

To aline grooved pin (1) in clevis (2) with hole in reverse shaft lever (3), move shift rod lever (4) forward or backward as necessary.

1. Aline grooved pin (1) with hole in reverse shift lever (3).
2. Using small hammer, tap head of grooved pin (1) until seated in clevis (2).

NOTE

Follow-on Maintenance Action Required:

1. Do reverse shift linkage check, and if required, do adjustment procedure. Refer to para 9-5 for check. Refer to para 9-6 for adjustment.
2. Lower front wheel and remove jack. Refer to para 11-4.
3. Replace rear and intermediate tunnels. Refer to Part 3, para 18-5.

END OF TASK

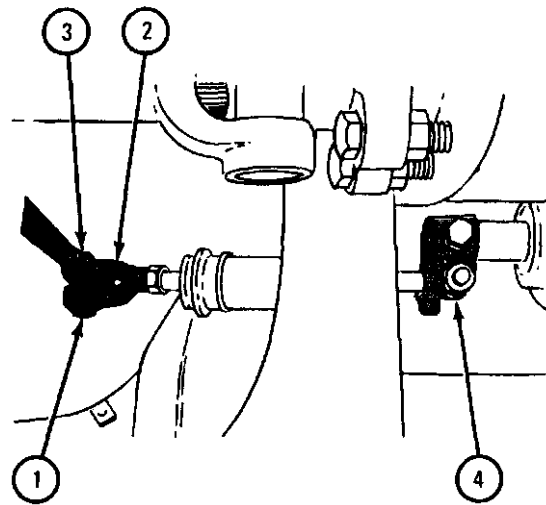

TA 047346

9-5. TRANSMISSION TRANSFER REVERSE SHIFT LINKAGE CHECK.

TOOLS: Jack
Wood blocks

SUPPLIES: None

PERSONNEL: Two

EQUIPMENT CONDITION: Truck parked, engine off, handbrake set, rear wheels chocked.

NOTE

Transfer case must be warmed up to operating temperature before making checks or adjustments on linkage.

Preliminary Procedure. Using jack, raise one front wheel off ground. Refer to para 11-4.

b. Transmission Transfer Reverse Shift Linkage Check.

FRAME 1

- Soldier A 1. Put FRONT TRANSMISSION shift lever (1) in R (reverse gear).
 Soldier B 2. Turn front wheel (2) backwards and then try to turn it forward. Wheel should turn backwards but not forward.
 Soldier A 3. Put FRONT TRANSMISSION shift lever (1) in position 1 (first gear) .
 Soldier B 4. Turn front wheel (2) forward and then try to turn it backwards. Wheel should turn forward but not backwards.
 5. If front wheel (2) turns forward in step 2 or backwards in step 4, do adjustment procedure, para 9-6.

NOTE

Follow-on Maintenance Action Required:

1. Lower front wheel to ground and remove jack. Refer to para 11-4.
2. Take away wood blocks from rear wheels.

END OF TASK

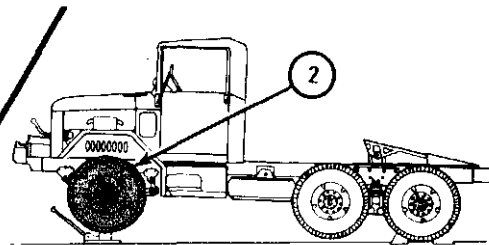
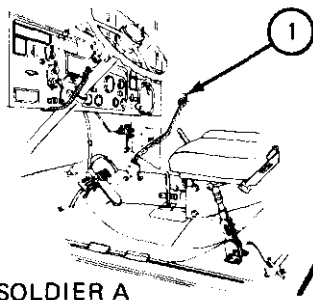

TA 047352

9-6. TRANSMISSION TRANSFER REVERSE SHIFT LINKAGE ADJUSTMENT.

TOOLS: 3/4-inch open end wrench Wood blocks (4)
Large screwdriver 7/16-inch wrench
Jack

SUPPLIES: None

PERSONNEL: Two

EQUIPMENT CONDITION: Truck parked, engine off, handbrake set, rear wheels chocked.

NOTE

Transmission transfer case must be warmed up to operating temperature before making checks or adjustments on linkage.

a. Preliminary Procedure. Using jack, raise one front wheel off ground. Refer to para 11-4.

b. Adjustment (Forward Speed).

FRAME 1

Soldier A 1. Put FRONT TRANSMISSION shift lever (1) to position 1 (first gear).

Soldier B 2. Turn raised wheel (2) 1/2 turn forward.

GO TO FRAME 2

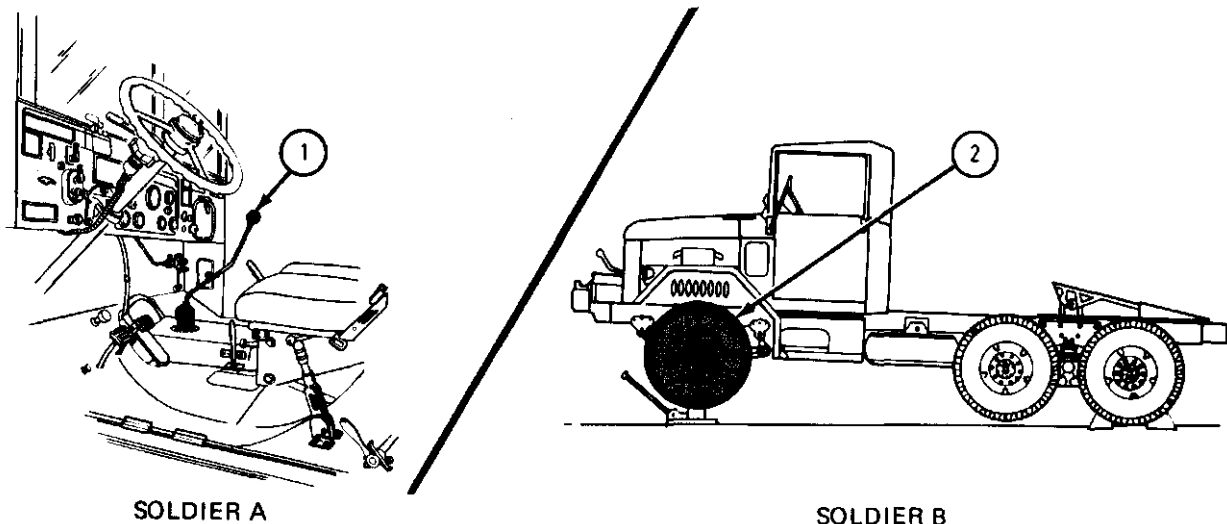

TA 086606

FRAME 2

NOTE

Soldier A stands under truck and watches reverse shift rod lever (1) to see if it moves when soldier B shifts transmission.

- Soldier A 1. While watching reverse shift rod lever (1), tell soldier B to shift transmission into all gears except R (reverse).
- Soldier B 2. Put FRONT TRANSMISSION shift lever (2) in position N (neutral).
- Soldier A 3. If reverse shift rod lever (1) moved, reverse shift rod (3) must be shortened as follows:
- a. Using 3/4-inch wrench, loosen jamnut (4).
 - b. Using 7/16-inch wrench on flat section of reverse shift rod (3), screw rod into yoke (5).
 - c. Using 3/4-inch wrench, tighten jamnut (4) against yoke (5).
- Soldier B 4. Put FRONT TRANSMISSION shift lever (2) in position 1 (first gear).
5. Do steps 1 through 3 again as needed. Reverse shift rod lever (1) should be almost ready to move when FRONT TRANSMISSION gear shift lever (2) goes into neutral (N) position.

GO TO FRAME 3

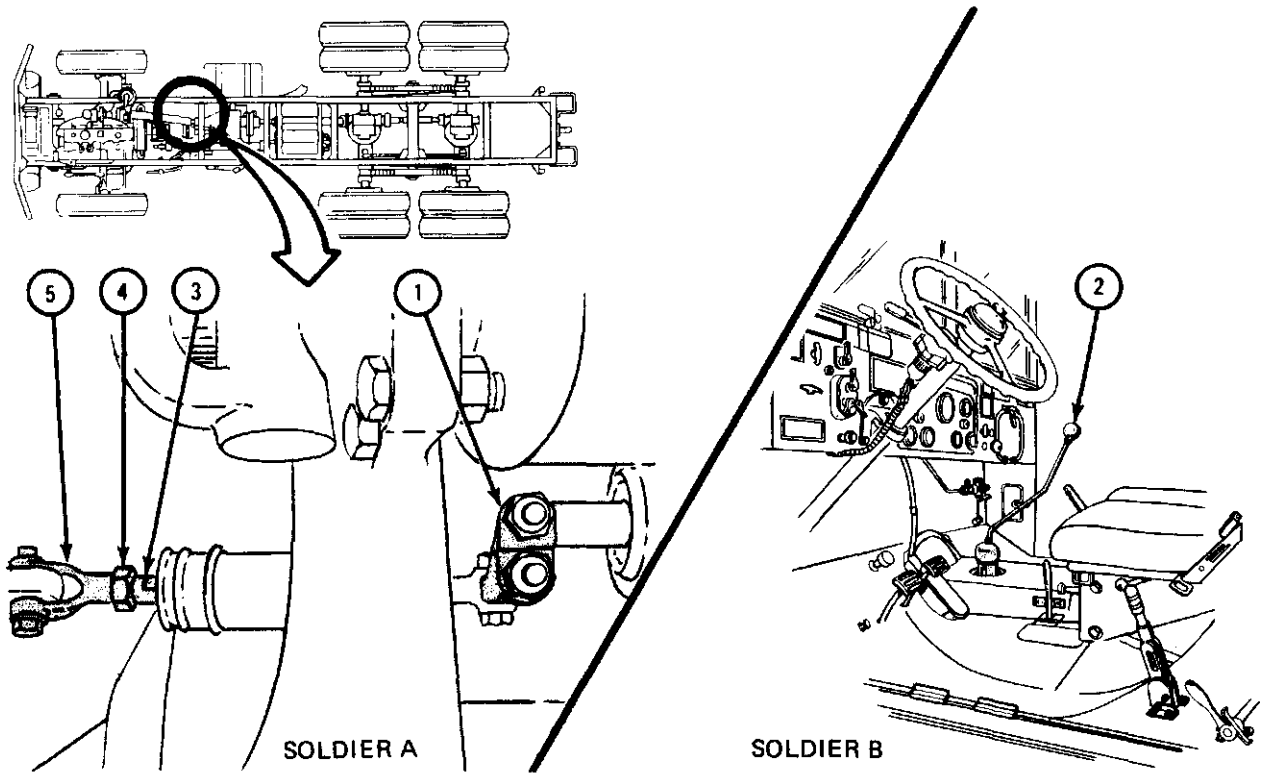

TA 047354

FRAME 3

1. Recheck adjustment with transmission in neutral by trying to pry reverse shift rod lever (1) away from transfer case (2). If lever cannot be moved, forward speed adjustment is complete.
2. If reverse shift rod lever (1) can be moved, repeat forward speed adjustment procedure.

END OF TASK

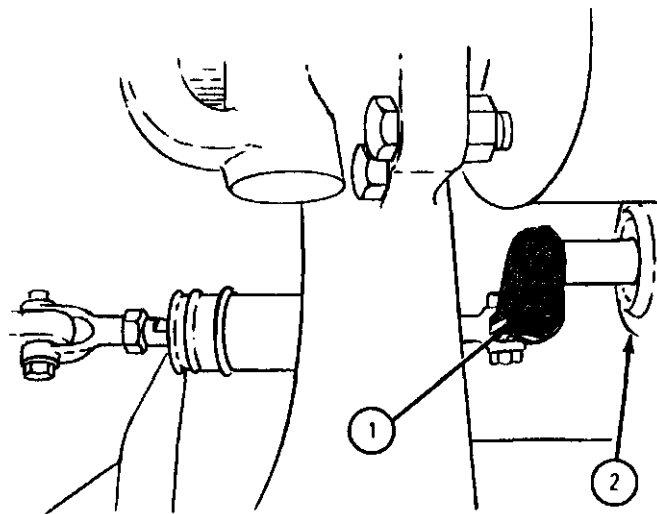

TA 047355

c. Adjustment (Reverse Speed).

FRAME 1

- Soldier A 1. Put FRONT TRANSMISSION shift lever (1) to position R (reverse gear) and standby in cab.
- Soldier B 2. Turn raised wheel (2) 1/2 turn backwards.
- GO TO FRAME 2

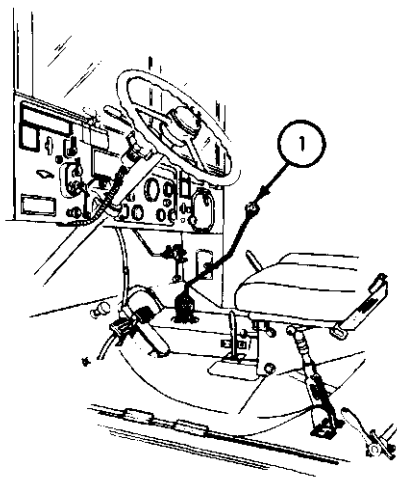

SOLDIER A

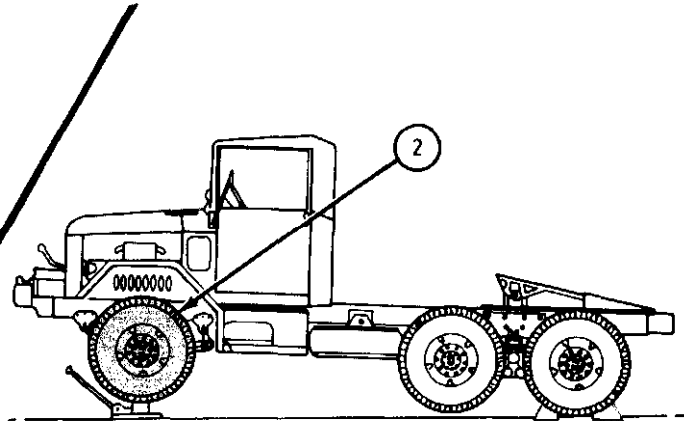

SOLDIER B

TA 086606

FRAME 2

- Soldier A 1. Make sure FRONT TRANSMISSION shift lever (1) stays in position R (reverse gear).
- Soldier B 2. Using screwdriver from under truck, try to pry reverse shift rod lever (1) toward transfer (2). If lever cannot be moved more than 1/16-inch, reverse speed adjustment is complete.
3. If reverse shift rod lever (1) can be moved more than 1/16-inch, lengthen shift rod (3) as follows:
- a. Using 3/4-inch wrench, loosen jamnut (4).
 - b. Using 7/16-inch wrench on flat section of reverse shift rod (3), unscrew rod from yoke (5).
 - c. Using 3/4-inch wrench, tighten jamnut (4) against yoke (5).
4. Do forward speed adjustment procedure again, para 9- 6b and do reverse speed adjustment procedure again. When conditions of step 2 (above) are met, reverse speed adjustment is complete.

NOTE

Follow-on Maintenance Action Required:

1. Do transfer reverse shift linkage check, para 9-5.
2. Lower front wheel to ground and take away jack. Refer to para 11-4.
3. Take wood blocks away from rear wheels.

END OF TASK

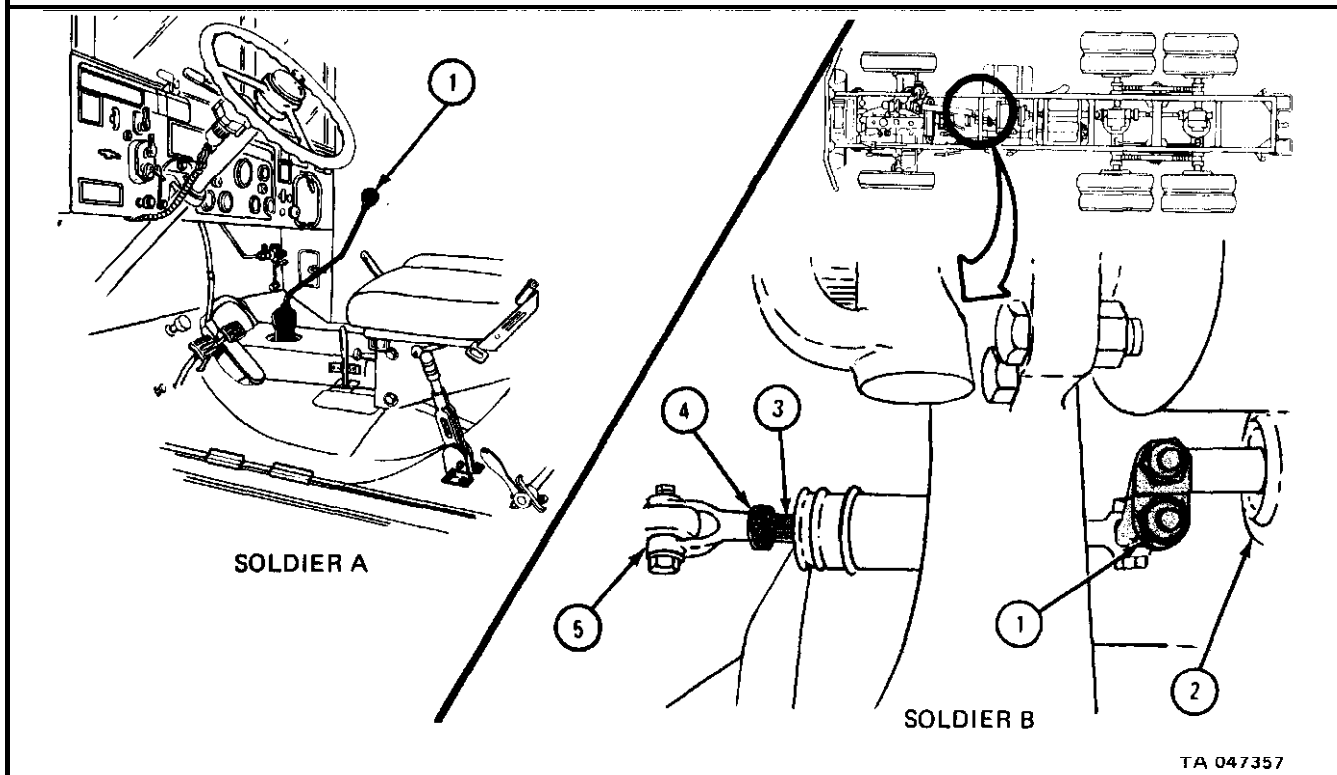

TA 047357

9-7. TRANSMISSION TRANSFER OUTPUT COVER SEAL AND AIR VENT REMOVAL AND REPLACEMENT.

TOOLS: Cross-tip screwdriver (Phillips type)
 9/16-inch wrench
 7/16-inch wrench

SUPPLIES: Seal, transfer output cover
 Solvent, dry cleaning, type II (SD-2) , Fed. Spec P-D-680

PERSONNEL: One

EQUIPMENT CONDITION: Truck parked, engine off, handbrake set.

Preliminary Procedure. Remove intermediate and rear tunnel. Refer to Part 3, para 18-5.

b. Removal.

CAUTION

Cover holds down poppet ball for shifter shaft and will spring up when bolts are loosened. Do not let spring fall into transmission transfer case.

FRAME 1

1. Using 9/16-inch wrench, unscrew four bolts (1) and take off four locknuts (2).
2. Lift off cover (3) and take off seal (4). Throw seal away.
3. Using 7/16-inch wrench, unscrew air vent valve (5) from cover (3).

END OF TASK

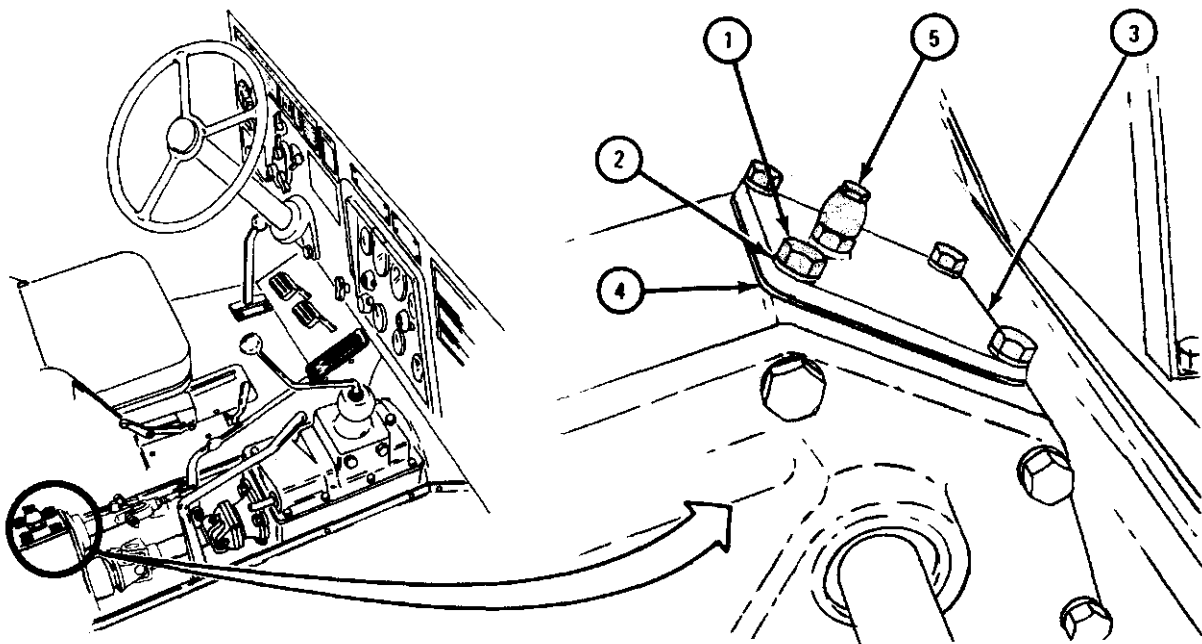

TA 047350

c. Replacement.

FRAME 1

WARNING

Dry cleaning solvent is flammable. Do not use near an open flame. Keep a fire extinguisher nearby when solvent is used. Use only in well-ventilated places. Failure to do this may result in injury to personnel and damage to equipment.

NOTE

Before installing new seal (1), clean mating surface of flange (2) and cover (3) using solvent.

1. Put new seal (1) on transfer output cover flange (2) and aline four holes.
2. Put cover plate (3) over seal (1) and aline four holes.
3. Screw four bolts (4) with lockwashers (5) through cover plate (3) and tighten, using 9/16-inch wrench.
4. Screw air vent valve (6) into cover plate and tighten, using 7/16-inch wrench.

NOTE

Follow-on Maintenance Action Required.

Replace intermediate and rear tunnel. Refer to Part 3, para 18-5.

END OF TASK

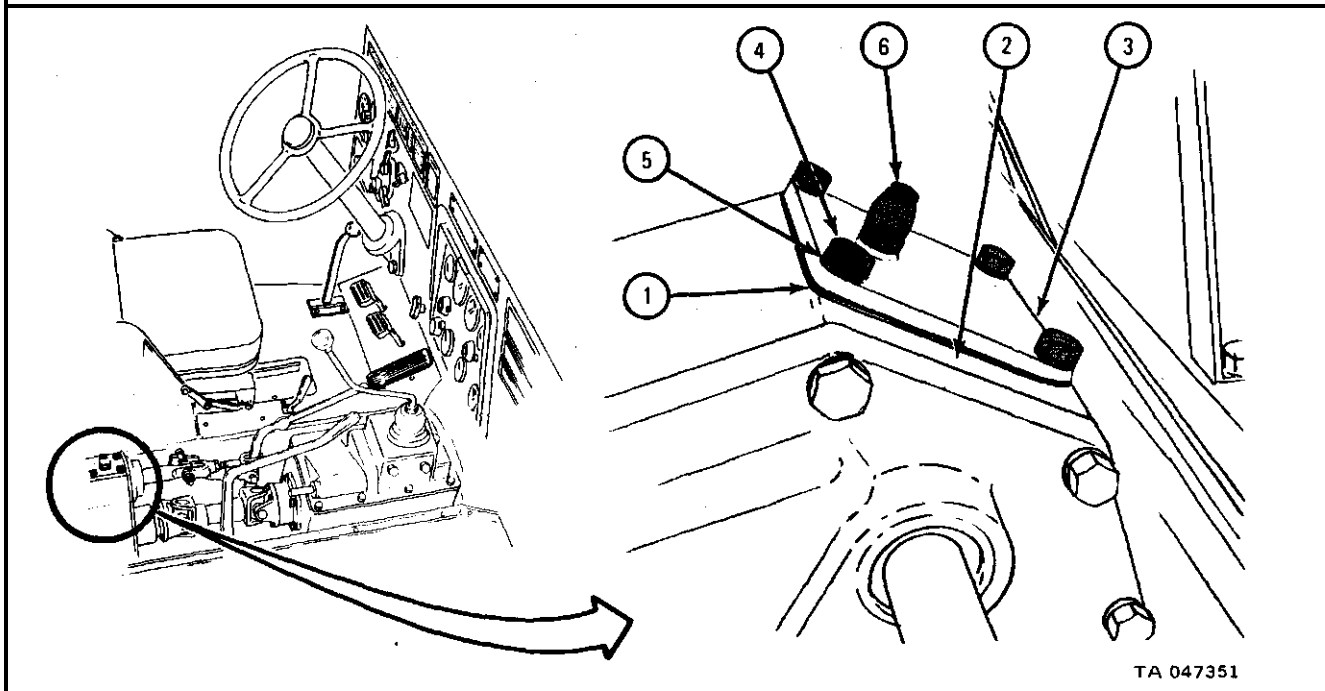

CHAPTER 10

PROPELLER SHAFTS GROUP MAINTENANCE

Section I. SCOPE

10-1. EQUIPMENT ITEMS COVERED. This chapter gives equipment maintenance procedures for propeller shaft assemblies for which there are authorized corrective maintenance tasks at the organizational maintenance level.

10-2. EQUIPMENT ITEMS NOT COVERED. All equipment items for which corrective maintenance is authorized at the organizational maintenance level are covered in this chapter.

Section II. PROPELLER SHAFT ASSEMBLIES

10-3. PROPELLER SHAFT AND UNIVERSAL JOINT (INTERMEDIATE PROPELLER SHAFT) REMOVAL AND REPLACEMENT (TRUCK M36A2).

TOOLS: Socket wrench set, 3/8-inch drive
3/4-inch wrench
7/8-inch wrench
17-inch extension

SUPPLIES: Wheel chocks

PERSONNEL: Two

EQUIPMENT CONDITION: Truck parked, engine off, handbrake set, wheels chocked.



a. Removal.

FRAME 1

1. Using 3/4-inch socket wrench with 17-inch extension, unscrew and take off four locknuts (1).

GO TO FRAME 2

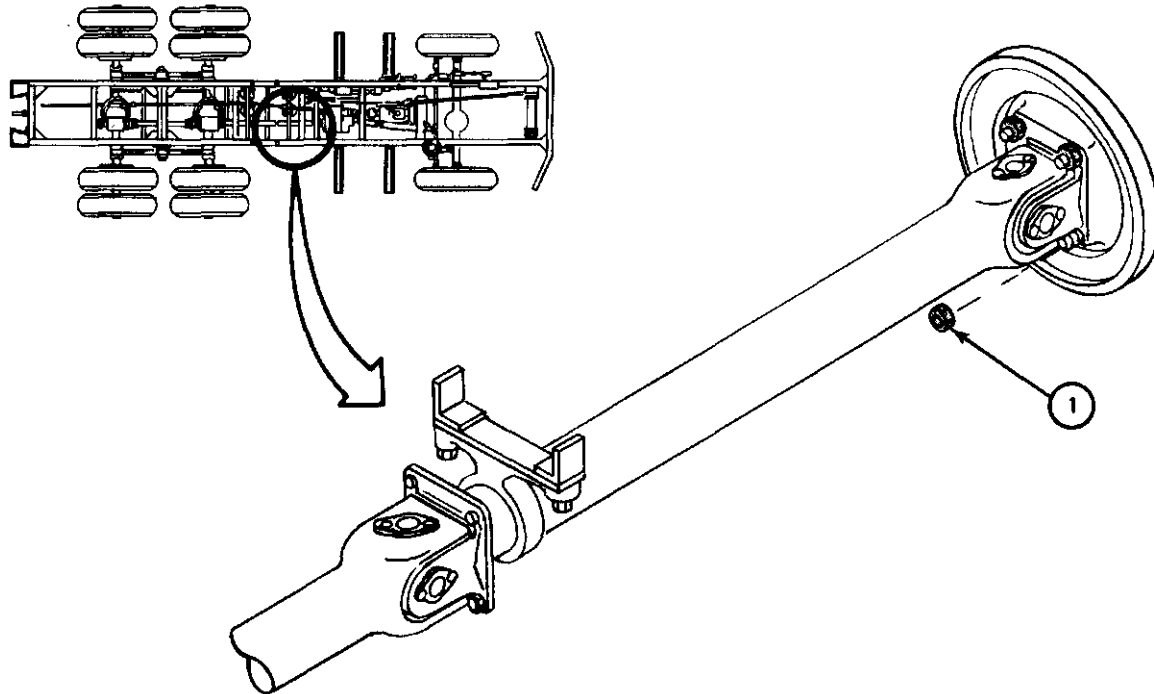

TA 047646

FRAME 2

- Soldier A 1. Hold intermediate propeller shaft (1) while soldier B works on other end of shaft.
2. Using 7/8-inch wrench, hold two shoulder bolts (2).
- Soldier B 3. Using 11/16-inch socket wrench with 5-inch extension and 7/8-inch wrench, unscrew and take off two nuts (3). Then take off two flat washers (4), four rubber bushings (5), and two shoulder bolts (2).

GO TO FRAME 3

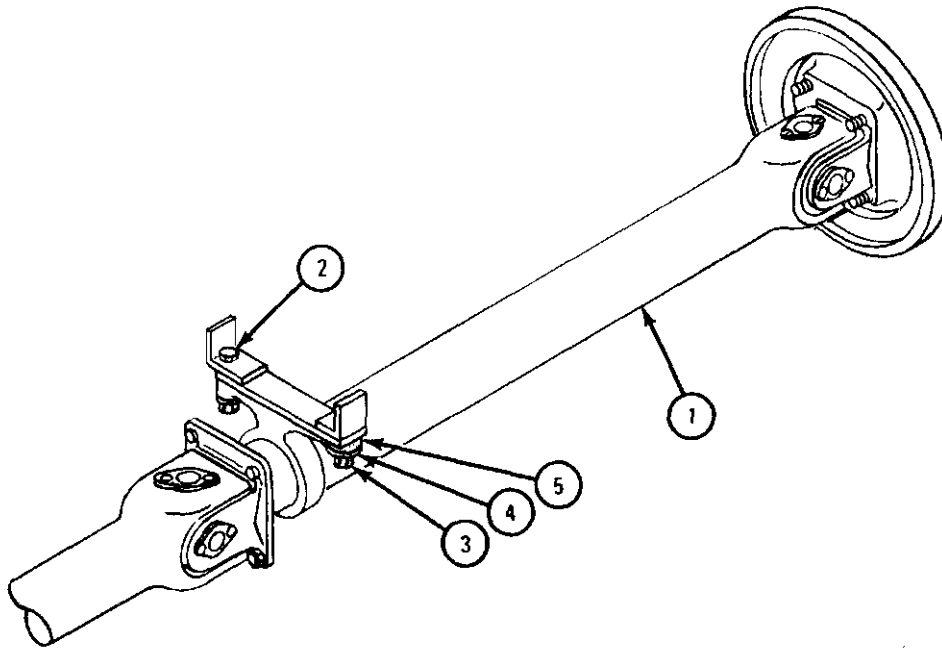

TA 047661

FRAME 3

- Soldier A 1. Hold up intermediate propeller shaft (1).
- Soldier B 2. Using 3/4-inch socket wrench and 3/4-inch wrench, unscrew and take off four locknuts (2) and bolts (3).
3. Carefully set end of forward rear propeller shaft (4) on ground.
- Soldier A 4. Carefully pull intermediate propeller shaft (1) away from studs (5) and set it on ground. Be careful not to strip threads on studs.

END OF TASK

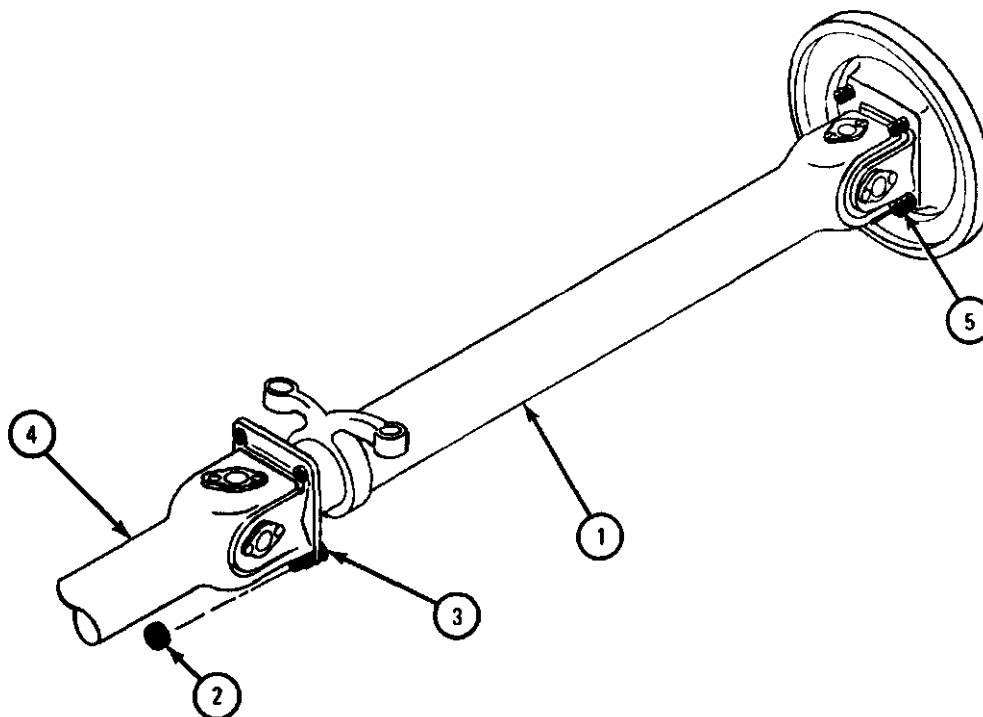

TA 047647

b. Replacement.

FRAME 1

Soldier A 1. Holding intermediate propeller shaft (1) in place under truck, slide flange (2) onto flange studs (3). Be careful not to strip threads on studs.

Soldier B 2. Screw on and hand tighten locknuts (4).

GO TO FRAME 2

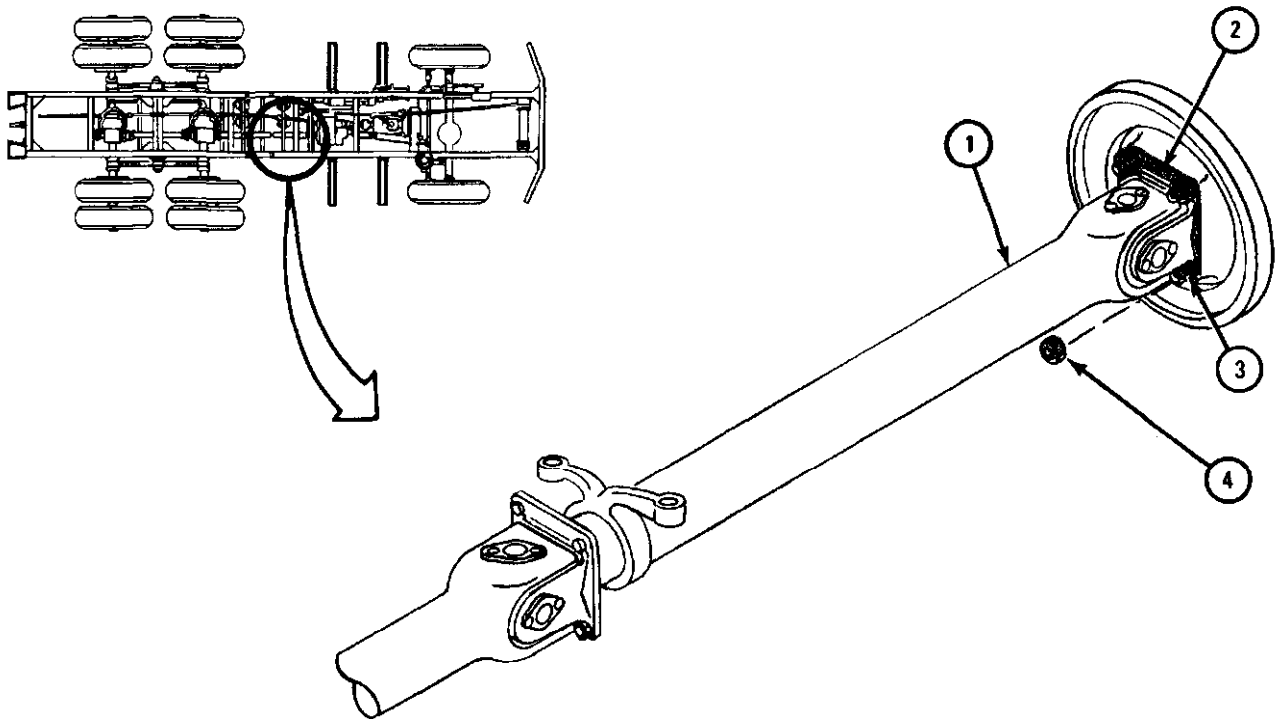

TA 047648

FRAME 2

- Soldier A 1. Hold intermediate propeller shaft (1) in place.
- Soldier B 2. Put four rubber bushings (2) in pillow block housing (3).
3. Line up holes in pillow block housing (3) with holes in frame (4).
4. Put bolt (5) through each hole in frame (4).
5. Put flat washer (6) on each bolt (5) and screw on and hand tighten nut (7).

GO TO FRAME 3

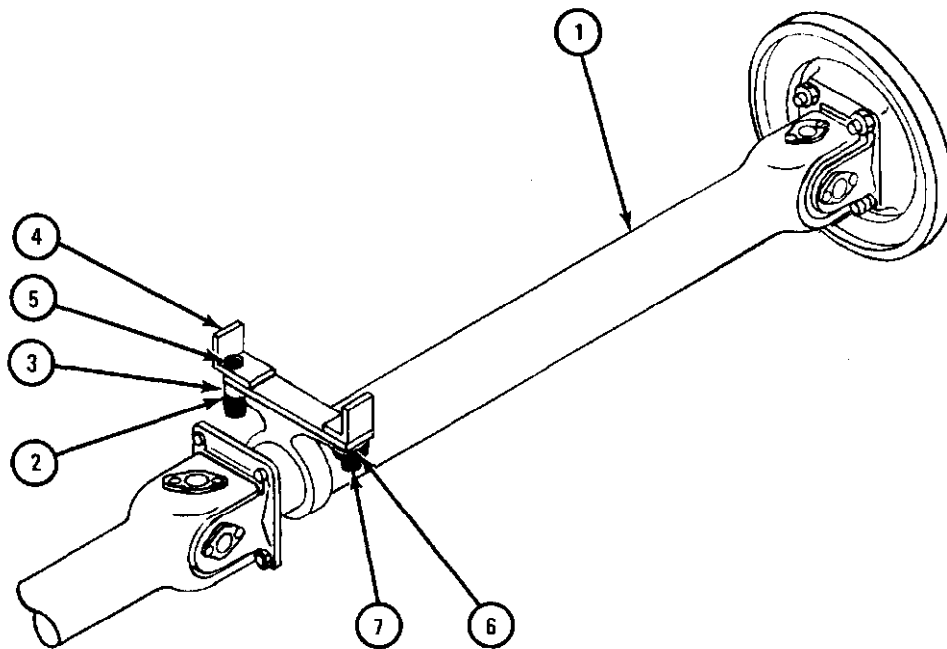

TA 047649

FRAME 3

Soldier A 1. Push handbrake (1) forward.

CAUTION

Be careful not to hit grease fitting (2) when putting in propeller shaft (3). A damaged grease fitting will cause improper lubrication.

Soldier B 2. Line up holes in forward rear propeller shaft yoke (3) with holes in intermediate propeller shaft flange (4).

3. Put four bolts (5) through holes in intermediate propeller shaft flange (4).

4. Screw on and hand tighten four locknuts (6) on bolts (5).

GO TO FRAME 4

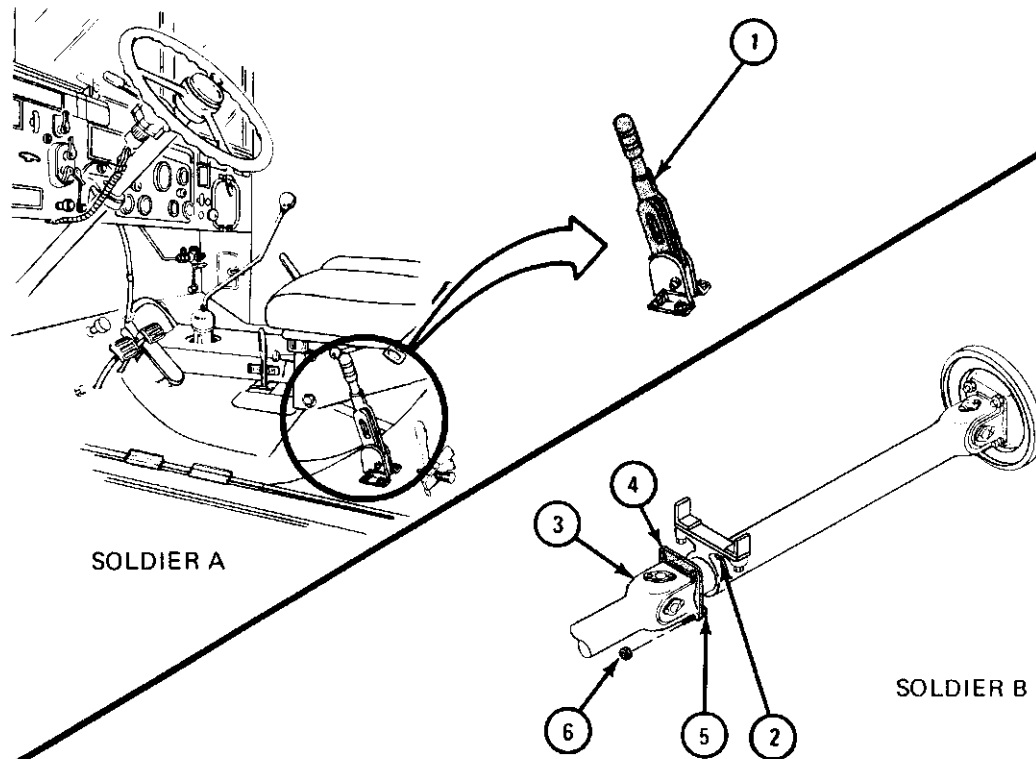

TA 047650

FRAME 4

1. Using 3/4-inch socket wrench with 17-inch extension, tighten four nuts (1).
2. Using 11/16-inch socket wrench with 5-inch extension and 7/8-inch wrench, tighten two nuts (2) and bolts (3).
3. Using 3/4-inch socket wrench and 3/4-inch wrench, tighten four nuts (4) and bolts (5).

END OF TASK

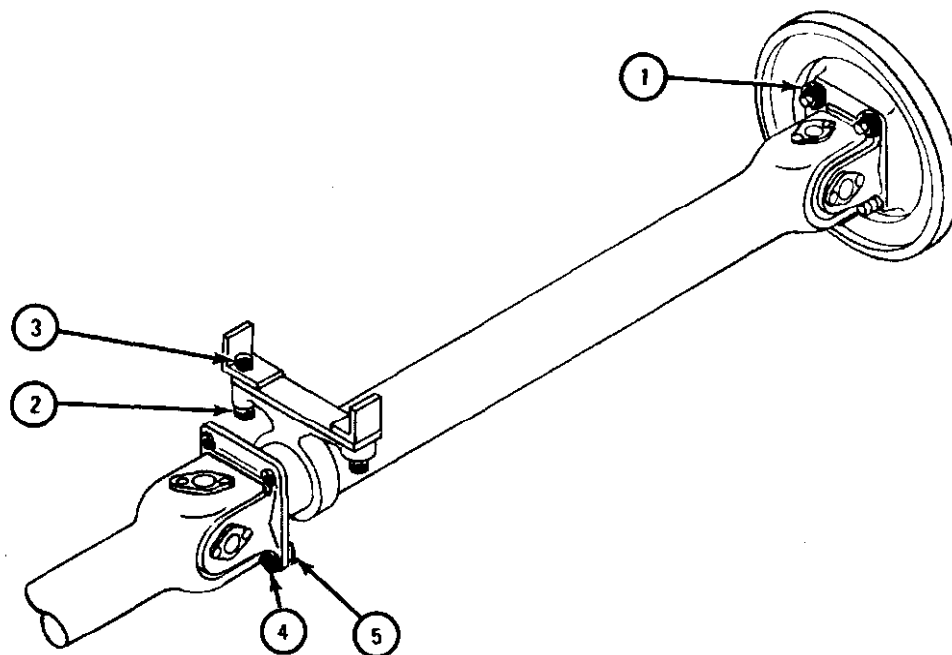

TA 047662

10-4. PROPELLER SHAFT AND UNIVERSAL JOINTS REMOVAL AND REPLACEMENT
(ALL EXCEPT INTERMEDIATE PROPELLER SHAFT ON TRUCK M36A2).

TOOLS: 3/4-inch wrench

SUPPLIES: None

PERSONNEL: One

EQUIPMENT CONDITION: Truck parked, engine off, handbrake set.

a. Removal.

FRAME 1

WARNING

Always jack up one wheel of the axle driven by propeller shaft being removed. This is to keep personnel from being hurt by windup of shaft.

NOTE

Before taking propeller shaft out, make sure arrow (1) stamped on shaft and sleeve yoke at slip joint can be seen. If not, mark both parts so they can be put together in same position.

1. Using wrench, unscrew four nuts (2) and take off nuts and screws (3).
2. Let end of propeller shaft (4) down slowly.
3. Using wrench, unscrew four nuts (5) and take off nuts and screws (6).
4. Take out propeller shaft (4) with universal joints (7).

END OF TASK

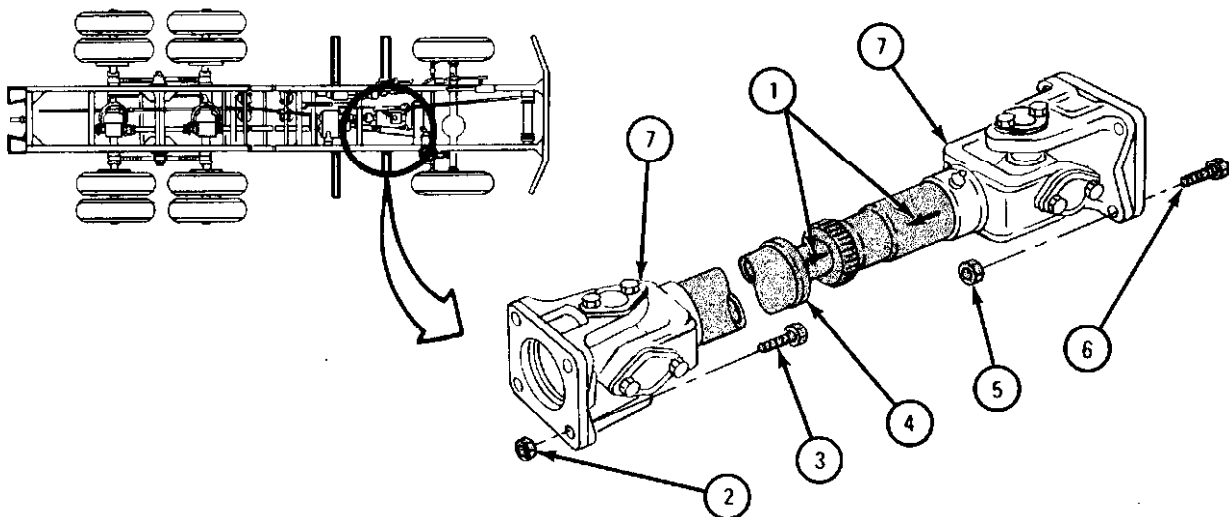

TA 047643

b. Replacement.

FRAME 1

1. Lift one end of propeller shaft (1). Line up holes in universal joint yoke (2) with those in companion flange (3).
2. Put four screws (4) through holes in universal joint yoke (2) and companion flange (3).
3. Screw on and hand tighten nuts (5) on screws (4).

GO TO FRAME 2

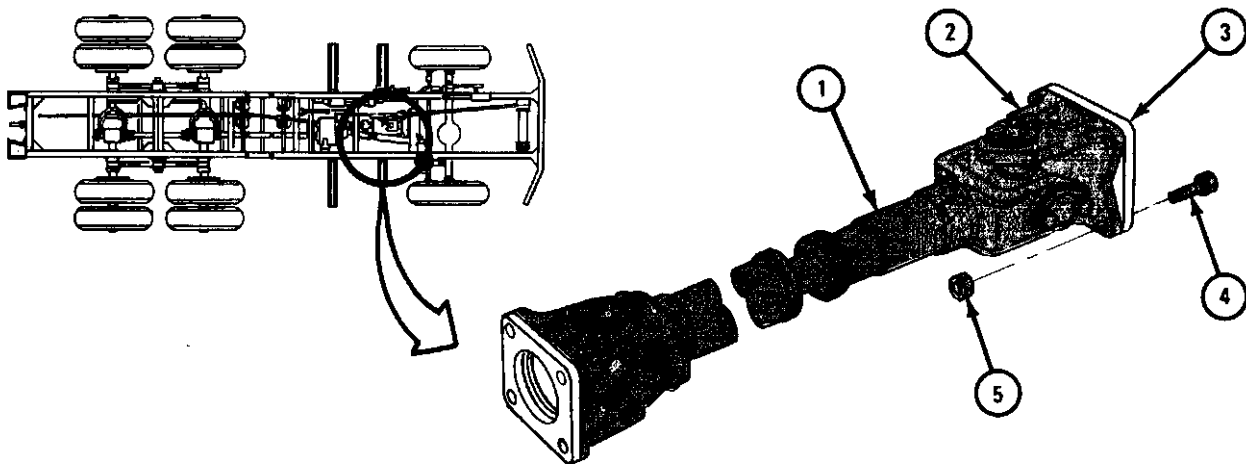

TA 047644

FRAME 2

1. Lift up other end of propeller shaft (1). Line up holes in universal joint yoke (2) with those in companion flange (3).
2. Put four screws (4) through holes in universal joint yoke (2) and companion flange (3).
3. Screw on and hand tighten nuts (5) on screws (4).
4. Using wrench, tighten nuts (5 and 6).

END OF TASK

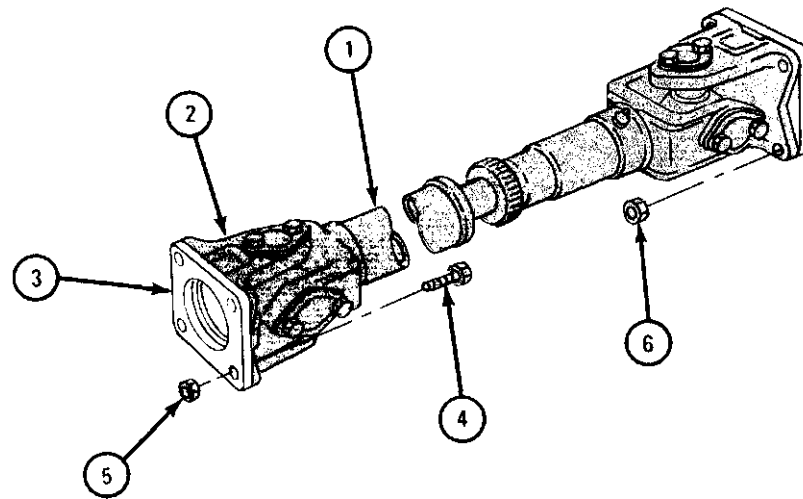

TA 047645

10-5. UNIVERSAL JOINT (SNAPRING, C-RING, AND BEARING CAP TYPE)
REPAIR.

TOOLS: Retaining ring pliers
Machinist hammer, small
5/16-inch wrench
9/16-inch wrench
Flat-tip screwdriver
Drift pin punch
Rawhide mallet
Grease gun
Fine polishing stone
Chisel

SUPPLIES: Universal joint repair kit
Solvent, dry cleaning, type II (SD-2), Fed. Spec P-D-680
Artillery and automotive grease, type GAA, MIL-G-10924
Wood block

PERSONNEL: One

EQUIPMENT CONDITION: Universal joint assembly out of truck.

a. Disassembly (Snapring and C-Ring Type).

NOTE

This procedure is the same for both types
except where noted.

FRAME 1

1. If working on snapring type, using retaining ring pliers, take out four retaining rings (1).
2. If working on C-ring type, using retaining ring pliers, take out two retaining rings (2).
3. Using 5/16-inch wrench, unscrew and take out grease fitting (3).

GO TO FRAME 2

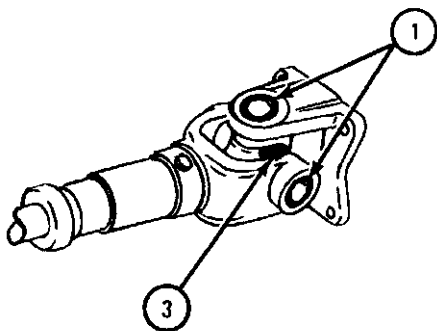

SNAPRING TYPE

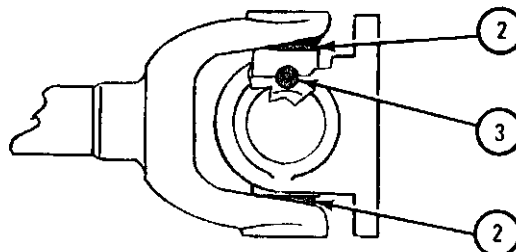

C-RING TYPE

TA 047515

FRAME 2

1. Place one side of yoke (1) on wood block as shown.

NOTE

Diameter of drift pin punch should be just a little smaller than diameter of bearing.

2. Center drift pin punch (2) on face of top bearing (3) as shown. Tape drift pin punch lightly with hammer until bottom bearing (4) is driven out.
3. Turn yoke (1) over and repeat steps 1 and 2 to drive out other bearing.
4. Tilt spider (5) to one side and lift spider out of yoke (1).

GO TO FRAME 3

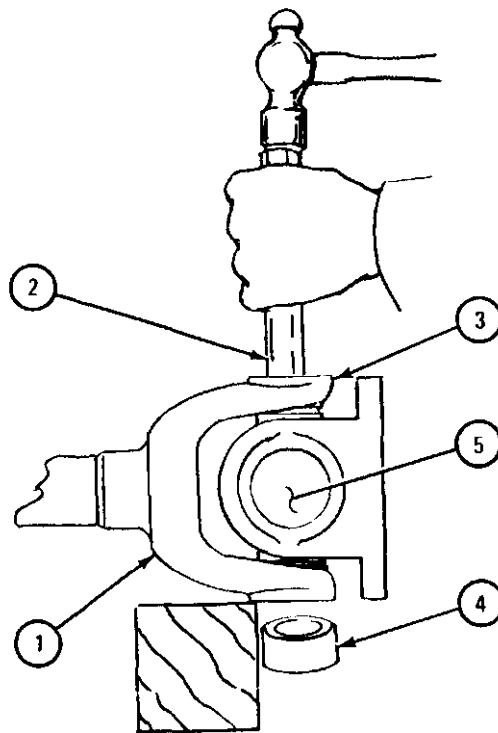

TA 047192

FRAME 3

1. Place yoke (1) on wood block as shown.
2. Center drift pin punch (2) on face of top bearing (3) as shown. Tap drift pin punch lightly with hammer until bottom bearing (4) is driven out.
3. Turn yoke (1) over and do steps 1 and 2 again to drive out other bearing.
4. Tilt spider (5) to one side and lift spider out of yoke (1).
5. Take four gaskets (6) and four retainers (7) off four journals in spider (5).
Throw away gaskets and retainers.

END OF TASK

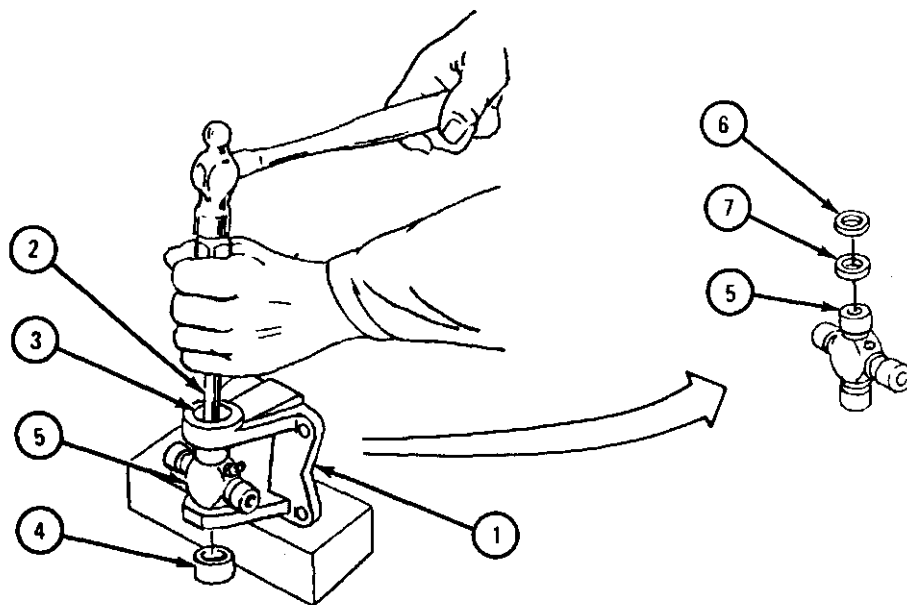

TA 047193

b. Disassembly (Bearing Cap Type).

FRAME 1

1. Using screwdriver, bend down eight lugs (1) on four locking straps (2).
2. Using 9/16-inch wrench, unscrew and take off eight bolts (3).
3. Take off four locking straps (2).

GO TO FRAME 2

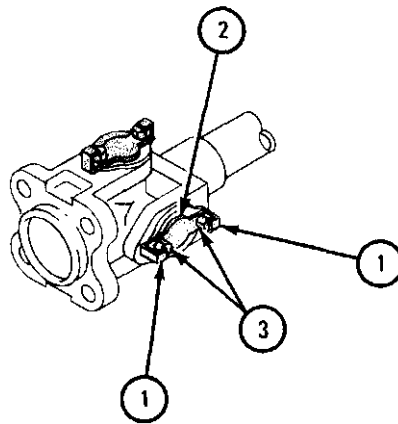

TA 047194

FRAME 2

1. Place one side of yoke (1) on block of wood as shown.

NOTE

When prying off bearing cap (2), cap may break. If bearing cap (2) breaks, take off other bearing cap (3) and go to frame 3.

2. Using hammer and chisel, pry off bearing cap (2).
3. Turn yoke (1) over and do step 2 again to take off other bearing cap (3).
4. Tilt spider (4) to one side and lift spider out of yoke (1).

GO TO FRAME 3

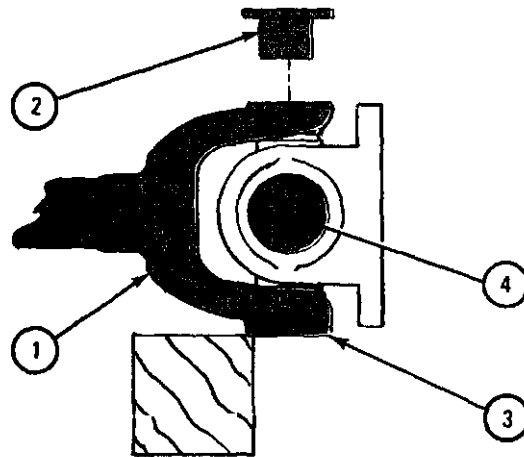

TA 101710

FRAME 3

1. Place one side of yoke (1) on wood block as shown.

NOTE

Diameter of drift pin punch should be just a little smaller than diameter of journal.

2. Center drift pin punch (2) on face of journal (3) as shown. Tap drift pin lightly with hammer until bottom bearing (4) is driven out.
3. Tilt spider (5) to one side and lift spider out of yoke (1).

GO TO FRAME 4

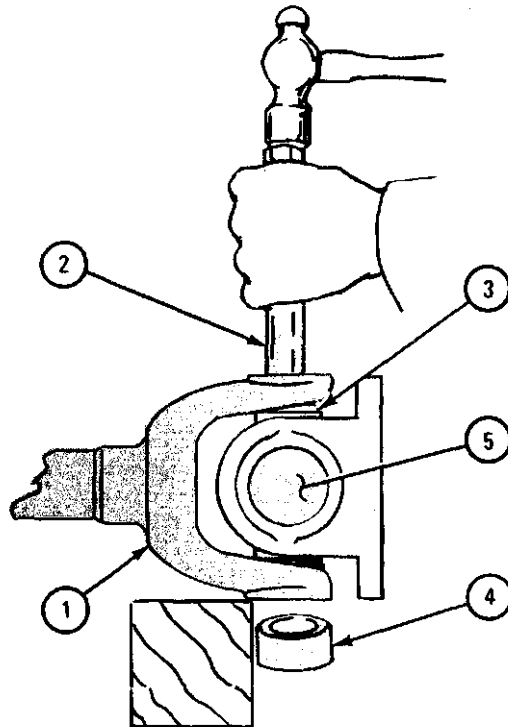

TA 101706

FRAME 4

1. Place yoke (1) on wood block as shown.

NOTE

When prying off bearing cap (2), cap may break. If bearing cap (2) breaks, take off other bearing cap (3) and go to frame 5.

2. Using hammer and chisel, pry off bearing cap (2).
3. Turn yoke (1) over and do step 2 again to take off other bearing cap (3).
4. Tilt spider (4) to one side and lift spider out of yoke (1).
5. Take four gaskets (5) and four retainers (6) off four journals in spider (4).
Throw away gaskets and retainers.

GO TO FRAME 5

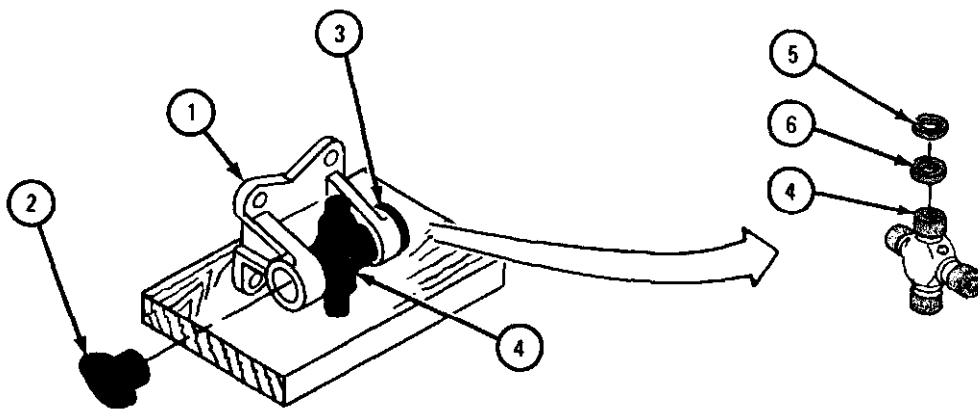

TA 101707

FRAME 5

1. Place yoke (1) on wood block as shown.

NOTE

Diameter of drift pin punch (2) should be just a little smaller than diameter of journal.

2. Center drift pin punch (2) on face of journal (3) as shown. Tap drift pin punch lightly with hammer until bottom bearing (4) is driven out.
3. Tilt spider (5) to one side and lift spider out of yoke (1).
4. Take four gaskets (6) and four retainers (7) off four journals in spider (5). Throw away gaskets and retainers.

END OF TASK

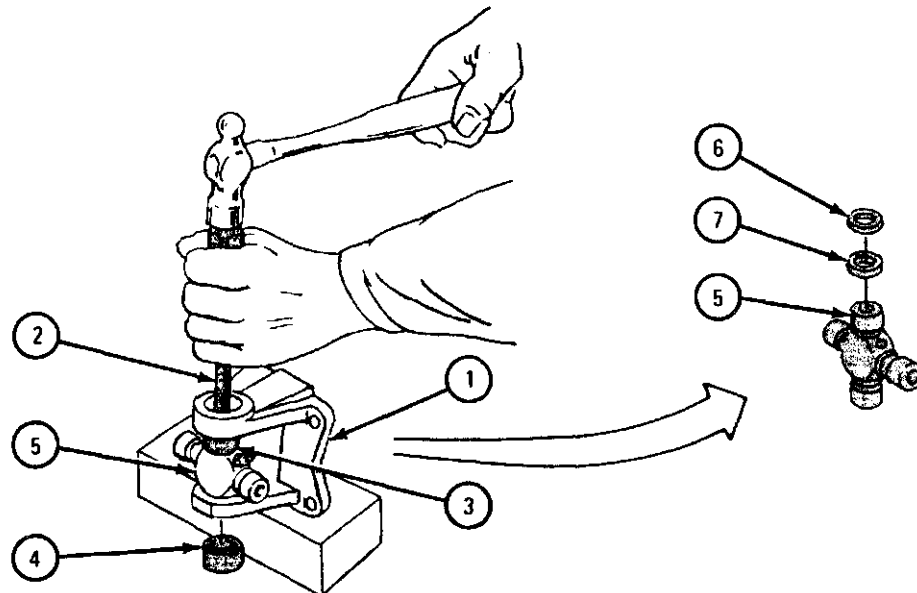

TA 101711

c. Cleaning (All Types).

WARNING

Dry cleaning solvent is flammable. Do not use near an open flame. Keep a fire extinguisher nearby when solvent is used. Use only in well-ventilated places. Failure to do this may result in injury to personnel and damage to equipment.

(1) Using cleaning solvent, clean dirt and grit from all parts. Check to make sure lubrication and relief opening are clear.

(2) If necessary, soak parts in solvent and use stiff brush to clean off caked grease.

d. Inspection and Repair (All Types).

FRAME 1

1. Check yokes (1) for cracks, wear or bent condition. Take off slight nicks or burrs using fine stone.
2. Check journal bearing surfaces (2) for nicks, burrs, and scratches. Use fine stone to take off light marks. Get a new spider (3) if marks cannot be removed.
3. If new spider (3) must be used, get four new bearings (4).
4. Check bearings (4) and bearing caps (5) for wear. If needles drop out of bearings, get new bearings. If journal bearing surfaces (2) show marks of needles, get new spider (3) and bearings.

END OF TASK

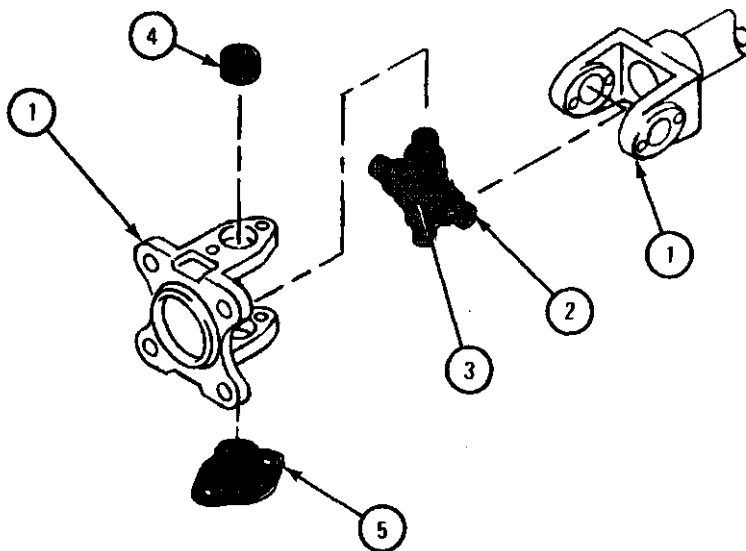

TA 047195

e. Assembly (Snapping and C-Ring Type).

NOTE

This procedure is the same for both types except where noted.

FRAME 1

1. Put four retainers (1) and four gaskets (2) on journals (3).
2. Screw grease fitting (4) into spider (5) and tighten using 5/16-inch wrench.
3. Put spider (5) into flange yoke (6) by tilting spider as necessary.
4. Using fingers, press two bearings (7) over two journals (3) through holes in yoke (6).
5. Place assembly on a wood block as shown. Hold spider (5) in place and tap each bearing (7) into yoke (6) using rawhide mallet.

GO TO FRAME 2

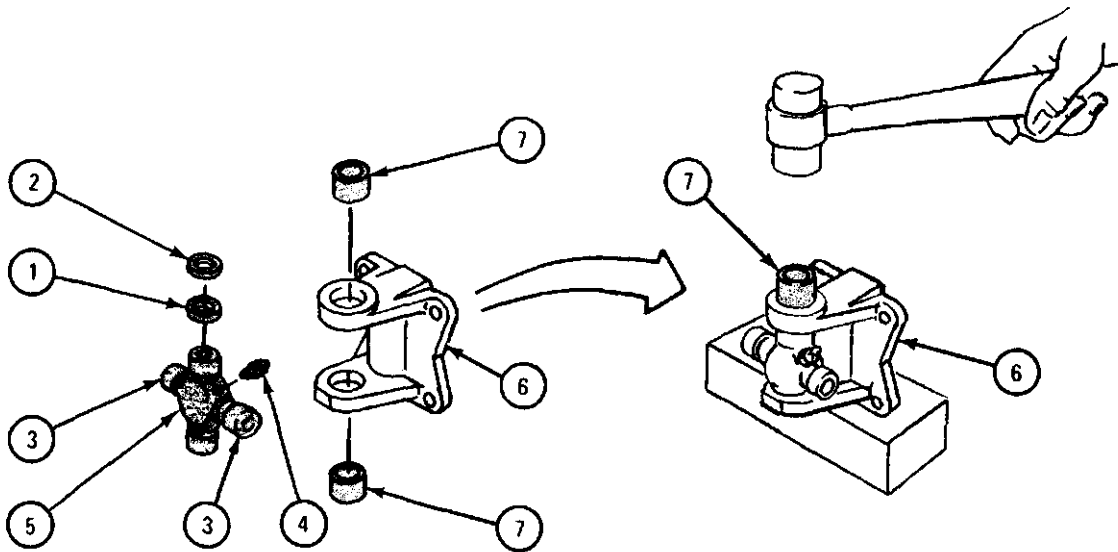

TA 047196

FRAME 2

1. Put journals (1) into holes in shaft yoke (2) as shown by tilting spider (3).
2. Using fingers, press two bearings (4) over ends of journals (1) through holes in shaft yoke (2) as shown.
3. Using rawhide millet, tap each bearing (4) into shaft yoke (2).

GO TO FRAME 3

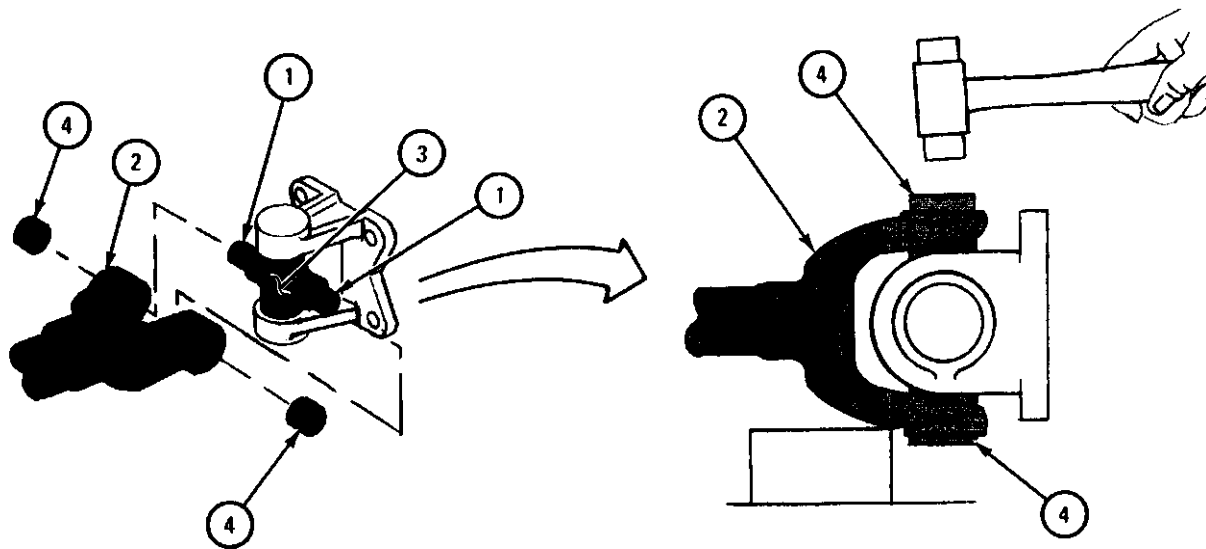

TA 047197

FRAME 3

1. If working on snapping type, using retaining ring pliers, put four retaining rings (1) in place as shown.
2. If working on C-ring type, using retaining ring pliers, put two retaining rings (2) in place as shown.

NOTE

If universal joint binds, tap retaining ring ends of bearings very lightly. This will relieve pressure on journal ends.

3. Using grease gun, lubricate universal joint. Refer to LO 9-2320-209-12/1.

END OF TASK

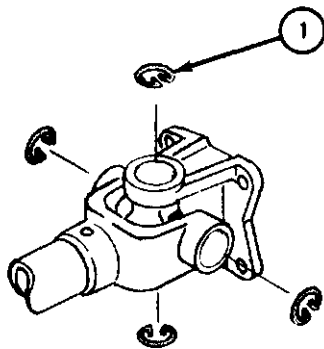

SNAPRING TYPE

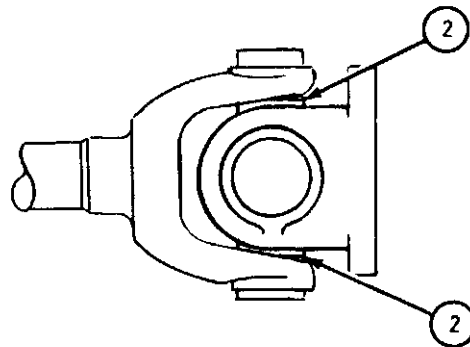

C-RING TYPE

TA 047516

f. Assembly (Bearing Cap Type).

FRAME 1

1. Put four retainers (1) and four gaskets (2) on journals (3).
2. Screw grease fitting (4) into spider (5) and tighten, using 5/16-inch wrench.
3. Put spider (5) into flange yoke (6) by tilting spider as necessary.
4. Using fingers, press two bearing caps (7) over two journals (3) through holes in yoke (6).
5. Place assembly on a wood block as shown. Hold spider (5) in place and tap each bearing cap (7) into yoke (6), using rawhide mallet.

GO TO FRAME 2

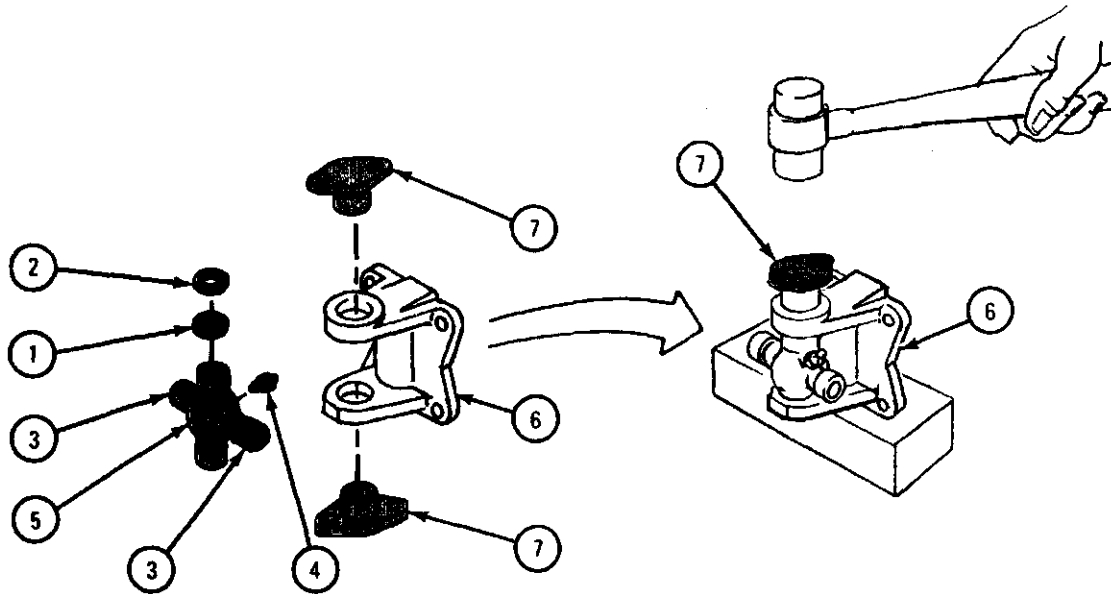

TA 101708

FRAME 2

1. Put journals (1) into holes in shaft yoke (2) as shown by tilting spider (3).
2. Using fingers, press two bearing caps (4) over ends of journals (1) through holes in shaft yoke (2) as shown.
3. Using rawhide mallet, tap each bearing cap (4) into shaft yoke (2).

GO TO FRAME 3

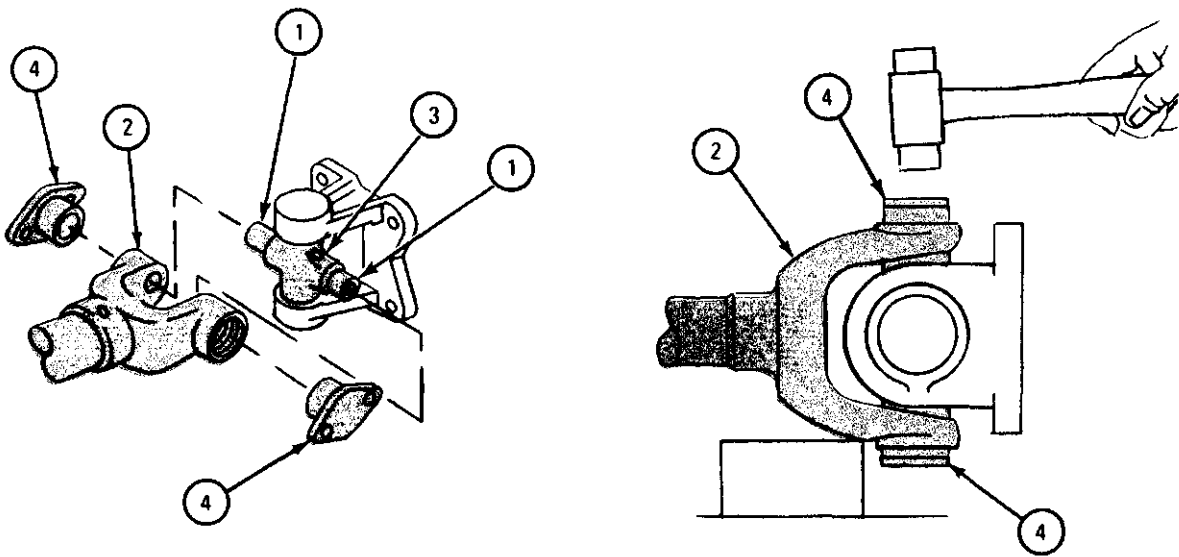

TA 101709

FRAME 3

1. Put four locking straps (1) over four bearing caps (2).
2. Screw eight bolts (3) through locking straps (1) and bearing caps (2). Using 9/16-inch wrench, tighten bolts.
3. Using screwdriver, bend up eight locking strap lugs (4) against bolt heads (3).

NOTE

If universal joint binds, tap bearing caps lightly. This will relieve pressure on journal ends.

4. Using grease gun, lubricate universal joint. Refer to LO 9-2320-209-12/1.

END OF TASK

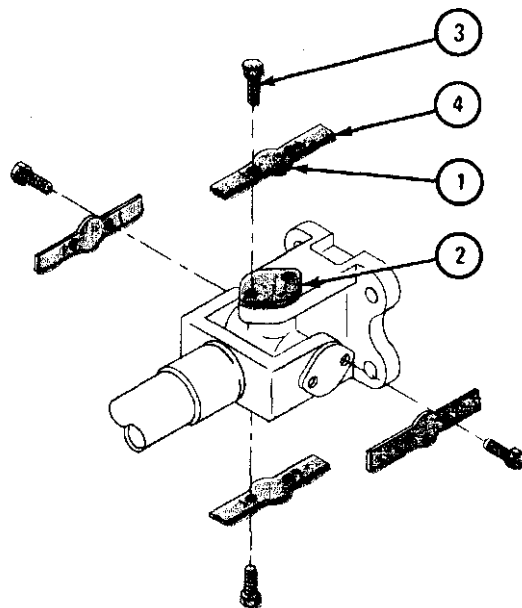

TA 047198

CHAPTER 11

FRONT AXLE GROUP MAINTENANCE

Section I. SCOPE

11-1. EQUIPMENT ITEMS COVERED. This chapter gives equipment maintenance procedures for the front axle assembly and the steering mechanism for which there are authorized corrective maintenance tasks at the organizational maintenance level.

11-2. EQUIPMENT ITEMS NOT COVERED. All equipment items for which corrective maintenance is authorized at the organizational maintenance level are covered in this chapter.

Section II. FRONT AXLE ASSEMBLY

11-3. JACKING AND SUPPORTING AXLE HOUSING.

WARNING

Never work under truck with only one jack supporting truck. Truck may slip off jack. Weight of truck must be supported by trestles or support stands, with capacity for weight of truck.

TOOLS: Floor jack or jack supplied with truck, minimum capacity 8 tons
Trestles, motor vehicle, minimum capacity 5 tons (2)

SUPPLIES: None

PERSONNEL: One

EQUIPMENT CONDITION: Truck parked, engine off, handbrake set, wheels chocked.

a. Jacking and Supporting Front Axle Housing.

FRAME 1

1. Put jack (1) under axle housing (2). Turn knob (3) all the way to right and move handle (4) up and down to raise truck. Put two trestles (5) in place under each end of axle housing (2) as shown.
2. Turn knob (3) slowly to left to lower truck onto two trestles (5). Take jack (1) out from under truck.

END OF TASK

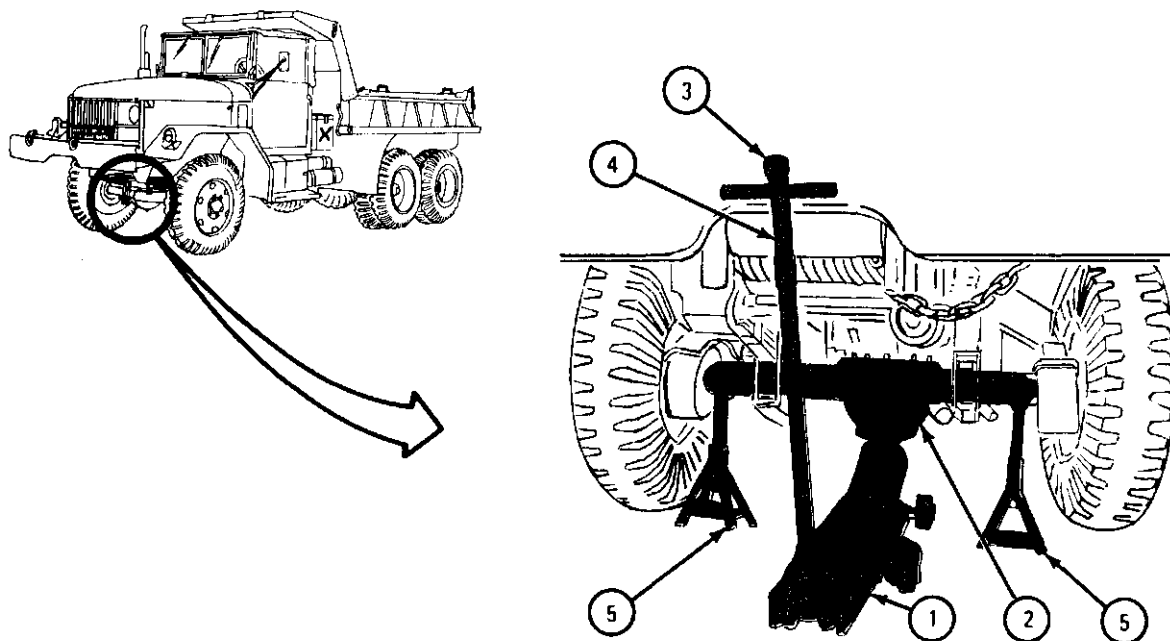

TA 045547

b. Removal of Front Axle Housing Supports.

FRAME 1

1. Put jack (1) in place under axle housing (2). Turn knob (3) all the way to right and move handle (4) up and down to raise truck until trestles (5) are free. Take trestles out from under truck.
2. Turn knob (3) slowly to left and lower truck to ground. Take jack (1) out from under truck.

END OF TASK

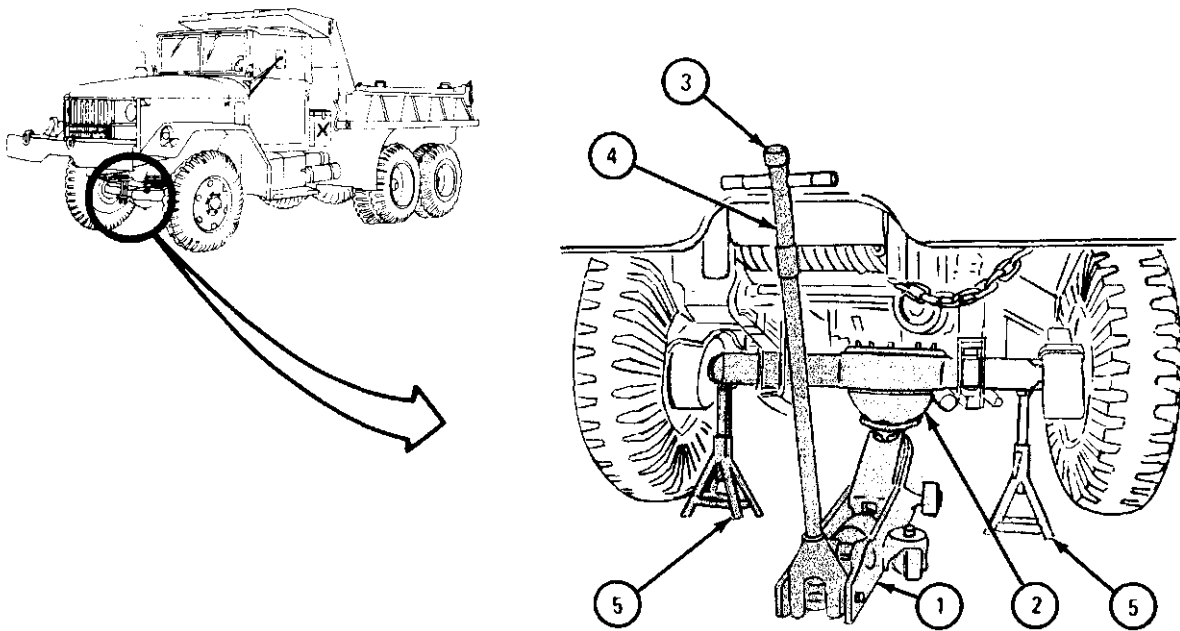

TA 045547

c. Jacking and Supporting Rear Axle Housing.

FRAME 1

1. Put jack (1) in place under rear axle housing (2). Turn knob (3) all the way to right and move handle (4) up and down to raise truck. Put two trestles (5) under each end of rear axle housing (2).
2. Turn knob (3) slowly to left and lower truck onto two trestles (5). Take jack (1) out from under truck.
3. Do steps 1 and 2 again on other rear axle housing.

END OF TASK

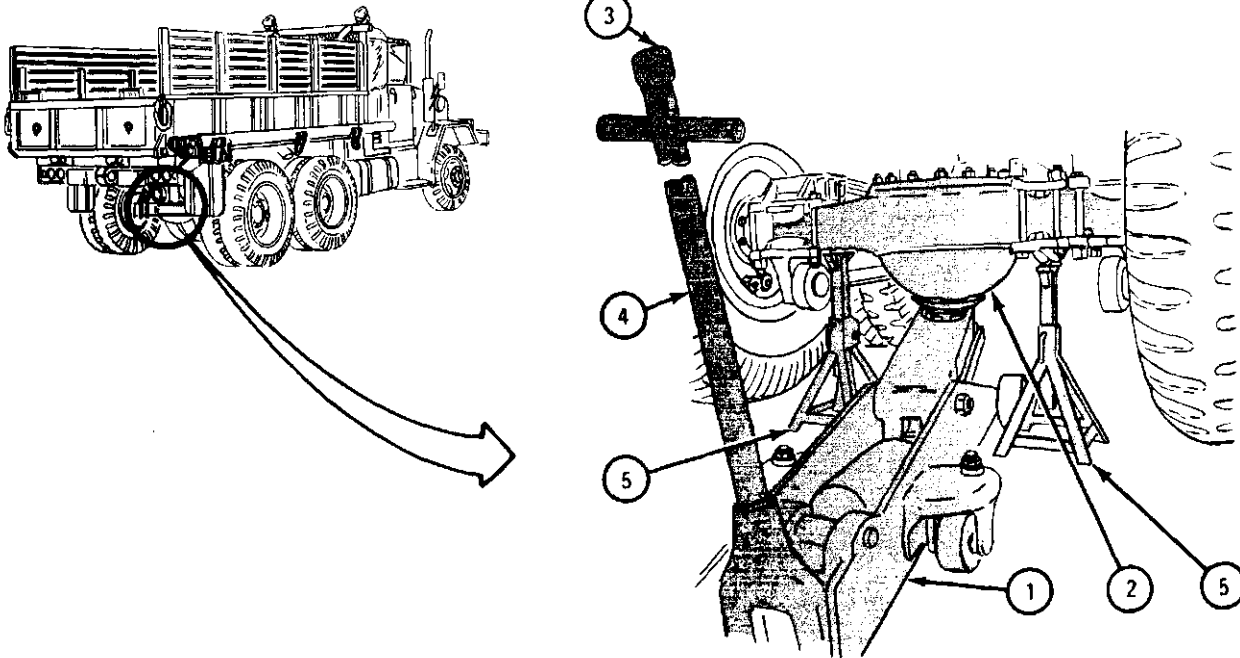

TA 045548

d. Removal of Rear Axle Housing Supports.**FRAME 1**

1. Put jack (1) in place under forward-rear axle housing (2). Turn knob (3) all the way to right and move handle (4) up and down to raise truck until two trestles (5) are free. Take trestles out from under truck.
2. Turn knob (3) slowly to left and lower axle housing (2) to ground. Take jack (1) out from under truck.
3. Do steps 1 and 2 again on rear-rear axle housing.

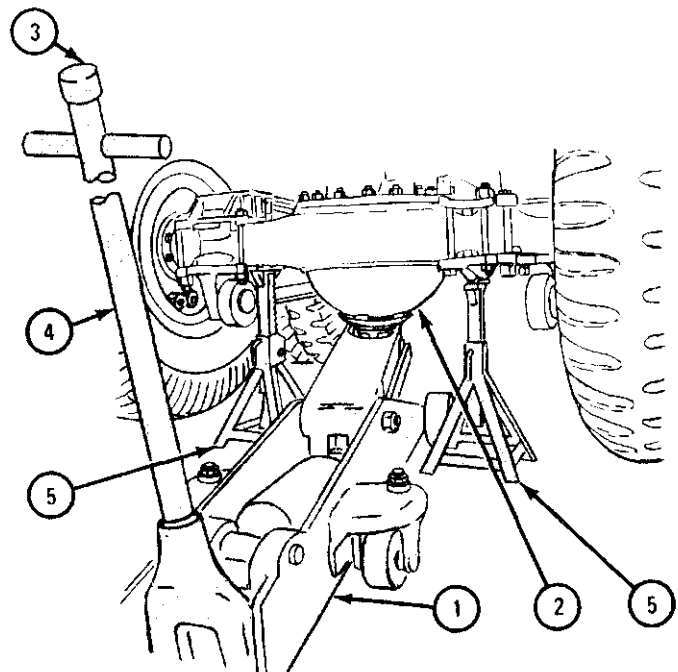
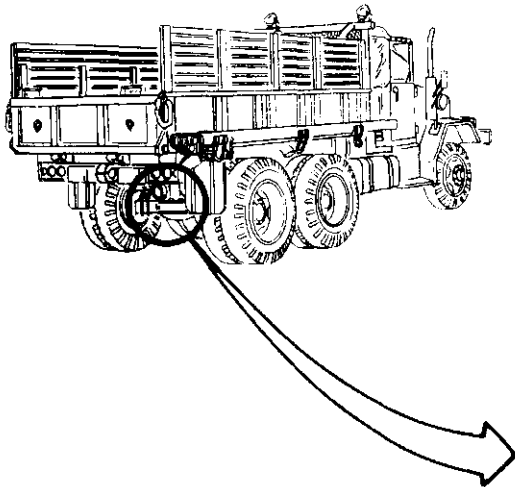

TA 045548

11-4. JACKING AND SUPPORTING TRUCK CHASSIS.

- TOOLS: Hydraulic floor jack
Wheel chocks (4)
Motor vehicle trestle (4)
Wood block, 8 x 8 x 24 inches (8)
Wood block, 8 x 8 x 42 inches (4)
Chock blocks (2)

SUPPLIES: None

PERSONNEL: One

EQUIPMENT CONDITION: Truck parked, engine off, handbrake set.

a. Raising Front Chassis.

FRAME 1

1. Chock rear wheels.
2. Put hydraulic jack under axle housing (1) as shown.

WARNING

Keep hands away from front wheels when jacking truck.
Wheels may turn as they clear the ground and cause injury to personnel.

3. Using hydraulic jack, jack up truck until front wheels (2) are six inches off the ground.
4. Lay two 42-inch wood blocks (3) under chassis (4) and two 24-inch wood blocks (5) next to each other on top of wood blocks (3). Put trestle (6) on top of four wood blocks as shown.
5. Put two 24-inch wood blocks (5) and trestle (6) on other end of the 42-inch wood blocks (3) under chassis (4) on other side of truck.
6. Using hydraulic jack, lower truck onto two trestles (6).

END OF TASK

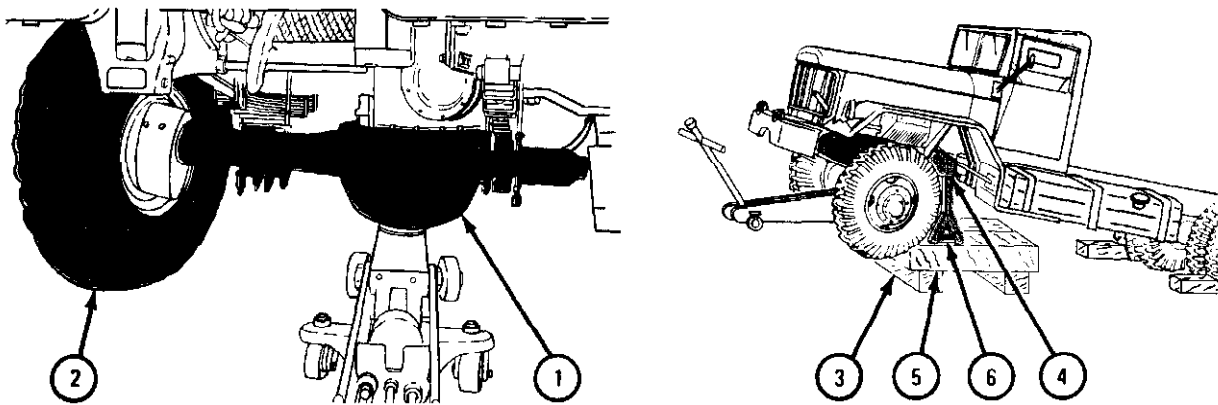

TA 084072

b. Lowering Front Chassis.**FRAME 1**

1. Put hydraulic jack under axle housing (1) as shown.
2. Jack up truck until truck is off two trestles (2).
3. Take out two trestles (2) and six wood blocks.
4. Using hydraulic jack, lower truck onto ground and take away hydraulic jack.
5. Take away wheel chocks (3) from rear wheels.

END OF TASK

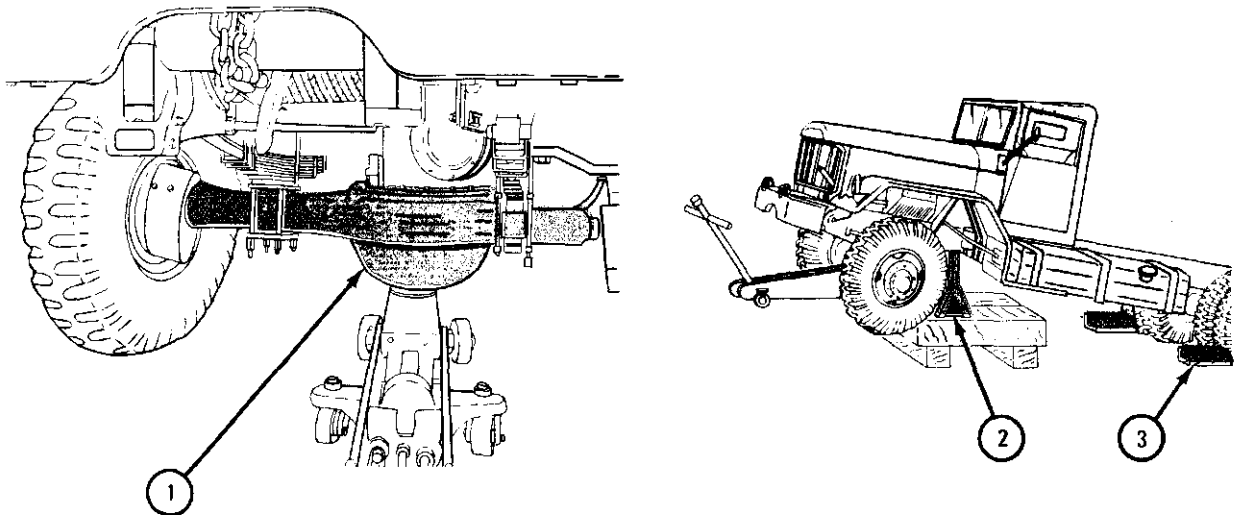

TA 084073

c. Raising Rear of Chassis (One Side).

FRAME 1

1. Chock front wheels as shown.
2. Put hydraulic jack under crosstube bracket (1) as shown. Jack up truck until rear wheels (2) are six inches off the ground.
3. put four 42-inch wood blocks (3) under truck as Shown.
4. Put four 24-inch wood blocks (4) on top of each set of wood blocks (3) as shown.
5. Put one trestle (5) on top of each set of wood blocks (4) and set trestles under chassis (6).
6. Using hydraulic jack, lower truck onto trestles (5) and take away hydraulic jack.

END OF TASK

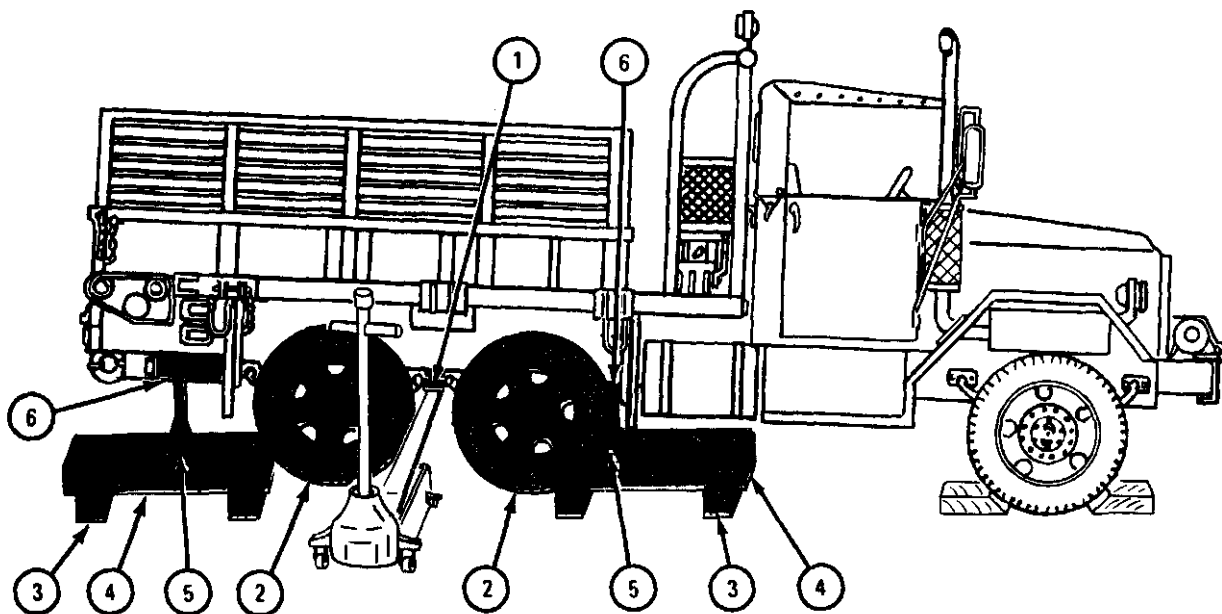

TA 084074

d. Lowering Rear of Chassis (One Side).

FRAME 1

1. Put hydraulic jack under crosstube bracket (1) as shown. Jack up truck until weight of truck is off two trestles (2).
2. Take out two trestles (2).
3. Take away eight wood blocks (3).
4. Using hydraulic jack, lower truck onto ground and take away hydraulic jack.
5. Take away wheel chocks (4) from front wheels.

END OF TASK

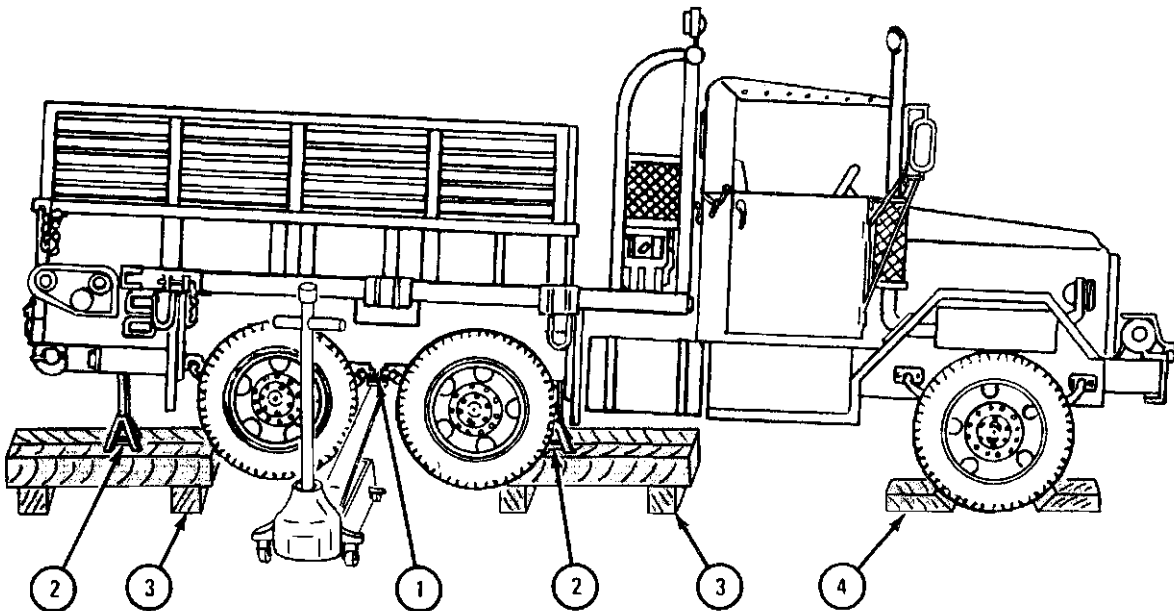

TA 084075

e. Raising Rear of Chassis (Both Sides).

FRAME 1

1. Chock front wheels as shown.
2. Put hydraulic jack under crosstube bracket (1) as shown. Jack up truck until rear wheels (2) are six inches off the ground.
3. Put four 42-inch wood blocks (3) under truck as shown.
4. Put four 24-inch wood blocks (4) on top of each set of wood blocks (3) as shown.
5. Put one trestle (5) on top of each set of wood blocks (4) and set trestles under chassis (6).
6. Using hydraulic jack, lower truck onto trestles (5) and take away hydraulic jack.
7. Using hydraulic jack, jack up other side of truck and do steps 4 through 6 again.

END OF TASK

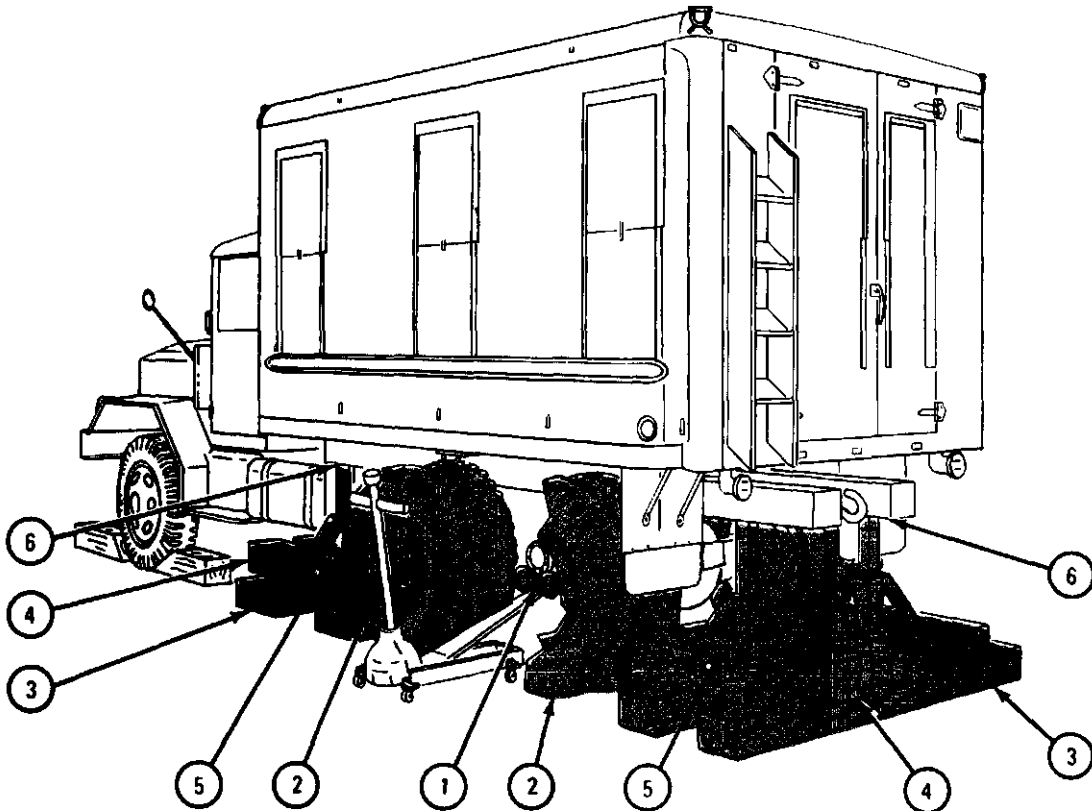

TA 084076

11-5. FRONT AXLE SHAFT ASSEMBLY REMOVAL AND REPLACEMENT.

TOOLS: 9/16-inch socket wrench Seal puller
 1-gallon container Brass punch
 3/4-inch wrench Hammer

SUPPLIES: None

PERSONNEL: One

EQUIPMENT CONDITION: Truck parked on level surface, engine off, handbrake set, rear wheels chocked.

a. Preliminary Procedures.

- (1) Jack up front of truck and support axle housing. Refer to para 11-3.
- (2) Remove brake hub and drum. Refer to Part 2, para 14-4.

b. Removal.

NOTE

Removal procedure is the same for left or right front axle shaft assemblies.

FRAME 1

- 1. Put container under brake assembly (1) to catch brake fluid,
- 2. Using 3/4-inch wrench, unscrew and take out screw (2). Take out two washers (3).
- 3. Using 9/16-inch socket wrench, unscrew and take off twelve nuts and lockwashers (4).
- 4. Take off dirt deflector (5).
- 5. Lift off brake plate assembly (1).

GO TO FRAME 2

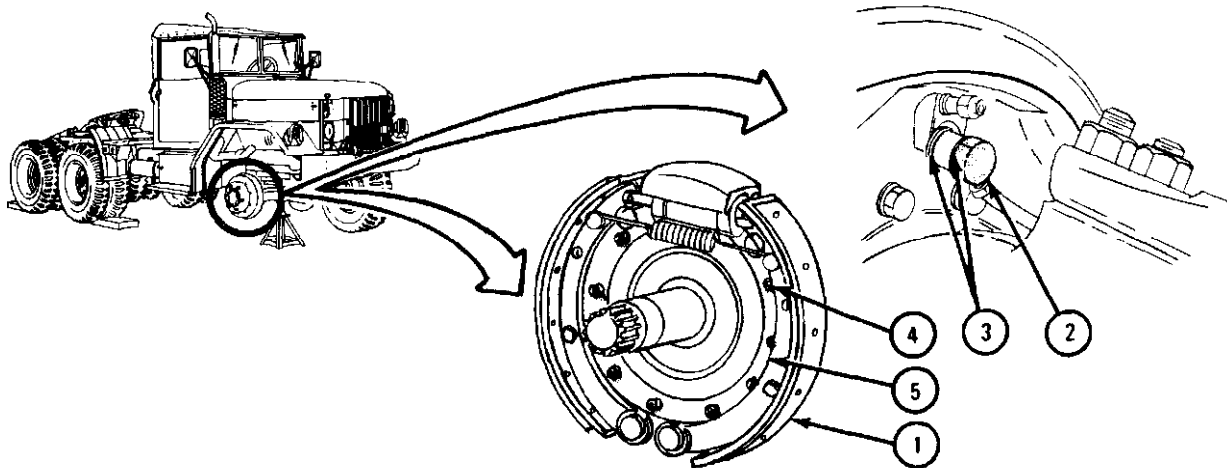

TA 047187

FRAME 2

1. Slide spindle (1) and thrust washer (2) off outer shaft of axle shaft assembly (3).
2. Carefully pull axle shaft assembly (3) out of axle housing (4) and steering knuckle housing (5).
3. Take inner shaft thrust washer (6) off inner shaft of axle shaft assembly (3).
4. Using puller, take seal assembly (7) out of axle housing (4) and throw seal away.

END OF TASK

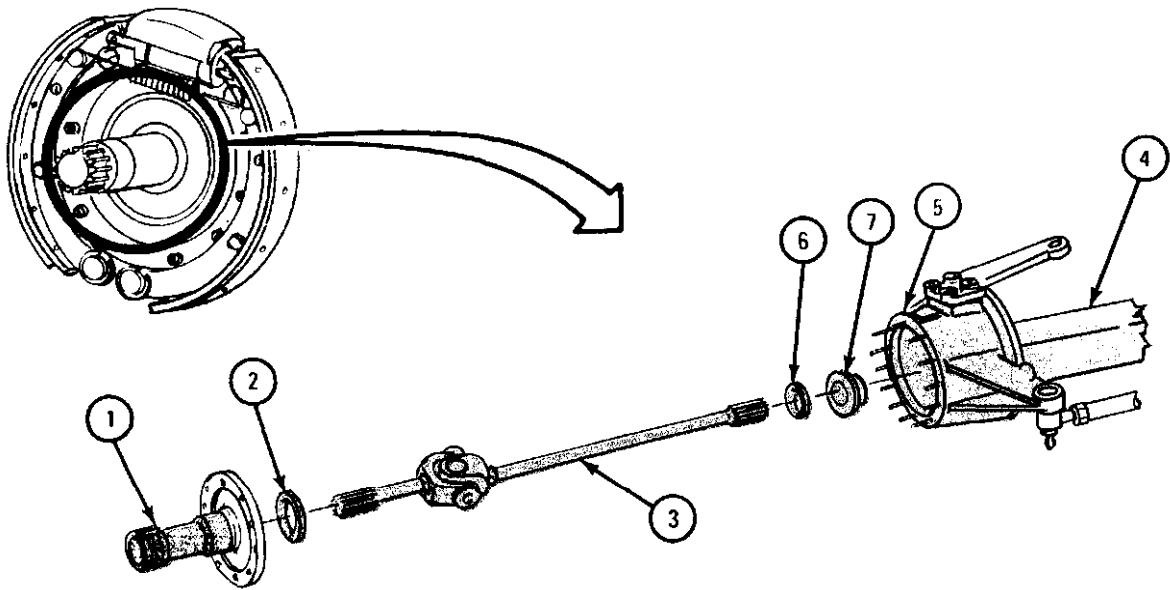

TA 047188

c. Replacement.

NOTE

Replacement procedure is same for left or right front axle shaft assemblies but the right assembly is shorter than the left.

FRAME 1

1. Put thrust washer (1) on short outer shaft (2) as shown. Beveled edge (3) must be toward universal joint (4).
2. Put thrust washer (5) on longer inner shaft (6) as shown. Beveled edge (7) must be toward universal joint (4).

GO TO FRAME 2

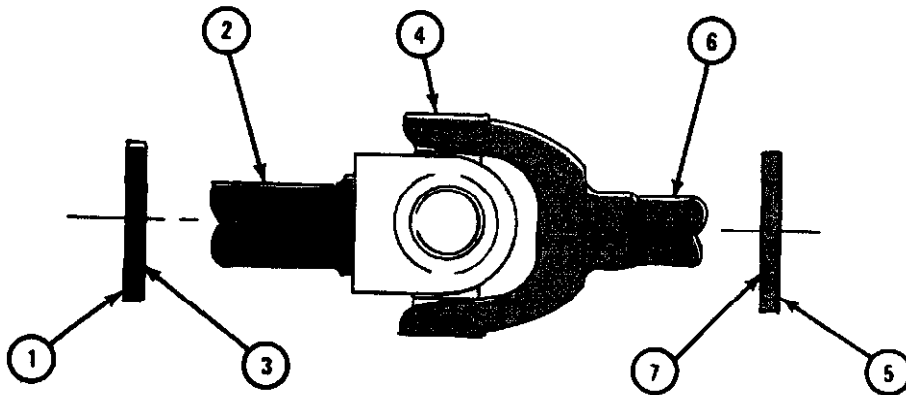

TA 047189

FRAME 2

1. Using brass punch and hammer, put seal assembly (1) into end of axle housing (2) as shown.

CAUTION

Be very careful not to damage seal assembly (1) when putting splined end of axle shaft assembly (3) into axle housing (2).

2. Put axle shaft assembly (3) with thrust washers (4) through steering knuckle housing (5) as shown.
3. Guide splined end (6) through axle housing (2) into splined differential side gear inside of housing.
4. Slide spindle assembly (7) onto outer shaft of axle shaft assembly (3).

GO TO FRAME 3

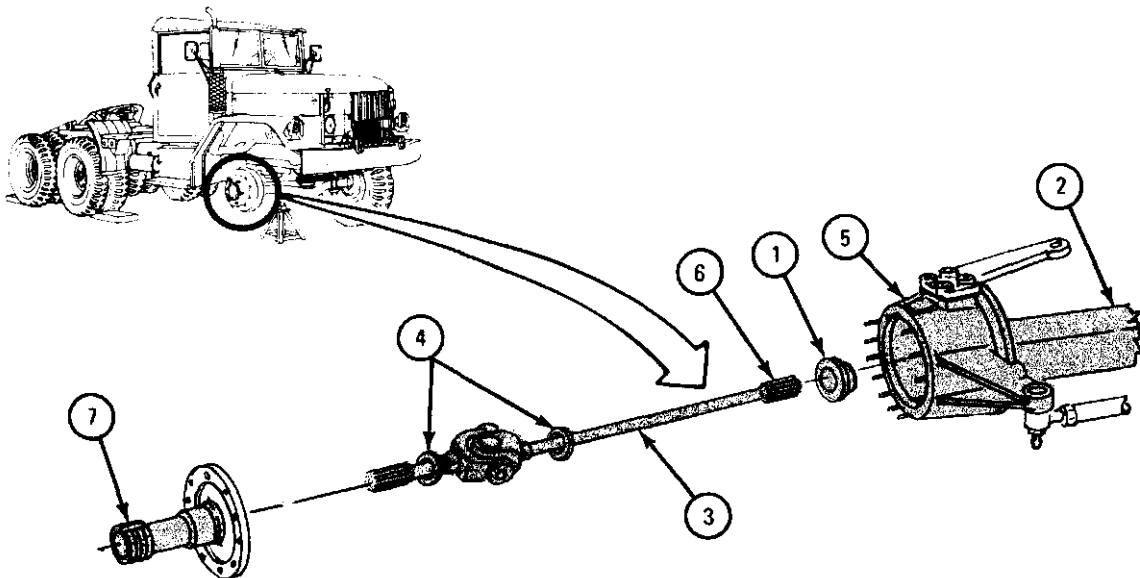

TA 047190

FRAME 3

1. Turn spindle assembly (1) until key slot (2) is at top. Aline holes and seat it firmly over 12 studs (3).

CAUTION

When putting on brake plate assembly (4), be careful not to damage hydraulic lines.

2. Put brake plate assembly (4) on spindle assembly (1) as shown. Aline holes and seat firmly over 12 studs (3).
3. Put dirt deflector (5) on spindle (1) as shown. Aline holes and seat firmly over 12 studs (3).
4. Using 9/16-inch socket wrench, screw on 12 nuts and lockwashers (6) and tighten them evenly.

GO TO FRAME 4

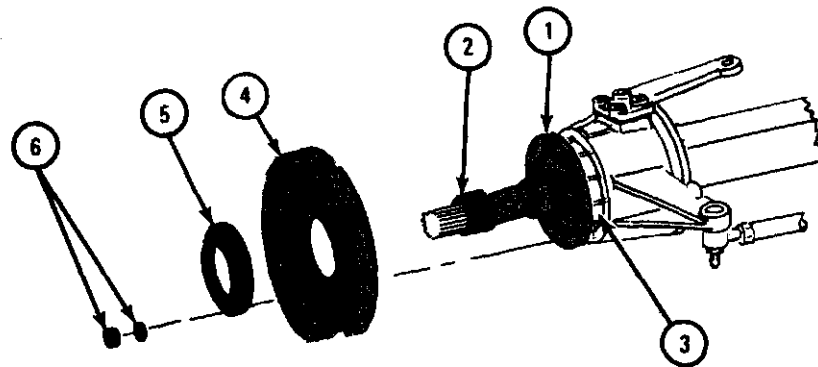

TA 047191

FRAME 4

1. Put hydraulic brake line (1) in place on brake assembly (2) and align holes.
2. Put screw (3) and two washers (4) in place as shown. Using 3/4-inch wrench, screw in and tighten screw.

NOTE

Follow-on Maintenance Action Required:

1. Replace brake drum and hub. Refer to Part 2, para 14-4.
2. Jack up front of truck, take out supports, and lower front of truck. Refer to para 11-3.
3. Bleed brakes. Refer to Part 2, para 13-15 and 13-16.
4. Remove rear wheels chocks.

END OF TASK

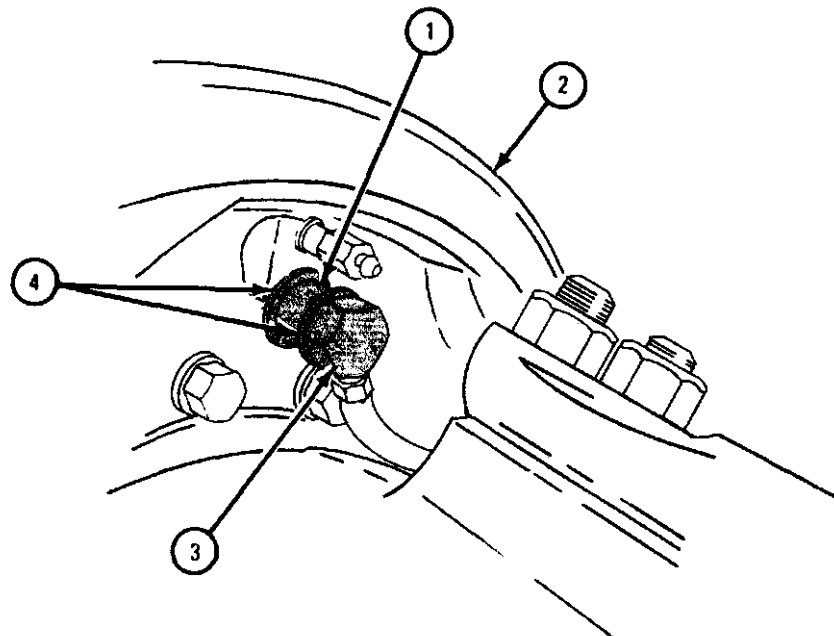

TA 082212

FRAME 2

NOTE

On left side of the truck, two nuts hold top of boot guard (5). On right side of the truck, two screws (1) hold top of boot guard. In this frame they are called fasteners.

1. Using 7/8-inch wrench, unscrew and take off two fasteners (1) and lock-washers (2).
2. Using 7/8-inch wrench, unscrew and take off two screws (3) and lock-washers (4).
3. Take off boot guard (5).

GO TO FRAME 3

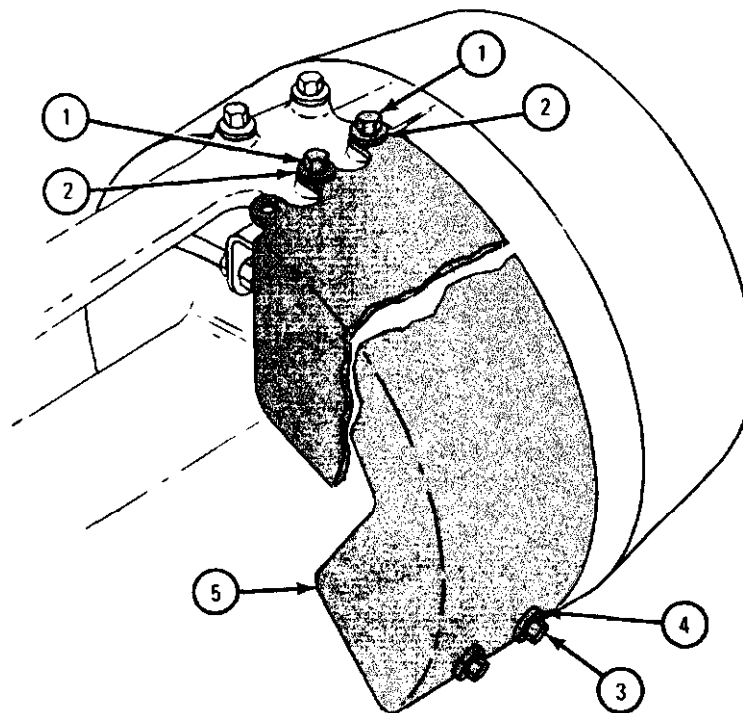

TA 046350

FRAME 3

1. Using 11/32-inch wrench, hold nut (1). Using screwdriver, loosen screw (2) so that clamp (3) can be taken off boot (4). Slide clamp off boot.
2. Pull boot (4) away from steering knuckle (5) all the way around.

GO TO FRAME 4

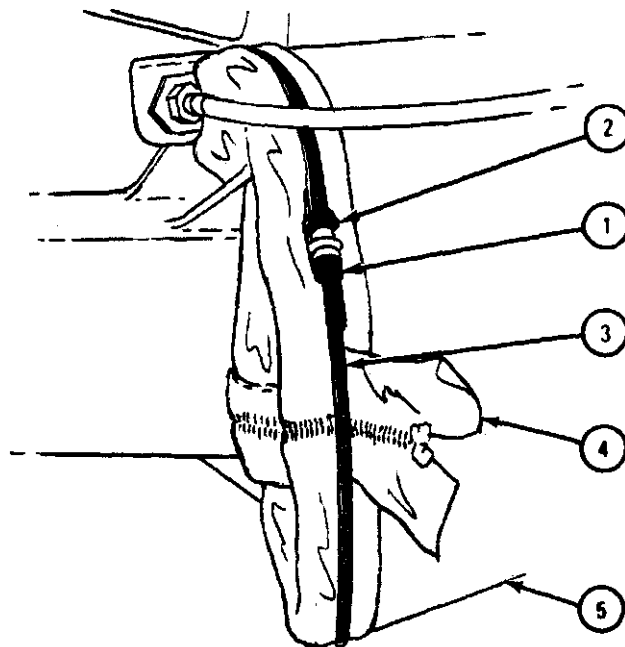

TA 046351

FRAME 4

1. Using 11/32-inch wrench, hold nut (1). Using screwdriver, loosen screw (2) so clamp (3) can be taken off boot (4).
2. Pull boot (4) away from axle housing (5) all the way around.
3. Using knife, cut boot (4) from A to B, as shown, and take off boot. Throw away boot.

END OF TASK

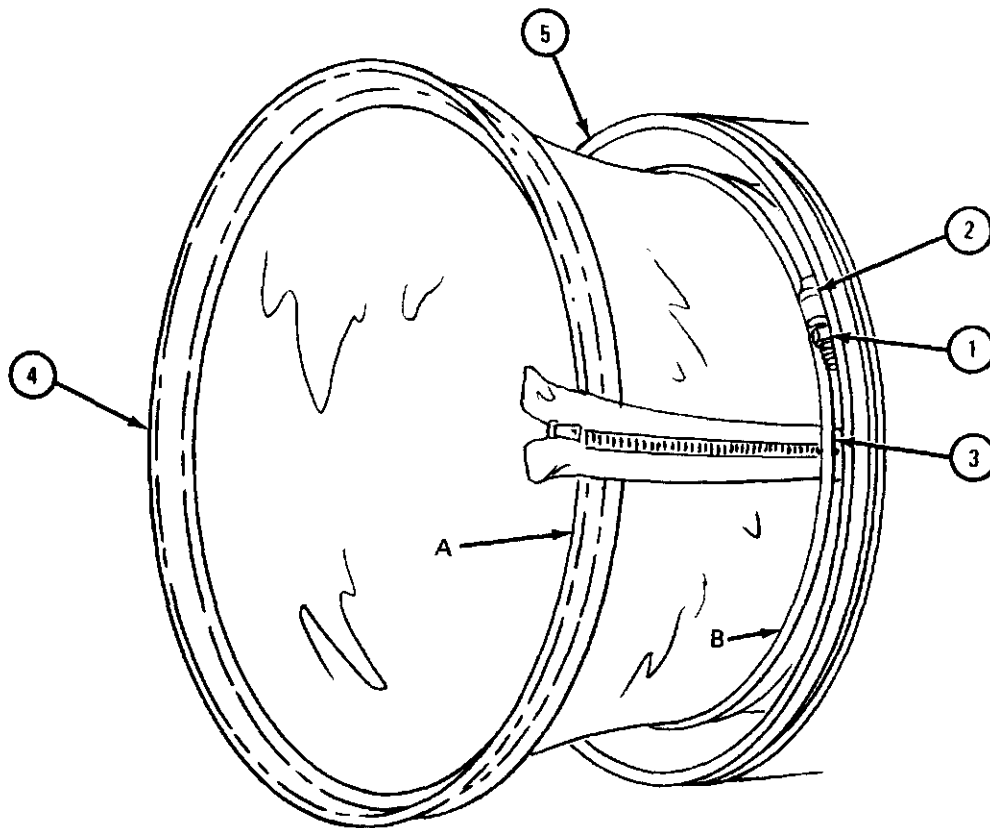

TA 046352

b. Replacement.

FRAME 1

NOTE

When boot is properly installed, the zipper will be to the front when on left wheel and to the rear when on right wheel.

1. Turn boot (1) inside out so tab on zipper (2) is on the outside. Put boot around axle (3) so small end is at steering knuckle (4).
2. Close zipper (2) all the way. Using cement (part of kit), seal all along zipper so it will not leak.
3. Hold boot (1) so the word TOP on boot is at highest point. Push boot onto axle housing (5) so boot clamp groove goes into axle housing clamp groove.
4. Put clamp (6) onto boot (1) clamp groove. Using 11/32-inch wrench, hold nut (7). Using screwdriver, tighten screw (8). Make sure clamp fits all the way around.

GO TO FRAME 2

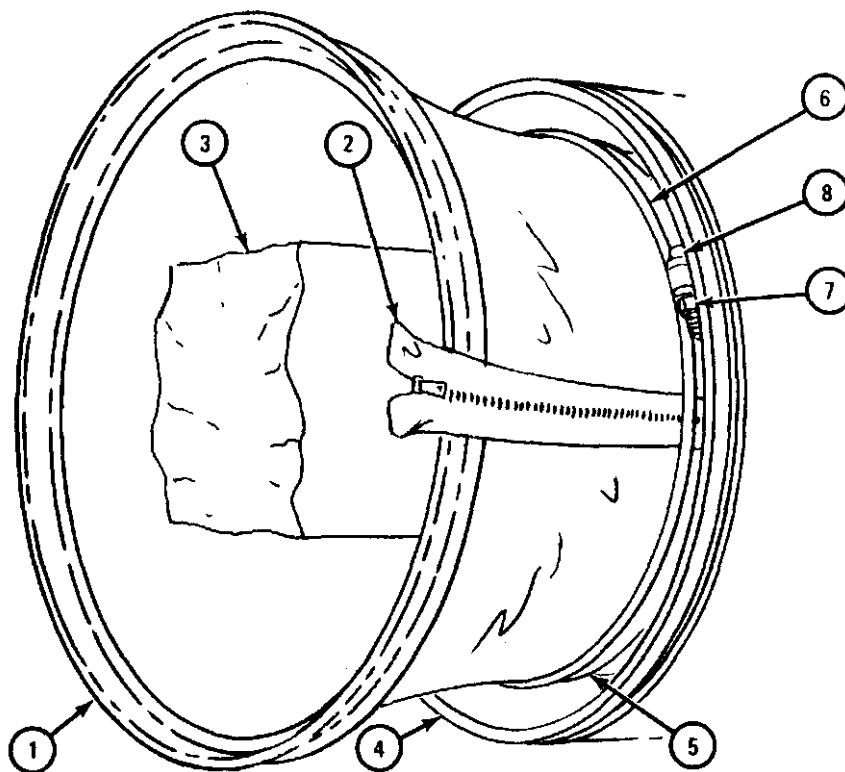

TA 046353

FRAME 2

1. Turn open end of boot (1) right side out, so zipper (2) is now inside.

CAUTION

Be careful not to twist boot (1) when putting it on.

2. Push open end of boot (1) over groove in steering knuckle (3).
3. Put clamp (4) over boot (1) so clamp will be in groove in steering knuckle (3). Using 11/32-inch wrench, hold nut (5). Using screwdriver, tighten screw (6).
4. Make sure that clamp (4) fits all the way around.
5. Lock zipper (2) in place using fine safety wire. Cut off excess wire.
6. Using cement, seal boot (1) all along cut edge (7) and outside of zipper (2).

GO TO FRAME 3

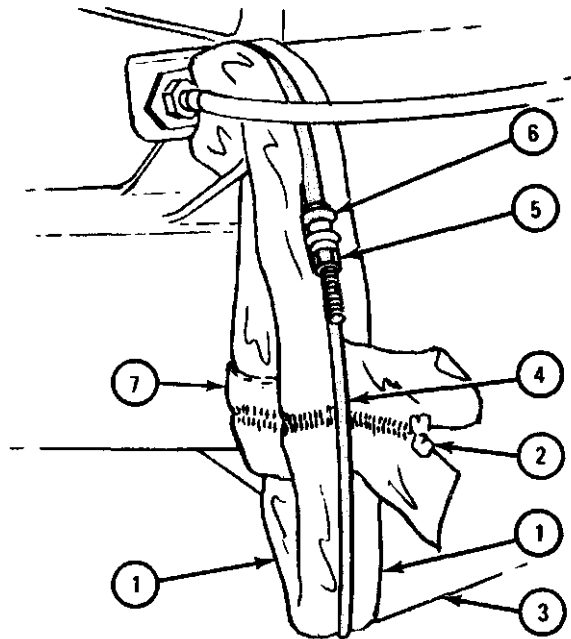

TA 046354

FRAME 3

NOTE

On left side of truck, two nuts hold top of boot guard (1). On right side of truck, two screws (3) hold top of boot guard. In this frame they are called fasteners.

1. Put boot guard (1) in place. Put lockwasher (2) on and using 7/8-inch wrench, screw on and tighten two fasteners (3).
2. Put lockwashers (4) on screws (5) and using 7/8-inch wrench, screw in and tighten screws.
3. Put screw (6) through bracket (7) and boot guard (1). Using 9/16-inch wrenches, screw on and tighten nut (8).

END OF TASK

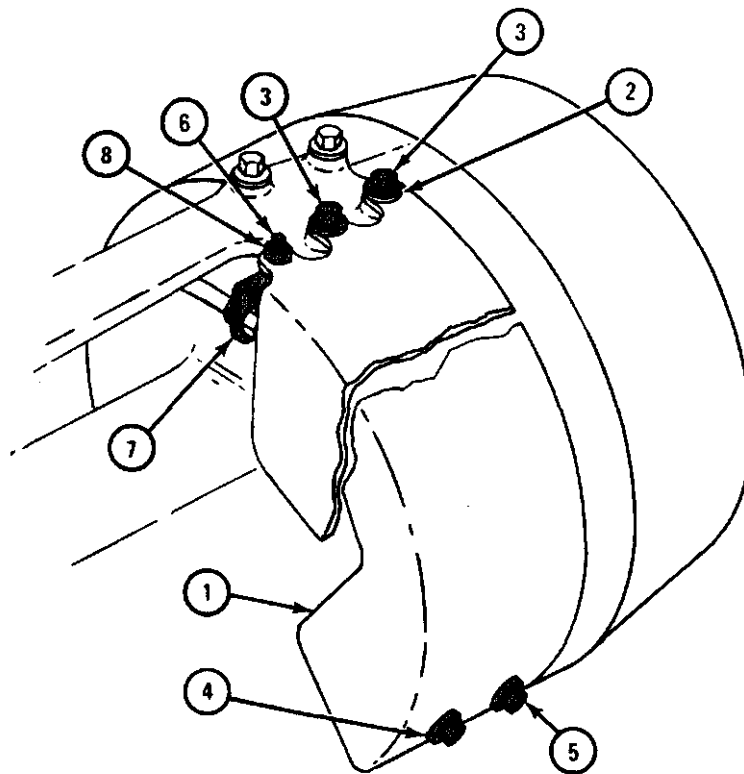

TA 046355

CHAPTER 12

REAR AXLE GROUP MAINTENANCE

Section I. SCOPE

12-1. EQUIPMENT ITEMS COVERED. This chapter gives equipment maintenance procedures for the rear axle assembly for which there are authorized corrective maintenance tasks at the organizational maintenance level.

12-2. EQUIPMENT ITEMS NOT COVERED. All equipment items for which corrective maintenance is authorized at the organizational maintenance level are covered in this chapter.

Section II. REAR AXLE ASSEMBLY

12-3. REAR AXLE SHAFT REMOVAL AND REPLACEMENT.

TOOLS: 3/4-inch wrench
Torque wrench, 150 pound-feet capacity

SUPPLIES: Axle shaft gasket

PERSONNEL: One

EQUIPMENT CONDITION: Truck parked, engine off, handbrake set.

a. Removal.



FRAME 1

1. Using 3/4-inch wrench, unscrew and take out eight screws (1) and lock-washers (2).
2. Pull out and take away rear axle shaft (3). Throw away gasket (4).

END OF TASK

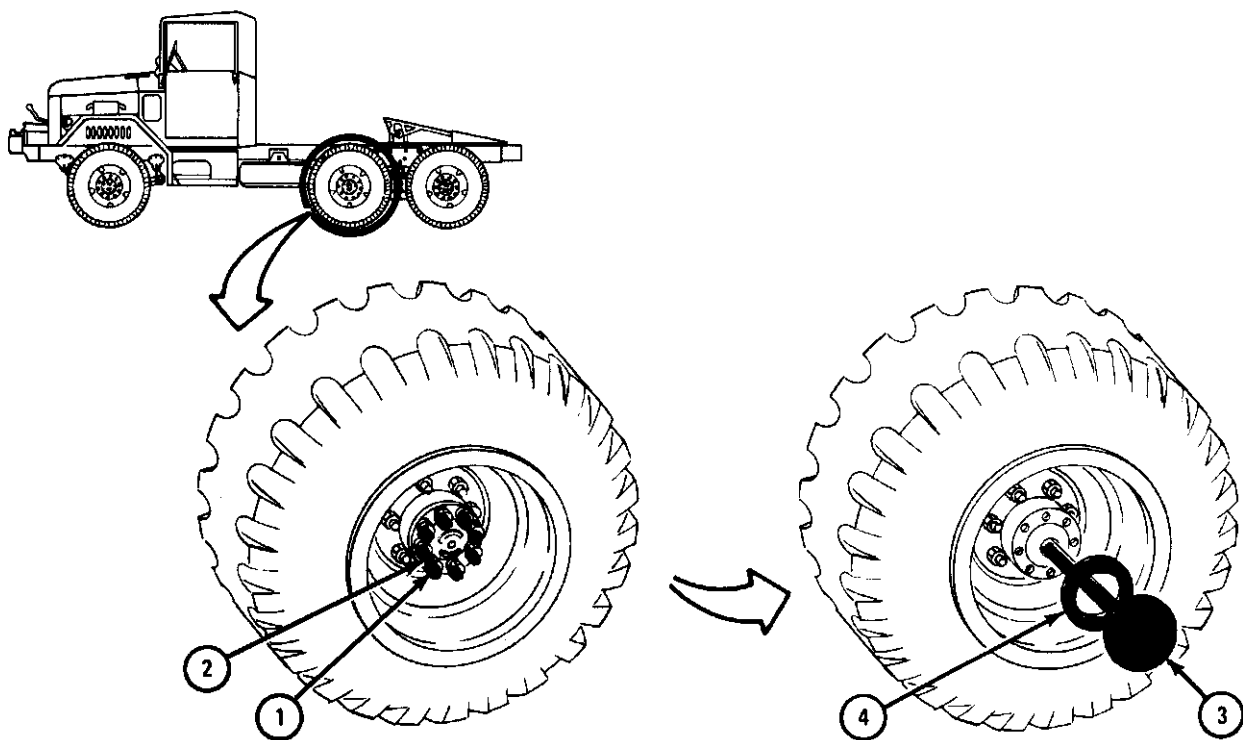

TA 046270

b. Replacement.

FRAME 1

NOTE

Check that rear axle shaft is clean before putting on gasket and putting in shaft.

1. Put gasket (1) on axle housing (2). Line up screw holes in gasket with holes in axle housing.
2. Put rear axle shaft (3) in axle housing (2) until it stops. Push down on flange end to aline inner spline end with differential bearing.

NOTE

The axle shaft flange will be about two inches from axle housing.

3. With inner end of axle shaft (3) into bearing, turn the axle shaft, until eight bolt holes in flange line up with eight bolt holes in the axle housing (2).
4. Put lockwashers (4) on eight screws (5). Put screws through rear axle shaft (3) and gasket (1). Using wrench, start screws into axle housing (2).
5. Using torque wrench, eight screws (5), tightening each screw a little at a time to 70 to 80 pound-feet.

END OF TASK

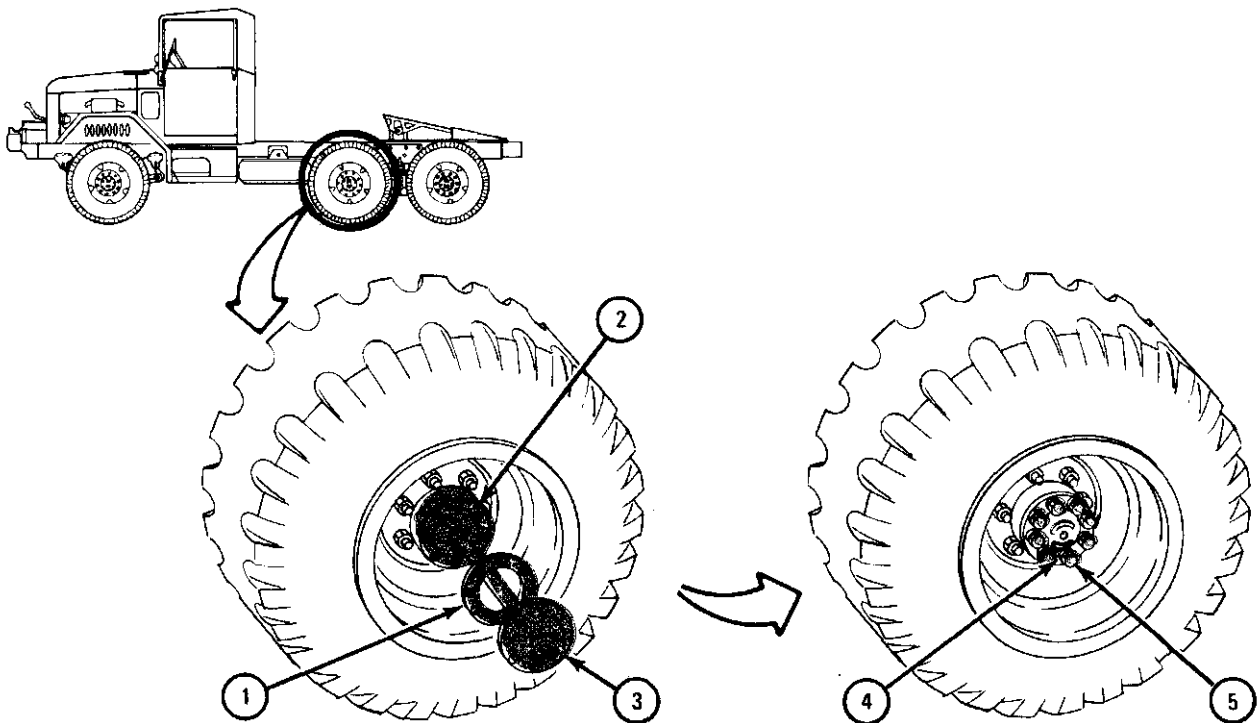

TA 046271

12-4. REAR AXLE BREATHER VALVE REMOVAL AND REPLACEMENT.

NOTE

This task is the same for both forward-rear axle and rear-rear axle breather valves.

TOOLS: 7/16-inch wrench

SUPPLIES: Solvent, dry cleaning, type II (SD-2), Fed. Spec P-D 680

PERSONNEL: One

EQUIPMENT CONDITION: Truck parked, engine off, handbrake set.

a. Removal.

FRAME 1

1. Using wrench, unscrew and take out air breather valve (1) from axle housing (2).

END OF TASK

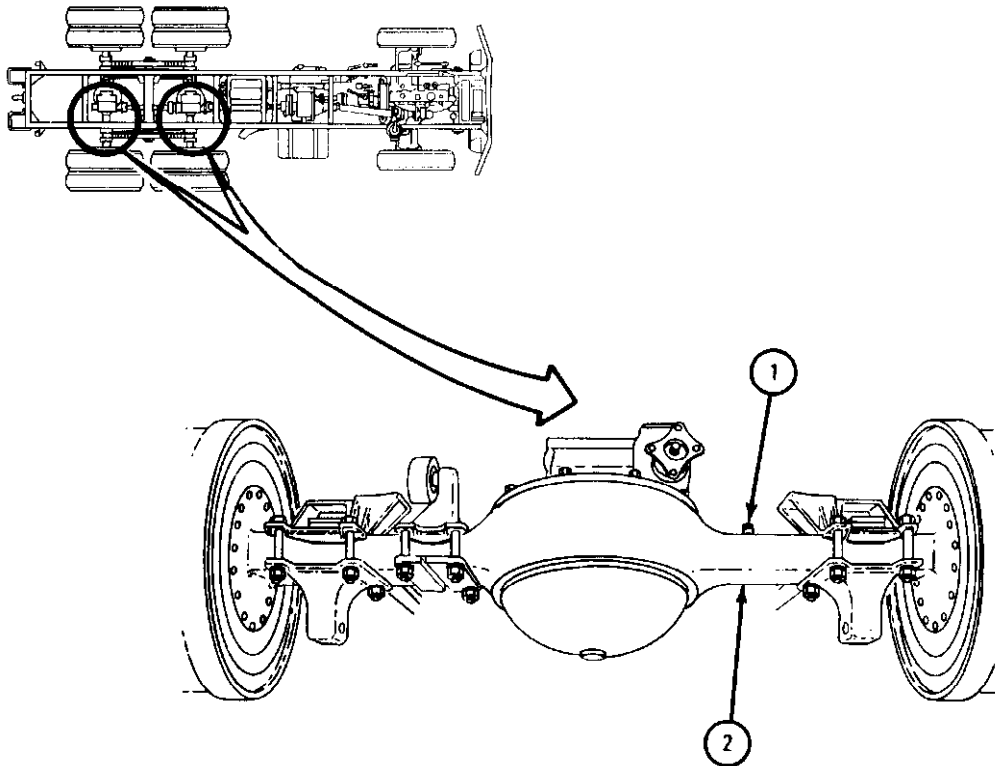

TA 083277

b. Replacement.**FRAME 1****WARNING**

Dry cleaning solvent is flammable. Do not use near an open flame. Keep a fire extinguisher nearby when solvent is used. Use only in well-ventilated places. Failure to do this may result in injury to personnel and damage to equipment.

1. Using solvent, clean air breather valve (1). Let valve dry.
2. Using 7/16-inch wrench, screw in and tighten air breather valve (1) into axle housing (2).

END OF TASK

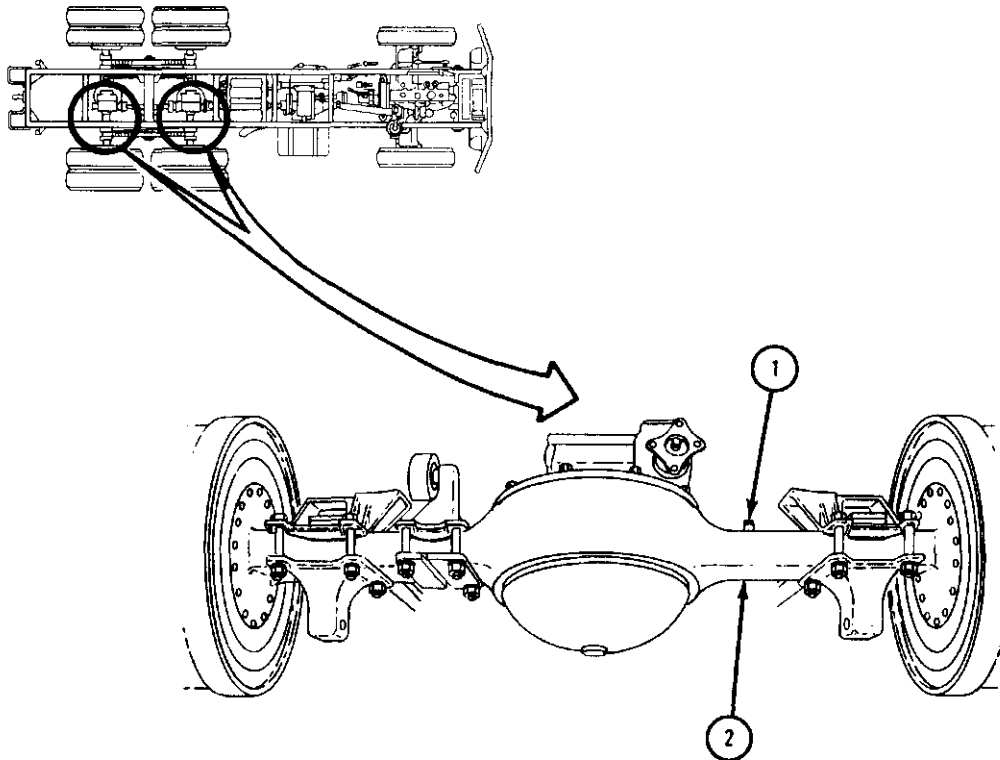

TA 083277

By Order of the Secretaries of the Army and the Air Force:

E. C. MEYER
General, United States Army
Chief of Staff

Official:

J. C. BENNINGTON
Major General, United States Army
The Adjutant General

LEW ALLEN, JR., General, USAF
Chief of Staff

Official:

VAN L. CRAWFORD, JR., Colonel, USAF
Director of Administration

Distribution:

To be distributed in accordance with DA Form 12-38, Organizational Maintenance requirements for 2-1/2-Ton Truck Cargo, 2-1/2-Ton Truck Van, etc.

RECOMMENDED CHANGES TO EQUIPMENT TECHNICAL PUBLICATIONS



THEN... JOT DOWN THE DOPE ABOUT IT ON THIS FORM, CAREFULLY TEAR IT OUT, FOLD IT AND DROP IT IN THE MAIL!

SOMETHING WRONG WITH THIS PUBLICATION?

FROM: (PRINT YOUR UNIT'S COMPLETE ADDRESS)

CDR, 1st Bn, 65th ADA
Attn: SP4 Jane Idone
Key West, FL 33040

DATE SENT

Date Sent In

PUBLICATION NUMBER

TM 9-2320-209-20-3-1

PUBLICATION DATE

27 May 81

PUBLICATION TITLE

ORGANIZATIONAL MAINTENANCE MANUAL

BE EXACT. PIN-POINT WHERE IT IS

PAGE NO	PARA-GRAPH	FIGURE NO	TABLE NO
4-86	4-16		
7-47	7-9 c		
10-11	10-4 b		

IN THIS SPACE TELL WHAT IS WRONG AND WHAT SHOULD BE DONE ABOUT IT:

Subparagraph a refers to para 7-5 in step (2). Should read para 7-58.

Change illustration callouts.
Reason: Callouts for plug (1) and switch (2) are reversed.

FRAME 2, step 4 reads "Using wrench, tighten nuts (6)." Should read "Using wrench, tighten nuts (5 and 6)."

SAMPLE

PRINTED NAME GRADE OR TITLE AND TELEPHONE NUMBER

SP4 Jane Idone Autovon 222-2224

SIGN HERE

Jane Idone

FILL IN YOUR
UNIT'S ADDRESS

FOLD

DEPARTMENT OF THE ARMY

POSTAGE AND FEES PAID
DEPARTMENT OF THE ARMY
DOD 314



OFFICIAL BUSINESS
PENALTY FOR PRIVATE USE \$.

SAMPLE

TEAR ALONG PERFORATED LINE

Commander
U.S. Army Tank-Automotive Command
ATTN: DRSTA-MB
Warren, MI 48090

FILL IN YOUR
UNIT'S ADDRESS

FOLD BACK

DEPARTMENT OF THE ARMY

POSTAGE AND FEES PAID
DEPARTMENT OF THE ARMY
DOD 314



OFFICIAL BUSINESS
PENALTY FOR PRIVATE USE \$300

TEAR ALONG PERFORATED LINE

Commander
U.S. Army Tank-Automotive Command
ATTN: DRSTA-MB
Warren, MI 48090

FILL IN YOUR
UNIT'S ADDRESS

FOLD BACK

DEPARTMENT OF THE ARMY

POSTAGE AND FEES PAID
DEPARTMENT OF THE ARMY
DOD 314



TEAR ALONG PERFORATED LINE

OFFICIAL BUSINESS
PENALTY FOR PRIVATE USE \$300

Commander
U.S. Army Tank-Automotive Command
ATTN: DRSTA-MB
Warren, MI 48090

RECOMMENDED CHANGES TO EQUIPMENT TECHNICAL PUBLICATIONS



THEN... JOT DOWN THE DOPE ABOUT IT ON THIS FORM, CAREFULLY TEAR IT OUT, FOLD IT AND DROP IT IN THE MAIL!

SOMETHING WRONG WITH THIS PUBLICATION?

FROM (PRINT YOUR UNIT'S COMPLETE ADDRESS)

DATE SENT

PUBLICATION NUMBER

TM 9-2320-209-20-3-1

PUBLICATION DATE

27 May 81

PUBLICATION TITLE

ORGANIZATIONAL MAINTENANCE MANUAL

BE EXACT... PIN-POINT WHERE IT IS

PAGE NO	PARA-GRAPH	FIGURE NO	TABLE NO

IN THIS SPACE TELL WHAT IS WRONG AND WHAT SHOULD BE DONE ABOUT IT:

PRINTED NAME GRADE OR TITLE AND TELEPHONE NUMBER

SIGN HERE

FILL IN YOUR
UNIT'S ADDRESS

FOLD BACK

DEPARTMENT OF THE ARMY

POSTAGE AND FEES PAID
DEPARTMENT OF THE ARMY
DOD 314



OFFICIAL BUSINESS
PENALTY FOR PRIVATE USE \$300

Commander
U.S. Army Tank-Automotive Command
ATTN: DRSTA-MB
Warren, MI 48090

TEAR ALONG PERFORATED LINE

THE METRIC SYSTEM AND EQUIVALENTS

LINEAR MEASURE

1 Centimeter = 10 Millimeters = 0.01 Meters = 0.3937 Inches
 1 Meter = 100 Centimeters = 1000 Millimeters = 39.37 Inches
 1 Kilometer = 1000 Meters = 0.621 Miles

WEIGHTS

1 Gram = 0.001 Kilograms = 1000 Milligrams = 0.035 Ounces
 1 Kilogram = 1000 Grams = 2.2 Lb
 1 Metric Ton = 1000 Kilograms = 1 Megagram = 1.1 Short Tons

LIQUID MEASURE

1 Milliliter = 0.001 Liters = 0.0338 Fluid Ounces
 1 Liter = 1000 Milliliters = 33.82 Fluid Ounces

SQUARE MEASURE

1 Sq Centimeter = 100 Sq Millimeters = 0.155 Sq Inches
 1 Sq Meter = 10,000 Sq Centimeters = 10.76 Sq Feet
 1 Sq Kilometer = 1,000,000 Sq Meters = 0.386 Sq Miles

CUBIC MEASURE

1 Cu Centimeter = 1000 Cu Millimeters = 0.06 Cu Inches
 1 Cu Meter = 1,000,000 Cu Centimeters = 35.31 Cu Feet

TEMPERATURE

$5/9 (^{\circ}\text{F} - 32) = ^{\circ}\text{C}$
 212^o Fahrenheit is equivalent to 100^o Celsius
 90^o Fahrenheit is equivalent to 32.2^o Celsius
 32^o Fahrenheit is equivalent to 0^o Celsius
 $9/5 \text{ C}^{\circ} + 32 = \text{F}^{\circ}$

APPROXIMATE CONVERSION FACTORS

<u>TO CHANGE</u>	<u>TO</u>	<u>MULTIPLY BY</u>
Inches	Centimeters	2.540
Feet	Meters	0.305
Yards	Meters	0.914
Miles	Kilometers	1.609
Square Inches	Square Centimeters	6.451
Square Feet	Square Meters	0.093
Square Yards	Square Meters	0.836
Square Miles	Square Kilometers	2.590
Acres	Square Hectometers	0.405
Cubic Feet	Cubic Meters	0.028
Cubic Yards	Cubic Meters	0.765
Fluid Ounces	Milliliters	29.573
Pints	Liters	0.473
Quarts	Liters	0.946
Gallons	Liters	3.785
Ounces	Grams	28.349
Pounds	Kilograms	0.454
Short Tons	Metric Tons	0.907
Pound-Feet	Newton-Meters	1.356
Pounds per Square Inch	Kilopascals	6.895
Miles per Gallon	Kilometers per Liter	0.425
Miles per Hour	Kilometers per Hour	1.609

<u>TO CHANGE</u>	<u>TO</u>	<u>MULTIPLY BY</u>
Centimeters	Inches	0.394
Meters	Feet	3.280
Meters	Yards	1.094
Kilometers	Miles	0.621
Square Centimeters	Square Inches	0.155
Square Meters	Square Feet	10.764
Square Meters	Square Yards	1.196
Square Kilometers	Square Miles	0.386
Square Hectometers	Acres	2.471
Cubic Meters	Cubic Feet	35.315
Cubic Meters	Cubic Yards	1.308
Milliliters	Fluid Ounces	0.034
Liters	Pints	2.113
Liters	Quarts	1.057
Liters	Gallons	0.264
Grams	Ounces	0.035
Kilograms	Pounds	2.205
Metric Tons	Short Tons	1.102
Newton-Meters	Pound-Feet	0.738
Kilopascals	Pounds per Square Inch	0.145
Kilometers per Liter	Miles per Gallon	2.354
Kilometers per Hour	Miles per Hour	0.621

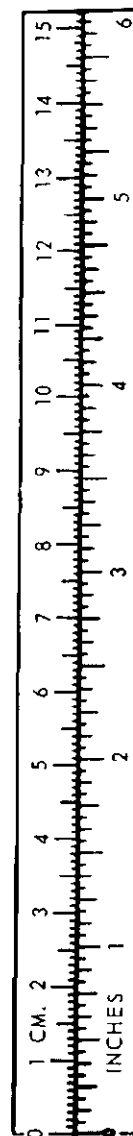

TA089991

