

LUBRICATION ORDER
26 JANUARY 1996

ARMY LO 9-2320-386-12
AIR FORCE TO 36A12-1B-1121LC-1

2-1/2 TON, 6X6, M44A3

ESP VEHICLES:

TRUCK, CARGO, FIXED SIDE: M35A3;

TRUCK, CARGO, DROPSIDE: M35A3C;

TRUCK, CARGO, LONG WHEELBASE: M36A3

REFERENCE: TM 9-2320-209-10-HR, TM 9-2320-386-10, TM 9-2320-386-24

This Lubrication Order is for crew (C) and unit (O) maintenance and provides the lubrication requirements needed to support components of the Extended Service Program vehicles. Included are fluid capacities, locations, intervals, and proper materials needed for lubricating the vehicles under normal and unusual conditions.

Service Intervals Under Normal Conditions. Service intervals are for normal operation of the vehicle in moderate temperatures, humidity, and atmospheric conditions. The intervals are hard-time intervals which are performed in accordance with the vehicle's age, calendar, or usage such as rating time or mileage. The hard-time intervals shown in this LO are based on mileage and calendar times. An example of mileage and calendar intervals is: 3/S; 3 stands for 3,000 miles (4,827 km), and S stands for semiannually (every six months). The lubrication for the vehicle is to be performed at whichever interval occurs first.

For equipment under manufacturer's warranty, hard-time oil service intervals shall be followed. Hard-time intervals may be shortened if your lubricants are contaminated, or if your vehicle has

been operated under adverse conditions, including longer-than-usual operating hours. Hard-time intervals may be extended during periods of low activity, although adequate preservation precautions must be taken. Hard-time intervals will be applied in the event AOAP laboratory support is not available.

Service Intervals Under Unusual Conditions. Increase the frequency of lubricating service when operating under abnormal conditions, such as high or low temperatures, prolonged high-speed driving; or extended cross-country operations. Such operations can diminish a lubricant's protective quality.

Arctic Conditions. Refer to FM 9-207, Operation and Maintenance of Ordnance Materiel in Cold Weather (0° to -65°F) (-18° to -54°C), or table II, Fluid Capacities and Lubricant Requirements, page 3.

REPORTING ERRORS AND RECOMMENDING IMPROVEMENTS

You can help improve this Lubrication Order. If you find any mistakes, or if you know of a way to improve the procedures, please let us know. Your letter or DA Form 2028 (Recommended Changes to Publications) should be mailed directly to: Commander, U.S. Arm Tank-Automotive and Armaments Command, ATTN: AMSTA-IM-MTP, Warren, MI 48090. A reply will be furnished directly to you.

DISTRIBUTION STATEMENT A: Approved for public release; distribution is unlimited.

Corrosion Prevention and Control (CPC). Corrosion prevention and control (CPC) of Army materiel is a continuing concern. It is important that corrosion problems are reported so they can be corrected and improvements can be made to prevent future problems.

While corrosion is typically associated with rusting of metals, it can also include deterioration of other materials, such as rubber and plastic. Unusual cracking, softening, swelling, or breaking of these materials may be a corrosion problem.

If a corrosion problem is identified, it can be reported using Standard Form 368, Product Quality Deficiency Report. Use of key words such as corrosion, rust, deterioration, or cracking will ensure that the information is identified as a CPC problem.

The form should be submitted to the address specified in DA PAM 738-750.

Oil Filters. Oil filters shall be serviced/cleaned/changed/ as applicable, when:

1. They are known to be contaminated or clogged;
2. Service is recommended by AOAP laboratory analysis, or
3. Prescribed hard-time intervals are reached.

AOAP Requirements. Sample oil from all oil-wet components every 60 days or 1,000 miles (1,609 km). Reserve and National Guard units should perform oil sampling every 120 days or 1,000 miles (1,609 km). In the event AOAP laboratory support is not available, on-condition (OC) hard-time intervals may be applied.

WARNING

- Drycleaning solvent is flammable and will not be used near open flame. Use only in well-ventilated places. Failure to do so may result in injury to personnel.
- Keep all lubricants in a closed container and store in a clean, dry place, away from extreme heat. Failure to do so may result in injury to personnel.

CAUTION

Keep container covers clean and allow no dust, dirt, or other foreign material to mix with lubricants. Keep, all lubrication equipment clean and ready to use.

NOTE

Man hours have not been established.

Cleaning. Keep all external parts of equipment not requiring lubrication free of lubricants. Before lubricating equipment, clean fittings. Use drycleaning solvent, Type II (SD-2) (P-D-680) biodegradable, to wipe all lubrication points free of dirt and grease. Dry before lubricating. After servicing lubrication points, wipe off excess lubricants to prevent accumulation of foreign matter.

Table I. Interval and Lubrication Key.

The following is a list of service intervals, abbreviations, and keys, appearing in this LO.

OC	On-Condition, unless changed by the Army Oil Analysis Program (AOAP)
C/MR	Change gear lubricant only when required by maintenance repair action or if contaminated
D	Daily
W	Weekly
M	Monthly
S	Semiannually (6 months)
A	Annually (12 months)
B	Biennially (24 months)
1	1,000 mi (1,609 km)
3	3,000 mi (4,827 km)
6	6,000 mi (9,654 km)
12	12,000 mi (19,308 km)
24	24,000 mi (38,616 km)

The following is a list of lubricants and abbreviations for this LO.

OE/HDO	Lubricating oil, combustion engine, tactical (MIL-L-2104)
G o	Lubricating oil, gear, multi-purpose (MIL-L-2105)
BFS	Brake fluid, silicone (MIL-B-46176)
GAA	Grease, automotive and artillery (MIL-G-10924)
OEA	Lubricating oil, internal combustion engine, arctic (MIL-L-46167)
CW	Lubricating oil, chain, exposed gear, and wire rope (VV-L-751)

LUBRICATION TABLES

Table II. Fluid Capacities and Lubricant Requirements.

COMPONENT	CAPACITIES	EXPECTED TEMPERATURES		LUBRICANT MIL. SYMBOL (NATO CODE) SPECIFICATION
		°F	°C	
Engine	Crankcase Dry 21 qt (19.9 L)	-4 to +122	-20 to +50	SAE 15W40 (O-1236) MIL-L-2104
	W/filter 19 qt (18 L) W/o filter 18 qt (17 L)	-50 to -4	-46 to -20	OEA (O-183) MIL-L-46167
Transmission	Dry 21 qt (19.9 L)	+10 to +122	-12 to +50	SAE 15W40 (O-1236) MIL-L-2104
	Drain and refill 10 qt (9.5 L) After rebuild 16 qt (15.2 L)	-50 to +10	-46 to -12	OEA (O-183) MIL-L-46167
Winch Gear Case	2.75 pt (1.3 L)	-4 to +122	-20 to +50	GO 80/90 (O-226) MIL-L-2105
Winch End Frame Housing	1.25 pt (0.6 L)	-50 to -4	-46 to -20	GO 75 (O-186) MIL-L-2105
Winch Hydraulic System	Dry 42 qt (39.7 L)	-4 to +122	-20 to +50	SAE 15W40 (O-1236) MIL-L-2104
	Drain and refill 39 qt (36.9 L)	-50 to -4	-46 to -20	OEA (O-183) MIL-L-46167
Master Cylinder Reservoir	2 qt (1.9 L)	All Temperatures		BFS (H-547) MIL-B-46176
Front and Rear Axle Differentials	6 qt (5.7 L)	-4 to +122	-20 to +50	GO 80/90 (O-226) MIL-L-2105
		-50 to -4	-46 to -20	GO 75 (O-186) MIL-L-2105
Transfer Case	7 qt (6.6 L)	-4 to +122	-20 to +50	GO 80/90 (O-226) MIL-L-2105
		-50 to -4	-46 to -20	GO 75 (O-186) MIL-L-2105
Steering Gear	3.13 pt (1.48 L)	-4 to +122	-20 to +50	GO 80/90 (O-226) MIL-L-2105

INTERVAL • LUBRICANT

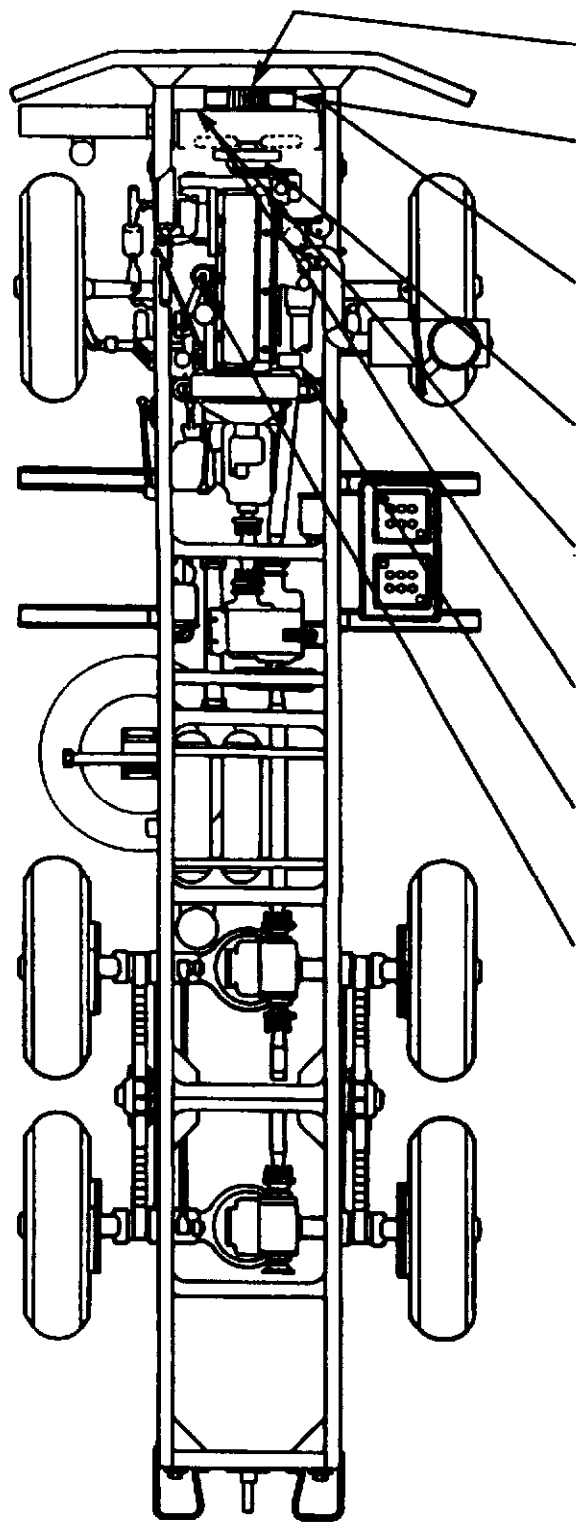

S	OE/HDO	Winch Cable (See note 2) (LV-A) (C)
C/MR	GO	Winch End Frame Housing (Drain and refill) (Cap. - 1.25 pt [0.6 L]) (See note 3) [LV-C, D] (O)
3/5	GO	Winch End Frame Housing Fill and Level (Check level) (See note 3) [LV-D] (O)
6	GAA	Accessory Drive Pulley (1 fitting) (Service) [LV-F] (O)
C/MR		Winch Worm Housing (Drain and refill) (Cap. 1.25 pt [0.6L]) (See note 3) [LV-B, E] (O)
3/5	GO	Winch Worm Housing Fill and Level (Check level) (See note 3) [LV-E] (O)
D	BFS	Master Cylinder Reservoir Fill and Level (Check level; fill to full line) (Cap. 2 qt [1.9 L]) (See note 5) [LV-J] (C)
6		Engine Crankcase Breather (Service) (See note 4) [LV-G] (O)

NOTE

Letters in brackets refer to localized views (LV). See pages 9 through 15.

CHASSIS - M35A3, M35A3C, M36A3

INTERVAL • LUBRICANT

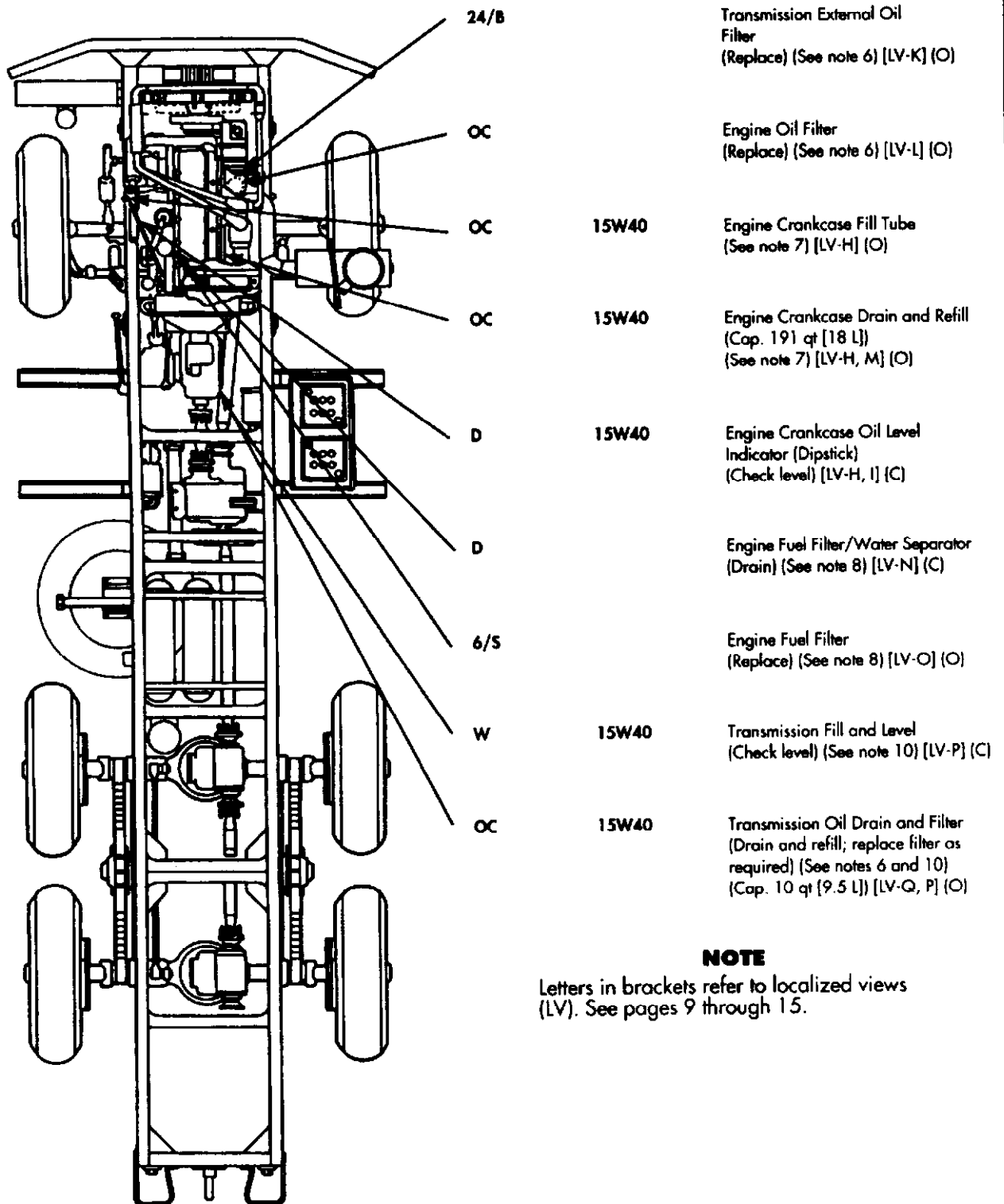

NOTE

Letters in brackets refer to localized views (LV). See pages 9 through 15.

CHASSIS - M35A3, M35A3C, M36A3

INTERVAL • LUBRICANT

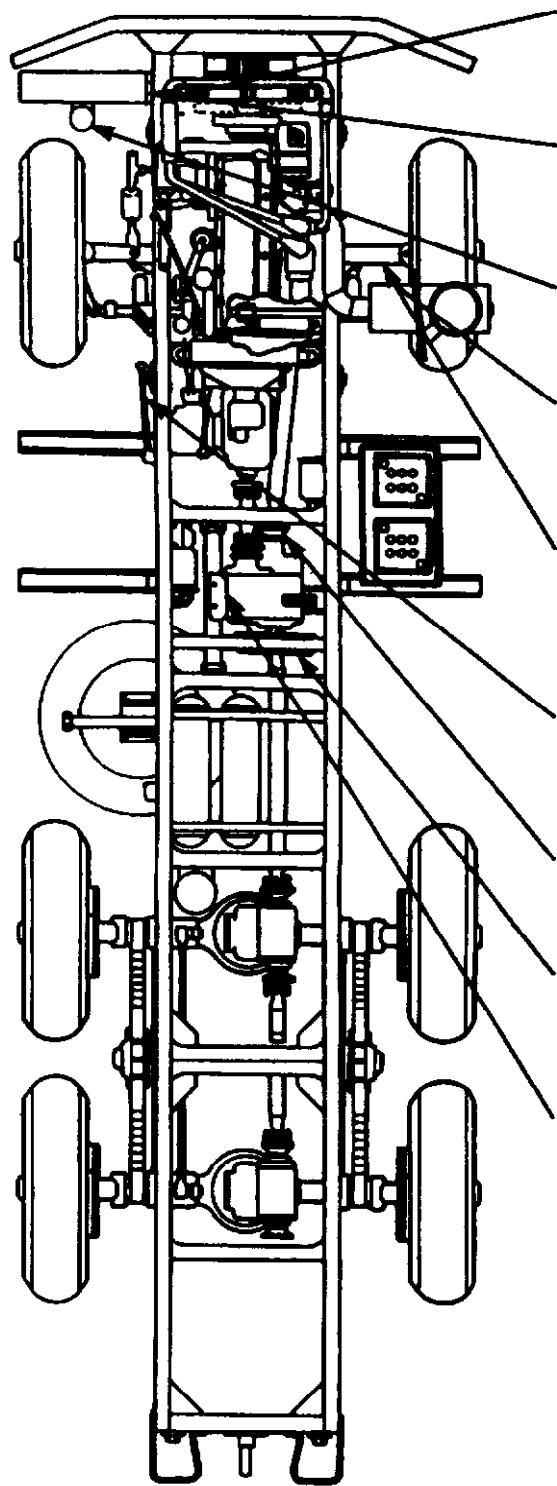

12/A	15W40	Winch Hydraulic Reservoir (Drain and refill) (Cap. 39 qt [36.9 L]) (See note 11) [LV-R, T] (O)
W	15W40	Winch Hydraulic Reservoir Fill and Level (Check level) (See note 11) [LV-U, R] (C)
12/A		Winch Oil Filter (Replace) (See note 6) [LV-S] (O)
3/S	GO	Front Axle Differential Fill and Level (Check level) (See note 3) [LV-V] (O)
C/MR	GO	Front Axle Differential (Drain and refill) (Cap. 6 qt [5.7 L]) (See note 3) [LV-W, V] (O)
3/S	GAA	Brake Pedal and Pedal Shaft Bracket (3 fittings) (Service) [LV-X] (O)
3/S	GO	Transfer Case Fill and Level (Check level) (See note 3) [LV-Y] (O)
3/S	GAA	Parking Brake Lever and Shoe Anchor Pins (4 fittings, sparingly) (Service) [LV-AC] (O)
C/MR	GO	Transfer Case (Drain and refill) (Cap. 7 qt [6.6 L]) (See note 3) [LV-Z] (O)

NOTE

Letters in brackets refer to localized views (LV). See pages 9 through 15.

CHASSIS - M35A3, M35A3C, M36A3

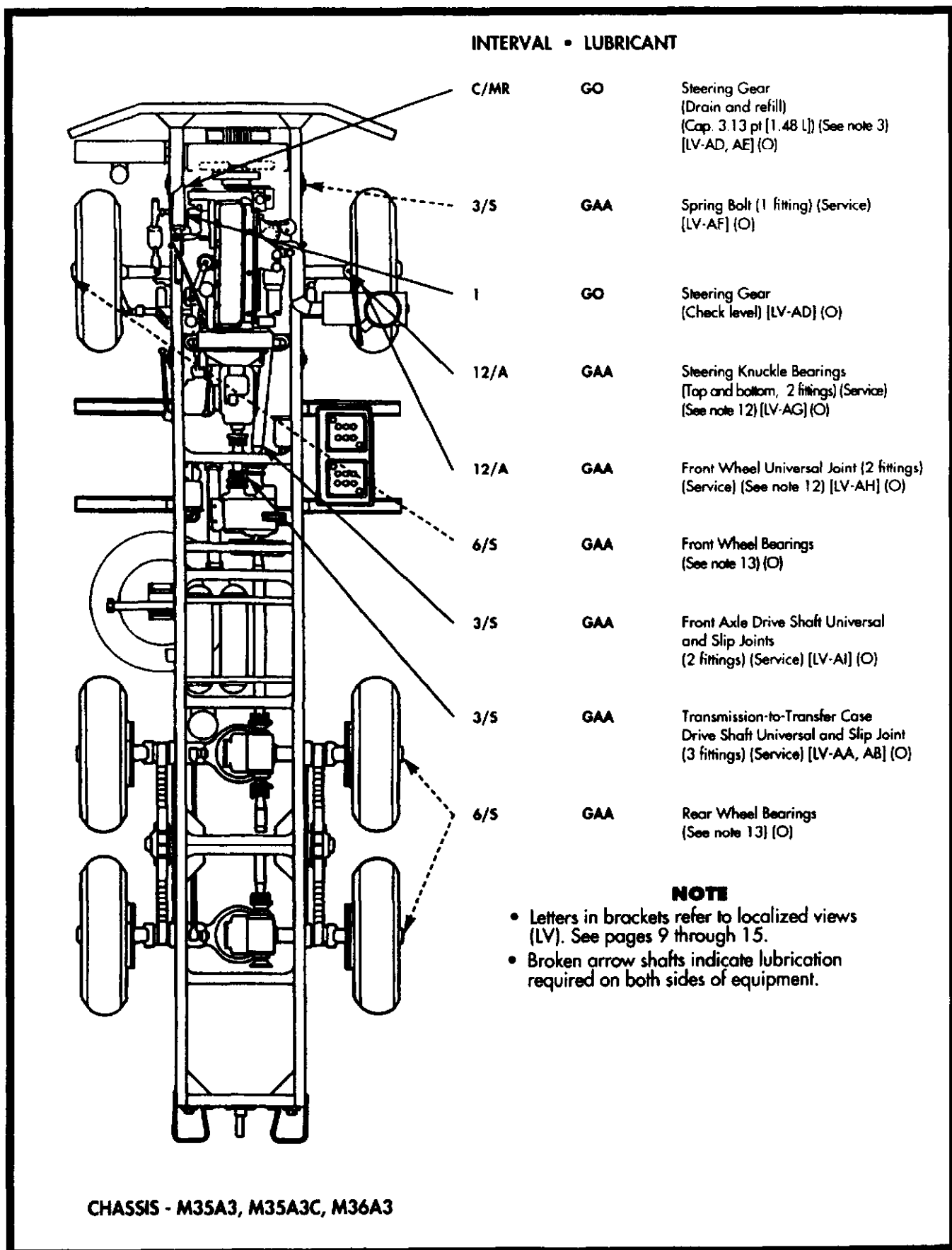

INTERVAL • LUBRICANT

Interval	Lubricant	Description
C/MR	GO	Steering Gear (Drain and refill) (Cap. 3.13 pt [1.48 L]) (See note 3) [LV-AD, AE] (O)
3/S	GAA	Spring Bolt (1 fitting) (Service) [LV-AF] (O)
1	GO	Steering Gear (Check level) [LV-AD] (O)
12/A	GAA	Steering Knuckle Bearings (Top and bottom, 2 fittings) (Service) (See note 12) [LV-AG] (O)
12/A	GAA	Front Wheel Universal Joint (2 fittings) (Service) (See note 12) [LV-AH] (O)
6/S	GAA	Front Wheel Bearings (See note 13) (O)
3/S	GAA	Front Axle Drive Shaft Universal and Slip Joints (2 fittings) (Service) [LV-AI] (O)
3/S	GAA	Transmission-to-Transfer Case Drive Shaft Universal and Slip Joint (3 fittings) (Service) [LV-AA, AB] (O)
6/S	GAA	Rear Wheel Bearings (See note 13) (O)

NOTE

- Letters in brackets refer to localized views (LV). See pages 9 through 15.
- Broken arrow shafts indicate lubrication required on both sides of equipment.

CHASSIS - M35A3, M35A3C, M36A3

INTERVAL • LUBRICANT

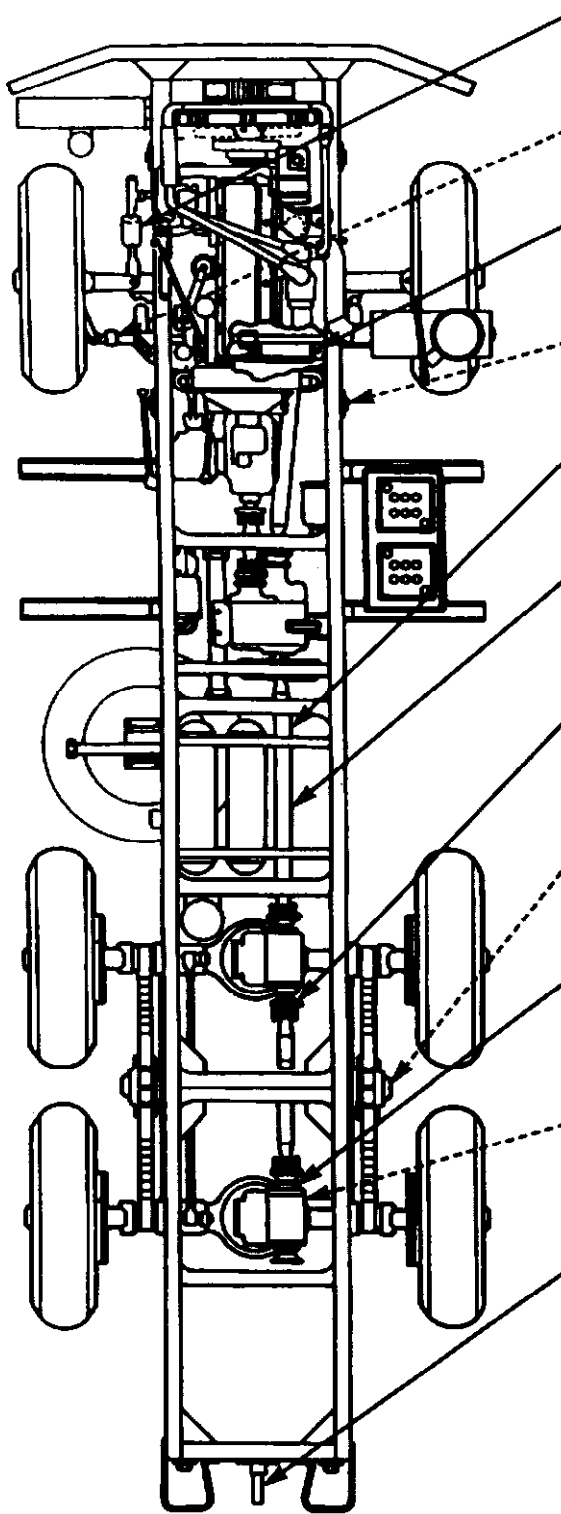

Interval	Lubricant	Description
W	GAA	Drag Link (2 fittings) (Service) [LV-AJ] (O)
3/S	GAA	Tie Rod (1 fitting) (Service) [LV-AK] (O)
W	GAA	Power Assist Cylinder (1 fitting) (Service) [LV-AL] (O)
3/S	GAA	Spring Shackles (2 fittings) (Service) (See note 14) [LV-AF] (O)
1/S	GAA	Drive Shaft Center Bearing (1 fitting) (Service) [M36A3] [LV-AM] (O)
3/S	GAA	Forward-Rear Axle Drive Shaft Universal and Slip Joints (3 fittings) (Service) [LV-AO] (O)
3/S	GAA	Rear Axle Drive Shaft Universal and Slip Joints (3 fittings) (Service) [LV-AO] (O)
3/S	GAA	Rear Spring Seat Bushing or Bearing (See note 9) [LV-AN] (O)
3/S	GO	Rear Axle Differential Fill and Level (Check level) (See note 3) [LV-V] (O)
C/MR	GO	Rear Axle Differential (Drain and refill) (Cap. 6 qt [5.7 L]) (See note 3) [LV-W, V] (O)
1/M	GAA	Pinrite (4 fittings) (Service) [LV-AP] (O)

NOTE

- Letters in brackets refer to localized views (LV). See pages 9 through 15.
- Broken arrow shafts indicate lubrication required on both sides of equipment.

CHASSIS - M35A3, M35A3C, M36A3

LOCALIZED LUBRICATION POINTS (A THROUGH AP)

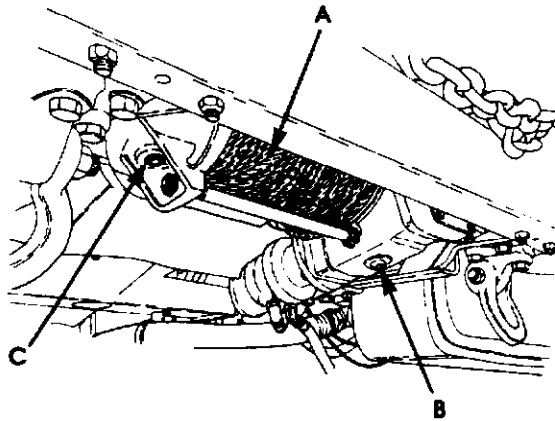

FRONT WINCH

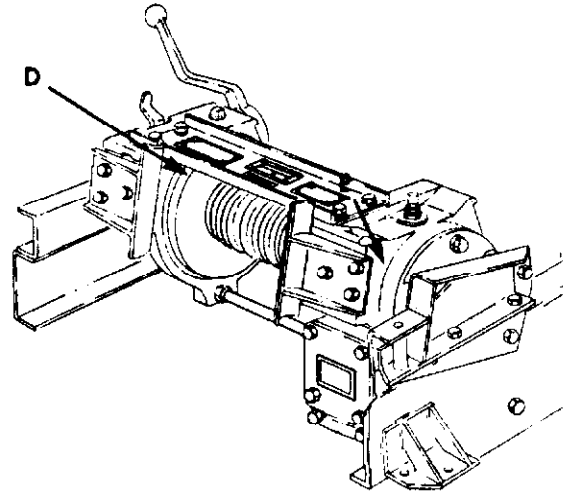

FRONT WINCH

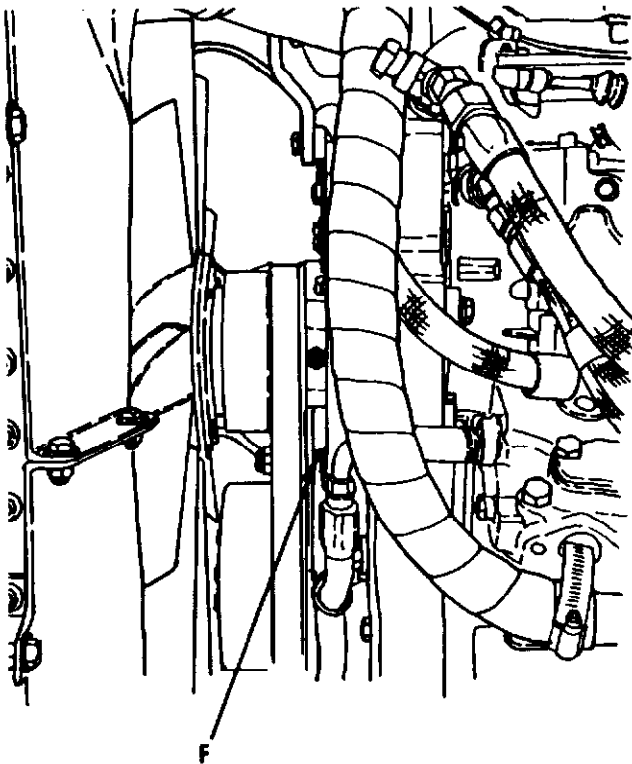

ACCESSORY DRIVE PULLEY

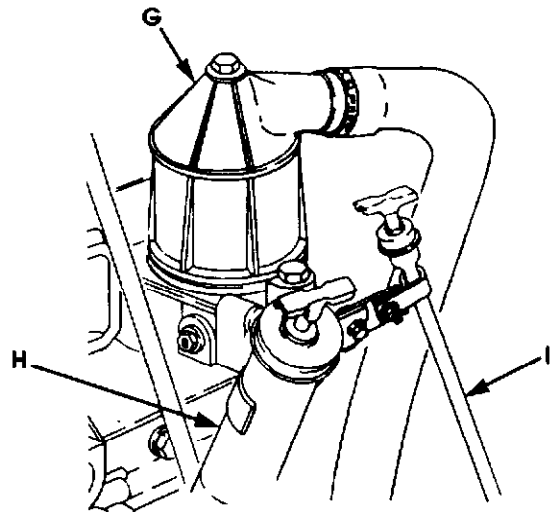

CRANKCASE FILL TUBE, BREATHER, AND DIPSTICK

LOCALIZED LUBRICATION POINTS (A THROUGH AP) (CONTD)

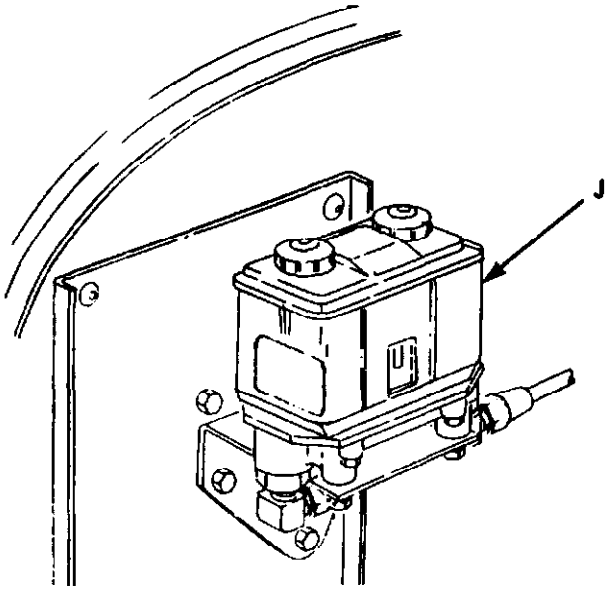

MASTER CYLINDER RESERVOIR

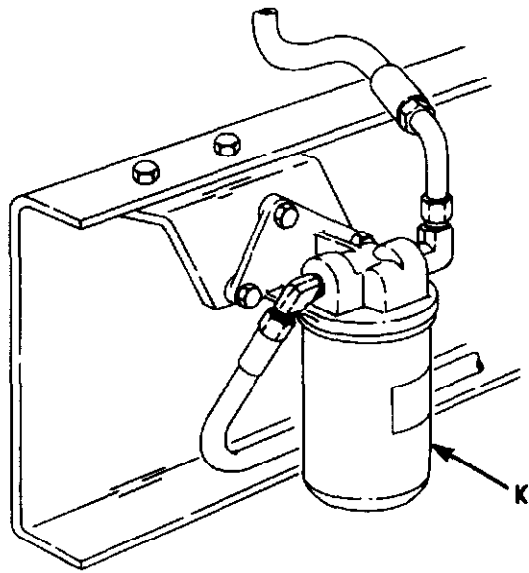

TRANSMISSION EXTERNAL OIL FILTER

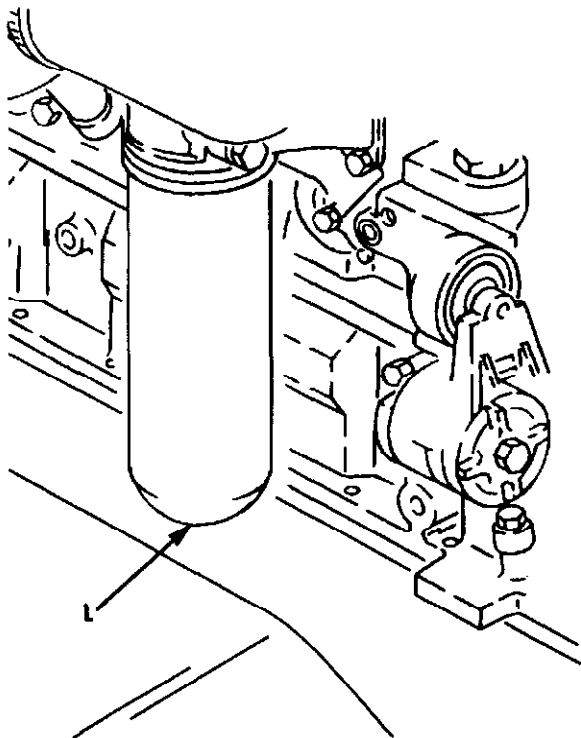

ENGINE OIL FILTER

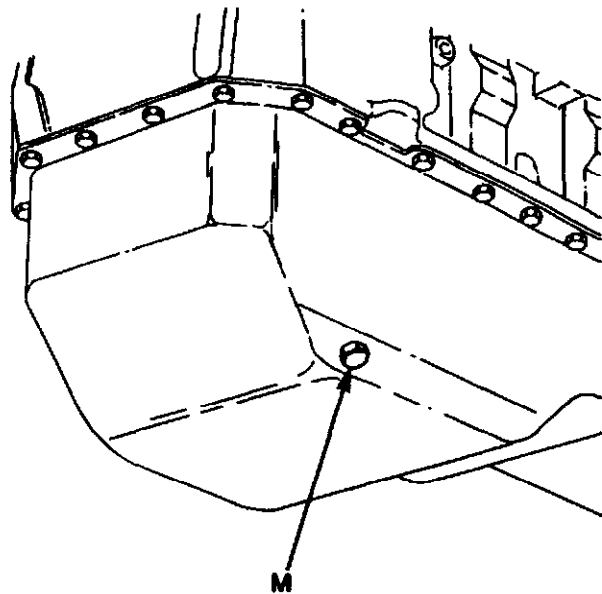

ENGINE CRANKCASE DRAINPLUG

LOCALIZED LUBRICATION POINTS (A THROUGH AP) (CONTD)

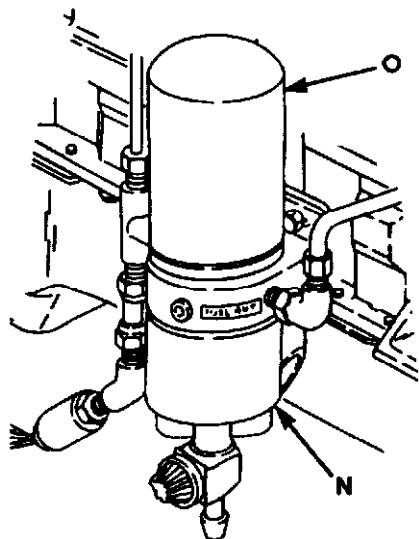

FUEL/WATER SEPARATOR

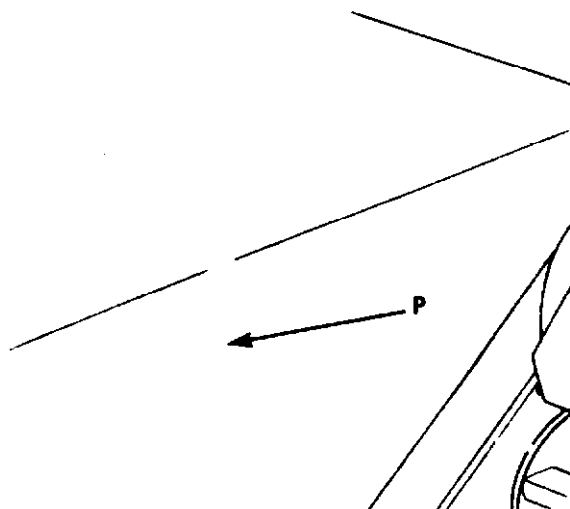

TRANSMISSION FILL TUBE AND DIPSTICK

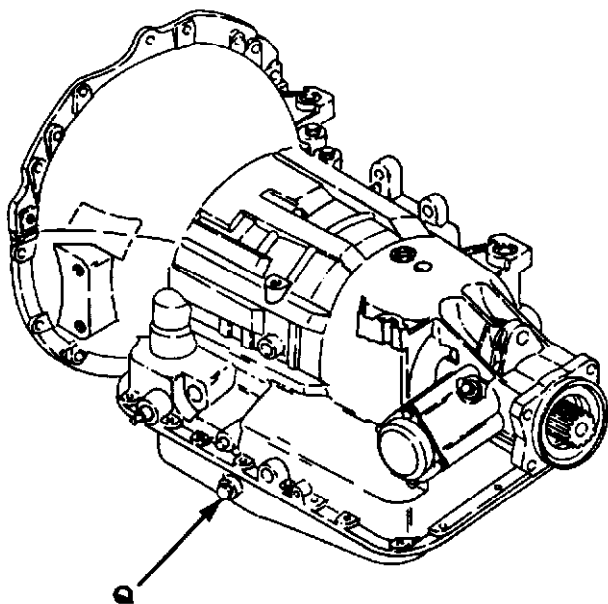

TRANSMISSION DRAINPLUG

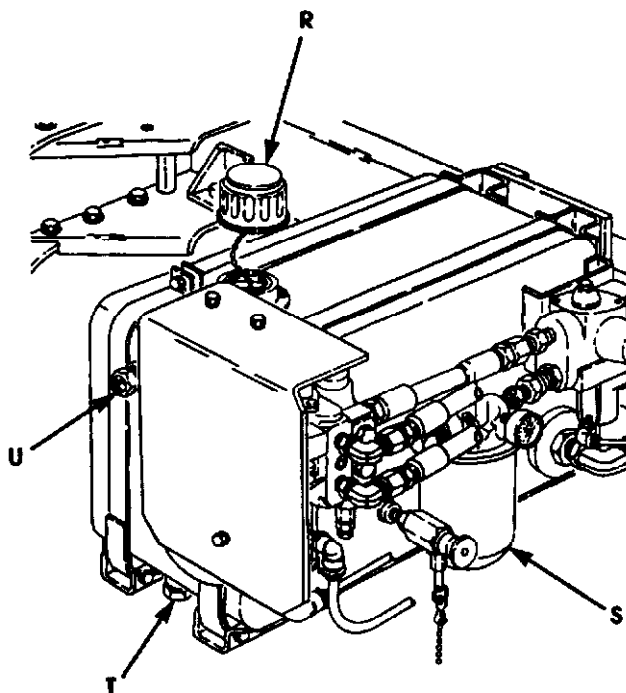

WINCH HYDRAULIC OIL RESERVOIR

LOCALIZED LUBRICATION POINTS (A THROUGH AP) (CONTD)

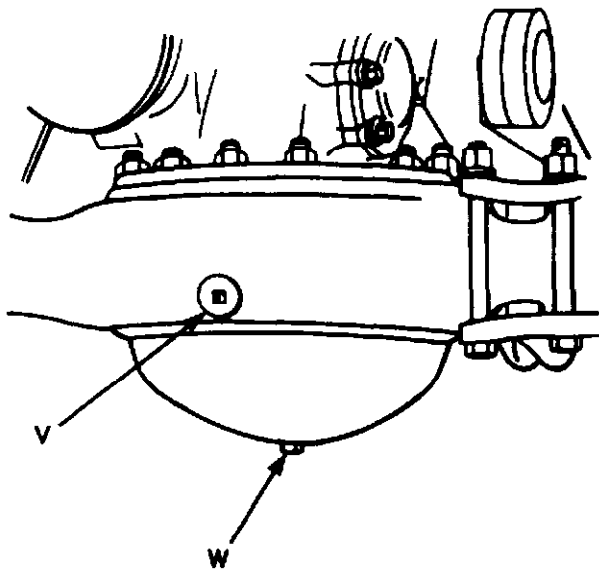

AXLE DIFFERENTIALS

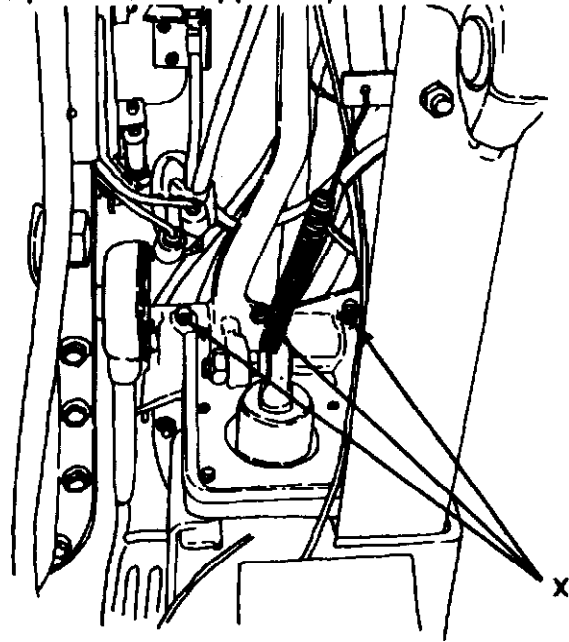

BRAKE PEDAL AND PEDAL SHAFT BRACKET

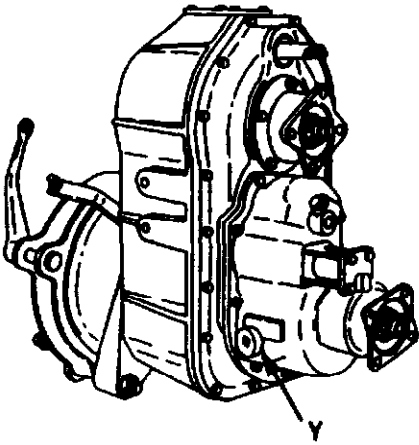

TRANSFER CASE

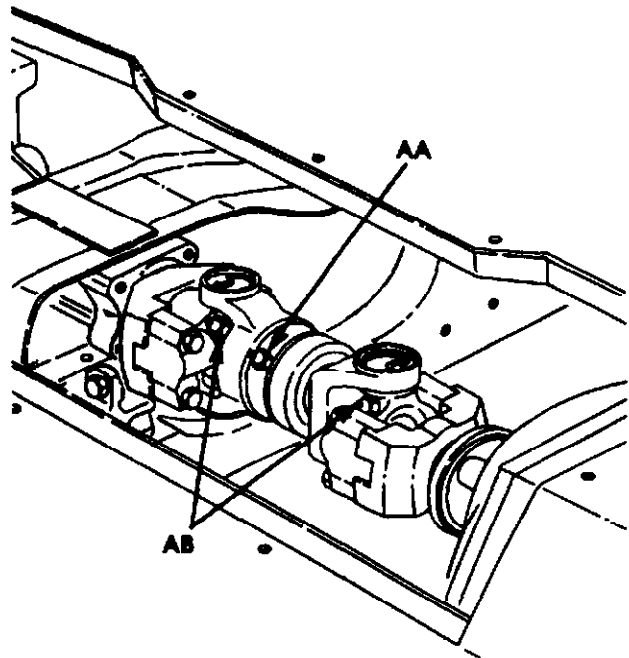
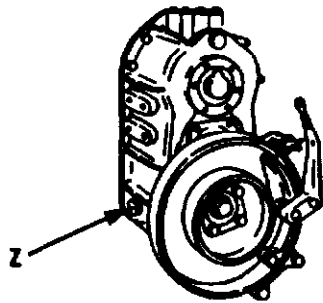

TRANSMISSION-TO-TRANSFER CASE DRIVE
SHAFT UNIVERSAL AND SLIP JOINT

LOCALIZED LUBRICATION POINTS (A THROUGH AP) (CONTD)

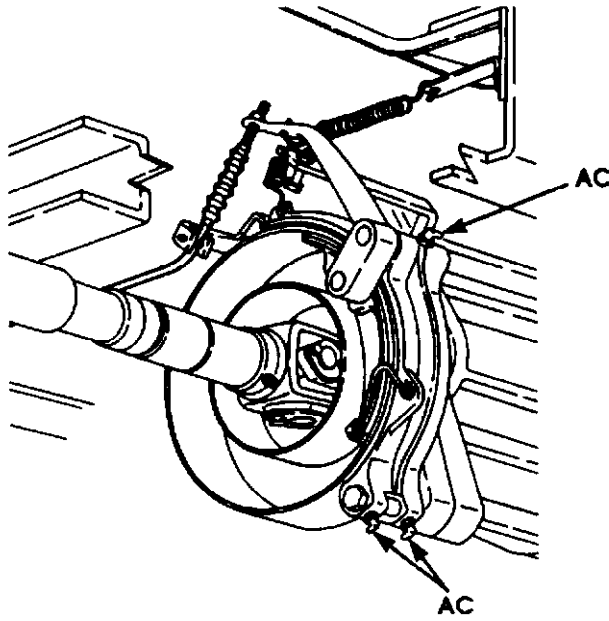

PARKING BRAKE LEVER

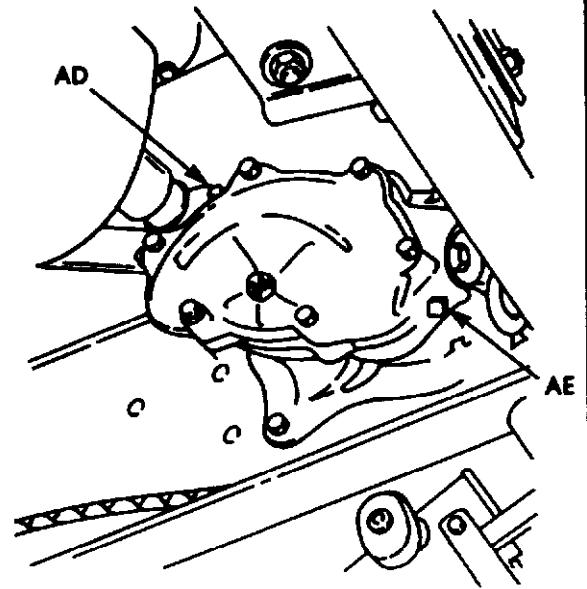

STEERING GEAR

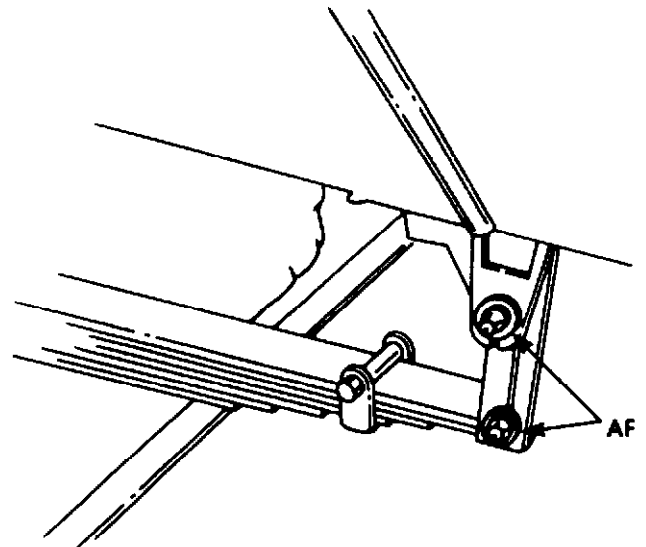
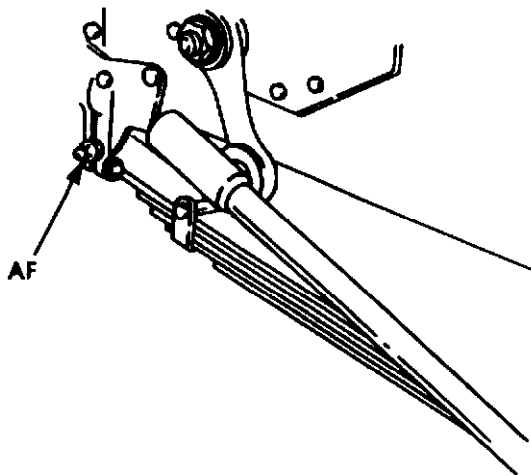

SPRING BOLT FITTINGS

LOCALIZED LUBRICATION POINTS (A THROUGH AP) (CONTD)

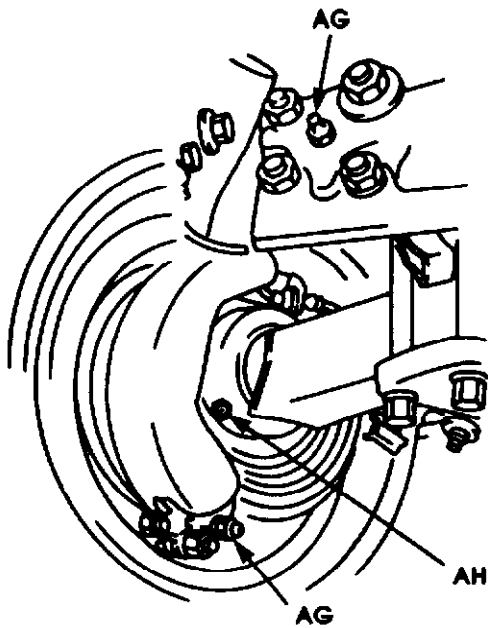

FRONT WHEEL

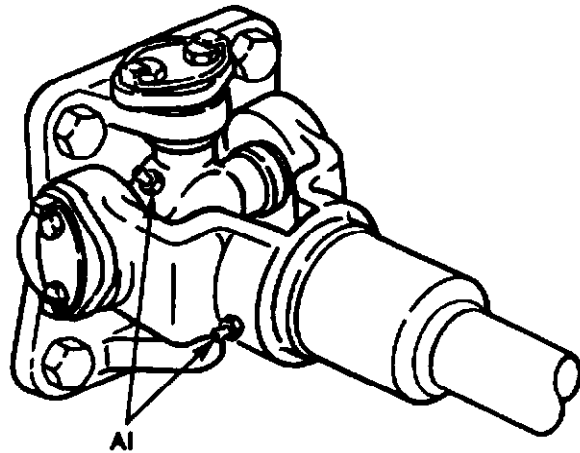

FRONT AXLE DRIVE SHAFT UNIVERSAL

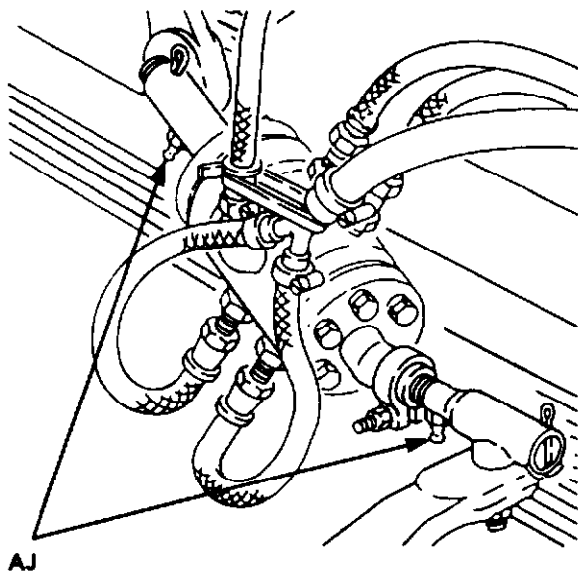

STEERING DRAG LINK

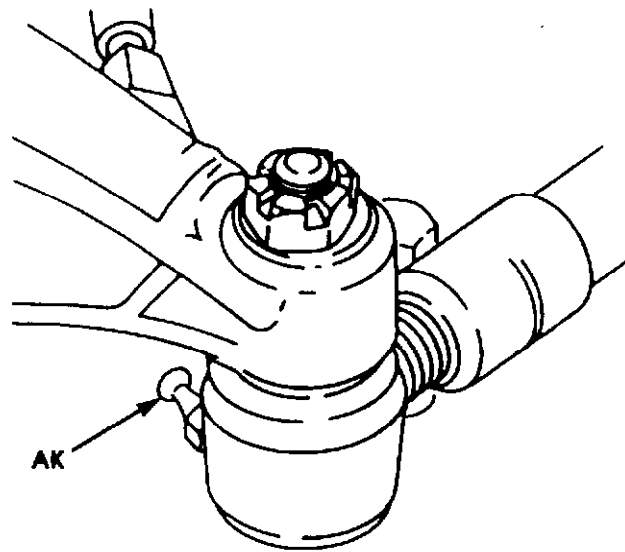

TIE ROD

LOCALIZED LUBRICATION POINTS (A THROUGH AP) (CONTD)

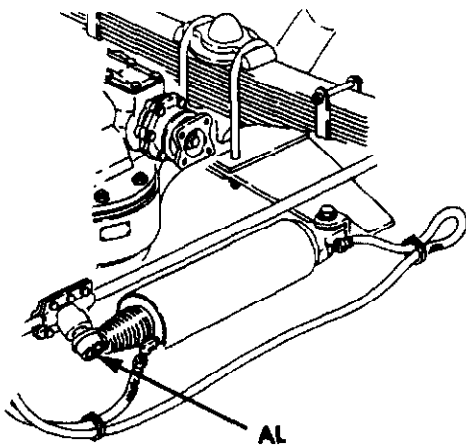

POWER ASSIST CYLINDER

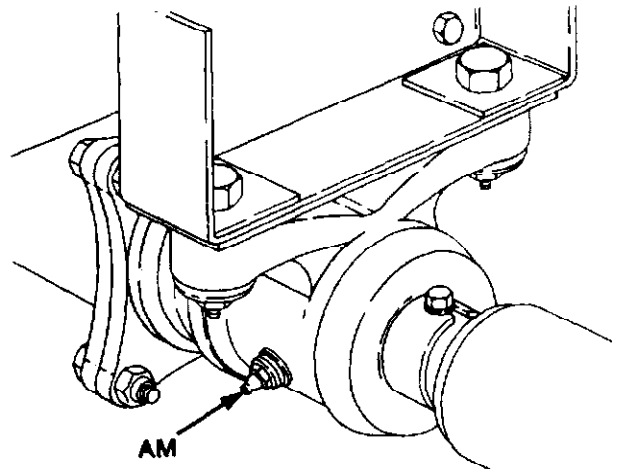

DRIVE SHAFT CENTER BEARING

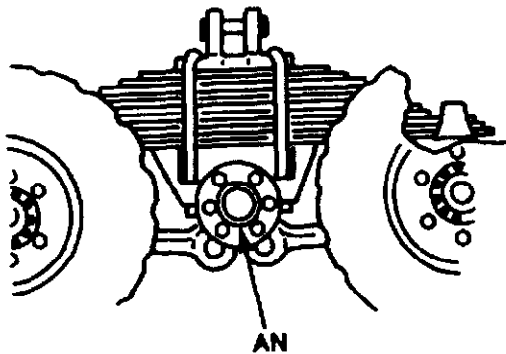

REAR SPRING SEAT BEARING

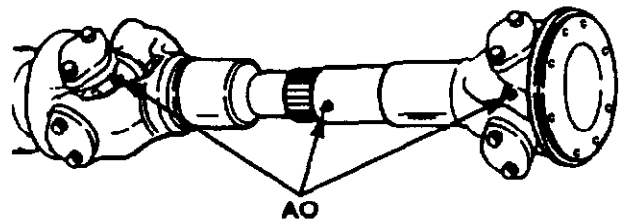

FORWARD-REAR AND REAR-REAR AXLE
DRIVE SHAFT UNIVERSAL

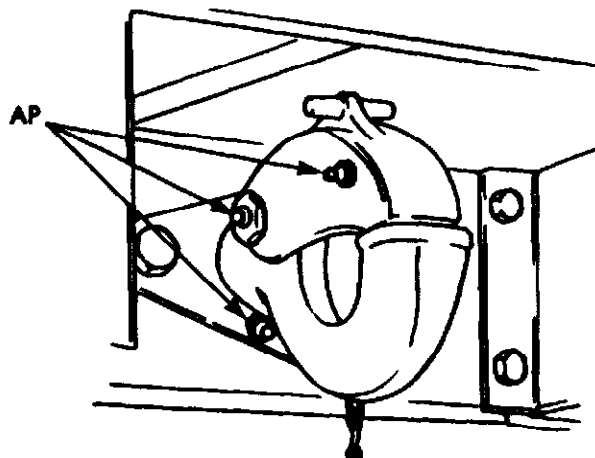

PINTLE

LUBRICATION TABLES

Table III. Lubrication Intervals.

COMPONENT	INTERVAL	REFERENCE
Engine Crankcase	Check oil level daily, before vehicle operation. Oil will be changed only when directed by AOAP laboratory. When AOAP laboratory support is not available, change oil and oil filter element every 6 months or 6,000 mi (9,654 km).	TM 9-2320-386-10 TM 9-2320-386-24
Engine Oil Filter	Replace at each engine oil change.	TM 9-2320-386-24
Fuel Filter/Water Separator	Drain fuel/water separator daily, before and after vehicle operation. Replace fuel filter every 6 months or 6,000 mi (9,654 km).	TM 9-2320-386-10 TM 9-2320-386-24
Transmission	Check oil level weekly or before vehicle operation. Oil will be changed only when directed by AOAP laboratory. When AOAP laboratory support is not available, change oil, internal filter, and external filter every 24 months or 24,000 mi (38,616 km).	TM 9-2320-386-10 TM 9-2320-386-24
Transmission Internal Filters	Replace at each transmission oil change.	TM 9-2320-386-24
Transmission External Oil Filter	Replace at each transmission oil change.	TM 9-2320-386-24
Winch Hydraulic Oil Reservoir	Check oil level weekly or before operations. Change oil every 12 months or 12,000 mi (19,308 km).	TM 9-2320-386-10 TM 9-2320-386-24
Winch Hydraulic Oil Filter	Replace at each winch hydraulic reservoir oil change - 12 months or 12,000 mi (19,308 km).	TM 9-2320-386-24
Winch	Change lubricant only when required by maintenance repair action, or if contaminated. Check oil level semiannually or 3,000 mi (4,827 km).	TM 9-2320-386-24
Master Cylinder Reservoir	Check brake fluid daily, before vehicle operation. Service every 6 months or 1,000 mi (1,609 km).	TM 9-2320-386-24
All Oil Can Points	Service monthly or every 1,000 mi (1,609 km).	
Front and Rear Axles	Check oil level semiannually or every 3,000 mi (4,827 km). Change oil only when required by maintenance repair action, or if contaminated.	TM 9-2320-386-24
Transfer Case	Check level semiannually or every 3,000 mi (4,827 km). Change oil only when required by maintenance repair action, or if contaminated.	TM 9-2320-386-24
Steering Gear	Check level every 1,000 mi (1,609 km). Change lubricant only when required by maintenance repair action, or if contaminated.	
Accessory Drive Pulley	Lubricate fitting every 6,000 mi (9,654 km).	

NOTES

1. INTERVALS

This Lubrication Order (LO) has been revised with the Department of Army program to extend intervals to conserve lubricants. This instruction applies only to vehicles in normal operation. Lubricate more frequently to compensate for abnormal or extreme conditions, such as high or low temperatures, immersion in water, or exposure to sand or dust. Lubricants which have become contaminated will be changed regardless of scheduled intervals. Points requiring lubrication at 3,000 miles (4,827 km) on vehicles not accumulating 3,000 miles (4,827 km) in a six-month period, will be lubricated at time of semiannual (S) preventive maintenance service. Points requiring lubrication at 6,000 miles (9,654 km) in a six-month period, will be lubricated at least once a year. Points requiring lubrication at 12,000 miles (19,308 km) will be lubricated annually. When practicable, lubrication services will be made to coincide with semiannual preventive maintenance service. For this purpose, a 10-percent variation in specified lubrication point mileage is permissible.

2. WINCH CABLE

After each day's operation, clean and oil with new OE/HDO. Semiannually, unwind entire cable, clean, and oil. At semiannual PMCS service, if cable is not generally used, unwind entire cable. Use a brush to clean, and soak with new OE/HDO. Wipe off excess, and coat with CW before rewinding cable on drum.

3. GEARCASES

NOTE

When a safe level of lubricant within a gear housing is indicated at time of scheduled lubrication, the lubricant retaining seal is functional, even though the seal may indicate questionable leakage. Questionable leaks that may indicate a defective seal will be subject to frequent observation as a potential problem area. When seepage or leakage of lubricant adversely affects the proper function of parts within the area; e.g., brakes, the retaining seal is non-functional regardless of lubricant level.

Change gear lubricant only when required by maintenance repair action, or if contaminated by water or other foreign material. Semiannually, check lubricant for proper level and for contamination. Drain only when unit is hot after operation. At axle differentials, transfer case, and front winch, check level within 1/2 in. (12.70 mm) of level plug opening. Level in winch end housing is 6-7/8 in. (174.62 mm) below filler plug. Use the full level plug located on the right side on winch worm housing to check lubrication level.

4. CRANKCASE BREATHER

Check and clean crankcase breather and lines every 6,000 miles (9,654 km) under normal operating conditions.

5. MASTER CYLINDER ASSEMBLY

WARNING

Clean master cylinder reservoir filler cap and surrounding area before removing cap. System contamination can result in injury to personnel or damage to equipment.

Check or refill fluid level. Check oil level daily, before vehicle operation. Use BFS (MIL-B-46176). Oil level must be to full line.

NOTES (Cod)

6. OIL FILTERS

Oil filters shall be serviced/cleaned/changed as applicable when:

- They are known to be contaminated or clogged.
- Service is recommended by AOAP laboratory analysis.
- Prescribed hard-time intervals are reached.

7. CRANKCASE

NOTE

- Submit oil samples as soon as they have been taken.
- AOAP does not do away with seasonal oil changes.
Make oil changes as seasonal temperatures require.

a. Sample oil every 60 days or 1,000 miles (1,609 km). Army Reserve Units will sample oil every 120 days or 1,000 miles (1,609 km). Oil will be changed only when directed by oil analysis laboratory.

To check engine oil level, wait at least one minute after shutting down engine to allow oil to drain into crankcase. Safe operating level is between ADD and FULL on dipstick. Do not overfill.

b. When vehicle or engine is placed in storage other than administrative storage, service the crankcase with grade 30 engine oil conforming to specification MIL-L-21260, Lubricating Oil, internal Combustion Engine, Preservative and Break-In. Note that MIL-L-21260 engine oil is an operational lubricant and may be used until the initial scheduled oil change after reactivation of the vehicle or engine. For administrative storage, engine oil conforming to the specification and grade established in Table II, Fluid Capacities and Lubricant Requirements, should be used.

8. FUEL/WATER SEPARATOR

Drain fuel/water separator daily before vehicle operation. If dirt or water is found in drainage, notify unit maintenance for replacement of fuel filter. Replace fuel filter every 6,000 miles (9,654 kilometers) or six months, whichever occurs first.

9. REAR SPRING SEAT BUSHINGS OR BEARINGS

a. Every 3,000 miles (4,827 km) or semiannually, whichever occurs first, remove bearing cap and tighten bearing adjusting nut in accordance with TM 9-2320-361-20. Install cap loosely, and lubricate bearings by removing pipe plug in bottom of spring seat and installing fitting. Lubricate with GAA grease through fitting until lubricant appears around cap. Remove fitting, and reinstall pipe plug.

b. Every 6,000 miles (9,654 km), or annually, whichever occurs first, remove, clean, and inspect bearings. Reinstall bearings, tighten adjusting nuts and locknuts, and lubricate bearings as described in step a. above.

10. TRANSMISSION

a. Check and fill transmission to proper level weekly.

b. Check oil level of automatic transmission using the following procedure:

(1) Allow engine to idle. Shift transmission to neutral and apply parking brake.

(2) Withdraw dipstick slowly to prevent a false reading. If transmission oil temperature gauge reads 160°F (71°C) or below, level on dipstick should show between marks designated for normal run. If transmission oil temperature is above 160°F (71 °C), allow transmission oil to cool.

NOTES (Contd)**CAUTION**

Do not overfill transmission. Internal transmission component damage will result.

(3) If transmission oil level is low, add oil through filler tube. Return dipstick to filler tube, tighten dipstick handle, and wipe away any spilled oil.

c. When AOAP laboratory support is not available, change oil every 24,000 miles (38,616 km) or 24 months, whichever occurs first.

11. WINCH HYDRAULIC OIL RESERVOIR

Weekly check to ensure oil level is visible in sight glass. If low, remove cap and replenish oil to dot on sight glass. Every 12,000 miles (19,308 km) or 12 months, whichever occurs first, remove drainplug from reservoir and drain oil. Always install drainplug after draining. Refill reservoir to dot on sight glass 39 qt (36.9 L).

12. FRONT WHEEL UNIVERSAL JOINTS AND STEERING KNUCKLE BEARINGS

Every 12,000 miles (19,308 km) or annually, whichever occurs first, remove plug from universal joint housing, fill to level of plug opening, and reinstall plug. Remove lugs on each side of steering knuckle, and fill to level of plug opening through upper and lower steering knuckle bearings. Do not disassemble.

13. WHEEL BEARINGS

Every 6,000 miles (9,654 km) or six months, whichever occurs first, remove, clean, dry, repack, and install wheel bearings.

14. FRONT SPRING SHACKLES**CAUTION**

Wipe fittings clean before servicing to prevent damage to shackle pins and bushings.

Every 3,000 miles (4,827 km) or three months, whichever occurs first, lubricate with GAA until grease appears between shackle pin and bushing at both ends of spring shackle. If shackle pin does not accept GAA, remove pin. Clean and inspect shackle pin and bushing. Replace if necessary.

15. OILCAN POINTS

Every 1,000 miles (1,609 km) or monthly, whichever occurs first, lubricate hinges and latches, transfer case linkage, accelerator cable, accelerator linkage, highbeam selector switch, parking brake lever, and spare tire carrier boom roller with seasonal grade OE/HDO.

16. DO NOT LUBRICATE

Springs, alternator, water pump, or shock absorbers.

Copy of this Lubrication Order will remain with the vehicle at all times. Instructions contained herein are mandatory.

DISTRIBUTION:

To be distributed in accordance with the initial distribution number (ION) 381004, requirements for LO 9-2320-386-12.

By Order of the Secretary of the Army:

Official:

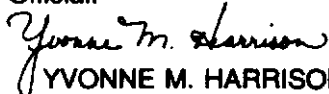

YVONNE M. HARRISON
Administrative Assistant to the
Secretary of the Army
01727

DENNIS J. REIMER
General, United States Army
Chief of Staff

By Order of the Secretary of the Air Force:

Official:

HENRY VICCELLIO, JR.
General, United States Air Force
Commander, Air Force Materiel Command

RONALD R. FOGLEMAN
General, United States Air Force
Chief of Staff